

RoHS Recast Compliant

USB Flash Drive

UV110-UFM1 BiCS3 Product Specifications

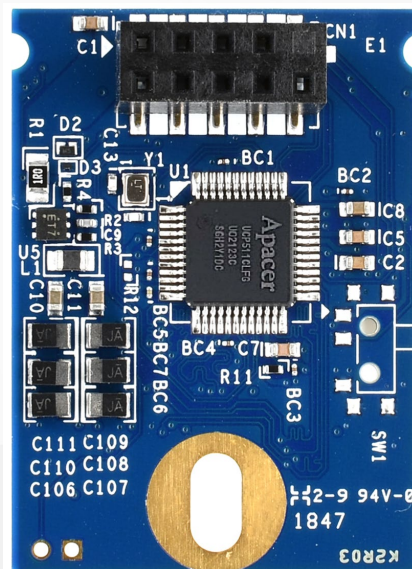

February 10, 2023

Version 1.8



Apacer Technology Inc.

1F, No.32, Zhongcheng Rd., Tucheng Dist., New Taipei City, Taiwan, R.O.C

Tel: +886-2-2267-8000 Fax: +886-2-2267-2261

www.apacer.com

Specifications Overview:

- **USB2.0 High-Speed and USB1.1 Full-Speed Compatible Interface**
- **Capacity**
 - 16, 32, 64, 128 GB
- **Performance¹**
 - Sequential read: Up to 40 MB/sec
 - Sequential write: Up to 33 MB/sec
 - Random read (4K): Up to 1,100 IOPS
 - Random write (4K): Up to 300 IOPS
- **Flash Management**
 - Low-Density Parity-Check (LDPC) Code
 - Flash bad-block management
 - Flash Translation Layer: Page Mapping
 - Global Wear Leveling
 - Power Failure Management
 - S.M.A.R.T.
 - Hyper Cache Technology
 - SMART Read Refresh™
- **Supports Non-Removable Setting**
- **NAND Flash Type: 3D TLC (BiCS3)**
- **MTBF: >3,000,000 hours**
- **Endurance (in drive writes per day: DWPD)**
 - 16 GB: 2.71 DWPD
 - 32 GB: 2.74 DWPD
 - 64 GB: 2.74 DWPD
 - 128 GB: 2.74 DWPD
- **Temperature Range**
 - Operating:
 - Standard: 0°C to 70°C
 - Wide: -40°C to 85°C
 - Storage: -40°C to 100°C
- **OS Support**
 - Windows: Win7/Win10 or later
 - Linux: 2.4.10 or later
- **Power Consumption¹**
 - Operating voltage: 5V (with a certain percentage of tolerance)
 - Active mode (Max.): 110 mA
 - Idle mode: 70 mA
- **Connector**
 - 10-pin (2x5) female header in 2.54mm
- **Dimensions**
 - 36.9(L) x 26.6(W) x 9.7(H), unit: mm
- **RoHS Recast Compliant (2011/65/EU)**

Note:

1. Varies from capacities. The values for performances and power consumptions presented are typical and may vary depending on flash configurations or platform settings. The term idle refers to the standby state of the device.

Table of Contents

1. General Description	3
2. Functional Block	3
3. Pin Assignments.....	4
4. Product Specifications.....	5
4.1 Capacity Specifications	5
4.2 Performance Specifications.....	5
4.3 Environmental Specifications	6
4.4 Mean Time Between Failures (MTBF)	6
4.5 Certification and Compliance.....	6
4.6 Endurance	7
5. Flash Management	8
5.1 Performance-optimized Controller.....	8
5.2 Error Correction/Detection.....	8
5.3 Global Wear Leveling	8
5.4 Flash Translation Layer – Page Mapping.....	8
5.5 Power Failure Management	8
5.6 S.M.A.R.T.	9
5.7 Hyper Cache Technology.....	9
5.8 SMART Read Refresh™	9
6. Electrical Specifications.....	10
6.1 Operating Conditions	10
6.2 Absolute Maximum Rating.....	10
6.3 Power Consumption	10
6.4 AC Characteristics.....	11
7. Mechanical Specifications.....	12
8. Product Ordering Information.....	13
8.1 Product Code Designations.....	13
8.2 Valid Combinations.....	14

1. General Description

Apacer's UV110-UFM1 is a high performance, embedded solid state drive (SSD) designed to replace a conventional IDE hard disk drive. As an embedded flash storage, UV110-UFM1 is compliant with USB 2.0 and backward compliant with USB 1.1 interface.

Utilizing 3D NAND for capacity up to 128GB and providing more power efficiency than 2D NAND, UV110-UFM1 can be plugged into a standard Embedded USB connector commonly found in desktops, portable PC systems and industrial PC systems. Regarding reliability, UV110-UFM1 is implemented with LDPC (Low Density Parity Check) ECC engine to extend SSD endurance and increase data reliability.

In terms of flash management, UV110-UFM1 adopts the latest page mapping file translation layer and comes with various implementations including power saving modes, wear leveling, flash block management, power failure management, S.M.A.R.T., Hyper Cache technology and SMART Read Refresh™.

With cost-effective design, better performance and increased reliability, UV110-UFM1 is well suited for embedded flash storage applications offering new and expanded functionality.

2. Functional Block

UV110-UFM1 contains a controller, embedded firmware, and Flash Media with a female connector. It interfaces with the host system allowing data to be written to and read from the Flash Media.

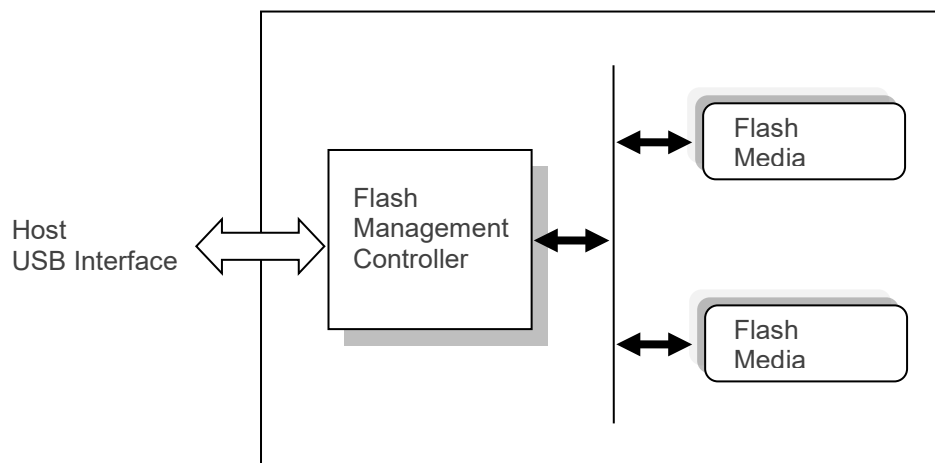

Figure 2-1 Functional Block Diagram

3. Pin Assignments

This chapter provides information on the pin assignments and signal descriptions.

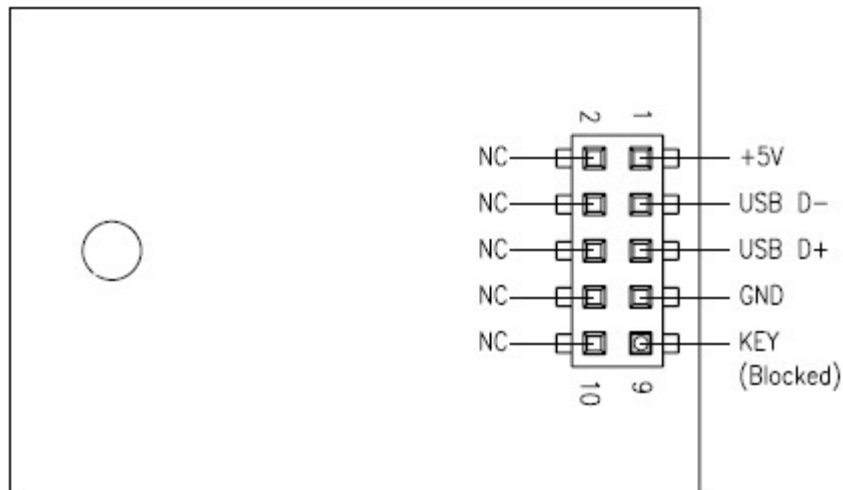

Figure 3-1 Pin Assignments

Table 3-1 Pin Assignment of the 10-Pin Configuration

Pin	Signal	Pin	Signal
1	+5V	2	N.C
3	USB D-	4	N.C
5	USB D+	6	N.C
7	GND	8	N.C
9	Key (Blocked)	10	N.C

4. Product Specifications

4.1 Capacity Specifications

Capacity specifications of UV110-UFM1 are available as shown in Table 4-1.

Table 4-1 Capacity Specifications

Capacity	Total Bytes	Total LBA
16 GB	15,557,361,664	30,385,472
32 GB	31,039,324,160	60,623,680
64 GB	62,018,519,040	121,129,920
128 GB	123,936,440,320	242,063,360

Notes:

- Display of total bytes varies from operating systems.
- 1 GB = 1,000,000,000 bytes; 1 sector = 512 bytes.
- LBA count addressed in the table above indicates total user storage capacity and will remain the same throughout the lifespan of the device. However, the total usable capacity of the SSD is most likely to be less than the total physical capacity because a small portion of the capacity is reserved for device maintenance usages.

4.2 Performance Specifications

Performance of UV110-UFM1 is listed below in Table 4-2.

Table 4-2 Performance Specifications

Capacity \ Performance	16 GB	32 GB	64 GB	128 GB
Sequential Read (MB/s)	40	40	40	40
Sequential Write (MB/s)	16	17	25	33
Random Read IOPS (4K)	1,100	1,100	1,100	1,100
Random Write IOPS (4K)	200	200	300	300

Notes:

- Results may differ from various flash configurations or host system setting, and the above test results are based on the default file structure with FAT 32 file system.
- Sequential read/write is based on CrystalDiskMark 5.2.1 with file size 1,000MB.
- Random read/write is measured using IOMeter with Queue Depth 32.

4.3 Environmental Specifications

Environmental specification of UV110-UFM1 is available as shown in Table 4-3.

Table 4-3 Environmental Specifications

Item	Specifications
Temperature	Operating: 0°C to 70°C (Standard); -40°C to 85°C (Wide)
	Non-operating: -40°C to 100°C
Shock	Operating: 50(G)/11(ms)/half sine (compliant with MIL-STD-202G)
	Non-operating: 1,500(G)/0.5(ms)/half sine (compliant with MIL-STD-883K)
Vibration	Operating: 7.69(Grms), 20~2000(Hz)/random (compliant with MIL-STD-810G)
	Non-operating: 4.02(Grms), 15~2000(Hz)/random (compliant with MIL-STD-810G)
EMC	CE, UKCA, FCC

Note: This Environmental Specification table indicates the conditions for testing the device. Real world usages may affect the results.

4.4 Mean Time Between Failures (MTBF)

Mean Time Between Failures (MTBF) is predicted based on reliability data for the individual components in Apacer’s USB flash drive. Serving as statistical reference, the prediction result for Apacer’s UV110-UFM1 is more than 3,000,000 hours.

Note: The MTBF is predicated and calculated based on “Telcordia Technologies Special Report, SR-332, Issue 3” method.

4.5 Certification and Compliance

UV110-UFM1 complies with the following standards:

- CE
- UKCA
- FCC
- RoHS Recast
- MIL-STD-810G

4.6 Endurance

The endurance of a storage device is predicted by Drive Writes Per Day based on several factors related to usage, such as the amount of data written into the drive, block management conditions, and daily workload for the drive. Thus, key factors, such as Write Amplifications and the number of P/E cycles, can influence the lifespan of the drive.

Table 4-4 Endurance Specifications

Capacity	Drive Writes Per Day
16 GB	2.71
32 GB	2.74
64 GB	2.74
128 GB	2.74

Notes:

- This estimation values are based on sequential write behavior (Apacer EDTestTool, test mode –sequential data pattern -100.00% of disk space with 128K)
- Flash vendor guaranteed 3D NAND TLC P/E cycle: 3K
- WAF may vary from capacity, flash configurations and writing behavior on each platform.
- 1 Terabyte = 1,024GB
- DWPD (Drive Write s Per Day) is calculated based on the number of times that user overwrites the entire capacity of an SSD per day of its lifetime during the warranty period. (3D NAND TLC warranty: 3 years)

5. Flash Management

5.1 Performance-optimized Controller

The heart of UV110-UFM1 is the USB controller, which translates standard USB signals into the data and controls of the flash media. This proprietary USB controller is specifically designed to attain high data throughput from host to flash.

5.2 Error Correction/Detection

UV110-UFM1 implements a hardware ECC scheme, based on the Low Density Parity Check (LDPC). LDPC is a class of linear block error correcting code which has apparent coding gain over BCH code because LDPC code includes both hard decoding and soft decoding algorithms. With the error rate decreasing, LDPC can extend SSD endurance and increase data reliability while reading raw data inside a flash chip.

5.3 Global Wear Leveling

Flash memory can be erased a limited number of times, This number is called the erase cycle limit, or write endurance limit, The erase cycle limit applies to each individual erase block in the flash device.

In a typical application, and especially if a file system is used, specific pages are constantly updated (e.g., the page that contains the FAT, registry, etc.). Without any special handling, these pages would wear out more rapidly than other pages, reducing the lifetime of the entire flash.

To overcome this inherent deficiency, Apacer's UV110-UFM1 uses Global Wear Leveling algorithm. This algorithm ensures that consecutive writes of a specific sector are not written physically to the same page in the flash. This spreads flash media usage evenly across all pages, thereby maximizing flash lifetime.

The Global Wear Leveling mechanism provides write/erase cycles for reliable data storage over an extended period.

5.4 Flash Translation Layer – Page Mapping

Page mapping is an advanced flash management technology whose essence lies in the ability to gather data, distribute the data into flash pages automatically, and then schedule the data to be evenly written. Page-level mapping uses one page as the unit of mapping. The most important characteristic is that each logical page can be mapped to any physical page on the flash memory device. This mapping algorithm allows different sizes of data to be written to a block as if the data is written to a data pool and it does not need to take extra operations to process a write command. Thus, page mapping is adopted to increase random access speed and improve SSD lifespan, reduce block erase frequency, and achieve optimized performance and lifespan.

5.5 Power Failure Management

Power Failure Management plays a crucial role when power supply becomes unstable. Power disruption may occur when users are storing data into the SSD, leading to instability in the drive. However, with Power Failure Management, a firmware protection mechanism will be activated to scan pages and blocks once power is resumed. Valid data will be transferred to new blocks for merging and the mapping table will be rebuilt. Therefore, data reliability can be reinforced, preventing damage to data stored in the NAND Flash.

5.6 S.M.A.R.T.

S.M.A.R.T. is an abbreviation for Self-Monitoring, Analysis and Reporting Technology, a self-monitoring system that provides indicators of drive health as well as potential disk problems. It serves as a warning for users from unscheduled downtime by monitoring and displaying critical drive information. Ideally, this should allow taking proactive actions to prevent drive failure and make use of S.M.A.R.T. information for future product development reference.

Table 5-1 SMART Attribute ID List

ID (Hex)	Attribute Name
162 (0xA2)	Spare Block Count
163 (0xA3)	Maximum Erase Count
164 (0xA4)	Average Erase Count
166 (0xA6)	Total Later Bad Block Count
167 (0xA7)	Protect Mode

5.7 Hyper Cache Technology

Apacer proprietary Hyper Cache technology uses a portion of the available capacity as SLC (1bit-per-cell) NAND flash memory, called Hyper cache mode. When data is written to SSD, the firmware will direct the data to Hyper Cache mode, providing excellent performance to handle various scenarios in industrial use.

5.8 SMART Read Refresh™

Apacer's SMART Read Refresh plays a proactive role in avoiding read disturb errors from occurring to ensure health status of all blocks of NAND flash. Developed for read-intensive applications in particular, SMART Read Refresh is employed to make sure that during read operations, when the read operation threshold is reached, the data is refreshed by re-writing it to a different block for subsequent use.

6. Electrical Specifications

6.1 Operating Conditions

Table 6-1 lists the absolute stress rating for UV110-UFM1.

Caution: Absolute Maximum Stress Ratings – Applied conditions greater than those listed under “Absolute Maximum Stress Ratings” may cause permanent damage to the device. This is a stress rating only and functional operation of the device at these conditions or conditions greater than those defined in the operational sections of this data sheet is not implied. Exposure to absolute maximum stress rating conditions may affect device reliability.

Table 6-1 Absolute Stress Rating

Range	Ambient Temperature	Voltage
Standard Temperature	0°C to 70°C	4.5-5.5V
Wide Temperature	-40°C to 85°C	

6.2 Absolute Maximum Rating

Table 6-2 lists the absolute maximum power ratings for UV110-UFM1.

Table 6-2 Absolute maximum power pin stress ratings

Parameter	Symbol	Min	Max	Unit
Power Supply Input	VDD- VSS	-0.3	5.5	V
Voltage on any pin except VDD with respect to GND	VIN	-ss - 0.3	VDD +0.3	V

6.3 Power Consumption

Table 6-3 lists the power consumption for UV110-UFM1.

Table 6-3 Power Consumption (Unit: mA)

Mode \ Capacity	Capacity			
	16 GB	32 GB	64 GB	128 GB
Active (Max.)	90	95	110	110
Idle	70	70	70	70

Notes:

- All values are typical and may vary depending on flash configurations or host system settings.
- Power consumption is measured using CrystalDiskMark 5.2.1.

6.4 AC Characteristics

Table 6-4 AC Characteristics Full Speed

Parameter	Symbol	Min	Typ	Max	Unit
Rise Time	T_{FR}	4	—	20	ns
Fall Time	T_{FF}	4	—	20	ns
Differential Rise and Fall Time Matching	T_{FRFM}	90		111.11	%
Driver Output Resistance	Z_{DRV}	28	—	44	Ω

Table 6-5 AC Characteristics High Speed

Parameter	Symbol	Min	Typ	Max	Unit
Rise Time (10%~90%)	T_{HSR}	500	—	—	ps
Fall Time (10%~90%)	T_{HSF}	500	—	—	ps
Driver Output Resistance	Z_{HSDRV}	40.5	—	49.5	Ω

8. Product Ordering Information

8.1 Product Code Designations

Apacer's UV110-UFM1 is available in different configurations and densities. See the chart below for a comprehensive list of options for the UV110-UFM1 series devices.

Code	1	2	3	4	5	6	7	8	9	10	11	12	13	14	15	16
	A	P	2	.	1	1	2	X	X	N	.	X	X	X	1	5

Code 1-3 (Product Line & Form Factor)	USB+UFM1
Code 5-6 (Model/Solution)	UV110-UFM1
Code 7-8 (Product Capacity)	2E: 16GB 2F: 32GB 2G: 64GB 2H: 128GB
Code 9 (Flash Type & Product Temp)	G: TLC standard temperature H: TLC wide temperature
Code 10 (Product Spec)	UV110-UFM1 (90D Type C) without write protect switch
Code 12-14 (Version Number)	Random numbers generated by system
Code 15-16 (Firmware Version)	UFPA312A

8.2 Valid Combinations

The following table lists the available models of the UV110-UFM1 series which are in mass production or will be in mass production. Consult your Apacer sales representative to confirm availability of valid combinations and to determine availability of new combinations.

Capacity	Standard Temperature	Wide Temperature
16GB	AP2.112EGN.00115	N/A
32GB	AP2.112FGN.00115	AP2.112FHN.00315
64GB	AP2.112GGN.00115	AP2.112GHN.00115
128GB	AP2.112HGN.00115	AP2.112HHN.00415

Revision History

Revision	Description	Date
1.0	Initial release	7/21/2020
1.1	Updated 1. General Descriptions by adding a description regarding USB2.0 compliance and USB1.1 compatibility	8/11/2020
1.2	- Added Power Failure Management to Flash Management on Specifications Overview page - Added 5.5 Power Failure Management	11/6/2020
1.3	Updated 8.1 Product Code Designations by changing the description of code 5-6 to UV110-UFM1	3/19/2021
1.4	Updated wide-temp 32GB and 128GB valid combinations at 8.2.1 Without Write Protect	9/5/2022
1.5	Updated product photo on the cover page	9/6/2022
1.6	- Updated Endurance on Specifications Overview page and Table 4-4 - Added Table 5-1	9/20/2022
1.7	- Updated Table 4-3 by changing compliance standard for non-operating shock specification and adding UKCA - Added UKCA to 4.5 Certification and Compliance	12/12/2022
1.8	Removed write protect switch support	2/10/2023

Global Presence

Taiwan (Headquarters)

Apacer Technology Inc.

1F., No.32, Zhongcheng Rd., Tucheng Dist.,
New Taipei City 236, Taiwan R.O.C.
Tel: 886-2-2267-8000
Fax: 886-2-2267-2261
amtsales@apacer.com

U.S.A.

Apacer Memory America, Inc.

46732 Lakeview Blvd., Fremont, CA 94538
Tel: 1-408-518-8699
Fax: 1-510-249-9551
sa@apacerus.com

Japan

Apacer Technology Corp.

6F, Daiyontamachi Bldg., 2-17-12, Shibaura, Minato-Ku,
Tokyo, 108-0023, Japan
Tel: 81-3-5419-2668
Fax: 81-3-5419-0018
jpservices@apacer.com

Europe

Apacer Technology B.V.

Science Park Eindhoven 5051 5692 EB Son,
The Netherlands
Tel: 31-40-267-0000
Fax: 31-40-290-0686
sales@apacer.nl

China

Apacer Electronic (Shanghai) Co., Ltd

Room D, 22/FL, No.2, Lane 600, JieyunPlaza,
Tianshan RD, Shanghai, 200051, China
Tel: 86-21-6228-9939
Fax: 86-21-6228-9936
sales@apacer.com.cn

India

Apacer Technologies Pvt Ltd,

1874, South End C Cross, 9th Block Jayanagar,
Bangalore-560069, India
Tel: 91-80-4152-9061/62
Fax: 91-80-4170-0215
sales_india@apacer.com