

RoHS Recast Compliant

USB Flash Drive

Industrial UH110-UFM3 BiCS5 Product Specifications



September 4, 2023

Version 1.1



Apacer Technology Inc.

1F, No.32, Zhongcheng Rd., Tucheng Dist., New Taipei City, Taiwan, R.O.C

Tel: +886-2-2267-8000 Fax: +886-2-2267-2261

www.apacer.com

Specifications Overview:

- **USB2.0 High-Speed and USB1.1 Full-Speed Compatible Interface**
- **Capacity**
 - 32, 64 GB
- **Performance¹**
 - Sequential read: Up to 37 MB/sec
 - Sequential write: Up to 32 MB/sec
 - Random read (4K): Up to 1,200 IOPS
 - Random write (4K): Up to 400 IOPS
- **Flash Management**
 - Low-Density Parity-Check (LDPC) Code
 - Flash bad-block management
 - Flash Translation Layer: Page Mapping
 - Global Wear Leveling
 - Power Failure Management
 - S.M.A.R.T.
 - SLC-liteX
 - SMART Read Refresh™
- **Support Non-Removable Setting**
- **NAND Flash Type: 3D TLC (BiCS5)**
- **Firmware Version: SLC-liteX**
- **MTBF: >3,000,000 hours**
- **Endurance (in drive writes per day : DWPD)**
 - 32 GB: 21.92 DWPD
 - 64 GB: 21.7 DWPD
- **Temperature Range**
 - Operating:
 - Standard: 0°C to 70°C
 - Wide: -40°C to 85°C
 - Storage: -55°C to 100°C
- **Support Boot-up Function for OS**
 - Linux: 4.15
- **Power Consumption¹**
 - Operating voltage: 5V (with a certain percentage of tolerance)
 - Active mode (Max.): 95 mA
 - Idle mode: 75 mA
- **Connector**
 - 10-pin (2x5) female header in 2.54mm
- **Form Factor**
 - **Without Housing**
 - Dimensions: 32.50(L) x 24.00(W) x 5.00(H), unit: mm
 - Net weight: 3.98g ± 5%
 - **With Housing**
 - Dimensions: 35.70(L) x 28.10(W) x 7.20(H), unit: mm
 - Net weight: 6.97g ± 5%
- **Write Protect Switch (optional)**
- **RoHS Recast Compliant (2011/65/EU)**

Note:

1. Varies from capacities. The values for performances and power consumptions presented are typical and may vary depending on flash configurations or platform settings. The term idle refers to the standby state of the device.

Table of Contents

1. General Description	4
2. Functional Block	4
3. Pin Assignments.....	5
3.1 Without Housing	5
3.2 With Housing	5
4. Product Specifications.....	6
4.1 Capacity Specifications	6
4.2 Performance Specifications.....	6
4.3 Environmental Specifications	6
4.4 Mean Time Between Failures (MTBF)	7
4.5 Certification and Compliance.....	7
4.6 Endurance	7
5. Flash Management	8
5.1 Performance-optimized Controller.....	8
5.2 Error Correction/Detection.....	8
5.3 Global Wear Leveling	8
5.4 Flash Translation Layer – Page Mapping.....	8
5.5 Power Failure Management	8
5.6 S.M.A.R.T.	9
5.7 SLC-liteX.....	9
5.8 SMART Read Refresh™	9
6. Electrical Specifications.....	10
6.1 Operating Conditions	10
6.2 Absolute Maximum Rating.....	10
6.3 Power Consumption	10
6.4 AC Characteristics.....	11
7. Mechanical Specifications.....	12
7.1 Without Housing	12
7.1.1 Without Write Protect Switch	12
7.1.2 With Write Protect Switch	13
7.2 With Housing	13

7.3 Write Protect Switch (optional)	14
7.4 Installation Requirements	15
7.4.1 Without Housing	15
7.4.2 With Housing.....	15
8. Product Ordering Information.....	16
8.1 Product Code Designations.....	16
8.2 Valid Combinations.....	17
8.2.1 Without Housing	17
8.2.2 With Housing.....	17

1. General Description

Apacer's UH110-UFM3 is a high performance, embedded solid state drive (SSD) designed to replace a conventional IDE hard disk drive. As an embedded flash storage, UH110-UFM3 is compliant with USB2.0 and backward compliant with USB1.1.

Utilizing 3D NAND for capacity up to 64GB and providing more power efficiency than 2D NAND, UH110-UFM3 can be plugged into a standard Embedded USB connector commonly found in desktops, portable PC systems and industrial PC systems. Regarding reliability, UH110-UFM3 is not only implemented with LDPC (Low Density Parity Check) ECC engine to extend SSD endurance and increase data reliability, but also equipped with SLC-liteX technology to offer higher number of P/E cycles up to 30,000 times.

In terms of flash management, UH110-UFM3 adopts the latest page mapping file translation layer and comes with various implementations including flash block management, wear leveling, power failure management, S.M.A.R.T. power saving modes, and SMART Read Refresh.

UH110-UFM3 is well suited for embedded flash storage applications offering new and expanded functionality as well as more cost-effective designs, better performance and increased reliability.

2. Functional Block

UH110-UFM3 contains a controller, embedded firmware, and Flash Media with a female connector. It interfaces with the host system allowing data to be written to and read from the Flash Media.

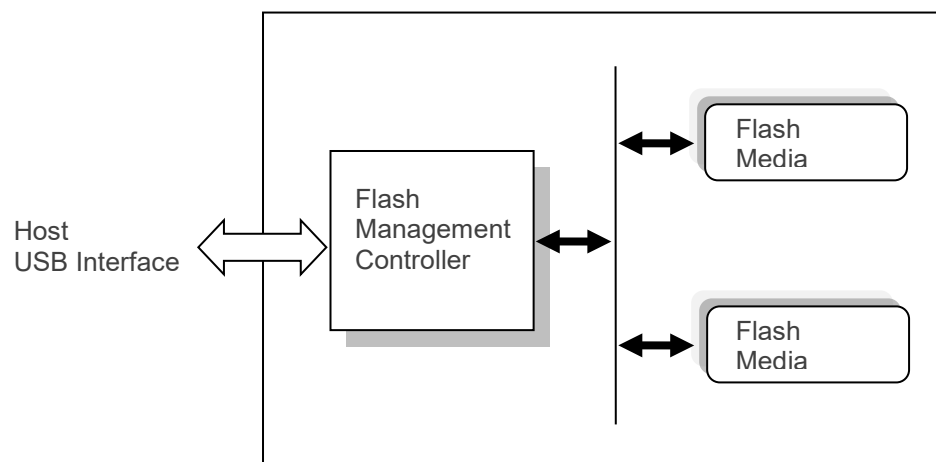

Figure 2-1 Functional Block Diagram

3. Pin Assignments

This chapter provides information on the pin assignments and signal descriptions.

3.1 Without Housing

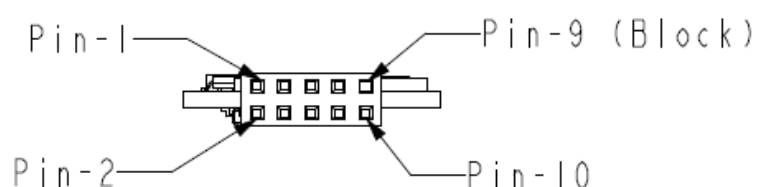

Figure 3-1 Pin Assignments without Housing

Table 3-1 Pin Assignment of the 10-Pin Configuration

Pin	Signal	Pin	Signal
1	+5V	2	N.C
3	USB D-	4	N.C
5	USB D+	6	N.C
7	GND	8	N.C
9	Key (Block)	10	N.C

3.2 With Housing

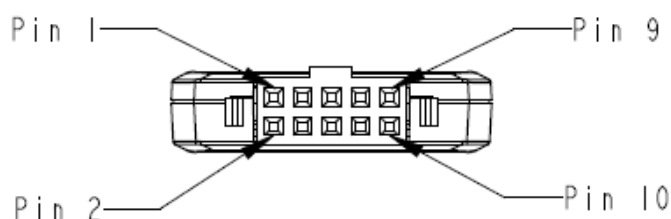

Figure 3-2 Pin Assignments with Housing

Table 3-2 Pin Assignment of the 10-Pin Configuration

Pin	Signal	Pin	Signal
1	+5V	2	N.C.
3	USB D-	4	N.C.
5	USB D+	6	N.C.
7	GND	8	N.C.
9	N.C.	10	N.C.

4. Product Specifications

4.1 Capacity Specifications

UH110-UFM3 is available as shown in Table 4-1.

Table 4-1 Capacity Specifications

Capacity	Total Bytes	Total LBA
32 GB	31,057,674,240	60,659,520
64 GB	62,032,674,816	121,157,568

Note: The number of total bytes may vary depending on the file system in use.

4.2 Performance Specifications

Performance of UH110-UFM3 is listed below in Table 4-2.

Table 4-2 Performance Specifications

Performance	Capacity	32 GB	64 GB
	Sequential Read (MB/s)		37
Sequential Write (MB/s)		20	32
4K Random Read (IOPS)		1,200	1,200
4K Random Write (IOPS)		300	400

Notes:

- Results may differ from various flash configurations or host system setting, and the above test results are based on the default file structure with FAT 32 file system.
- Sequential read/write is based on CrystalDiskMark 8.0.4 with file size 1,000MB.
- Random read/write is measured using IOMeter with Queue Depth 32.

4.3 Environmental Specifications

Environmental specification of UH110-UFM3 is available as shown in Table 4-3.

Table 4-3 Environmental Specifications

Parameter	Type	Specifications
Temperature	Operating	0°C to 70°C (Standard); -40°C to 85°C (Wide)
	Non-operating	-55°C to 100°C
Vibration	Operating	7.69 GRMS, 20~2000 Hz/random (compliant with MIL-STD-810G)
	Non-operating	4.02 GRMS, 15~2000 Hz/random (compliant with MIL-STD-810G)
Shock	Operating	Acceleration, 50(G)/11(ms)/half sine (compliant with MIL-STD-202G)
	Non-operating	Acceleration, 1500(G)/0.5(ms)/half sine (compliant with MIL-STD-883K)

Note: This Environmental Specification table indicates the conditions for testing the device. Real world usages may affect the results.

4.4 Mean Time Between Failures (MTBF)

Mean Time Between Failures (MTBF) is predicted based on reliability data for the individual components in Apacer’s USB flash drive. Serving as statistical reference, the prediction result for Apacer’s UH110-UFM3 is more than 3,000,000 hours.

Note: The MTBF is predicated and calculated based on “Telcordia Technologies Special Report, SR-332, Issue 3” method.

4.5 Certification and Compliance

UH110-UFM3 complies with the following standards:

- CE
- UKCA
- FCC
- RoHS Recast
- MIL-STD-810G

4.6 Endurance

The endurance of a storage device is predicted by Drive Writes Per Day based on several factors related to usage, such as the amount of data written into the drive, block management conditions, and daily workload for the drive. Thus, key factors, such as Write Amplifications and the number of P/E cycles, can influence the lifespan of the drive.

Table 4-4 Endurance Specifications

Capacity	Drive Writes Per Day
32 GB	21.92
64 GB	21.7

Notes:

- This estimation values are based on sequential write behavior (Apacer EDTestTool, test mode –sequential data pattern -100.00% of disk space with 128K)
- Flash vendor guaranteed SLC-liteX P/E cycle: 30K
- WAF may vary from capacity, flash configurations and writing behavior on each platform.
- 1 Terabyte = 1,024GB
- DWPD (Drive Write Per Day) is calculated based on the number of times that user overwrites the entire capacity of an SSD per day of its lifetime during the warranty period. (SLC-liteX warranty: 5 years)

5. Flash Management

5.1 Performance-optimized Controller

The heart of UH110-UFM3 is the USB controller, which translates standard USB signals into the data and controls of the flash media. This proprietary USB controller is specifically designed to attain high data throughput from host to flash.

5.2 Error Correction/Detection

UH110-UFM3 implements a hardware ECC scheme, based on the Low Density Parity Check (LDPC). LDPC is a class of linear block error correcting code which has apparent coding gain over BCH code because LDPC code includes both hard decoding and soft decoding algorithms. With the error rate decreasing, LDPC can extend SSD endurance and increase data reliability while reading raw data inside a flash chip.

5.3 Global Wear Leveling

Flash memory can be erased a limited number of times, This number is called the erase cycle limit, or write endurance limit, The erase cycle limit applies to each individual erase block in the flash device.

In a typical application, and especially if a file system is used, specific pages are constantly updated (e.g., the page that contains the FAT, registry, etc.). Without any special handling, these pages would wear out more rapidly than other pages, reducing the lifetime of the entire flash.

To overcome this inherent deficiency, Apacer's UH110-UFM3 uses Global Wear Leveling algorithm. This algorithm ensures that consecutive writes of a specific sector are not written physically to the same page in the flash. This spreads flash media usage evenly across all pages, thereby maximizing flash lifetime.

The Global Wear Leveling mechanism provides write/erase cycles for reliable data storage over an extended period.

5.4 Flash Translation Layer – Page Mapping

Page mapping is an advanced flash management technology whose essence lies in the ability to gather data, distribute the data into flash pages automatically, and then schedule the data to be evenly written. Page-level mapping uses one page as the unit of mapping. The most important characteristic is that each logical page can be mapped to any physical page on the flash memory device. This mapping algorithm allows different sizes of data to be written to a block as if the data is written to a data pool and it does not need to take extra operations to process a write command. Thus, page mapping is adopted to increase random access speed and improve SSD lifespan, reduce block erase frequency, and achieve optimized performance and lifespan.

5.5 Power Failure Management

Power Failure Management plays a crucial role when power supply becomes unstable. Power disruption may occur when users are storing data into the SSD, leading to instability in the drive. However, with Power Failure Management, a firmware protection mechanism will be activated to scan pages and blocks once power is resumed. Valid data will be transferred to new blocks for merging and the mapping table will be rebuilt. Therefore, data reliability can be reinforced, preventing damage to data stored in the NAND Flash.

5.6 S.M.A.R.T.

S.M.A.R.T. is an abbreviation for Self-Monitoring, Analysis and Reporting Technology, a self-monitoring system that provides indicators of drive health as well as potential disk problems. It serves as a warning for users from unscheduled downtime by monitoring and displaying critical drive information. Ideally, this should allow taking proactive actions to prevent drive failure and make use of S.M.A.R.T. information for future product development reference.

Table 5-1 SMART Attribute ID List

ID (Hex)	Attribute Name
162 (0xA2)	Spare Block Count
163 (0xA3)	Maximum Erase Count
164 (0xA4)	Average Erase Count
166 (0xA6)	Total Later Bad Block Count
167 (0xA7)	Protect Mode

5.7 SLC-liteX

SLC-liteX is based on 3D NAND technology. The firmware is carefully tweaked by our engineering team so as to offer the greatest number of P/E cycles in this format – 30,000, which is 10 times more than MLC or industrial 3D TLC. Cost-savings can be realized for buyers who want to get the longest lifespans possible.

5.8 SMART Read Refresh™

Apacer's SMART Read Refresh plays a proactive role in avoiding read disturb errors from occurring to ensure health status of all blocks of NAND flash. Developed for read-intensive applications in particular, SMART Read Refresh is employed to make sure that during read operations, when the read operation threshold is reached, the data is refreshed by re-writing it to a different block for subsequent use.

6. Electrical Specifications

6.1 Operating Conditions

Caution: Absolute Maximum Stress Ratings – Applied conditions greater than those listed under “Absolute Maximum Stress Ratings” may cause permanent damage to the device. This is a stress rating only and functional operation of the device at these conditions or conditions greater than those defined in the operational sections of this data sheet is not implied. Exposure to absolute maximum stress rating conditions may affect device reliability.

Table 6-1 Operating Range

Range	Ambient Temperature	Voltage
Standard Temperature	0°C to 70°C	4.5-5.5V
Wide Temperature	-40°C to 85°C	

6.2 Absolute Maximum Rating

Table 6-2 lists the absolute maximum power ratings for UH110-UFM3.

Table 6-2 Absolute maximum power pin stress ratings

Parameter	Symbol	Min	Max	Unit
Power Supply Input	VDD- VSS	-0.3	5.5	V
Voltage on any pin except VDD with respect to GND	VIN	-ss - 0.3	VDD +0.3	V

6.3 Power Consumption

Table 6-3 lists the power consumption for UH110-UFM3.

Table 6-3 Power Consumption

Mode	Capacity		32 GB	64 GB
	Unit			
Active (Max.)	mA		95	95
Idle			75	75

Notes:

- All values are typical and may vary depending on flash configurations or host system settings.
- Power consumption is measured using CrystalDiskMark 8.0.4 with file size 1,000MB.

6.4 AC Characteristics

Table 6-4 AC Characteristics Full Speed

Parameter	Symbol	Min	Typ	Max	Unit
Rise Time	T_{FR}	4	—	20	ns
Fall Time	T_{FF}	4	—	20	ns
Differential Rise and Fall Time Matching	T_{FRFM}	90		111.11	%
Driver Output Resistance	Z_{DRV}	28	—	44	Ω

Table 6-5 AC Characteristics High Speed

Parameter	Symbol	Min	Typ	Max	Unit
Rise Time (10%~90%)	T_{HSR}	500	—	—	ps
Fall Time (10%~90%)	T_{HSF}	500	—	—	ps
Driver Output Resistance	Z_{HSDRV}	40.5	—	49.5	Ω

7. Mechanical Specifications

7.1 Without Housing

Table 7-1 Physical Information without Housing

Parameter	Unit	32 GB	64 GB
Length	mm	32.50 ± 0.50	
Width		24.00 ± 0.15	
Height		5.00 ± 0.20	
Weight	g ± 5%	3.92	3.98

7.1.1 Without Write Protect Switch

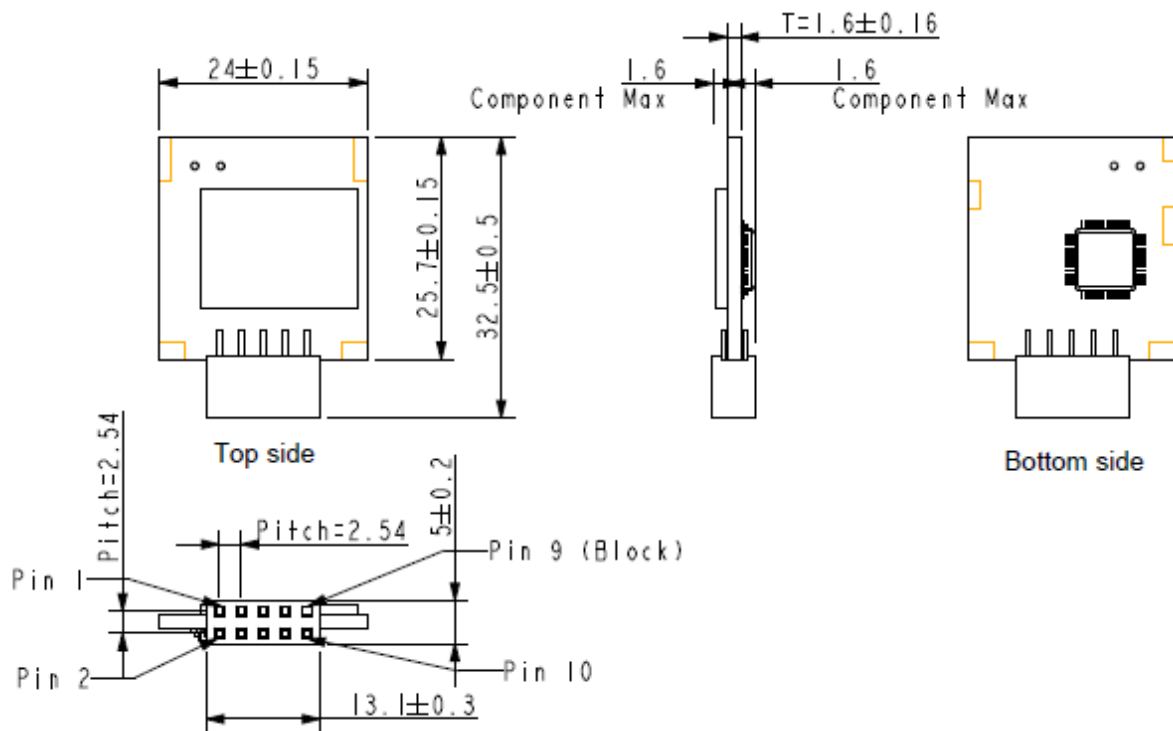

Figure 7-1 Physical Dimensions without Write Protect Switch

7.1.2 With Write Protect Switch

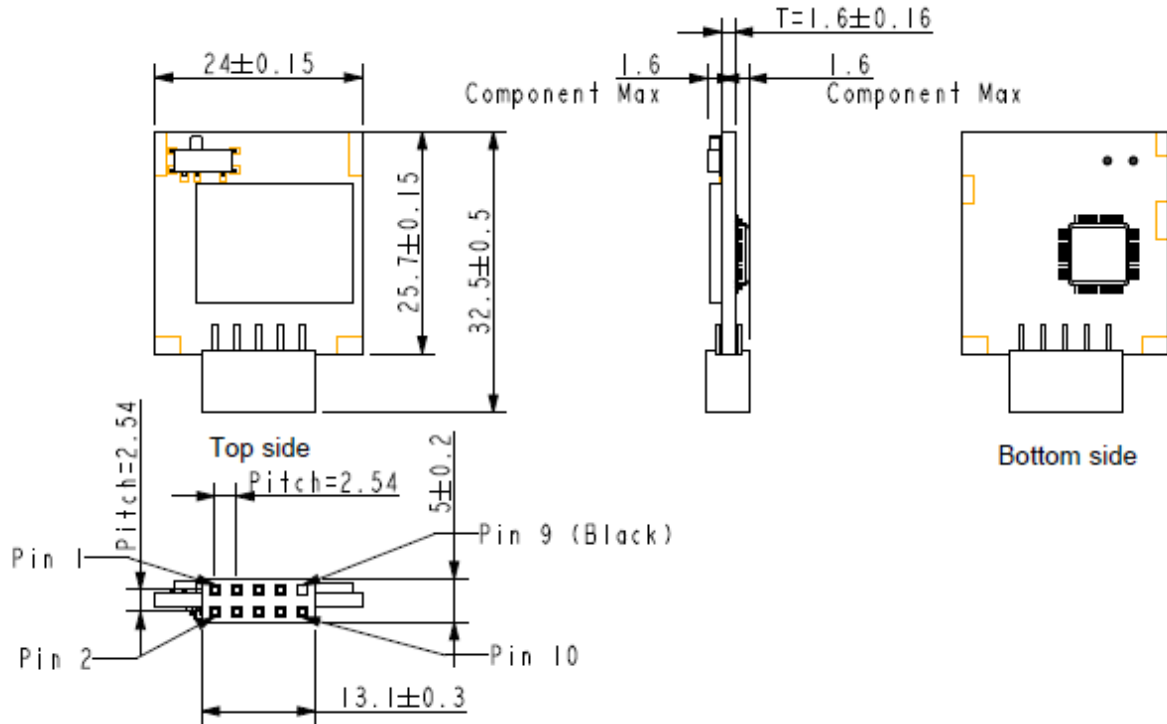

Figure 7-2 Physical Dimensions with Write Protect Switch

7.2 With Housing

Table 7-2 Physical Information with Housing

Parameter	Unit	32 GB	64 GB
Length	mm	35.70	
Width		28.10	
Height (Max.)		7.20	
Weight	g ± 5%	6.91	6.97

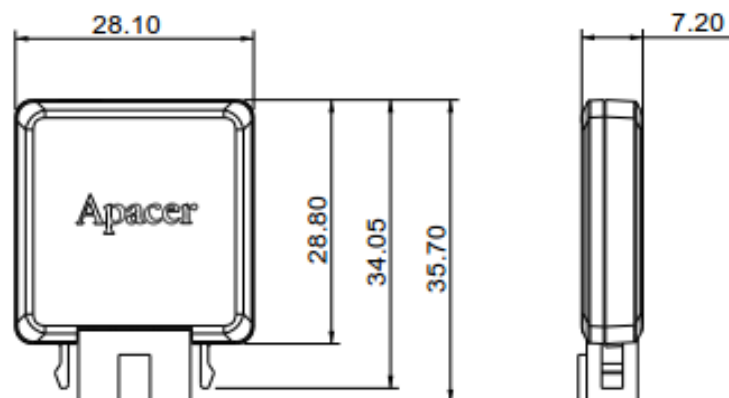

Figure 7-3 Physical Dimensions with Housing

7.3 Write Protect Switch (optional)

Apacer implements the Virtual Write scheme that allows write commands to go through the flash controller and data temporarily stored, but no data has been actually written into the flash. Once the system is reset and rebooted, the temporarily stored data will be lost and nowhere to be found in the system. Since the Virtual Write scheme runs at device level, it requires no software or driver installation and is independent from the host OS.

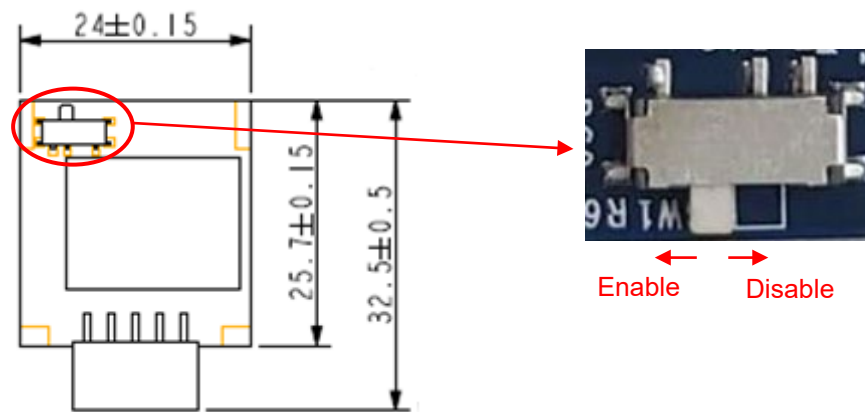

Figure 7-4 Write Protect Switch

7.4 Installation Requirements

Apacer USB-Disk Module comes with two options in mechanical design: with and without housing. Depending on the physical design, requirements of motherboard on which for installing the USB module differ. Before installation, make sure your motherboard has the identical socket design as illustrated below.

7.4.1 Without Housing

The UDM without housing can be inserted into either of the sockets: with or without housing.

Table 7-3 Socket Design for the UDM without Housing

Socket Design	Socket with Housing	Socket without Housing
UDM Design		
		

7.4.2 With Housing

The UDM with housing can only be inserted into the socket with housing, so that the hooks on the sides and the protruding part at the front of the module can snap into place to secure itself to the socket.

Table 7-4 Socket Design for the UDM with Housing

Socket Design	Socket with Housing	Socket without Housing
UDM Design		
		X

8. Product Ordering Information

8.1 Product Code Designations

Apacer's UH110-UFM3 is available in different configurations and densities. See the chart below for a comprehensive list of options for the UH110-UFM3 series devices.

Code	1	2	3	4	5	6	7	8	9	10	11	12	13	14	15	16
	A	P	2	.	1	1	8	X	X	X	.	0	0	1	2	3

Code 1-3 (Product Line & Form Factor)	USB+UFM3
Code 5-6 (Model/Solution)	UH110-UFM3
Code 7-8 (Product Capacity)	8H: 32GB (SLC-liteX) 8J: 64GB (SLC-liteX)
Code 9 (Flash Type & Product Temp)	L: 3D SLC-liteX standard temperature M: 3D SLC-liteX wide temperature
Code 10 (Product Spec)	U: UH110-UFM3 (180D LP) without write protect switch V: UH110-UFM3 (180D LP) with write protect switch W: UH110-UFM3 (180D LPH) without write protect switch Y: UH110-UFM3 (180D LPH) with write protect switch
Code 12-14 (Version Number)	Random numbers generated by system
Code 15-16 (Firmware Version)	UFPA416A

8.2 Valid Combinations

The following tables list the available models of the UH110-UFM3 series which are in mass production or will be in mass production. Consult your Apacer sales representative to confirm availability of valid combinations and to determine availability of new combinations.

8.2.1 Without Housing

Without Write Protect		
Capacity	Standard Temperature	Wide Temperature
32GB	AP2.118HLU.00123	AP2.118HMU.00123
64GB	AP2.118JLU.00123	AP2.118JMU.00123
With Write Protect		
Capacity	Standard Temperature	Wide Temperature
32GB	AP2.118HLV.00123	AP2.118HMV.00123
64GB	AP2.118JLV.00123	AP2.118JMV.00123

8.2.2 With Housing

Without Write Protect		
Capacity	Standard Temperature	Wide Temperature
32GB	AP2.118HLW.00123	AP2.118HMW.00123
64GB	AP2.118JLW.00123	AP2.118JMW.00123
With Write Protect		
Capacity	Standard Temperature	Wide Temperature
32GB	AP2.118HLY.00123	AP2.118HMY.00123
64GB	AP2.118JLY.00123	AP2.118JMY.00123

Revision History

Revision	Description	Date
1.0	Initial release	1/10/2023
1.1	Added support for products designed with housing	9/4/2023

Global Presence

Taiwan (Headquarters)

Apacer Technology Inc.

1F., No.32, Zhongcheng Rd., Tucheng Dist.,
New Taipei City 236, Taiwan R.O.C.
Tel: 886-2-2267-8000
Fax: 886-2-2267-2261
amtsales@apacer.com

Japan

Apacer Technology Corp.

6F, Daiyontamachi Bldg., 2-17-12, Shibaura, Minato-Ku,
Tokyo, 108-0023, Japan
Tel: 81-3-5419-2668
Fax: 81-3-5419-0018
jpservices@apacer.com

China

Apacer Electronic (Shanghai) Co., Ltd

Room D, 22/FL, No.2, Lane 600, JieyunPlaza,
Tianshan RD, Shanghai, 200051, China
Tel: 86-21-6228-9939
Fax: 86-21-6228-9936
sales@apacer.com.cn

U.S.A.

Apacer Memory America, Inc.

46732 Lakeview Blvd., Fremont, CA 94538
Tel: 1-408-518-8699
Fax: 1-510-249-9551
sa@apacerus.com

Europe

Apacer Technology B.V.

Science Park Eindhoven 5051 5692 EB Son,
The Netherlands
Tel: 31-40-267-0000
Fax: 31-40-290-0686
sales@apacer.nl

India

Apacer Technologies Pvt Ltd,

1874, South End C Cross, 9th Block Jayanagar,
Bangalore-560069, India
Tel: 91-80-4152-9061/62
Fax: 91-80-4170-0215
sales_india@apacer.com