

RoHS Recast Compliant **USB-Disk Module 2A** Product Specifications



October 22, 2020

Version 1.3



Apacer Technology Inc.

1F, No.32, Zhongcheng Rd., Tucheng Dist., New Taipei City, Taiwan, R.O.C

Tel: +886-2-2267-8000 Fax: +886-2-2267-2261

www.apacer.com

Specifications Overview:

- **USB2.0 High-Speed and USB1.1 Full-Speed Compatible Interface**
- **Capacity**
 - 256, 512 MB
 - 1, 2, 4, 8, 16, 32 GB
- **Performance***
 - Sequential read: Up to 44 MB/sec
 - Sequential write: Up to 41 MB/sec
 - Random read (4K): Up to 2,400 IOPS
 - Random write (4K): Up to 105 IOPS
- **Flash Management**
 - Flash bad-block management
 - Global Wear Leveling
 - BCH (72 bit) Error Detection Code/Error Correction Code (EDC/ECC)
 - S.M.A.R.T.
- **Supports Non-Removable Setting**
- **NAND Flash Type: SLC**
- **MTBF: >2,000,000 hours**
- **Temperature Range**
 - Operating:
 - Standard: 0°C to 70°C
 - Wide: -40°C to 85°C
 - Storage: -40°C to 100°C
- **Supports Boot-up Function for OS**
 - Windows: WinXP/7 or later
 - Mac: 10.2.8 or later
 - Linux: 2.4.10 or later
- **Power Consumption***
 - Operating voltage: 5V (with a certain percentage of tolerance)
 - Active mode: 110 mA
 - Idle mode: 45 mA
- **Connector**
 - 10-pin (2x5) female header in 2.54mm
- **Write Protect Switch (optional)**
- **RoHS Recast Compliant (2011/65/EU)**

*Varies from capacities. The values for performances and power consumptions presented are typical and may vary depending on flash configurations or platform settings.

Table of Contents

1. General Descriptions	4
1.1 Performance-optimized Controller	4
1.1.1 Error Correction Code (ECC).....	4
1.1.2 Global Wear Leveling	4
1.1.3 Write Protection Mode (optional)	4
2. Functional Block	5
3. Pin Assignments.....	6
3.1 Type A, Type B, and Type C	6
3.2 Type D (STD)	7
4. Product & Reliability Specifications	8
4.1 Capacity Specifications	8
4.2 Performance Specifications	8
4.3 Environmental Specifications	9
4.4 Mean Time Between Failures (MTBF).....	9
4.5 Certification and Compliance.....	9
5. Electrical Specifications.....	10
5.1 Operating Conditions	10
5.2 Absolute Maximum Rating	10
5.3 Power Consumption.....	10
5.4 AC Characteristics	11
6. Physical Dimensions	12
6.1 Horizontal Design	12
6.1.1 Type A (STD 90D)	12
6.1.2 Type B (STD 90D-MH)	13
6.1.3 Type C (STD 90D-MS)	14
6.2 Vertical Design.....	15
6.2.1 Type D (STD 180D)	15
6.3 Write Protect Switch (optional)	16
7. Product Ordering Information.....	17
7.1 Product Code Designations	17
7.2 Valid Combinations	18

7.2.1 Type A (STD 90D) Standard 90 Degree.....	18
7.2.2 Type B (STD 90D-MH) Standard 90 Degree Mounting Header	18
7.2.3 Type C (STD 90D-MS) Standard 90 Degree Mounting Screw	18
7.2.4 Type D (STD 180D) Standard 180 Degree	19
7.2.5 Type A (STD 90D) NR Standard 90 Degree	19
7.2.6 Type B (STD 90D-MH) NR Standard 90 Degree Mounting Header	19
7.2.7 Type C (STD 90D-MS) NR Standard 90 Degree Mounting Screw.....	20
7.2.8 Type D (STD 180D) Standard 180 Degree	20

1. General Descriptions

Apacer's USB-Disk Module (UDM) is a high performance, embedded solid state drive (SSD) designed to replace a conventional IDE hard disk drive. UDM SSD can be plugged into a standard Embedded USB connector commonly found in desktops, portable PC systems and industrial PC systems. This product is well suited for embedded flash storage applications offering new and expanded functionality as well as more cost-effective designs, better performance and increased reliability.

1.1 Performance-optimized Controller

The heart of an UDM is the USB controller, which translates standard USB signals into the data and controls of the flash media. This proprietary USB controller is specifically designed to attain high data throughput from host to flash.

1.1.1 Error Correction Code (ECC)

The UDM uses BCH Error Detection Code (EDC) and Error Correction Code (ECC) algorithms which correct up to 72bit random single-bit errors for each 1024-byte block of data depending on spare area of flash memory. High performance is achieved through hardware-based error detection and correction.

1.1.2 Global Wear Leveling

Flash memory can be erased a limited number of times, This number is called the erase cycle limit, or write endurance limit, The erase cycle limit applies to each individual erase block in the flash device.

In a typical application, and especially if a file system is used, specific pages are constantly updated (e.g., the page that contains the FAT, registry, etc.). Without any special handling, these pages would wear out more rapidly than other pages, reducing the lifetime of the entire flash.

To overcome this inherent deficiency, Apacer's USB-Disk Module (UDM) uses Global Wear Leveling algorithm. This algorithm ensures that consecutive writes of a specific sector are not written physically to the same page in the flash. This spreads flash media usage evenly across all pages, thereby maximizing flash lifetime.

The Global Wear Leveling mechanism provides write/erase cycles for reliable data storage over an extended period.

1.1.3 Write Protection Mode (optional)

When the device is configured to the Write-Protection mode, it enhances the data security and protection. This feature prevents the stored data from inadvertent system writes or erases, and viruses.

2. Functional Block

The USB-Disk Module (UDM) contains a controller, embedded firmware, and Flash Media with a female connector. The UDM interfaces with the host system allowing data to be written to and read from the Flash Media.

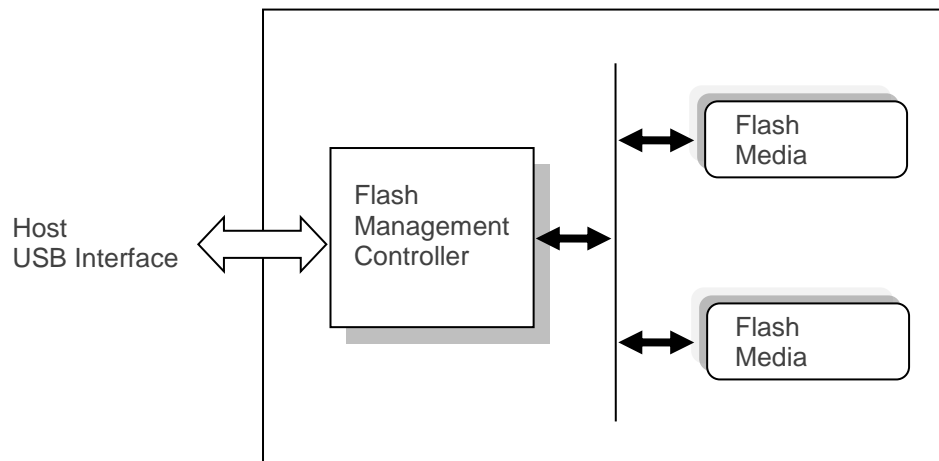

Figure 2-1 Functional Block Diagram

3. Pin Assignments

This chapter provides information on the pin assignments and signal descriptions.

3.1 Type A, Type B, and Type C

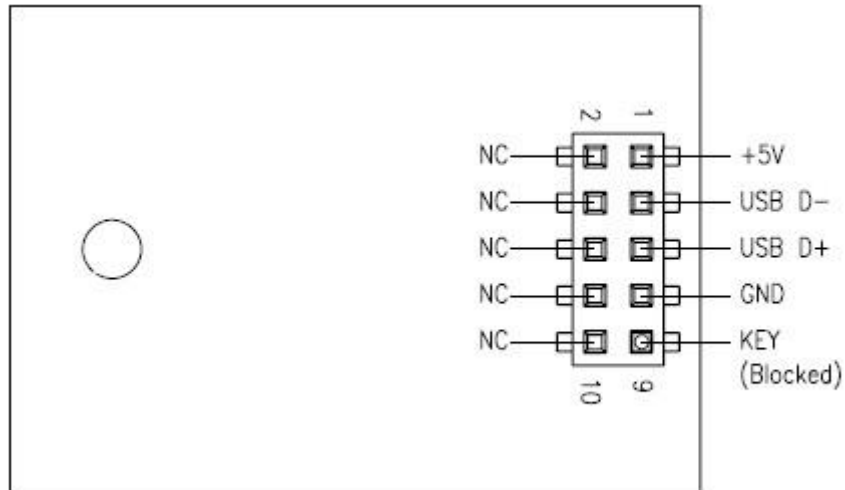

Table 3-1 Pin Assignment of the 10-Pin Configuration in Type A, Type B, and Type C.

Pin	Signal	Pin	Signal
1	+5V	2	N.C
3	USB D-	4	N.C
5	USB D+	6	N.C
7	GND	8	N.C
9	Key (Blocked)	10	N.C

3.2 Type D (STD)

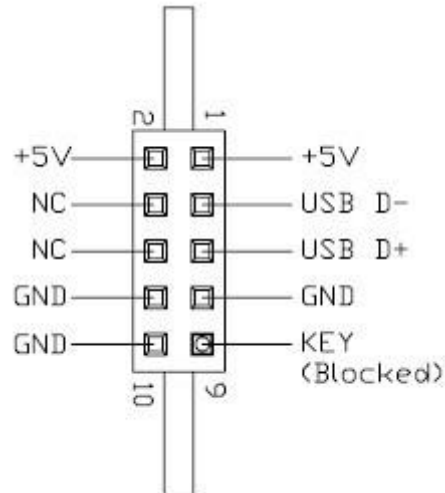

Table 3-2 Pin Assignment of the 10-Pin Configuration in Type D (STD)

Pin	Signal	Pin	Signal
1	+5V	2	+5V
3	USB D-	4	N.C
5	USB D+	6	N.C
7	GND	8	GND
9	Key (Blocked)	10	GND

4. Product & Reliability Specifications

4.1 Capacity Specifications

The USB-Disk Module product family is available as shown in Table 4-1.

Table 4-1 Capacity Specifications

Capacity	Total Bytes
256MB	250,314,752
512 MB	500,924,416
1GB	998,998,016
2GB	2,001,502,208
4GB	4,001,382,400
8GB	8,002,748,416
16GB	16,022,257,664
32GB	32,010,944,512

Note: The number of total bytes may vary depending on the file system in use.

4.2 Performance Specifications

Performance of the USB-Disk Module product is listed below in Table 4-2.

Table 4-2 Performance Specifications

Capacity	256 MB	512 MB	1 GB	2 GB	4 GB	8 GB	16 GB	32 GB
Sequential Read* (MB/s)	44	44	44	44	44	44	44	44
Sequential Write* (MB/s)	10	20	35	36	38	40	41	41
Random Read IOPS** (4K)	2,400	2,400	2,000	1,900	1,800	1,700	1,600	1,600
Random Write IOPS** (4K)	45	60	50	50	70	80	105	105

Note:

Results may differ from various flash configurations or host system setting.

*Sequential performance is based on CrystalDiskMark 5.2.1 with file size 1,000MB.

**Random performance measured using IOMeter with Queue Depth 32.

4.3 Environmental Specifications

Environmental specification of the USB-Disk Module product family is available as shown in Table 4-3.

Table 4-3 Environmental Specifications

Item	Specifications	
Temperature	Operation	0°C to 70°C (Standard); -40°C to 85°C (Wide)
	Storage	-40°C to 100°C
Shock	Operating	50(G)/11(ms)/half sine (compliant with MIL-STD-202G)
	Non-operating	1,500(G)/0.5(ms)/half sine (compliant with MIL-STD-202G)
Vibration	Operating	7.69(Grms), 20~2000(Hz)/random (compliant with MIL-STD-810G)
	Non-operating	4.02(Grms), 15~2000(Hz)/random (compliant with MIL-STD-810G)
EMC	FCC, CE	

4.4 Mean Time Between Failures (MTBF)

Mean Time Between Failures (MTBF) is predicted based on reliability data for the individual components in Apacer’s USB flash drive. Serving as statistical reference, the prediction result for Apacer’s USB is more than 2,000,000 hours.

Note: The MTBF is predicated and calculated based on “Telcordia Technologies Special Report, SR-332, Issue 2” method.

4.5 Certification and Compliance

The USB-Disk Module (UDM) complies with the following standards:

- CE
- FCC
- RoHS Recast
- MIL-STD-810

5. Electrical Specifications

5.1 Operating Conditions

Table 5-1 lists the absolute stress rating for the USB-Disk Module.

Caution: Absolute Maximum Stress Ratings – Applied conditions greater than those listed under “Absolute Maximum Stress Ratings” may cause permanent damage to the device. This is a stress rating only and functional operation of the device at these conditions or conditions greater than those defined in the operational sections of this data sheet is not implied. Exposure to absolute maximum stress rating conditions may affect device reliability.

Table 5-1 Operating Range

Range	Ambient Temperature	Voltage
Standard Temperature	0°C to 70°C	4.5-5.5V
Wide Temperature	-40°C to 85°C	

5.2 Absolute Maximum Rating

Table 5-2 lists the absolute maximum power ratings for the USB-Disk Module.

Table 5-2 Absolute maximum power pin stress ratings

Parameter	Symbol	Min	Max	Unit
Power Supply Input	VDD- VSS	-0.3	5.5	V
Voltage on any pin except VDD with respect to GND	VIN	-ss - 0.3	VDD +0.3	V

5.3 Power Consumption

Table 5-3 lists the power consumption for the USB-Disk Module.

Table 5-3 Power Consumption

Capacity Mode	216 MB	512 MB	1 GB	2GB	4 GB	8 GB	16 GB	32 GB
	Active (mA)	85	85	95	105	100	95	95
Standby (mA)	40	40	40	45	40	40	40	45

Note:

*All values are typical and may vary depending on flash configurations or host system settings.

**Active power is an average power measurement performed using CrystalDiskMark with 128KB sequential read/write transfers.

5.4 AC Characteristics

Table 5-4 AC Characteristics Full Speed

Parameter	Symbol	Min	Typ	Max	Unit
Rise Time	T_{FR}	4	—	20	ns
Fall Time	T_{FF}	4	—	20	ns
Differential Rise and Fall Time Matching	T_{FRFM}	90		111.11	%
Driver Output Resistance	Z_{DRV}	28	—	44	Ω

Table 5-5 AC Characteristics High Speed

Parameter	Symbol	Min	Typ	Max	Unit
Rise Time (10%~90%)	T_{HSR}	500	—	—	ps
Fall Time (10%~90%)	T_{HSF}	500	—	—	ps
Driver Output Resistance	Z_{HSDRV}	40.5	—	49.5	Ω

6. Physical Dimensions

6.1 Horizontal Design

6.1.1 Type A (STD 90D)

Standard 90 Degree

Length	Width	Height (Max)
28.8 mm	26.65 mm	10.76 mm

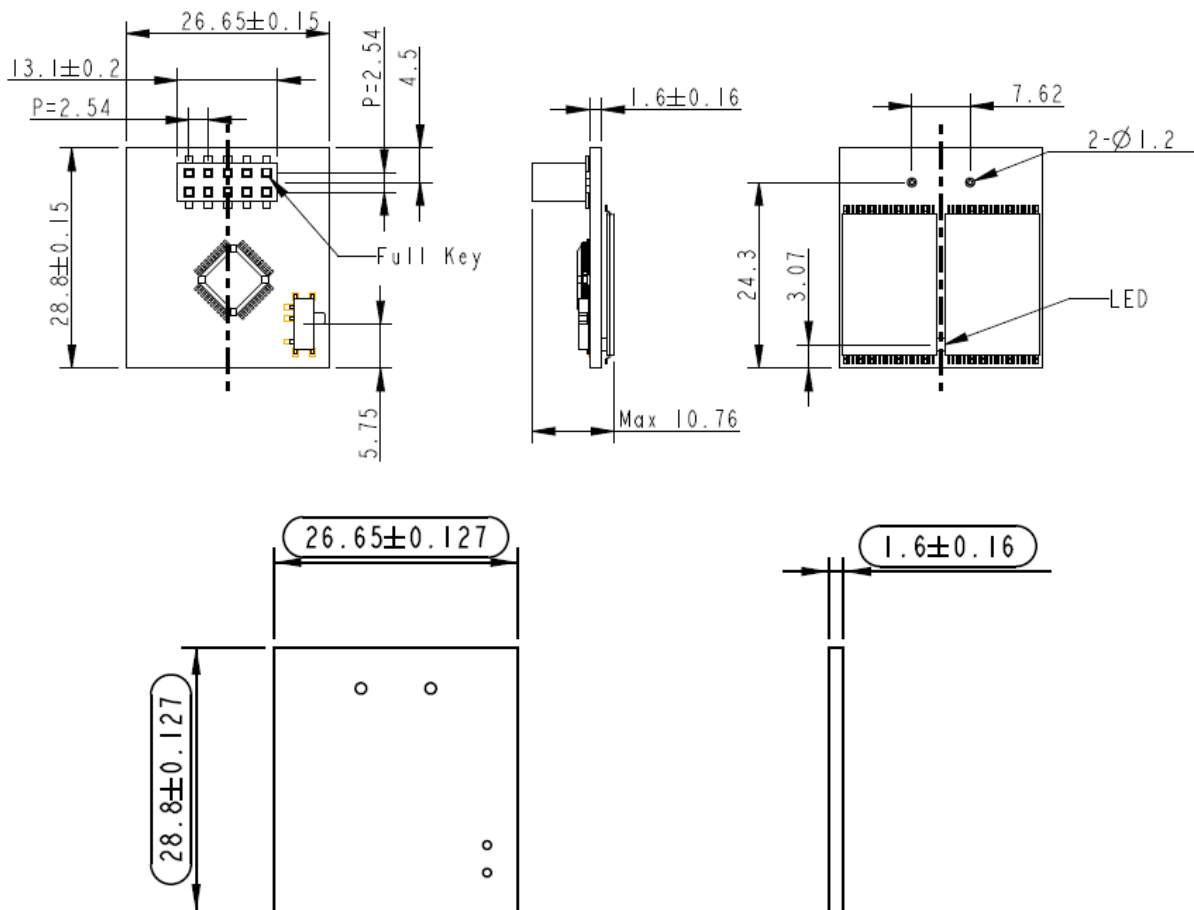

Unit: mm
Tolerance: ± 0.2

6.1.3 Type C (STD 90D-MS)

Standard 90 Degree Mounting Screw

Length	Width	Height (Max)
37.8 mm	26.65 mm	10.76 mm

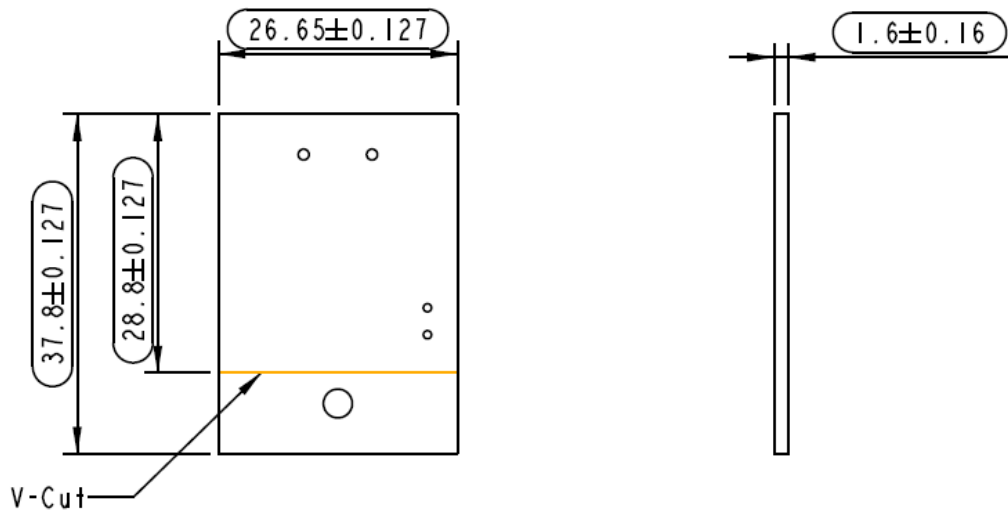
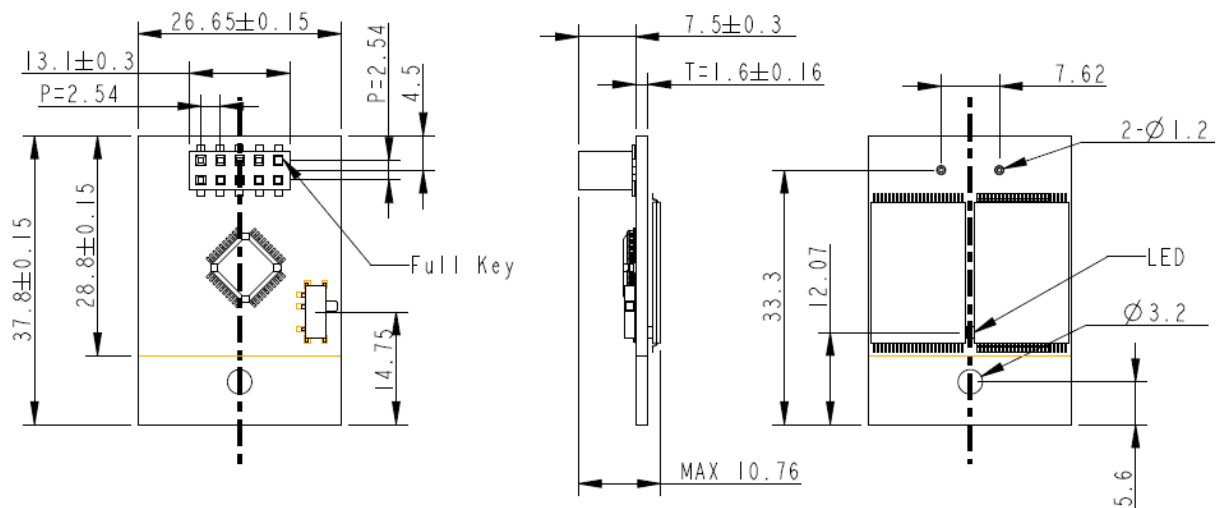

Unit: mm
Tolerance: ± 0.2

6.2 Vertical Design

6.2.1 Type D (STD 180D)

Standard 180 Degree

Length	Width	Height (Max)
36.8 mm	26.65 mm	5 mm

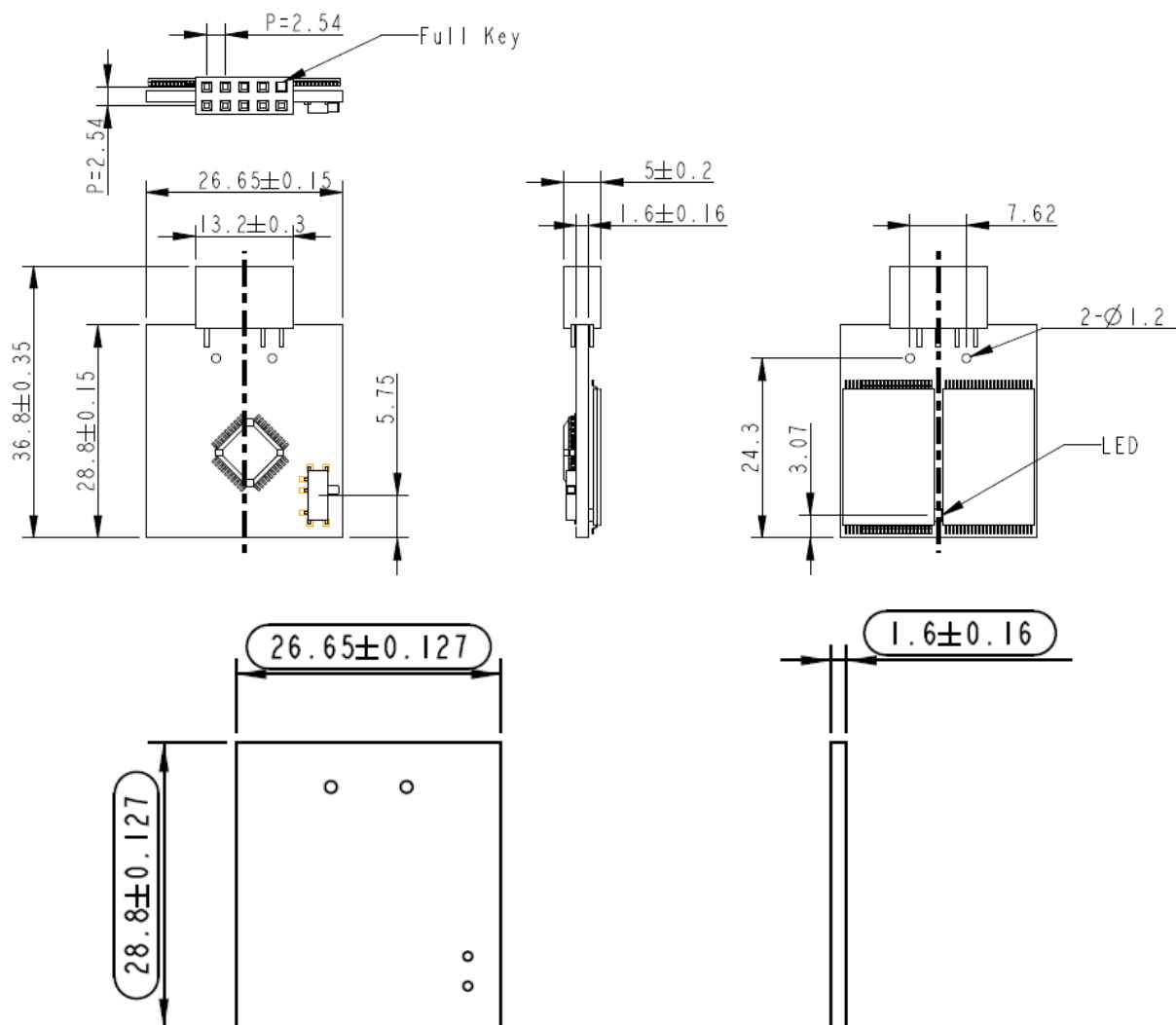

Unit: mm
Tolerance: ± 0.2

6.3 Write Protect Switch (optional)

Apacer implements the Virtual Write scheme that allows write commands to go through the flash controller and data temporarily stored, but no data has been actually written into the flash. Once the system is reset and rebooted, the temporarily stored data will be lost and nowhere to be found in the system. Since the Virtual Write scheme runs at device level, it requires no software or driver installation and is independent from the host OS.

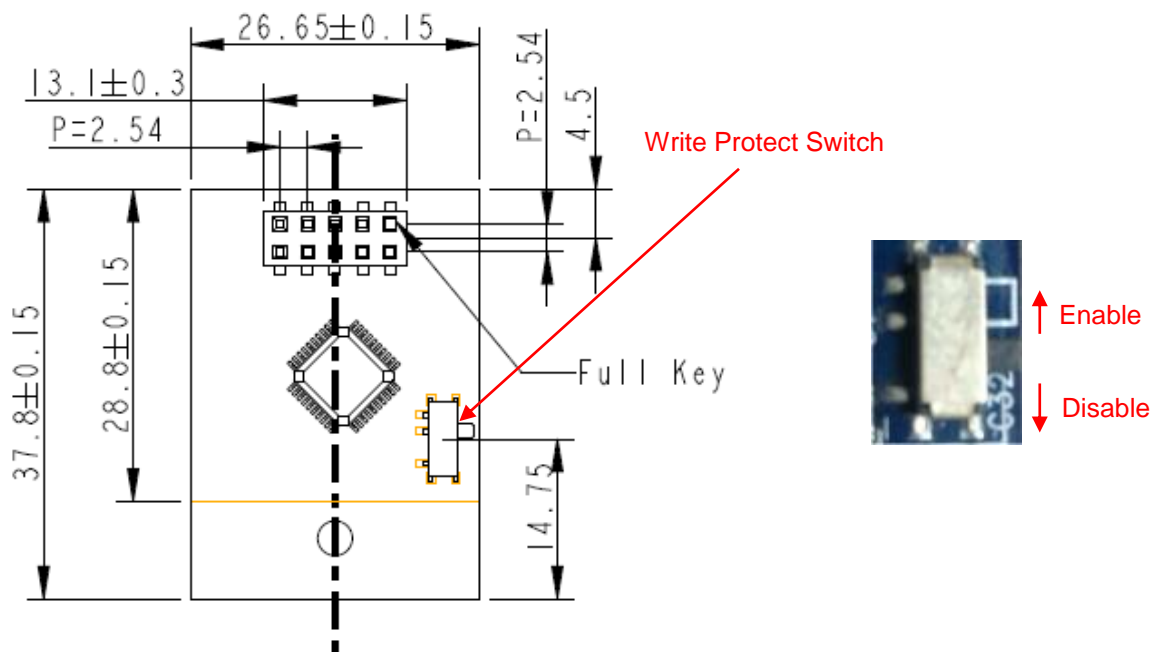

7. Product Ordering Information

7.1 Product Code Designations

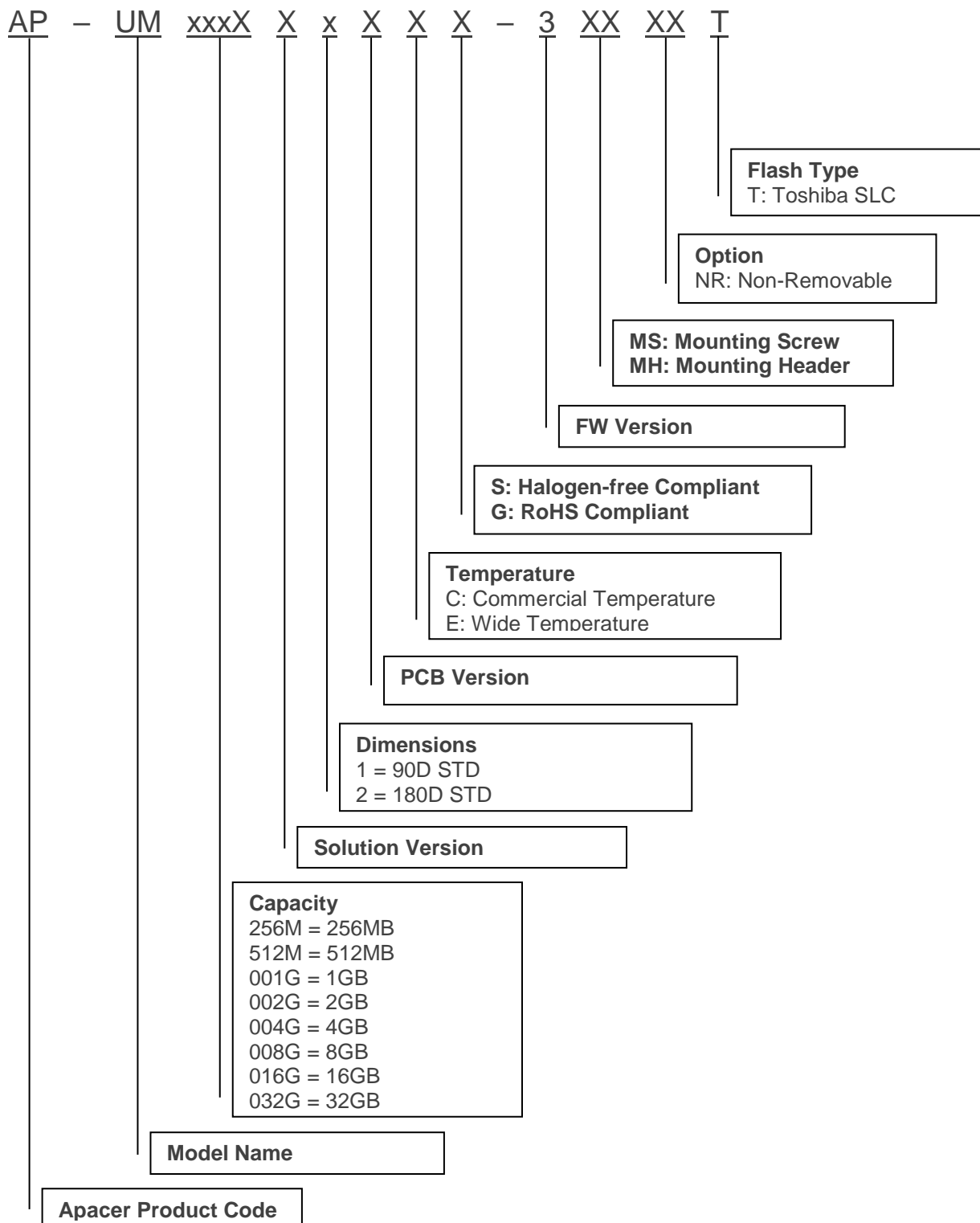

7.2 Valid Combinations

7.2.1 Type A (STD 90D) Standard 90 Degree

Capacity	Standard Temperature	Wide Temperature
256MB	AP-UM256MA11CS-3T	AP-UM256MA11ES-3T
512MB	AP-UM512MA11CS-3T	AP-UM512MA11ES-3T
1GB	AP-UM001GA11CS-3T	AP-UM001GA11ES-3T
2GB	AP-UM002GA11CS-3T	AP-UM002GA11ES-3T
4GB	AP-UM004GA11CS-3T	AP-UM004GA11ES-3T
8GB	AP-UM008GA11CS-3T	AP-UM008GA11ES-3T
16GB	AP-UM016GA11CS-3T	AP-UM016GA11ES-3T
32GB	AP-UM032GA11CS-3T	AP-UM032GA11ES-3T

7.2.2 Type B (STD 90D-MH) Standard 90 Degree Mounting Header

Capacity	Standard Temperature	Wide Temperature
256MB	AP-UM256MA11CS-3MHT	AP-UM256MA11ES-3MHT
512MB	AP-UM512MA11CS-3MHT	AP-UM512MA11ES-3MHT
1GB	AP-UM001GA11CS-3MHT	AP-UM001GA11ES-3MHT
2GB	AP-UM002GA11CS-3MHT	AP-UM002GA11ES-3MHT
4GB	AP-UM004GA11CS-3MHT	AP-UM004GA11ES-3MHT
8GB	AP-UM008GA11CS-3MHT	AP-UM008GA11ES-3MHT
16GB	AP-UM016GA11CS-3MHT	AP-UM016GA11ES-3MHT
32GB	AP-UM032GA11CS-3MHT	AP-UM032GA11ES-3MHT

7.2.3 Type C (STD 90D-MS) Standard 90 Degree Mounting Screw

Capacity	Standard Temperature	Wide Temperature
256MB	AP-UM256MA11CS-3MST	AP-UM256MA11ES-3MST
512MB	AP-UM512MA11CS-3MST	AP-UM512MA11ES-3MST
1GB	AP-UM001GA11CS-3MST	AP-UM001GA11ES-3MST
2GB	AP-UM002GA11CS-3MST	AP-UM002GA11ES-3MST
4GB	AP-UM004GA11CS-3MST	AP-UM004GA11ES-3MST
8GB	AP-UM008GA11CS-3MST	AP-UM008GA11ES-3MST
16GB	AP-UM016GA11CS-3MST	AP-UM016GA11ES-3MST
32GB	AP-UM032GA11CS-3MST	AP-UM032GA11ES-3MST

7.2.4 Type D (STD 180D) Standard 180 Degree

Capacity	Standard Temperature	Wide Temperature
256MB	AP-UM256MA21CS-3T	AP-UM256MA21ES-3T
512MB	AP-UM512MA21CS-3T	AP-UM512MA21ES-3T
1GB	AP-UM001GA21CS-3T	AP-UM001GA21ES-3T
2GB	AP-UM002GA21CS-3T	AP-UM002GA21ES-3T
4GB	AP-UM004GA21CS-3T	AP-UM004GA21ES-3T
8GB	AP-UM008GA21CS-3T	AP-UM008GA21ES-3T
16GB	AP-UM016GA21CS-3T	AP-UM016GA21ES-3T
32GB	AP-UM032GA21CS-3T	AP-UM032GA21ES-3T

7.2.5 Type A (STD 90D) NR Standard 90 Degree

Capacity	Standard Temperature	Wide Temperature
256MB	AP-UM256MA11CS-3NRT	AP-UM256MA11ES-3NRT
512MB	AP-UM512MA11CS-3NRT	AP-UM512MA11ES-3NRT
1GB	AP-UM001GA11CS-3NRT	AP-UM001GA11ES-3NRT
2GB	AP-UM002GA11CS-3NRT	AP-UM002GA11ES-3NRT
4GB	AP-UM004GA11CS-3NRT	AP-UM004GA11ES-3NRT
8GB	AP-UM008GA11CS-3NRT	AP-UM008GA11ES-3NRT
16GB	AP-UM016GA11CS-3NRT	AP-UM016GA11ES-3NRT
32GB	AP-UM032GA11CS-3NRT	AP-UM032GA11ES-3NRT

7.2.6 Type B (STD 90D-MH) NR Standard 90 Degree Mounting Header

Capacity	Standard Temperature	Wide Temperature
256MB	AP-UM256MA11CS-3MHNRT	AP-UM256MA11ES-3MHNRT
512MB	AP-UM512MA11CS-3MHNRT	AP-UM512MA11ES-3MHNRT
1GB	AP-UM001GA11CS-3MHNRT	AP-UM001GA11ES-3MHNRT
2GB	AP-UM002GA11CS-3MHNRT	AP-UM002GA11ES-3MHNRT
4GB	AP-UM004GA11CS-3MHNRT	AP-UM004GA11ES-3MHNRT
8GB	AP-UM008GA11CS-3MHNRT	AP-UM008GA11ES-3MHNRT
16GB	AP-UM016GA11CS-3MHNRT	AP-UM016GA11ES-3MHNRT
32GB	AP-UM032GA11CS-3MHNRT	AP-UM032GA11ES-3MHNRT

7.2.7 Type C (STD 90D-MS) NR Standard 90 Degree Mounting Screw

Capacity	Standard Temperature	Wide Temperature
256MB	AP-UM256MA11CS-3MSNRT	AP-UM256MA11ES-3MSNRT
512MB	AP-UM512MA11CS-3MSNRT	AP-UM512MA11ES-3MSNRT
1GB	AP-UM001GA11CS-3MSNRT	AP-UM001GA11ES-3MSNRT
2GB	AP-UM002GA11CS-3MSNRT	AP-UM002GA11ES-3MSNRT
4GB	AP-UM004GA11CS-3MSNRT	AP-UM004GA11ES-3MSNRT
8GB	AP-UM008GA11CS-3MSNRT	AP-UM008GA11ES-3MSNRT
16GB	AP-UM016GA11CS-3MSNRT	AP-UM016GA11ES-3MSNRT
32GB	AP-UM032GA11CS-3MSNRT	AP-UM032GA11ES-3MSNRT

7.2.8 Type D (STD 180D) Standard 180 Degree

Capacity	Standard Temperature	Wide Temperature
256MB	AP-UM256MA21CS-3NRT	AP-UM256MA21ES-3NRT
512MB	AP-UM512MA21CS-3NRT	AP-UM512MA21ES-3NRT
1GB	AP-UM001GA21CS-3NRT	AP-UM001GA21ES-3NRT
2GB	AP-UM002GA21CS-3NRT	AP-UM002GA21ES-3NRT
4GB	AP-UM004GA21CS-3NRT	AP-UM004GA21ES-3NRT
8GB	AP-UM008GA21CS-3NRT	AP-UM008GA21ES-3NRT
16GB	AP-UM016GA21CS-3NRT	AP-UM016GA21ES-3NRT
32GB	AP-UM032GA21CS-3NRT	AP-UM032GA21ES-3NRT

Note: Valid combinations are those products in mass production or will be in mass production. Consult your Apacer sales representative to confirm availability of valid combinations and to determine availability of new combinations.

Revision History

Revision	Description	Date
0.1	Preliminary release	4/6/2017
1.0	Official release	8/4/2017
1.1	- Removed Extended Data Protection and added Write Protect Switch (optional) on Features page - Added 6.3 Write Protect Switch (optional)	11/15/2017
1.2	- Renamed extended temperature to wide temperature - Updated Table 4-3 by changing storage temperature from -40°C to 85°C to -40°C to 100°C	8/14/2020
1.3	Updated mechanical specs for all types of models at 6. Physical Dimensions	10/22/2020

Global Presence

Taiwan (Headquarters)

Apacer Technology Inc.

1F., No.32, Zhongcheng Rd., Tucheng Dist.,
New Taipei City 236, Taiwan R.O.C.
Tel: 886-2-2267-8000
Fax: 886-2-2267-2261
amtsales@apacer.com

U.S.A.

Apacer Memory America, Inc.

46732 Lakeview Blvd., Fremont, CA 94538
Tel: 1-408-518-8699
Fax: 1-510-249-9551
sa@apacerus.com

Japan

Apacer Technology Corp.

6F, Daiyontamachi Bldg., 2-17-12, Shibaura, Minato-Ku,
Tokyo, 108-0023, Japan
Tel: 81-3-5419-2668
Fax: 81-3-5419-0018
jpservices@apacer.com

Europe

Apacer Technology B.V.

Science Park Eindhoven 5051 5692 EB Son,
The Netherlands
Tel: 31-40-267-0000
Fax: 31-40-290-0686
sales@apacer.nl

China

Apacer Electronic (Shanghai) Co., Ltd

Room D, 22/FL, No.2, Lane 600, JieyunPlaza,
Tianshan RD, Shanghai, 200051, China
Tel: 86-21-6228-9939
Fax: 86-21-6228-9936
sales@apacer.com.cn

India

Apacer Technologies Pvt Ltd,

1874, South End C Cross, 9th Block Jayanagar,
Bangalore-560069, India
Tel: 91-80-4152-9061/62
Fax: 91-80-4170-0215
sales_india@apacer.com