

RoHS Recast Compliant

## USB-Disk Module 2A-M

Low-Profile 180D Product Specifications



December 14, 2017

Version 1.0



**Apacer Technology Inc.**

1F, No.32, Zhongcheng Rd., Tucheng Dist., New Taipei City, Taiwan, R.O.C

Tel: +886-2-2267-8000 Fax: +886-2-2267-2261

[www.apacer.com](http://www.apacer.com)

## Features:

- **USB2.0 High-Speed and USB1.1 Full-Speed Compatible Interface**
- **Capacity**
  - 8, 16, 32, 64, 128 GB
- **Performance\***
  - Sequential read: Up to 44 MB/sec
  - Sequential write: Up to 43 MB/sec
  - Random read (4K): Up to 2,300 IOPS
  - Random write (4K): Up to 190 IOPS
- **Flash Management**
  - Flash bad-block management
  - Global Wear Leveling
  - BCH (72 bit) Error Detection Code/Error Correction Code (EDC/ECC)
  - S.M.A.R.T.
- **S.M.A.R.T. Support**
- **NAND Flash Type: MLC**
- **MTBF: >1,000,000 hours**
- **Temperature Range**
  - Operating:
    - Standard: 0°C to 70°C
    - Extended: -40°C to 85°C
  - Storage: -40°C to 100°C
- **Support Boot-up Function for OS**
  - Windows: WinXP/7 or later
  - Mac: 10.2.8 or later
  - Linux: 2.4.10 or later
- **Power Consumption\***
  - Operating voltage: 5V (with a certain percentage of tolerance)
  - Active mode: 125 mA
  - Idle mode: 50 mA
- **Connector**
  - 10-pin (2x5) female header in 2.45mm
- **Support Non-Removable Setting**
- **Write Protect Switch (optional)**
- **RoHS Recast Compliant (2011/65/EU)**

\*Varies from capacities. The values for performances and power consumptions presented are typical and may vary depending on flash configurations or platform settings.

## Table of Contents

<b>1. General Descriptions .....</b>	<b>3</b>
1.1 Performance-Optimized Controller .....	3
1.1.1 Error Correction Code (ECC).....	3
1.1.2 Global Wear Leveling .....	3
1.1.3 Write Protection Mode (optional) .....	3
<b>2. Functional Block .....</b>	<b>4</b>
<b>3. Pin Assignments.....</b>	<b>5</b>
3.1 Without Housing .....	5
3.2 With Housing .....	6
<b>4. Product &amp; Reliability Specifications .....</b>	<b>7</b>
4.1 Capacity Specifications .....	7
4.2 Performance Specifications.....	7
4.3 Environmental Specifications .....	7
4.4 Mean Time Between Failures (MTBF) .....	8
4.5 Certification and Compliance .....	8
<b>5. Electrical Specifications .....</b>	<b>9</b>
5.1 Operating Conditions.....	9
5.2 AC Characteristics.....	10
<b>6. Physical Dimensions .....</b>	<b>11</b>
6.1 Without Housing .....	11
6.2 With Housing .....	12
6.3 Write Protect Switch (optional) .....	13
<b>7. Product Ordering Information.....</b>	<b>14</b>
7.1 Product Code Designations.....	14
7.2 Valid Combinations.....	15
7.2.1 Low Profile 180 Degree .....	15
7.2.2 LPH Low Profile 180 Degree .....	15

# 1. General Descriptions

Apacer's USB-Disk Module (UDM) is a high performance, embedded solid state drive (SSD) designed to replace a conventional IDE hard disk drive. UDM SSD can be plugged into a standard Embedded USB connector commonly found in desktops, portable PC systems and industrial PC systems. This product is well suited for embedded flash storage applications offering new and expanded functionality as well as more cost-effective designs, better performance and increased reliability.

## 1.1 Performance-Optimized Controller

The heart of an UDM is the USB controller, which translates standard USB signals into the data and controls of the flash media. This proprietary USB controller is specifically designed to attain high data throughput from host to flash.

### 1.1.1 Error Correction Code (ECC)

The UDM uses BCH Error Detection Code (EDC) and Error Correction Code (ECC) algorithms which correct up to 72bit random single-bit errors for each 1024-byte block of data depending on spare area of flash memory. High performance is achieved through hardware-based error detection and correction.

### 1.1.2 Global Wear Leveling

Flash memory can be erased a limited number of times, This number is called the erase cycle limit, or write endurance limit, The erase cycle limit applies to each individual erase block in the flash device.

In a typical application, and especially if a file system is used, specific pages are constantly updated (e.g., the page that contains the FAT, registry, etc.). Without any special handling, these pages would wear out more rapidly than other pages, reducing the lifetime of the entire flash.

To overcome this inherent deficiency, Apacer's USB-Disk Module (UDM) uses Global Wear Leveling algorithm. This algorithm ensures that consecutive writes of a specific sector are not written physically to the same page in the flash. This spreads flash media usage evenly across all pages, thereby maximizing flash lifetime.

The Global Wear Leveling mechanism provides write/erase cycles for reliable data storage over an extended period.

### 1.1.3 Write Protection Mode (optional)

When the device is configured to the Write-Protection mode, it enhances the data security and protection. This feature prevents the stored data from inadvertent system writes or erases, and viruses.

## 2. Functional Block

The USB-Disk Module (UDM) contains a controller, embedded firmware, and Flash Media with a female connector. The UDM interfaces with the host system allowing data to be written to and read from the Flash Media.

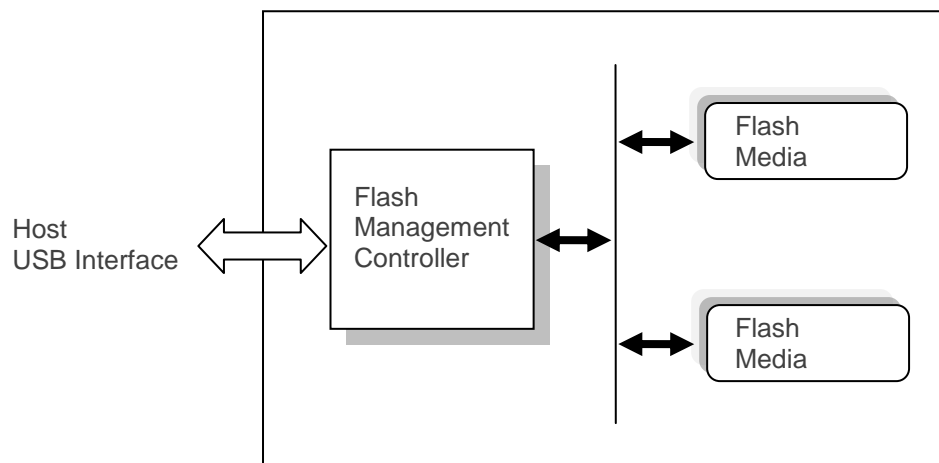
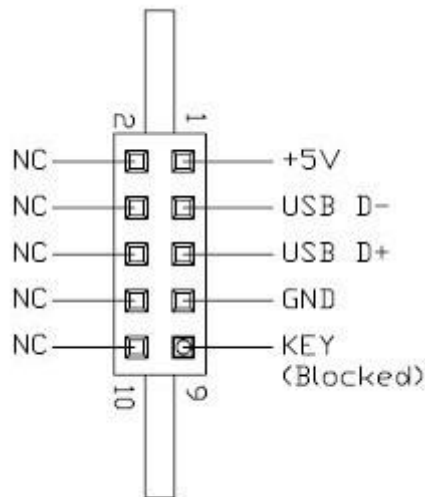

Figure 2-1 Functional Block Diagram

### 3. Pin Assignments

This chapter provides information on the pin assignments and signal descriptions.

#### 3.1 Without Housing



**Table 3-1** Pin Assignment of the 10-Pin Configuration in Type D (LP)

Pin	Signal	Pin	Signal
1	+5V	2	N.C
3	USB D-	4	N.C
5	USB D+	6	N.C
7	GND	8	N.C
9	Key (Blocked)	10	N.C

### 3.2 With Housing



**Table 3-2** Pin Assignment of the 10-Pin Configuration

Pin	Signal	Pin	Signal
1	+5V	2	+5V
3	USB D-	4	N.C
5	USB D+	6	N.C
7	GND	8	GND
9	Key (Blocked)	10	GND

## 4. Product & Reliability Specifications

### 4.1 Capacity Specifications

The USB-Disk Module product family is available as shown in Table 4-1.

**Table 4-1** Capacity Specifications

Capacity	Total Bytes
8GB	8,002,748,416
16GB	16,022,257,664
32GB	32,010,944,512
64GB	64,021,889,024
128GB	128,043,745,280

Note: The number of total bytes may vary depending on the file system in use.

### 4.2 Performance Specifications

Performance of the USB-Disk Module product is listed below in Table 4-2.

**Table 4-2** Performance Specifications

Performance	Capacity	8 GB	16 GB	32 GB	64 GB	128 GB
	<b>Sequential Read* (MB/s)</b>		44	44	44	44
<b>Sequential Write* (MB/s)</b>		26	42	42	42	43
<b>Random Read IOPS** (4K)</b>		1,900	1,800	1,800	1,700	2,300
<b>Random Write IOPS** (4K)</b>		100	115	95	190	35

Note:

Results may differ from various flash configurations or host system setting.

\*Sequential performance is based on CrystalDiskMark 5.2.1 with file size 1,000MB.

\*\*Random performance measured using IOMeter with Queue Depth 32.

### 4.3 Environmental Specifications

Environmental specification of the USB-Disk Module product family is available as shown in Table 4-3.

**Table 4-3** Environmental Specifications

Item	Specifications	
Temperature	Operation	0°C to 70°C (Standard); -40°C to 85°C (Extended)
	Storage	-40°C to 85°C
Shock	Operating	50(G)/11(ms)/half sine (compliant with MIL-STD-202G)
	Non-operating	1,500(G)/0.5(ms)/half sine (compliant with MIL-STD-202G)
Vibration	Operating	7.69(Grms), 20~2000(Hz)/random (compliant with MIL-STD-810G)
	Non-operating	4.02(Grms), 15~2000(Hz)/random (compliant with MIL-STD-810G)
EMC	FCC, CE	

## 4.4 Mean Time Between Failures (MTBF)

Mean Time Between Failures (MTBF) is predicted based on reliability data for the individual components in Apacer's USB flash drive. Serving as statistical reference, the prediction result for Apacer's USB is more than 1,000,000 hours.

Note: The MTBF is predicated and calculated based on "Telcordia Technologies Special Report, SR-332, Issue 2" method.

## 4.5 Certification and Compliance

The USB-Disk Module (UDM) complies with the following standards:

- CE
- FCC
- RoHS Recast
- MIL-STD-810

## 5. Electrical Specifications

### 5.1 Operating Conditions

**Caution: Absolute Maximum Stress Ratings** – Applied conditions greater than those listed under “Absolute Maximum Stress Ratings” may cause permanent damage to the device. This is a stress rating only and functional operation of the device at these conditions or conditions greater than those defined in the operational sections of this data sheet is not implied. Exposure to absolute maximum stress rating conditions may affect device reliability.

**Table 5-1** Operating Range

Range	Ambient Temperature	Voltage
Standard Temperature	0°C to 70°C	4.5-5.5V
Extended Temperature	-40°C to 85°C	

**Table 5-2** Absolute maximum power pin stress ratings

Parameter	Symbol	Min	Max	Unit
Power Supply Input	VDD- VSS	-0.3	5.5	V
Voltage on any pin except VDD with respect to GND	VIN	-ss - 0.3	VDD +0.3	V

**Table 5-3** Power Consumption

Mode \ Capacity	Capacity				
	8 GB	16 GB	32 GB	64 GB	128 GB
Active (mA)	85	110	110	120	125
Standby (mA)	47	49	49	50	50

Note:

\*All values are typical and may vary depending on flash configurations or host system settings.

\*\*Active power is an average power measurement performed using CrystalDiskMark with 128KB sequential read/write transfers.

## 5.2 AC Characteristics

**Table 5-4 AC Characteristics Full Speed**

Parameter	Symbol	Min	Typ	Max	Unit
Rise Time	$T_{FR}$	4	—	20	ns
Fall Time	$T_{FF}$	4	—	20	ns
Differential Rise and Fall Time Matching	$T_{FRFM}$	90		111.11	%
Driver Output Resistance	$Z_{DRV}$	28	—	44	$\Omega$

**Table 5-5 AC Characteristics High Speed**

Parameter	Symbol	Min	Typ	Max	Unit
Rise Time (10%~90%)	$T_{HSR}$	500	—	—	ps
Fall Time (10%~90%)	$T_{HSF}$	500	—	—	ps
Driver Output Resistance	$Z_{HSDRV}$	40.5	—	49.5	$\Omega$

## 6. Physical Dimensions

### 6.1 Without Housing

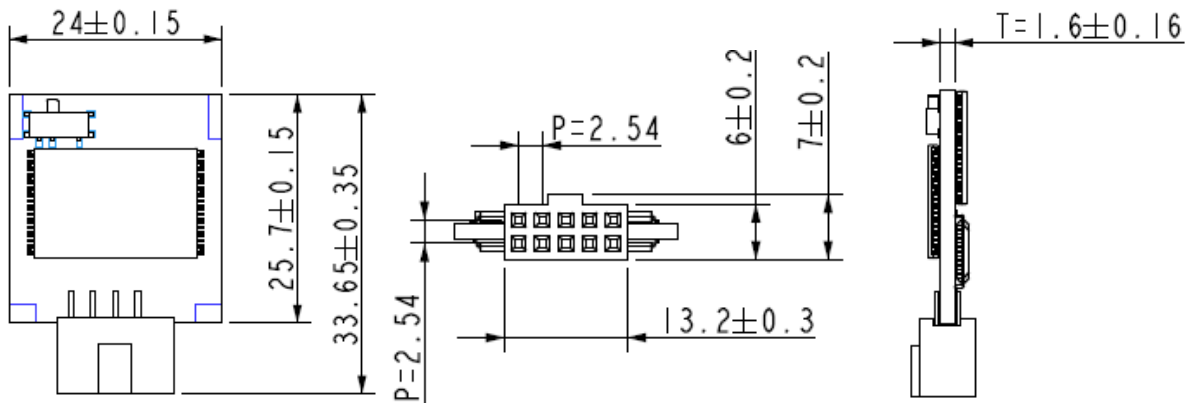

Note: Write Protect switch is optional.

Unit: mm Tolerance: $\pm 0.2$
----------------------------------

## 6.2 With Housing

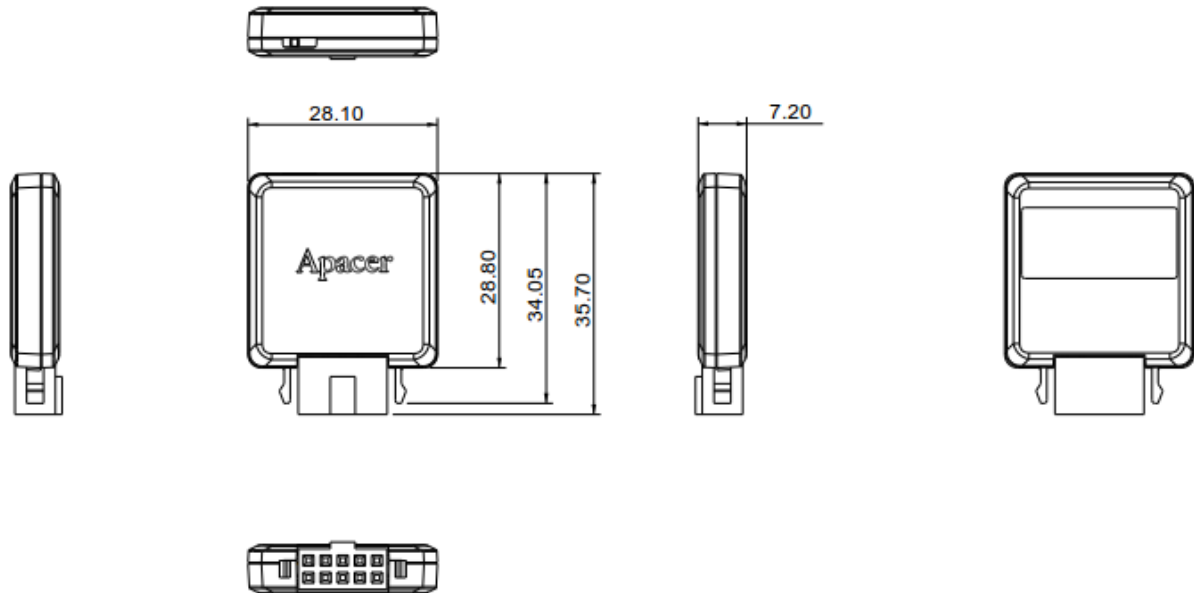

Note: Write Protect switch is optional.

Unit: mm  
Tolerance:  $\pm 0.2$

### 6.3 Write Protect Switch (optional)

Apacer implements the Virtual Write scheme that allows write commands to go through the flash controller and data temporarily stored, but no data has been actually written into the flash. Once the system is reset and rebooted, the temporarily stored data will be lost and nowhere to be found in the system. Since the Virtual Write scheme runs at device level, it requires no software or driver installation and is independent from the host OS.

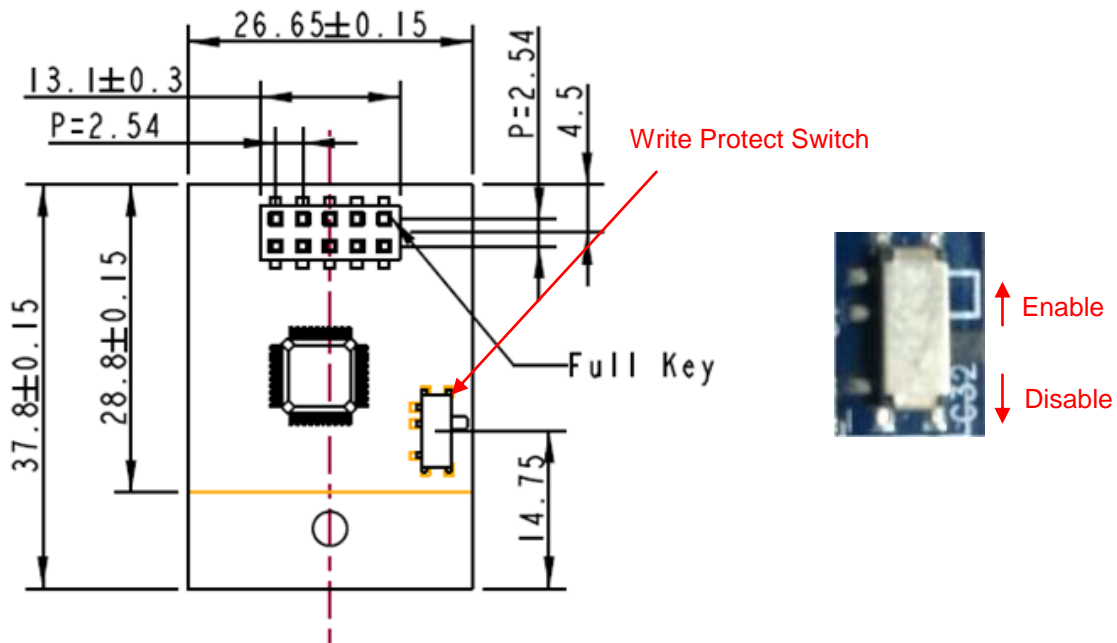

Unit: mm  
Tolerance:  $\pm 0.2$

## 7. Product Ordering Information

### 7.1 Product Code Designations

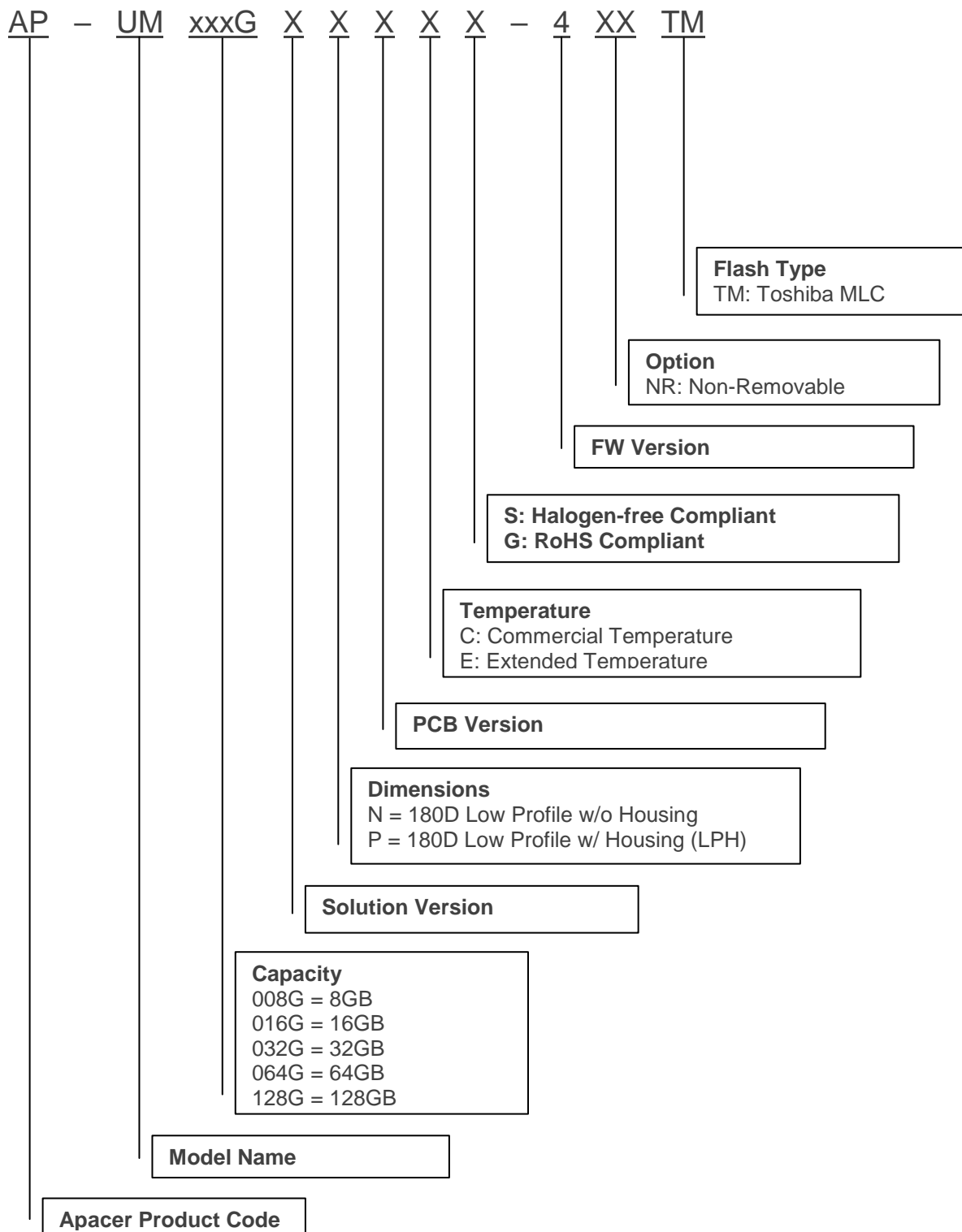

## 7.2 Valid Combinations

### 7.2.1 Low Profile 180 Degree

Capacity	Standard Temperature	Extended Temperature
8GB	AP-UM008GAN2CS-4TM	AP-UM008GAN2ES-4TM
16GB	AP-UM016GAN2CS-4TM	AP-UM016GAN2ES-4TM
32GB	AP-UM032GAN2CS-4TM	AP-UM032GAN2ES-4TM
64GB	AP-UM064GAN2CS-4TM	AP-UM064GAN2ES-4TM
128GB	AP-UM128GAN2CS-4TM	AP-UM128GAN2ES-4TM

### 7.2.2 LPH Low Profile 180 Degree

Capacity	Standard Temperature	Extended Temperature
8GB	AP-UM008GAP2CS-4TM	AP-UM008GAP2ES-4TM
16GB	AP-UM016GAP2CS-4TM	AP-UM016GAP2ES-4TM
32GB	AP-UM032GAP2CS-4TM	AP-UM032GAP2ES-4TM
64GB	AP-UM064GAP2CS-4TM	AP-UM064GAP2ES-4TM
128GB	AP-UM128GAP2CS-4TM	AP-UM128GAP2ES-4TM

**Note:** Valid combinations are those products in mass production or will be in mass production. Consult your Apacer sales representative to confirm availability of valid combinations and to determine availability of new combinations.

## Revision History

Revision	Description	Date
1.0	Official release	12/14/2017

## Global Presence

### Taiwan (Headquarters)

#### Apacer Technology Inc.

1F., No.32, Zhongcheng Rd., Tucheng Dist.,  
New Taipei City 236, Taiwan R.O.C.  
Tel: 886-2-2267-8000  
Fax: 886-2-2267-2261  
[amtsales@apacer.com](mailto:amtsales@apacer.com)

### U.S.A.

#### Apacer Memory America, Inc.

46732 Lakeview Blvd., Fremont, CA 94538  
Tel: 1-408-518-8699  
Fax: 1-510-249-9551  
[sa@apacerus.com](mailto:sa@apacerus.com)

### Japan

#### Apacer Technology Corp.

5F, Matsura Bldg., Shiba, Minato-Ku  
Tokyo, 105-0014, Japan  
Tel: 81-3-5419-2668  
Fax: 81-3-5419-0018  
[jpservices@apacer.com](mailto:jpservices@apacer.com)

### Europe

#### Apacer Technology B.V.

Science Park Eindhoven 5051 5692 EB Son,  
The Netherlands  
Tel: 31-40-267-0000  
Fax: 31-40-290-0686  
[sales@apacer.nl](mailto:sales@apacer.nl)

### China

#### Apacer Electronic (Shanghai) Co., Ltd

Room D, 22/FL, No.2, Lane 600, JieyunPlaza,  
Tianshan RD, Shanghai, 200051, China  
Tel: 86-21-6228-9939  
Fax: 86-21-6228-9936  
[sales@apacer.com.cn](mailto:sales@apacer.com.cn)

### India

#### Apacer Technologies Pvt Ltd,

Unit No.201, "Brigade Corner", 7<sup>th</sup> Block  
Jayanagar,  
Yediyur Circle, Bangalore – 560082, India  
Tel: 91-80-4152-9061  
Fax: 91-80-4170-0215  
[sales\\_india@apacer.com](mailto:sales_india@apacer.com)