

RoHS Recast Compliant **USB-Disk Module 2A-M** Industrial Product Specifications

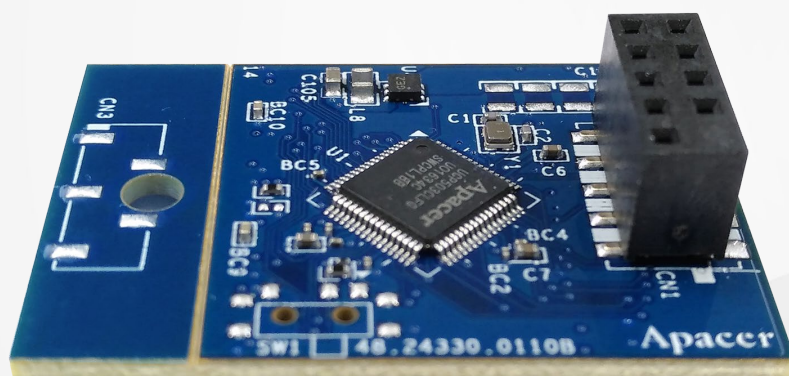

October 31, 2023

Version 1.8



Apacer Technology Inc.

1F, No.32, Zhongcheng Rd., Tucheng Dist., New Taipei City, Taiwan, R.O.C

Tel: +886-2-2267-8000 Fax: +886-2-2267-2261

www.apacer.com

Specifications Overview:

- **USB2.0 High-Speed and USB1.1 Full-Speed Compatible Interface**
- **Capacity**
 - 8, 16, 32, 64, 128 GB
- **Performance¹**
 - Sequential read: Up to 44 MB/sec
 - Sequential write: Up to 43 MB/sec
 - Random read (4K): Up to 2,300 IOPS
 - Random write (4K): Up to 190 IOPS
- **Flash Management**
 - Flash bad-block management
 - Global Wear Leveling
 - BCH (72 bit) Error Detection Code/Error Correction Code (EDC/ECC)
 - S.M.A.R.T.
 - Power Failure Management
- **Supports Non-Removable Setting**
- **NAND Flash Type: MLC**
- **MTBF: >1,000,000 hours**
- **Endurance (in Terabytes Written: TBW)**
 - 8 GB: 7 TBW
 - 16 GB: 18 TBW
 - 32 GB: 38 TBW
 - 64 GB: 51 TBW
 - 128 GB: 117 TBW
- **Temperature Range**
 - Operating:
 - Standard: 0°C to 70°C
 - Wide: -40°C to 85°C
 - Storage: -40°C to 100°C
- **Supports Boot-up Function for OS**
 - Windows: WinXP/7 or later
 - Mac: 10.2.8 or later
 - Linux: 2.4.10 or later
- **Power Consumption¹**
 - Operating voltage: 5V (with a certain percentage of tolerance)
 - Active mode (Max.): 125 mA
 - Idle mode: 50 mA
- **Connector**
 - 10-pin (2x5) female header in 2.54mm
- **Write Protect Switch (optional)**
- **RoHS Recast Compliant (2011/65/EU)**

Note:

1. Varies from capacities. The values for performances and power consumptions presented are typical and may vary depending on flash configurations or platform settings. The term idle refers to the standby state of the device.

Table of Contents

1. General Description	4
2. Functional Block	4
3. Pin Assignments.....	5
3.1 Type A, Type B, and Type C	5
3.2 Type D (STD)	6
4. Product Specifications.....	7
4.1 Capacity.....	7
4.2 Performance.....	7
4.3 Environmental Specifications	7
4.4 Mean Time Between Failures (MTBF).....	8
4.5 Certification and Compliance.....	8
4.6 Endurance	8
5. Flash Management	9
5.1 Performance-optimized Controller	9
5.2 Error Correction Code (ECC)	9
5.3 Flash Block Management	9
5.4 Global Wear Leveling	9
5.5 Power Failure Management.....	9
5.6 S.M.A.R.T.....	10
5.7 Write Protection Mode (optional).....	10
6. Electrical Specifications.....	11
6.1 Operating Conditions	11
6.2 Absolute Maximum Rating	11
6.3 Power Consumption.....	11
6.4 AC Characteristics	12
7. Mechanical Specifications.....	13
7.1 Horizontal Design	13
7.1.1 Type A (STD 90D)	13
7.1.2 Type B (STD 90D-MH)	14
7.1.3 Type C (STD 90D-MS)	15
7.2 Vertical Design.....	16

7.2.1 Type D (STD 180D)	16
7.3 Write Protect Switch (optional)	17

8. Product Ordering Information18

8.1 Product Code Designations	18
8.2 Valid Combinations	19
8.2.1 Type A (STD 90D) Standard 90 Degree	19
8.2.2 Type B (STD 90D-MH) Standard 90 Degree Mounting Header	19
8.2.3 Type C (STD 90D-MS) Standard 90 Degree Mounting Screw	19
8.2.4 Type D (STD 180D) Standard 180 Degree	19
8.2.5 Type A (STD 90D) NR Standard 90 Degree	20
8.2.6 Type B (STD 90D-MH) NR Standard 90 Degree Mounting Header	20
8.2.7 Type C (STD 90D-MS) NR Standard 90 Degree Mounting Screw	20
8.2.8 Type D (STD 180D) NR Standard 180 Degree	20

1. General Description

Apacer's USB-Disk Module (UDM) 2A-M is a high performance, highly reliable, high endurance USB2.0 flash disk module in a small form factor designed for embedded applications or the system as a boot drive. As an embedded flash storage, it is compliant with USB2.0 and backward compliant with USB1.1, and connects to the host system via a 10-pin connector.

2. Functional Block

The USB-Disk Module (UDM) contains a controller, embedded firmware, and Flash Media with a female connector. The UDM interfaces with the host system allowing data to be written to and read from the Flash Media.

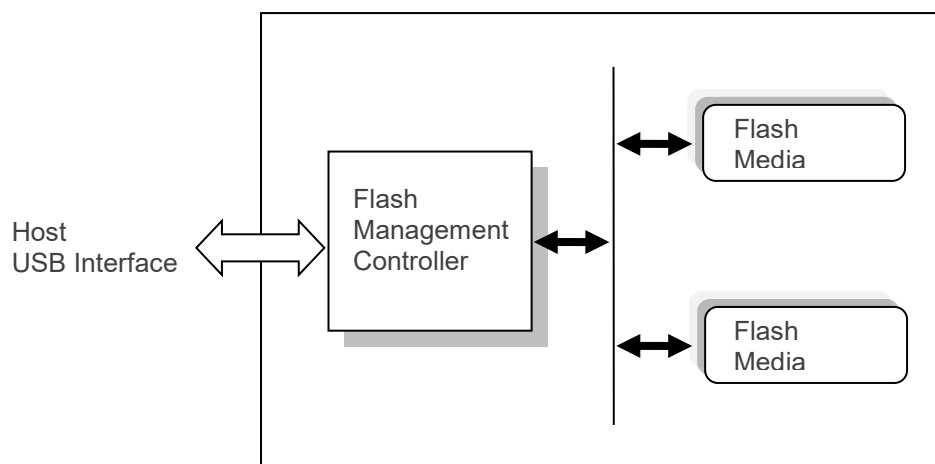

Figure 2-1 Functional Block Diagram

3. Pin Assignments

This chapter provides information on the pin assignments and signal descriptions.

3.1 Type A, Type B, and Type C

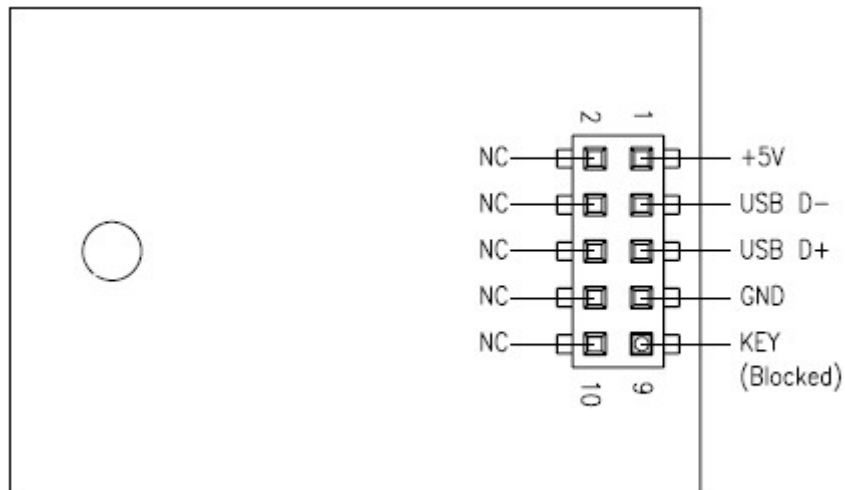

Table 3-1 Pin Assignment of the 10-Pin Configuration in Type A, Type B, and Type C

Pin	Signal	Pin	Signal
1	+5V	2	N.C
3	USB D-	4	N.C
5	USB D+	6	N.C
7	GND	8	N.C
9	Key (Blocked)	10	N.C

3.2 Type D (STD)

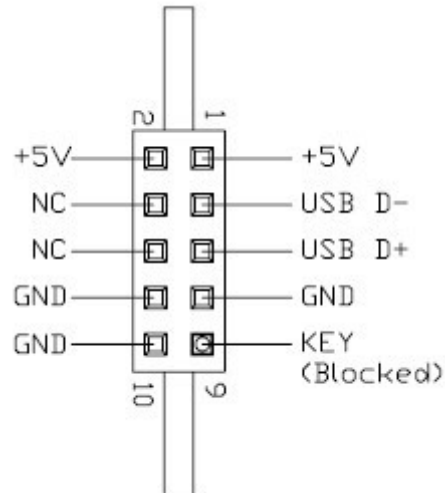

Table 3-2 Pin Assignment of the 10-Pin Configuration in Type D (STD)

Pin	Signal	Pin	Signal
1	+5V	2	+5V
3	USB D-	4	N.C
5	USB D+	6	N.C
7	GND	8	GND
9	Key (Blocked)	10	GND

4. Product Specifications

4.1 Capacity

The USB-Disk Module product family is available as shown in Table 4-1.

Table 4-1 Capacity Specifications

Capacity	Total Bytes
8 GB	8,002,748,416
16 GB	16,022,257,664
32 GB	32,010,944,512
64 GB	64,021,889,024
128 GB	128,043,745,280

Note: The number of total bytes may vary depending on the file system in use.

4.2 Performance

Performance of the USB-Disk Module product is listed below in Table 4-2.

Table 4-2 Performance Specifications

Performance	Capacity	8 GB	16 GB	32 GB	64 GB	128 GB
	Sequential Read (MB/s)		44	44	44	44
Sequential Write (MB/s)		26	42	42	42	43
4K Random Read (IOPS)		1,900	1,800	1,800	1,700	2,300
4K Random Write (IOPS)		100	115	95	190	35

Notes:

- Results may differ from various flash configurations or host system setting.
- Sequential performance is based on CrystalDiskMark 5.2.1 with file size 1,000MB.
- Random performance measured using IOMeter with Queue Depth 32.

4.3 Environmental Specifications

Environmental specification of the USB-Disk Module product family is available as shown in Table 4-3.

Table 4-3 Environmental Specifications

Parameter	Type	Specifications
Temperature	Operating	0°C to 70°C (Standard); -40°C to 85°C (Wide)
	Non-operating	-40°C to 100°C
Vibration	Operating	7.69 GRMS, 20~2000 Hz/random (compliant with MIL-STD-810G)
	Non-operating	4.02 GRMS, 15~2000 Hz/random (compliant with MIL-STD-810G)
Shock	Operating	Acceleration, 50(G)/11(ms)/half sine (compliant with MIL-STD-202G)
	Non-operating	Acceleration, 1500(G)/0.5(ms)/half sine (compliant with MIL-STD-883K)

Note: This Environmental Specification table indicates the conditions for testing the device. Real world usages may affect the results.

4.4 Mean Time Between Failures (MTBF)

Mean Time Between Failures (MTBF) is predicted based on reliability data for the individual components in Apacer’s USB flash drive. Serving as statistical reference, the prediction result for Apacer’s USB is more than 1,000,000 hours.

Note: The MTBF is predicated and calculated based on “Telcordia Technologies Special Report, SR-332, Issue 3” method.

4.5 Certification and Compliance

The USB-Disk Module (UDM) complies with the following standards:

- CE
- UKCA
- FCC
- RoHS Recast
- MIL-STD-810G

4.6 Endurance

The endurance of a storage device is predicted by TeraBytes Written based on several factors related to usage, such as the amount of data written into the drive, block management conditions, and daily workload for the drive. Thus, key factors, such as Write Amplifications and the number of P/E cycles, can influence the lifespan of the drive.

Table 4-4 Endurance Specifications

Capacity	TeraBytes Written
8 GB	7
16 GB	18
32 GB	38
64 GB	51
128 GB	117

Notes:

- The estimated values are based on sequential write behavior. (Apacer EDTest Tool, test mode – sequential data pattern – 100.00% of disk space)
- Flash vendor guaranteed MLC P/E cycle: Toshiba - 3K.
- The WLE/WAF values may vary with the real application on user platform.
- 1 Terabyte = 1,000 GB.

5. Flash Management

5.1 Performance-optimized Controller

The heart of an UDM is the USB controller, which translates standard USB signals into the data and controls of the flash media. This proprietary USB controller is specifically designed to attain high data throughput from host to flash.

5.2 Error Correction Code (ECC)

The UDM uses BCH Error Detection Code (EDC) and Error Correction Code (ECC) algorithms which correct up to 72bit random single-bit errors for each 1024-byte block of data depending on spare area of flash memory. High performance is achieved through hardware-based error detection and correction.

5.3 Flash Block Management

Current production technology is unable to guarantee total reliability of NAND flash memory array. When a flash memory device leaves factory, it comes with a minimal number of initial bad blocks during production or out-of-factory as there is no currently known technology that produce flash chips free of bad blocks. In addition, bad blocks may develop during program/erase cycles. Since bad blocks are inevitable, the solution is to keep them in control. Apacer flash devices are programmed with ECC and block mapping technique to reduce invalidity or error. Once bad blocks are detected, data in those blocks will be transferred to free blocks and error will be corrected by designated algorithms.

5.4 Global Wear Leveling

Flash memory can be erased a limited number of times, This number is called the erase cycle limit, or write endurance limit, The erase cycle limit applies to each individual erase block in the flash device.

In a typical application, and especially if a file system is used, specific pages are constantly updated (e.g., the page that contains the FAT, registry, etc.). Without any special handling, these pages would wear out more rapidly than other pages, reducing the lifetime of the entire flash.

To overcome this inherent deficiency, Apacer's USB-Disk Module (UDM) uses Global Wear Leveling algorithm. This algorithm ensures that consecutive writes of a specific sector are not written physically to the same page in the flash. This spreads flash media usage evenly across all pages, thereby maximizing flash lifetime.

The Global Wear Leveling mechanism provides write/erase cycles for reliable data storage over an extended period.

5.5 Power Failure Management

Power Failure Management plays a crucial role when power supply becomes unstable. Power disruption may occur when users are storing data into the SSD, leading to instability in the drive. However, with Power Failure Management, a firmware protection mechanism will be activated to scan pages and blocks once power is resumed. Valid data will be transferred to new blocks for merging and the mapping table will be rebuilt. Therefore, data reliability can be reinforced, preventing damage to data stored in the NAND Flash.

5.6 S.M.A.R.T.

S.M.A.R.T. is an abbreviation for Self-Monitoring, Analysis and Reporting Technology, a self-monitoring system that provides indicators of drive health as well as potential disk problems. It serves as a warning for users from unscheduled downtime by monitoring and displaying critical drive information. Ideally, this should allow taking proactive actions to prevent drive failure and make use of S.M.A.R.T. information for future product development reference.

Table 5-1 SMART Attribute ID List

ID (Hex)	Attribute Name
162 (0xA2)	Spare Block Count
163 (0xA3)	Maximum Erase Count
164 (0xA4)	Average Erase Count
166 (0xA6)	Total Later Bad Block Count
167 (0xA7)	Protect Mode

5.7 Write Protection Mode (optional)

When the device is configured to the Write-Protection mode, it enhances the data security and protection. This feature prevents the stored data from inadvertent system writes or erases, and viruses.

6. Electrical Specifications

6.1 Operating Conditions

Table 6-1 lists the absolute stress rating for the USB-Disk Module.

Caution: Absolute Maximum Stress Ratings – Applied conditions greater than those listed under “Absolute Maximum Stress Ratings” may cause permanent damage to the device. This is a stress rating only and functional operation of the device at these conditions or conditions greater than those defined in the operational sections of this data sheet is not implied. Exposure to absolute maximum stress rating conditions may affect device reliability.

Table 6-1 Operating Range

Range	Ambient Temperature	Voltage
Standard Temperature	0°C to 70°C	4.5-5.5V
Wide Temperature	-40°C to 85°C	

6.2 Absolute Maximum Rating

Table 6-2 lists the absolute maximum power ratings for the USB-Disk Module.

Table 6-2 Absolute maximum power pin stress ratings

Parameter	Symbol	Min	Max	Unit
Power Supply Input	VDD- VSS	-0.3	5.5	V
Voltage on any pin except VDD with respect to GND	VIN	-ss - 0.3	VDD +0.3	V

6.3 Power Consumption

Table 6-3 lists the power consumption for the USB-Disk Module.

Table 6-3 Power Consumption

Mode	Capacity					
	Unit	8 GB	16 GB	32 GB	64 GB	128 GB
Active (Max.)	mA	85	110	110	120	125
Idle		47	49	49	50	50

Notes:

- All values are typical and may vary depending on flash configurations or host system settings.
- Power consumption is measured using CrystalDiskMark 5.2.1 with file size 1,000MB

6.4 AC Characteristics

Table 6-4 AC Characteristics Full Speed

Parameter	Symbol	Min	Typ	Max	Unit
Rise Time	T_{FR}	4	—	20	ns
Fall Time	T_{FF}	4	—	20	ns
Differential Rise and Fall Time Matching	T_{FRFM}	90		111.11	%
Driver Output Resistance	Z_{DRV}	28	—	44	Ω

Table 6-5 AC Characteristics High Speed

Parameter	Symbol	Min	Typ	Max	Unit
Rise Time (10%~90%)	T_{HSR}	500	—	—	ps
Fall Time (10%~90%)	T_{HSF}	500	—	—	ps
Driver Output Resistance	Z_{HSDRV}	40.5	—	49.5	Ω

7. Mechanical Specifications

7.1 Horizontal Design

7.1.1 Type A (STD 90D)

Standard 90 Degree

Table 7-1 Type A Dimensions

Parameter	Unit	8 GB	16 GB	32 GB	64 GB	128 GB
Length	mm	28.8 ± 0.15				
Width		26.65 ± 0.15				
Height (Max.)		10.76				

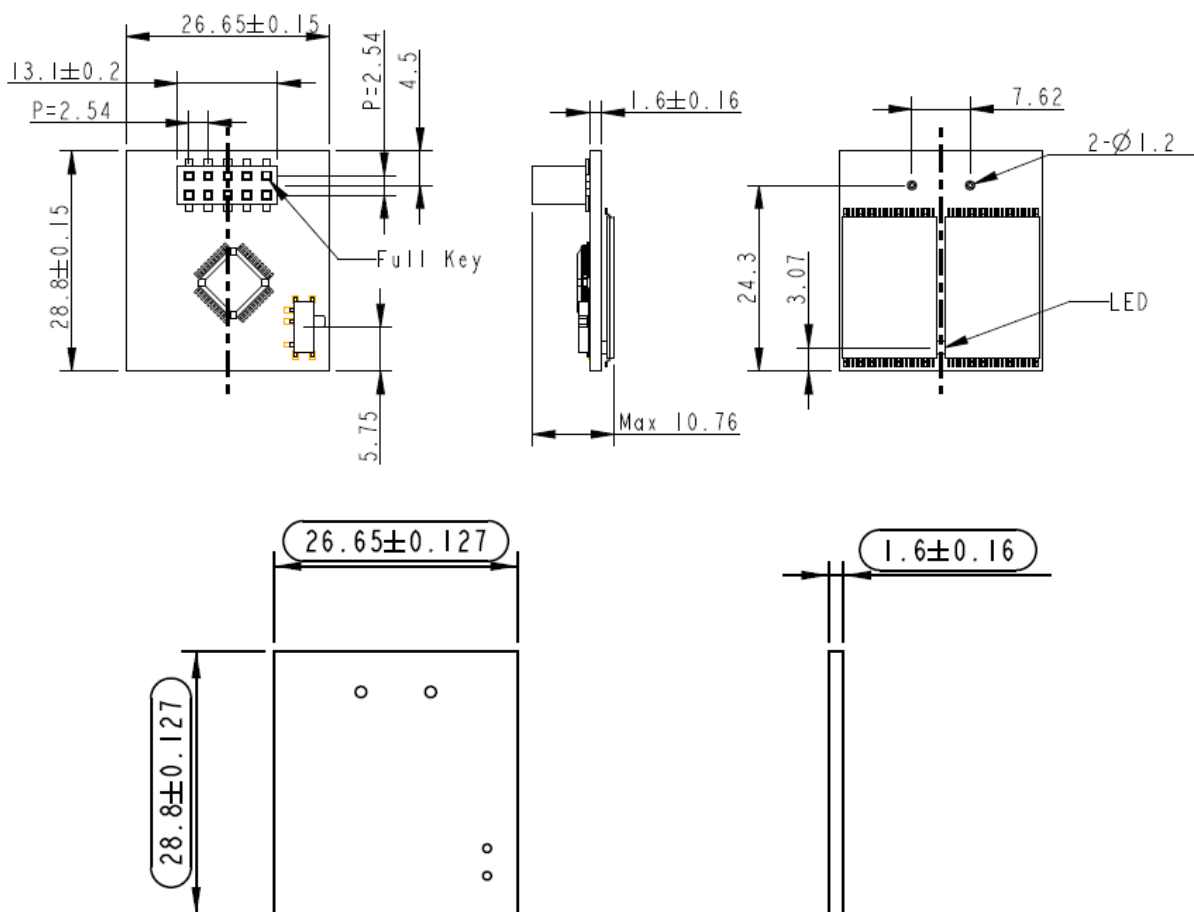

Figure 7-1 Type A Dimensions

7.1.2 Type B (STD 90D-MH)

Standard 90 Degree Mounting Header

Table 7-2 Type B Dimensions

Parameter	Unit	8 GB	16 GB	32 GB	64 GB	128 GB
Length	mm	37.8 ± 0.15				
Width		26.65 ± 0.15				
Height (Max.)		10.76				

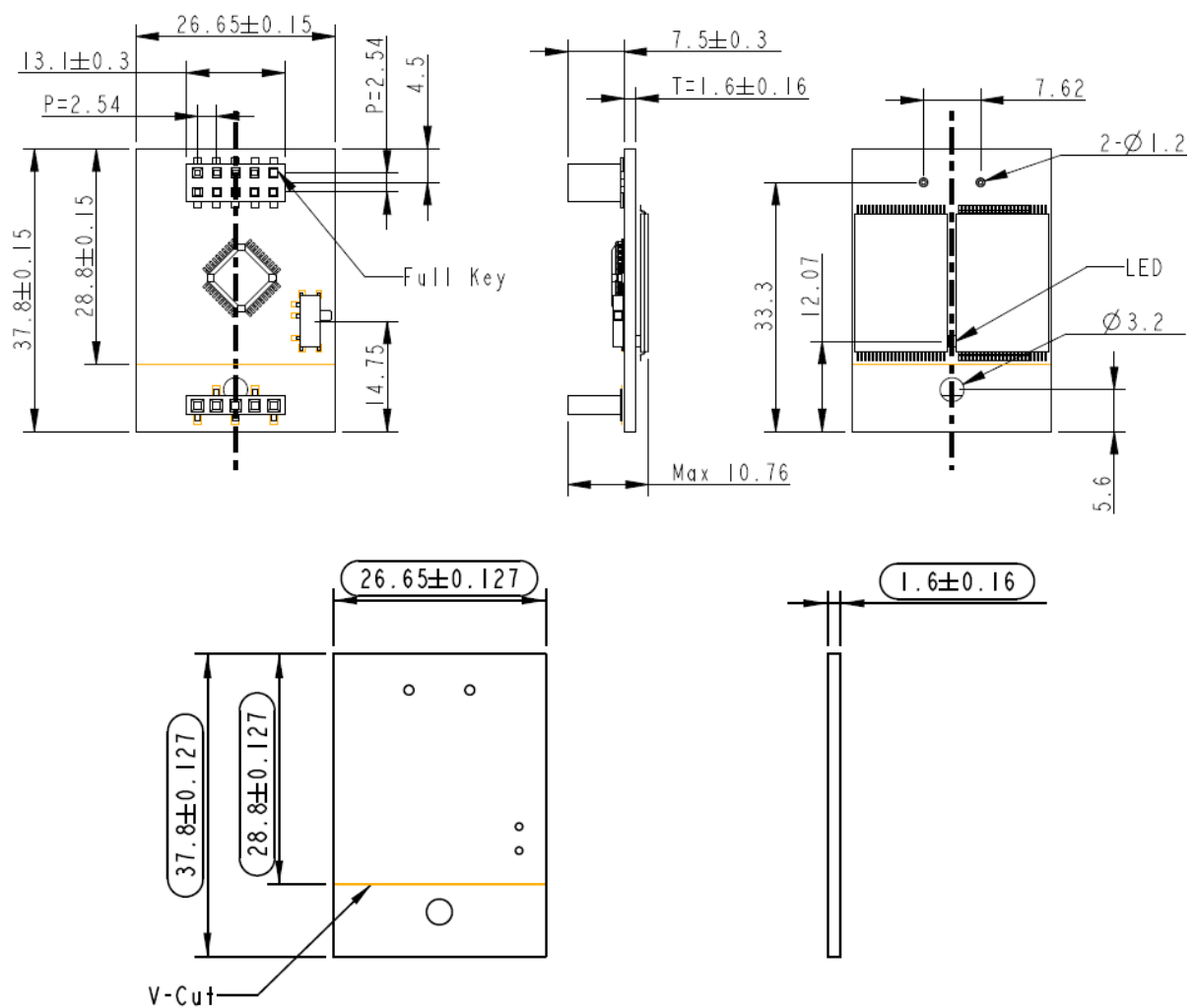

Figure 7-2 Type B Dimensions

7.1.3 Type C (STD 90D-MS)

Standard 90 Degree Mounting Screw

Table 7-3 Type C Dimensions

Parameter	Unit	8 GB	16 GB	32 GB	64 GB	128 GB
Length	mm	37.80 ± 0.15				
Width		26.65 ± 0.15				
Height (Max.)		10.76				

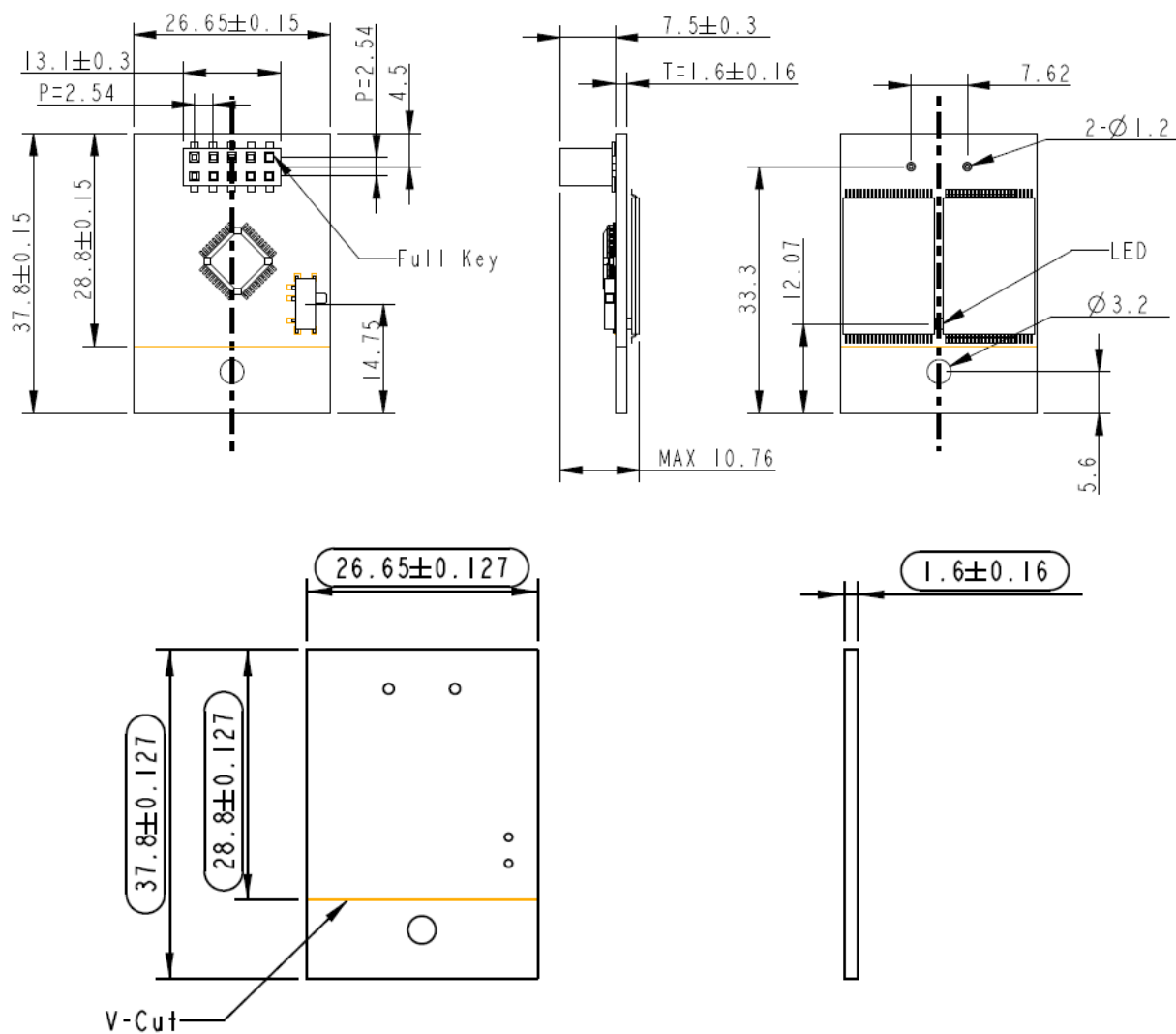

Figure 7-3 Type C Dimensions

7.2 Vertical Design

7.2.1 Type D (STD 180D)

Standard 180 Degree

Table 7-4 Type D Dimensions

Parameter	Unit	8 GB	16 GB	32 GB	64 GB	128 GB
Length	mm	36.8 ± 0.35				
Width		26.65 ± 0.15				
Height		5.00 ± 0.2				

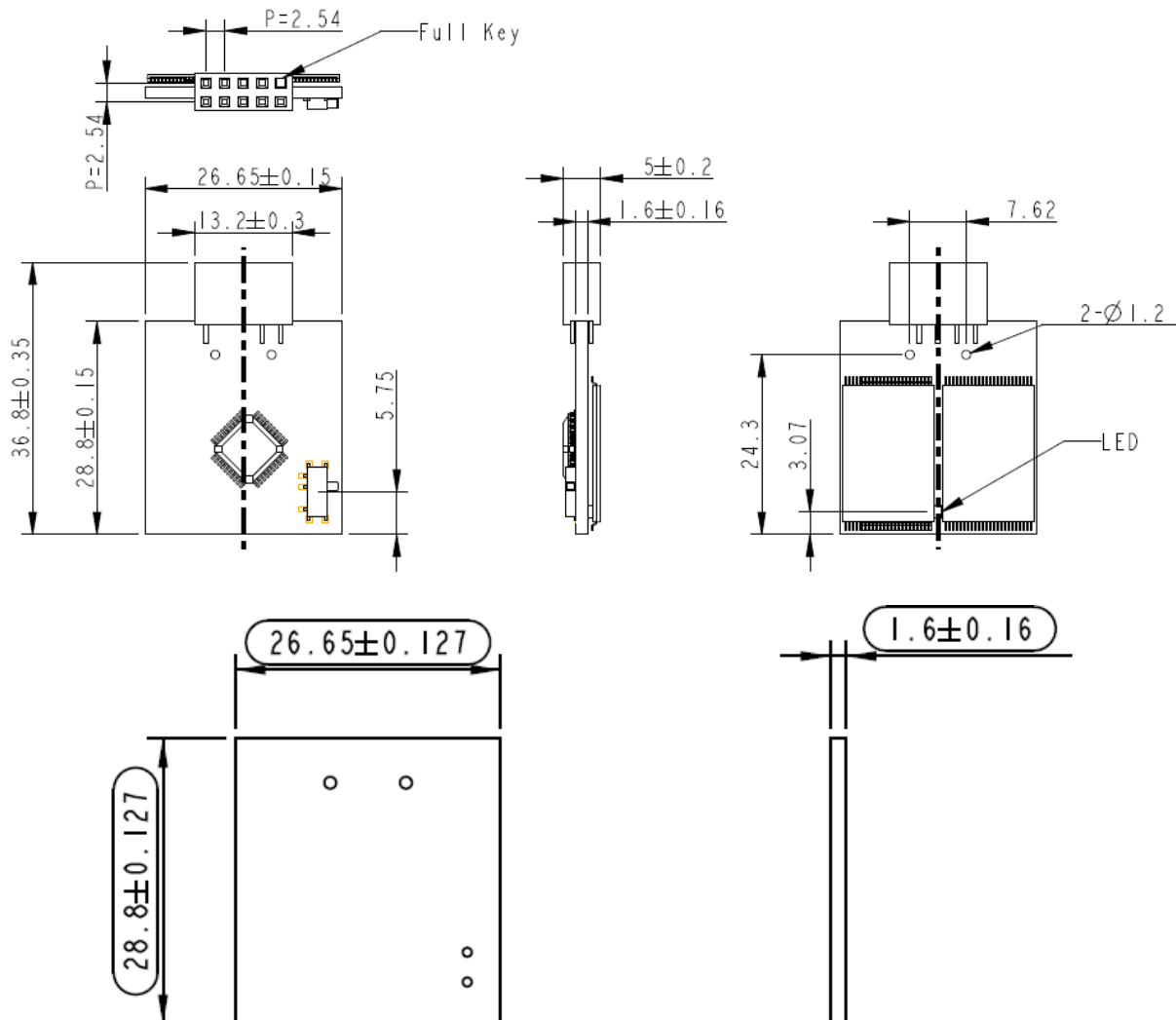

Figure 7-4 Type D Dimensions

7.3 Write Protect Switch (optional)

Apacer implements the Virtual Write scheme that allows write commands to go through the flash controller and data temporarily stored, but no data has been actually written into the flash. Once the system is reset and rebooted, the temporarily stored data will be lost and nowhere to be found in the system. Since the Virtual Write scheme runs at device level, it requires no software or driver installation and is independent from the host OS.

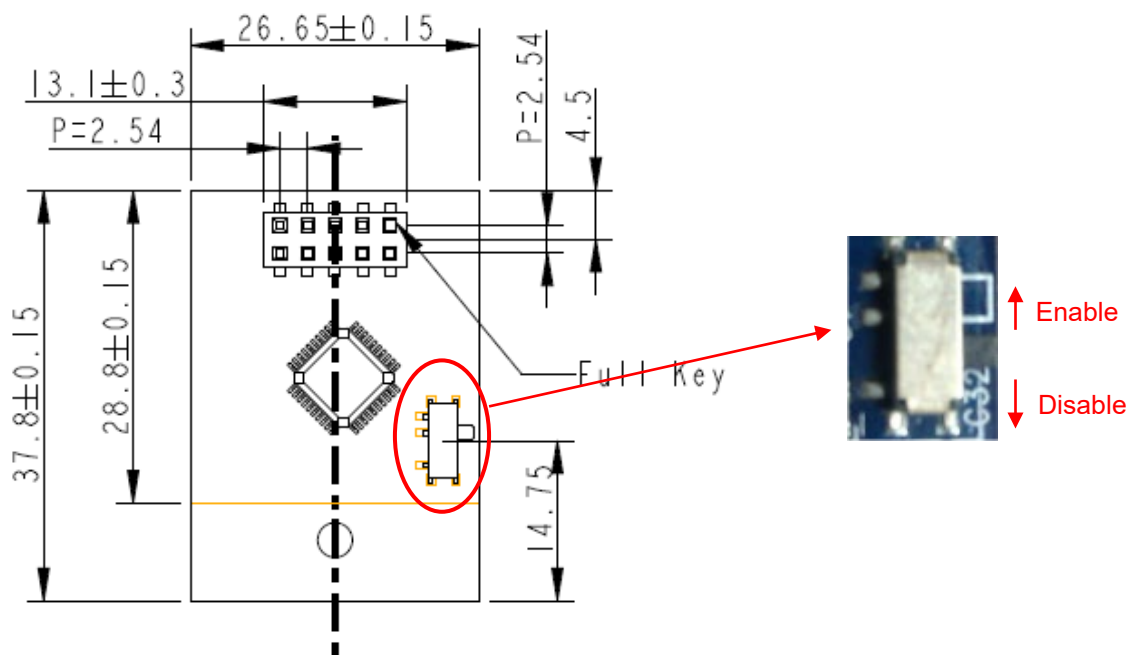
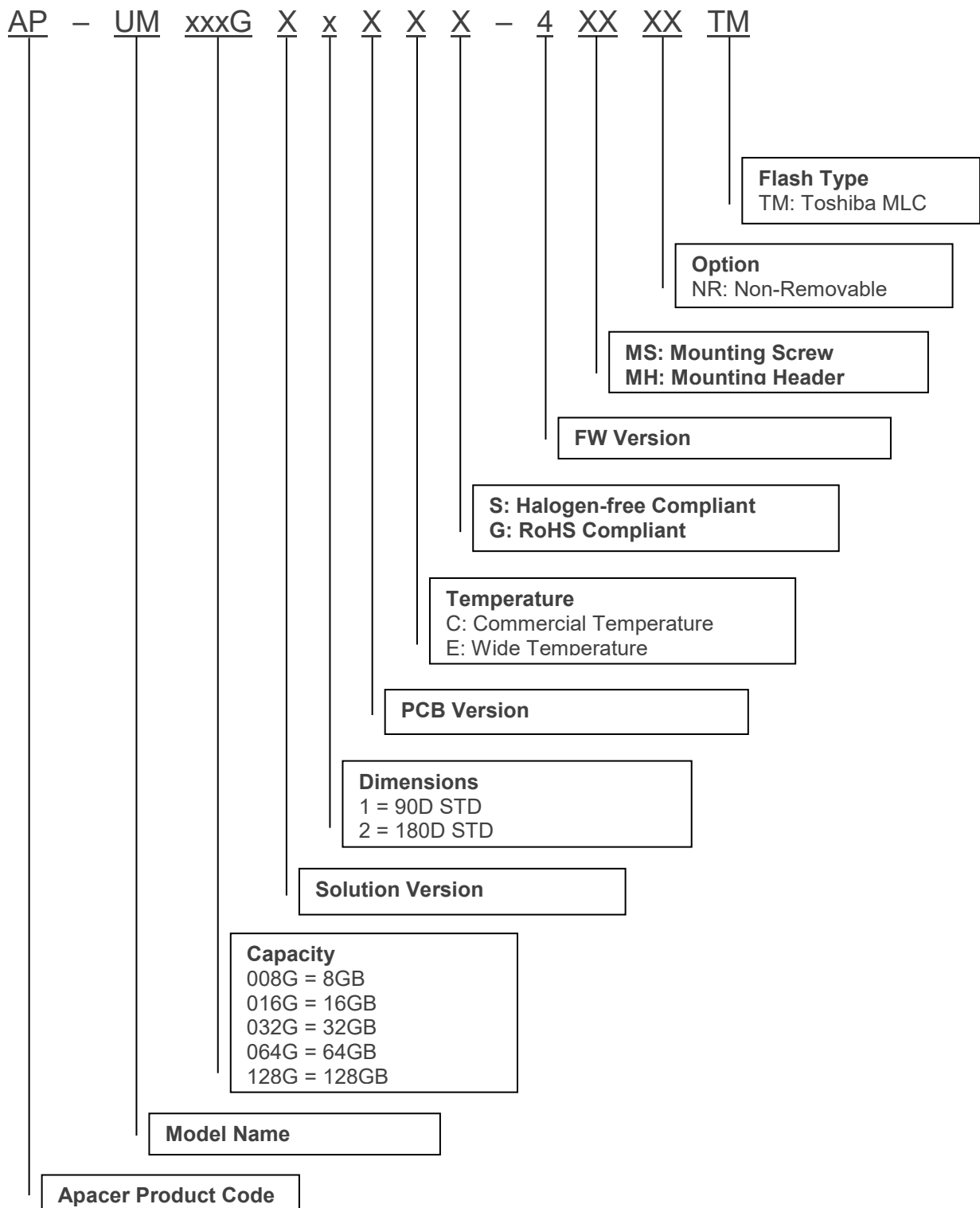

Figure 7-5 Write Protect Switch

8. Product Ordering Information

8.1 Product Code Designations



8.2 Valid Combinations

The following tables list the available models of the USB-Disk Module series which are in mass production or will be in mass production. Consult your Apacer sales representative to confirm availability of valid combinations and to determine availability of new combinations.

8.2.1 Type A (STD 90D) Standard 90 Degree

Capacity	Standard Temperature	Wide Temperature
8GB	AP-UM008GA11CS-4TM	AP-UM008GA11ES-4TM
16GB	AP-UM016GA11CS-4TM	AP-UM016GA11ES-4TM
32GB	AP-UM032GA11CS-4TM	AP-UM032GA11ES-4TM
64GB	AP-UM064GA11CS-4TM	AP-UM064GA11ES-4TM
128GB	AP-UM128GA11CS-4TM	AP-UM128GA11ES-4TM

8.2.2 Type B (STD 90D-MH) Standard 90 Degree Mounting Header

Capacity	Standard Temperature	Wide Temperature
8GB	AP-UM008GA11CS-4MHTM	AP-UM008GA11ES-4MHTM
16GB	AP-UM016GA11CS-4MHTM	AP-UM016GA11ES-4MHTM
32GB	AP-UM032GA11CS-4MHTM	AP-UM032GA11ES-4MHTM
64GB	AP-UM064GA11CS-4MHTM	AP-UM064GA11ES-4MHTM
128GB	AP-UM128GA11CS-4MHTM	AP-UM128GA11ES-4MHTM

8.2.3 Type C (STD 90D-MS) Standard 90 Degree Mounting Screw

Capacity	Standard Temperature	Wide Temperature
8GB	AP-UM008GA11CS-4MSTM	AP-UM008GA11ES-4MSTM
16GB	AP-UM016GA11CS-4MSTM	AP-UM016GA11ES-4MSTM
32GB	AP-UM032GA11CS-4MSTM	AP-UM032GA11ES-4MSTM
64GB	AP-UM064GA11CS-4MSTM	AP-UM064GA11ES-4MSTM
128GB	AP-UM128GA11CS-4MSTM	AP-UM128GA11ES-4MSTM

8.2.4 Type D (STD 180D) Standard 180 Degree

Capacity	Standard Temperature	Wide Temperature
8GB	AP-UM008GA21CS-4TM	AP-UM008GA21ES-4TM
16GB	AP-UM016GA21CS-4TM	AP-UM016GA21ES-4TM
32GB	AP-UM032GA21CS-4TM	AP-UM032GA21ES-4TM
64GB	AP-UM064GA21CS-4TM	AP-UM064GA21ES-4TM
128GB	AP-UM128GA21CS-4TM	AP-UM128GA21ES-4TM

8.2.5 Type A (STD 90D) NR Standard 90 Degree

Capacity	Standard Temperature	Wide Temperature
8GB	AP-UM008GA11CS-4NRTM	AP-UM008GA11ES-4NRTM
16GB	AP-UM016GA11CS-4NRTM	AP-UM016GA11ES-4NRTM
32GB	AP-UM032GA11CS-4NRTM	AP-UM032GA11ES-4NRTM
64GB	AP-UM064GA11CS-4NRTM	AP-UM064GA11ES-4NRTM
128GB	AP-UM128GA11CS-4NRTM	AP-UM128GA11ES-4NRTM

8.2.6 Type B (STD 90D-MH) NR Standard 90 Degree Mounting Header

Capacity	Standard Temperature	Wide Temperature
8GB	AP-UM008GA11CS-4MHNRTM	AP-UM008GA11ES-4MHNRTM
16GB	AP-UM016GA11CS-4MHNRTM	AP-UM016GA11ES-4MHNRTM
32GB	AP-UM032GA11CS-4MHNRTM	AP-UM032GA11ES-4MHNRTM
64GB	AP-UM064GA11CS-4MHNRTM	AP-UM064GA11ES-4MHNRTM
128GB	AP-UM128GA11CS-4MHNRTM	AP-UM128GA11ES-4MHNRTM

8.2.7 Type C (STD 90D-MS) NR Standard 90 Degree Mounting Screw

Capacity	Standard Temperature	Wide Temperature
8GB	AP-UM008GA11CS-4MSNRTM	AP-UM008GA11ES-4MSNRTM
16GB	AP-UM016GA11CS-4MSNRTM	AP-UM016GA11ES-4MSNRTM
32GB	AP-UM032GA11CS-4MSNRTM	AP-UM032GA11ES-4MSNRTM
64GB	AP-UM064GA11CS-4MSNRTM	AP-UM064GA11ES-4MSNRTM
128GB	AP-UM128GA11CS-4MSNRTM	AP-UM128GA11ES-4MSNRTM

8.2.8 Type D (STD 180D) NR Standard 180 Degree

Capacity	Standard Temperature	Wide Temperature
8GB	AP-UM008GA21CS-4NRTM	AP-UM008GA21ES-4NRTM
16GB	AP-UM016GA21CS-4NRTM	AP-UM016GA21ES-4NRTM
32GB	AP-UM032GA21CS-4NRTM	AP-UM032GA21ES-4NRTM
64GB	AP-UM064GA21CS-4NRTM	AP-UM064GA21ES-4NRTM
128GB	AP-UM128GA21CS-4NRTM	AP-UM128GA21ES-4NRTM

Revision History

Revision	Description	Date
0.1	Preliminary release	4/6/2017
1.0	Official release	8/4/2017
1.1	- Removed Extended Data Protection and added Write Protect Switch (optional) on Features page - Added 6.3 Write Protect Switch (optional)	11/15/2017
1.2	- Updated 1. General Descriptions - Added 1.1.2 Flash Block Management, 1.1.4 S.M.A.R.T. and 1.1.5 Power Failure Management - Added 4.6 Endurance	1/18/2018
1.3	Revised connector size from 2.45mm to 2.54mm at Connector on Specifications Overview page	8/15/2018
1.4	Revised valid combinations for 7.2.8 section	10/18/2018
1.5	- Renamed extended temperature to wide temperature - Updated the description of 1.1.2 Bad Block Management and 1.1.5 Power Failure Management - Updated Table 4-3 by changing storage temperature from -40°C to 85°C to -40°C to 100°C	8/14/2020
1.6	Updated mechanical specs for all types of models at 6. Physical Dimensions	10/22/2020
1.7	- Updated Table 4-3 by changing compliance standard for non-operating shock specification and adding UKCA - Added UKCA to 4.5 Certification and Compliance - Added 5.3 Flash Block Management and 5.6 S.M.A.R.T.	12/22/2022
1.8	Added "NR" to 8.2.8 Type D (STD 180D) Standard 180 Degree	10/31/2023

Global Presence

Taiwan (Headquarters)

Apacer Technology Inc.

1F., No.32, Zhongcheng Rd., Tucheng Dist.,
New Taipei City 236, Taiwan R.O.C.
Tel: 886-2-2267-8000
Fax: 886-2-2267-2261
amtsales@apacer.com

U.S.A.

Apacer Memory America, Inc.

46732 Lakeview Blvd., Fremont, CA 94538
Tel: 1-408-518-8699
Fax: 1-510-249-9551
sa@apacerus.com

Japan

Apacer Technology Corp.

6F, Daiyontamachi Bldg., 2-17-12, Shibaura, Minato-Ku,
Tokyo, 108-0023, Japan
Tel: 81-3-5419-2668
Fax: 81-3-5419-0018
jpservices@apacer.com

Europe

Apacer Technology B.V.

Science Park Eindhoven 5051 5692 EB Son,
The Netherlands
Tel: 31-40-267-0000
Fax: 31-40-290-0686
sales@apacer.nl

China

Apacer Electronic (Shanghai) Co., Ltd

Room D, 22/FL, No.2, Lane 600, JieyunPlaza,
Tianshan RD, Shanghai, 200051, China
Tel: 86-21-6228-9939
Fax: 86-21-6228-9936
sales@apacer.com.cn

India

Apacer Technologies Pvt Ltd,

1874, South End C Cross, 9th Block Jayanagar,
Bangalore-560069, India
Tel: 91-80-4152-9061/62
Fax: 91-80-4170-0215
sales_india@apacer.com