

RoHS Compliant

USB-Disk Module II Plus

Low-Profile 180D Product Specifications

September 3rd, 2014

Version 1.0



Apacer Technology Inc.

4th Fl., 75 Hsin Tai Wu Rd., Sec.1, Hsichih, New Taipei City, Taiwan 221

Tel: +886-2-2698-2888 Fax: +886-2-2698-2889

www.apacer.com

FEATURES:

- **USB2.0 High-Speed and USB1.1 Full-Speed compatible interface**
- **Capacity**
 - 4, 8, 16, 32, 64 GB
- **Performance***
 - Sustained read: 33 MB/s
 - Sustained write: 16 MB/s
- **Intelligent USB Module**
 - Advanced wear-leveling algorithms to substantially increase longevity of flash media
 - BCH (24 bit) Error Detection Code/Error Correction Code (EDC/ECC)
- **NAND Flash Type: MLC**
- **Write Protect (optional)**
- **MTBF**
 - Approximately greater than 3.29×10^6 hours
- **Support boot-up function for OS**
 - Windows XP Embedded
 - Windows CE
 - Linux
 - Windows 7
- **Temperature ranges**
 - 0°C to 70°C for operation (standard)
 - -40°C to 85°C for operation (extended)
 - -40°C to 85°C for storage
- **Power consumption (typical)***
 - Active mode: 165 mA
 - Sleep mode: 450 μ A
 - Operating voltage: 5V (with a certain percentage of tolerance)
- **Connector**
 - 10-pin (2x5) female header
- **RoHS Compliant**

*The values addressed in Performance and Power consumption are typical and may vary depending on settings and platforms.

TABLE OF CONTENTS

1. General Description	3
1.1 Performance-optimized Controller	3
1.1.1 Error Correction Code (ECC)	3
1.1.2 Wear-Leveling	3
1.1.3 Write Protection Mode (Optional)	3
2. Functional Block Diagram.....	4
3. Pin Assignment.....	5
3.1 Without Housing	5
3.2 With Housing	6
4. Performance & Reliability Specifications	7
4.1 Capacity Specifications	7
4.2 Performance Specifications.....	7
4.3 Environmental Specifications	7
4.4 MTBF	8
5. Electrical Specification	9
5.1 AC Characteristics	9
6. Mechanical Specifications.....	10
6.1 Without Housing	10
6.2 With Housing	11
7. Product Ordering Information.....	12
7.1 Product Code Designation	12
7.2 Valid Combinations	13

1. General Description

Apacer's USB-Disk Module (UDM) is a high performance, embedded solid state drive (SSD) designed to replace a conventional IDE hard disk drive. UDM SSD can be plugged into a standard Embedded USB connector commonly found in desktops, portable PC systems and industrial PC systems. This product is well suited for embedded flash storage applications offering new and expanded functionality as well as more cost-effective designs, better performance and increased reliability.

This UDM solid state drive is resistant to shock and vibration and compatible with widely used operating systems such as Windows CE, Windows XP Embedded, and Linux. In terms of suitability, it comes in various dimensions to multiple embedded usages.

1.1 Performance-optimized Controller

The heart of an UDM is the USB controller, which translates standard USB signals into the data and controls of the flash media. This proprietary USB controller is specifically designed to attain high data throughput from host to flash.

1.1.1 Error Correction Code (ECC)

The UDM uses BCH Error Detection Code (EDC) and Error Correction Code (ECC) algorithms which correct up to 24 random single-bit errors for each 1024-byte block of data depending on spare area of flash memory. High performance is achieved through hardware-based error detection and correction.

1.1.2 Wear-Leveling

Flash memory can be erased a limited number of times, This number is called the erase cycle limit, or write endurance limit, The erase cycle limit applies to each individual erase block in the flash device.

In a typical application, and especially if a file system is used, specific pages are constantly updated (e.g., the page that contains the FAT, registry, etc.). Without any special handling, these pages would wear out more rapidly than other pages, reducing the lifetime of the entire flash.

To overcome this inherent deficiency, Apacer's USB-Disk Module (UDM) uses wear-leveling algorithm. This wear-leveling algorithm ensures that consecutive writes of a specific sector are not written physically to the same page in the flash. This spreads flash media usage evenly across all pages, thereby maximizing flash lifetime.

The wear-leveling mechanism provides write/erase cycles for reliable data storage over an extended period.

1.1.3 Write Protection Mode (Optional)

When the device is configured to the Write-Protection mode, it enhances the data security and protection. This feature prevents the stored data from inadvertent system writes or erases, and viruses.

2. Functional Block Diagram

The USB-Disk Module (UDM) contains a controller, embedded firmware, and Flash Media with a female connector. The UDM interfaces with the host system allowing data to be written to and read from the Flash Media.

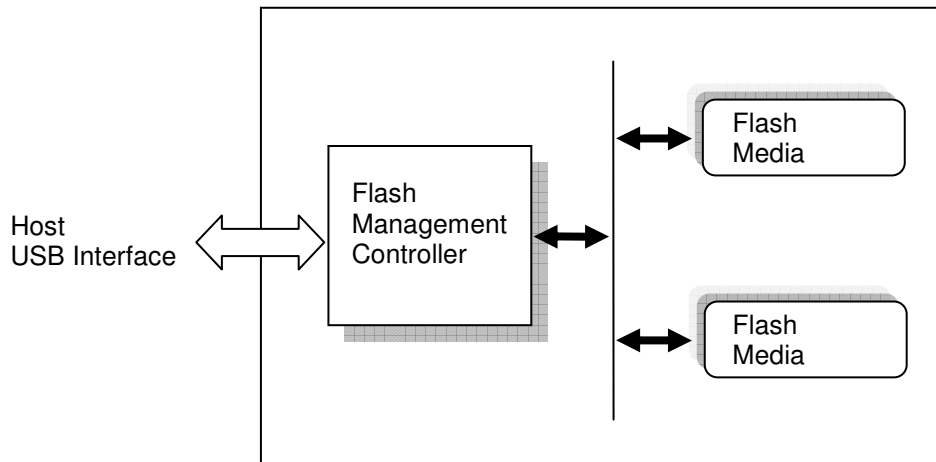

Figure 2-1: Functional block diagram

3. Pin Assignment

This chapter provides the information on the pin assignments and signal descriptions.

3.1 Without Housing

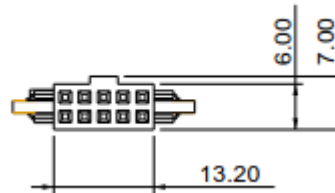

Table 3-1: Pin Assignment of the 10-pin configuration

Pin	Signal	Pin	Signal
1	+5V	2	N.C
3	USB D-	4	N.C
5	USB D+	6	N.C
7	GND	8	N.C
9	Key (Blocked)	10	N.C

3.2 With Housing



Table 3-2: Pin Assignment of the 10-pin configuration

Pin	Signal	Pin	Signal
1	+5V	2	+5V
3	USB D-	4	N.C
5	USB D+	6	N.C
7	GND	8	GND
9	Key (Blocked)	10	GND

4. Performance & Reliability Specifications

4.1 Capacity Specifications

The USB-Disk Module product family is available as below table matrix.

Table 4-1: Capacity Specification

Density	Total Bytes
4GB	4,001,382,400
8GB	8,011,153,408
16GB	16,030,662,656
32GB	32,061,325,312
64GB	64,139,362,304

Note: total user bytes may vary depending on file system in use.

4.2 Performance Specifications

Table 4-2: Performance Specifications

Capacity	4 GB	8 GB	16 GB	32 GB	64 GB
Performance					
Sustained read (MB/s)	32	32	33	33	33
Sustained write (MB/s)	10	10	14	16	16

Note: results may vary depending on flash configurations or host system settings

4.3 Environmental Specifications

Environmental specification of the USB-Disk Module (UDM) product family which follows the MIL-STD-810F standards is available as shown in Table 4-3.

Table 4-3: Environmental Specifications

Temperature	Operation	0°C to 70°C (Std.); -40°C to 85°C (Ext. Temp.)
	Storage	-40°C to 100°C
Vibration	Sine wave 10 Hz to 500 Hz, 50 m/s ² , 3 axes (IEC 68-2-6, non-operating)	
Shock	Half sine wave 50G, 6 axes, 18 times (IEC 68-2-27, non-operating)	
EMC	FCC, CE	

4.4 MTBF

Mean Time Between Failures (MTBF) is predicted based on reliability data for the individual components in this device. The measurement assumes that device failure rate can be generated by the sum of failure rates in each component and a steady state failure rate can be predicated as equal to or greater than 3.29×10^6 hours.

Notes about the MTBF:

The MTBF is predicated and calculated based on "Bellcore Analysis Method 1".

$$\lambda_{SS} = \pi_E \sum_{i=1}^m (Ni \lambda_{SSi})$$

m : number of component types

λ_{SS} : device failure rate at steady state

Ni : quantity of i type component

λ_{SSi} : failure rate for i type component at steady state

π_E : device environment factor

5. Electrical Specification

Caution: Absolute Maximum Stress Ratings – Applied conditions greater than those listed under “Absolute Maximum Stress Ratings” may cause permanent damage to the device. This is a stress rating only and functional operation of the device at these conditions or conditions greater than those defined in the operational sections of this data sheet is not implied. Exposure to absolute maximum stress rating conditions may affect device reliability.

Table 5-1: Operating Range

Range	Ambient Temperature	Voltage
Standard	0°C to 70°C	4.5-5.5V

Table 5-2: Absolute maximum power pin stress ratings

Parameter	Symbol	Min	Max	Unit
Power Supply Input	VDD- VSS	-0.3	5.5	V
Voltage on any pin except VDD with respect to GND	VIN	–ss – 0.3	VDD +0.3	V

5.1 AC Characteristics

Table 5-3: AC Characteristics Full Speed

Parameter	Symbol	Min	Typ	Max	Unit
Rise Time	T _{FR}	4	—	20	ns
Fall Time	T _{FF}	4	—	20	ns
Differential Rise and Fall Time Matching	T _{FRFM}	90	—	111.11	%
Driver Output Resistance	Z _{DRV}	28	—	44	Ω

Table 5-4: AC Characteristics High Speed

Parameter	Symbol	Min	Typ	Max	Unit
Rise Time (10%~90%)	T _{HSR}	500	—	—	ps
Fall Time (10%~90%)	T _{HSF}	500	—	—	ps
Driver Output Resistance	Z _{HSDRV}	40.5	—	49.5	Ω

6. Mechanical Specifications

6.1 Without Housing

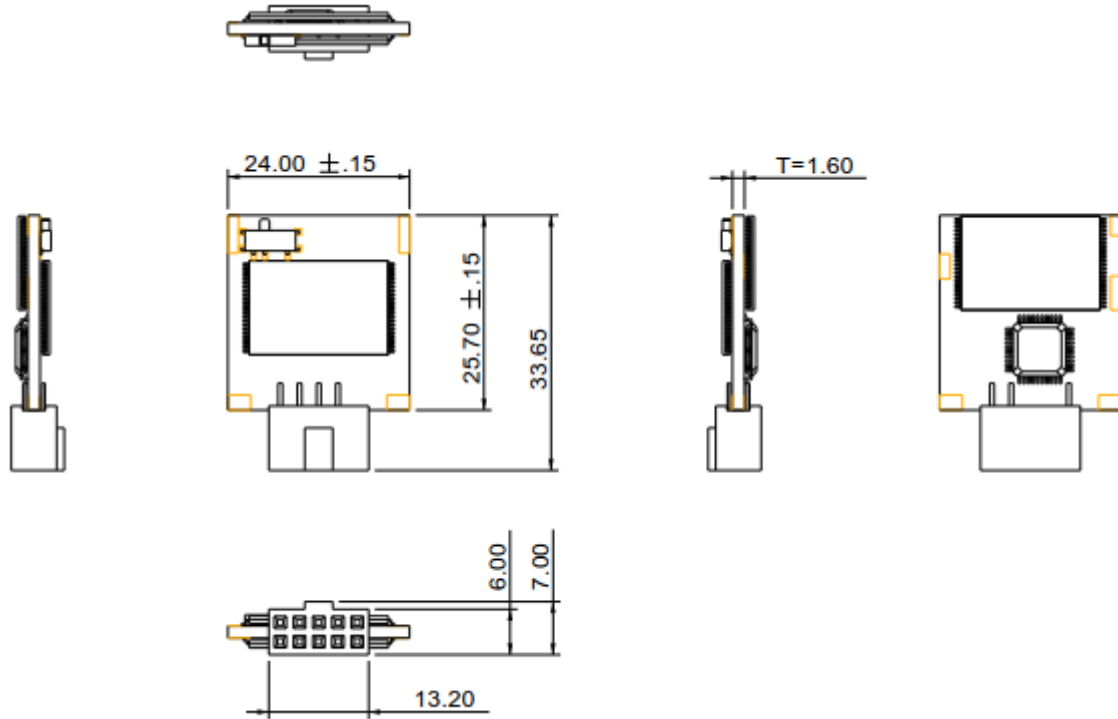

Unit: mm
Tolerance: ± 0.2

Note: Write Protect switch is optional.

USB-Disk Module II Plus AP-UMxxxxXX2XX-2CM



6.2 With Housing

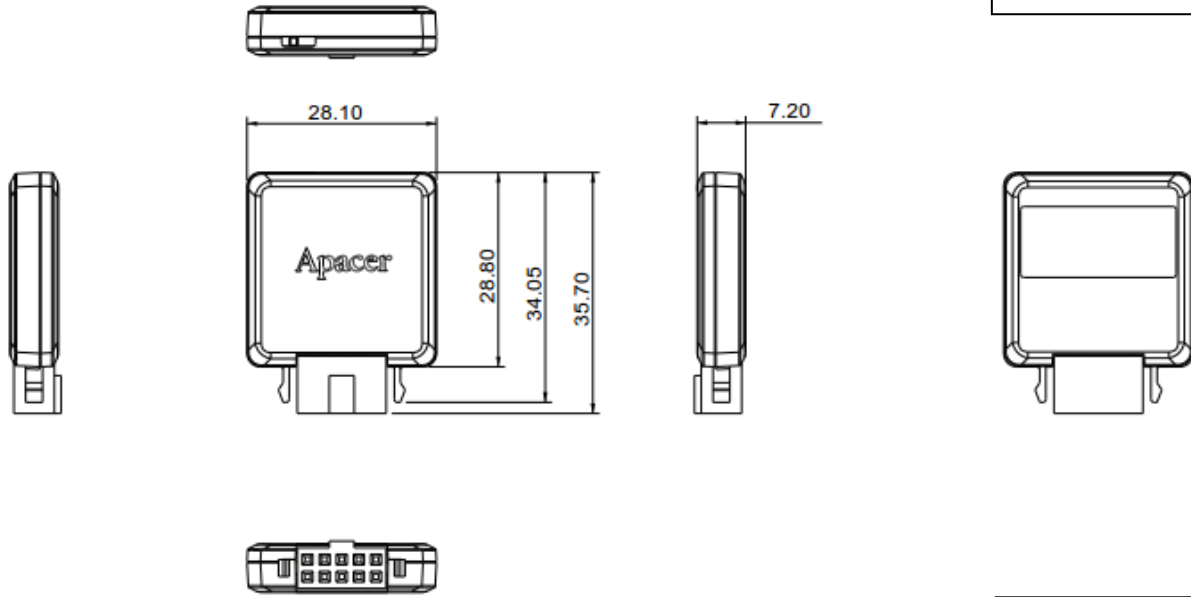

Unit: mm
Tolerance: ± 0.2

Note: Write Protect switch is optional.

Unit: mm
Tolerance: ± 0.2

7. Product Ordering Information

7.1 Product Code Designation

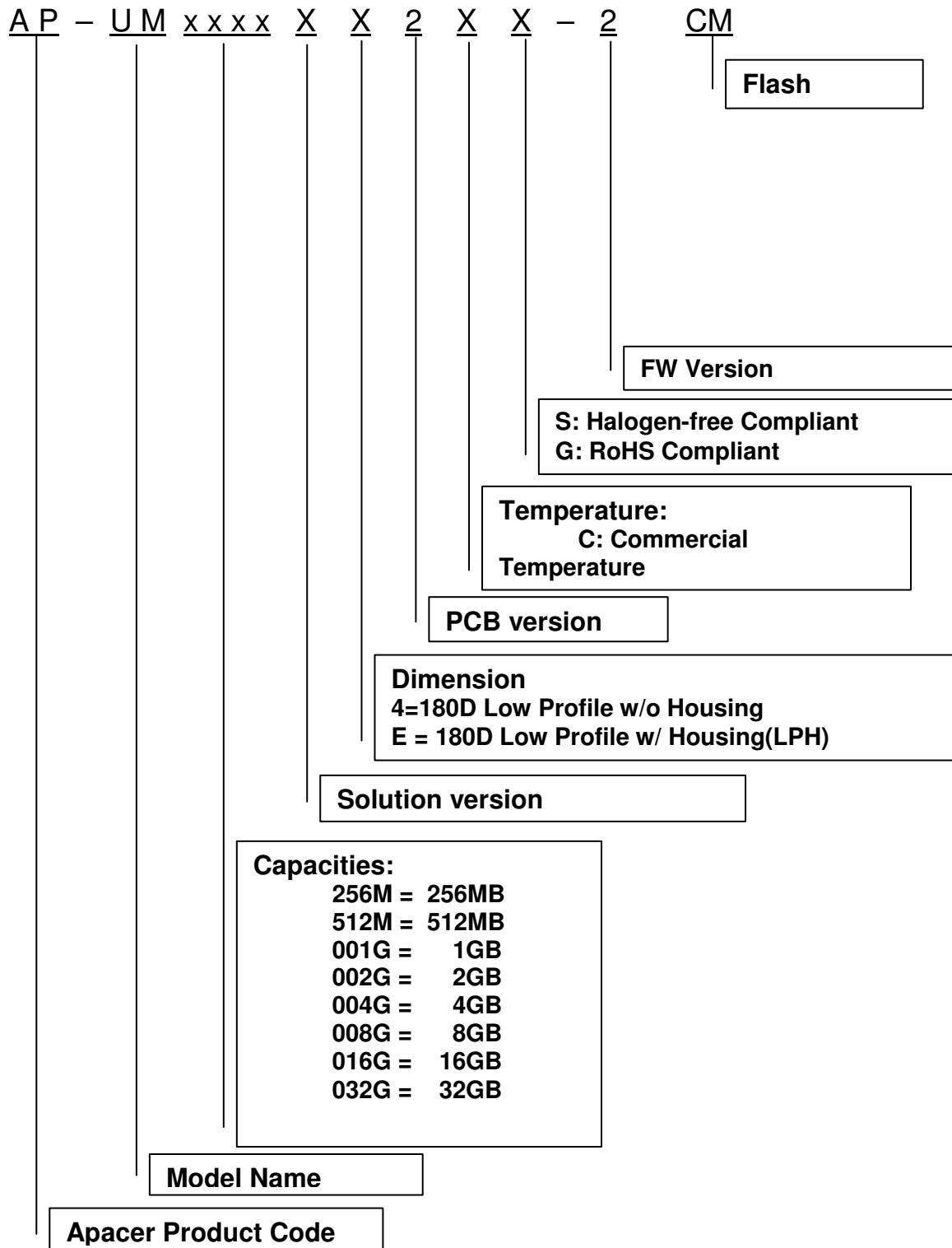

7.2 Valid Combinations

7.2.1 Type D (LP 180D)

Low Profile 180 Degree

Capacity	Standard	Extended Temperature
4GB	AP-UM004GR42CS-2CM	AP-UM004GT42ES-2CM
8GB	AP-UM008GR42CS-2CM	AP-UM008GT42ES-2CM
16GB	AP-UM016GR42CS-2CM	AP-UM016GT42ES-2CM
32GB	AP-UM032GR42CS-2CM	AP-UM032GT42ES-2CM
64GB	AP-UM064GR42CS-2CM	AP-UM064GT42ES-2CM

7.2.11 Type D (LP 180D) - LPH

Low Profile 180 Degree

MLC

Capacity	Standard	Extended Temperature
4GB	AP-UM004GRE2CS-2CM	AP-UM004GTE2ES-2CM
8GB	AP-UM008GRE2CS-2CM	AP-UM008GTE2ES-2CM
16GB	AP-UM001GRE2CS-2CM	AP-UM001GTE2ES-2CM
32GB	AP-UM002GRE2CS-2CM	AP-UM002GTE2ES-2CM
64GB	AP-UM004GRE2CS-2CM	AP-UM004GTE2ES-2CM

Revision History

Revision	Description	Date
1.0	Official Release	09/03/2014

Global Presence

Taiwan (Headquarters)	Apacer Technology Inc. 4 th Fl., 75 Hsin Tai Wu., Sec.1 Hsichih, New Taipei City Taiwan 221 R.O.C. Tel: +886-2-2698-2888 Fax: +886-2-2698-2889 amtsales@apacer.com
U.S.A.	Apacer Memory America, Inc. 386 Fairview Way, Suite102, Milpitas, CA 95035 Tel: 1-408-518-8699 Fax: 1-408-935-9611 sa@apacerus.com
Japan	Apacer Technology Corp. 5F, Matsura Bldg., Shiba, Minato-Ku Tokyo, 105-0014, Japan Tel: 81-3-5419-2668 Fax: 81-3-5419-0018 jpservices@apacer.com
Europe	Apacer Technology B.V. Science Park Eindhoven 5051 5692 EB Son, The Netherlands Tel: 31-40-267-0000 Fax: 31-40-267-0000#6199 sales@apacer.nl
China	Apacer Electronic (Shanghai) Co., Ltd 1301, No.251,Xiaomujiao Road, Shanghai, 200032, China Tel: 86-21-5529-0222 Fax: 86-21-5206-6939 sales@apacer.com.cn
India	Apacer Technologies Pvt. Ltd. # 535, 1st Floor, 8th cross, JP Nagar 3rd Phase, Bangalore – 560078, India Tel: 91-80-4152-9061 sales_india@apacer.com