

RoHS Compliant

USB-Disk Module II Plus

Product Specifications

September 2, 2016

Version 1.8



Apacer Technology Inc.

1F, No.32, Zhongcheng Rd., Tucheng Dist., New Taipei City, Taiwan

Tel: +886-2-2267-8000 Fax: +886-2-2267-2261

www.apacer.com

FEATURES:

- **USB2.0 High-Speed and USB1.1 Full-Speed compatible interface**
- **Capacity**
 - 4, 8, 16, 32, 64 GB
- **Performance***
 - Sustained read: 33 MB/s
 - Sustained write: 16 MB/s
- **Intelligent USB Module**
 - Implements dynamic wear-leveling algorithms to substantially increase longevity of flash media
 - BCH (24 bit) Error Detection Code/Error Correction Code (EDC/ECC)
 - Intrinsic data integrity after power loss
 - Wear leveling algorithm that provides more reliable data storage over an extended period
- **Extended Data Protection (Optional)**
 - Write protection setting by jumper for prevention of data overwrites.
- **NAND Flash Type: MLC**
- **MTBF**
 - Approximately greater than 3.29×10^6 hours
- **Support Ready Boost for Windows Vista**
- **Support boot-up function for OS**
 - Windows XP Embedded
 - Windows CE
 - Linux
- **Temperature Range**
 - Operation:
 - Standard: 0°C to 70°C
 - Extended: -40°C to 85°C
 - Storage: -40°C to 100°C
- **Power Consumption***
 - Active: 175 mA
 - Idle: 80 mA
 - Operating voltage: 5V (with a certain percentage of tolerance)
- **Connector**
 - 10-pin (2x5) female header
- **RoHS Compliant**
- **Support Non-Removable Setting**

*Varies from capacities. The values addressed in Performance and Power consumption are typical and may vary from settings and platforms.

Table of Contents

1. General Description	3
1.1 Performance-optimized Controller.....	3
1.1.1 Power Management Unit (PMU).....	3
1.1.2 SRAM Buffer.....	3
1.1.3 Error Correction Code (ECC).....	3
1.1.4 Wear-Leveling.....	3
1.1.5 Write Protection Mode (Optional)	3
2. Functional Block Diagram	4
3. Pin Assignment	5
3.1 Type A, Type B, and Type C	5
3.2 Type D (STD)	6
4. Performance & Reliability Specifications	7
4.1 Capacity Specifications	7
4.2 Performance Specifications.....	7
4.3 Environmental Specifications	7
4.4 MTBF	8
5. Electrical Specifications	9
5.1 AC Characteristics.....	9
6. Physical Dimensions	11
6.1 Horizontal Design	11
6.1.1 Type A (STD 90D)	11
6.1.2 Type B (STD 90D-MH)	12
6.1.3 Type C (STD 90D-MS)	13
6.2 Vertical Design	14
6.2.1 Type D (STD 180D).....	14
7. Product Ordering Information.....	15
7.1 Product Code Designations.....	15
7.2 Valid Combinations.....	16

1. General Description

Apacer's USB-Disk Module (UDM) is a high performance, embedded solid state drive (SSD) designed to replace a conventional IDE hard disk drive. UDM SSD can be plugged into a standard Embedded USB connector commonly found in desktops, portable PC systems and industrial PC systems. This product is well suited for embedded flash storage applications offering new and expanded functionality as well as more cost-effective designs, better performance and increased reliability.

This UDM solid state drive is resistant to shock and vibration and compatible with widely used operating systems such as Windows CE, Windows XP Embedded, and Linux. In terms of suitability, it comes in various dimensions to multiple embedded usages.

1.1 Performance-optimized Controller

The heart of an UDM is the USB controller, which translates standard USB signals into the data and controls of the flash media. This proprietary USB controller is specifically designed to attain high data throughput from host to flash.

1.1.1 Power Management Unit (PMU)

The power management unit (PMU) controls the power consumption of the UDM. It can dramatically extend product battery life by leaving the idle part of the circuitry into sleep mode. The PMU has zero wake-up latency.

1.1.2 SRAM Buffer

The SRAM buffer is a key contributor to the USB controller performance. It optimizes data writes to the flash.

1.1.3 Error Correction Code (ECC)

The UDM uses BCH Error Detection Code (EDC) and Error Correction Code (ECC) algorithms which correct up to 24 random single-bit errors for each 1024-byte block of data depending on spare area of flash memory. High performance is achieved through hardware-based error detection and correction.

1.1.4 Wear-Leveling

Flash memory can be erased a limited number of times, This number is called the erase cycle limit, or write endurance limit, The erase cycle limit applies to each individual erase block in the flash device.

In a typical application, and especially if a file system is used, specific pages are constantly updated (e.g., the page that contains the FAT, registry, etc.). Without any special handling, these pages would wear out more rapidly than other pages, reducing the lifetime of the entire flash.

To overcome this inherent deficiency, Apacer's USB-Disk Module (UDM) uses wear-leveling algorithm. This wear-leveling algorithm ensures that consecutive writes of a specific sector are not written physically to the same page in the flash. This spreads flash media usage evenly across all pages, thereby maximizing flash lifetime.

The wear-leveling mechanism provides write/erase cycles for reliable data storage over an extended period.

1.1.5 Write Protection Mode (Optional)

When the device is configured to the Write-Protection mode, it enhances the data security and protection. This feature prevents the stored data from inadvertent system writes or erases, and viruses.

2. Functional Block Diagram

The USB-Disk Module (UDM) contains a controller, embedded firmware, and Flash Media with a female connector. The UDM interfaces with the host system allowing data to be written to and read from the Flash Media.

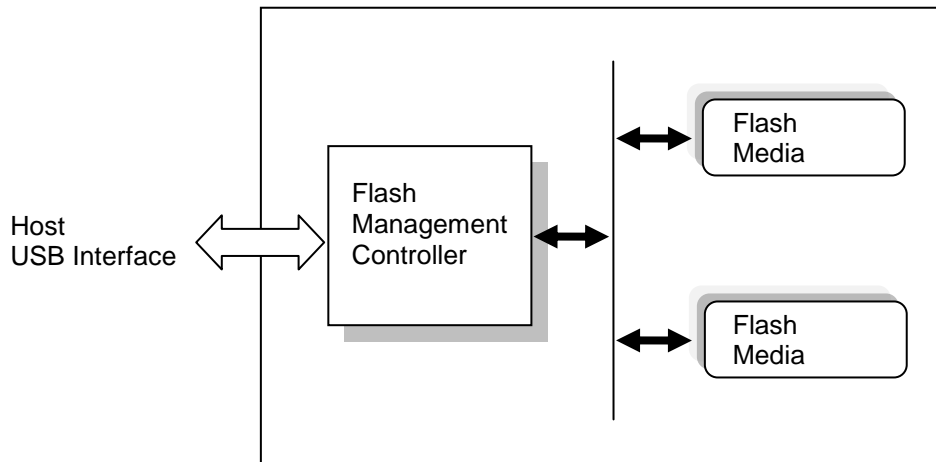

Figure 2-1 Functional Block Diagram

3. Pin Assignment

This chapter provides the information on the pin assignments and signal descriptions.

3.1 Type A, Type B, and Type C

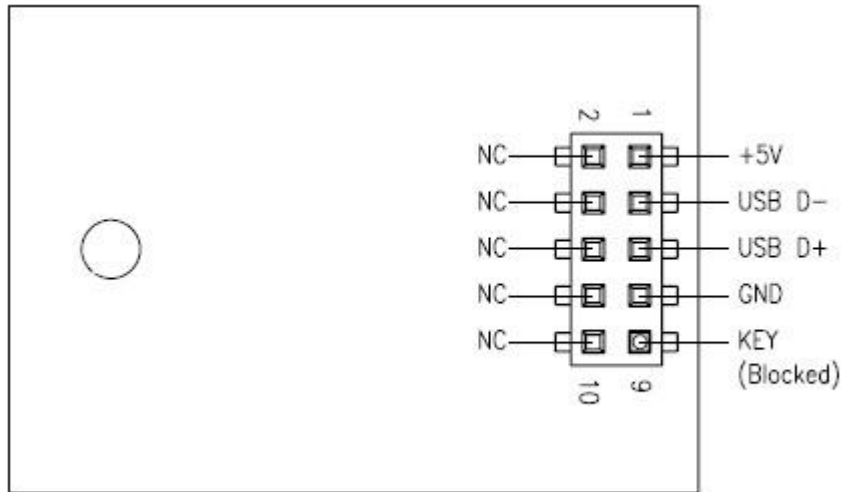

Table 3-1 Pin Assignment of the 10-Pin Configuration in Type A, Type B, and Type C.

Pin	Signal	Pin	Signal
1	+5V	2	N.C
3	USB D-	4	N.C
5	USB D+	6	N.C
7	GND	8	N.C
9	Key (Blocked)	10	N.C

3.2 Type D (STD)

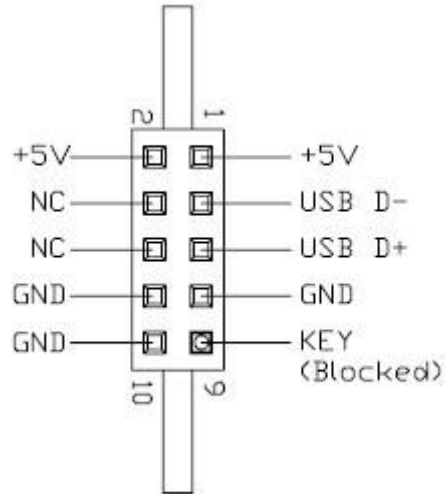

Table 3-2 Pin Assignment of the 10-Pin Configuration in Type D (STD)

Pin	Signal	Pin	Signal
1	+5V	2	+5V
3	USB D-	4	N.C
5	USB D+	6	N.C
7	GND	8	GND
9	Key (Blocked)	10	GND

4. Performance & Reliability Specifications

4.1 Capacity Specifications

The USB-Disk Module product family is available as below table matrix.

Table 4-1 Capacity Specifications

Capacity	Total Bytes
4GB	4,001,382,400
8GB	8,011,153,408
16GB	16,030,662,656
32GB	32,061,325,312
64GB	64,139,362,304

Note: Total user bytes may vary depending on file system in use.

4.2 Performance Specifications

Table 4-2 Performance Specifications

Capacity \ Performance	4 GB	8 GB	16 GB	32 GB	64 GB
	Sustained read (MB/s)	30	34	39	30
Sustained write (MB/s)	10	8	17	19	18

Note: Results may vary depending on flash configurations.

4.3 Environmental Specifications

Environmental specification of the USB-Disk Module (UDM) product family which follows the MIL-STD-810F standards is available as shown in Table 4-3.

Table 4-3 Environmental Specifications

Temperature	Operation	0°C ~70°C (Standard) ; -40°C ~85°C (Extended) ;
	Storage	-40°C to 100°C
Vibration	Sine wave 10 Hz to 500 Hz, 50 m/s ² , 3 axes (IEC 68-2-6, non-operating)	
Shock	Half sine wave 50G, 6 axes, 18 times (IEC 68-2-27, non-operating)	
EMC	FCC, CE	

4.4 MTBF

Mean Time Between Failures (MTBF) is predicted based on reliability data for the individual components in this device. The measurement assumes that device failure rate can be generated by the sum of failure rates in each component and a steady state failure rate can be predicated as equal to or greater than 4.20×10^6 hours.

Note: The MTBF is predicated and calculated based on “Bellcore Analysis Method 1”.

$$\lambda_{SS} = \pi_E \sum_{i=1}^m (N_i \lambda_{SSi})$$

m: number of component types

N_i: quantity of I type component
λ_{SSi}: failure rate for I type component at steady state

π_E: device environment factor

λ_{SS}: device failure rate at steady state

5. Electrical Specifications

Caution: Absolute Maximum Stress Ratings – Applied conditions greater than those listed under “Absolute Maximum Stress Ratings” may cause permanent damage to the device. This is a stress rating only and functional operation of the device at these conditions or conditions greater than those defined in the operational sections of this data sheet is not implied. Exposure to absolute maximum stress rating conditions may affect device reliability.

Table 5-1 Operating Range

Range	Ambient Temperature	Voltage
Standard	0°C to 70°C	4.5-5.5V
Extended	-40°C ~85°C	

Table 5-2 Absolute Maximum Power Pin Stress Ratings

Parameter	Symbol	Min	Max	Unit
Power Supply Input	VDD- VSS	-0.3	5.5	V
Voltage on any pin except VDD with respect to GND	VIN	-ss - 0.3	VDD +0.3	V

Table 5-3 Typical Power Consumption

Modes \ Capacity	Capacity				
	4 GB	8 GB	16 GB	32 GB	64 GB
Active (mA)	120	120	135	175	175
Idle (mA)	75	75	80	80	80

Note: Results may differ from various flash configurations or host system setting.

5.1 AC Characteristics

Table 5-4 AC Characteristics Full Speed

Parameter	Symbol	Min	Typ	Max	Unit
Rise Time	T _{FR}	4	—	20	ns
Fall Time	T _{FF}	4	—	20	ns
Differential Rise and Fall Time Matching	T _{FRFM}	90		111.11	%
Driver Output Resistance	Z _{DRV}	28	—	44	Ω

Table 5-5 AC Characteristics High Speed

Parameter	Symbol	Min	Typ	Max	Unit
Rise Time (10%~90%)	T_{HSR}	500	—	—	ps
Fall Time (10%~90%)	T_{HSF}	500	—	—	ps
Driver Output Resistance	Z_{HSDRV}	40.5	—	49.5	Ω

6. Physical Dimensions

6.1 Horizontal Design

6.1.1 Type A (STD 90D)

Standard 90 degree

Length	28.8mm	Width	26.65mm	Height (Max)	10.5 mm
---------------	--------	--------------	---------	---------------------	---------

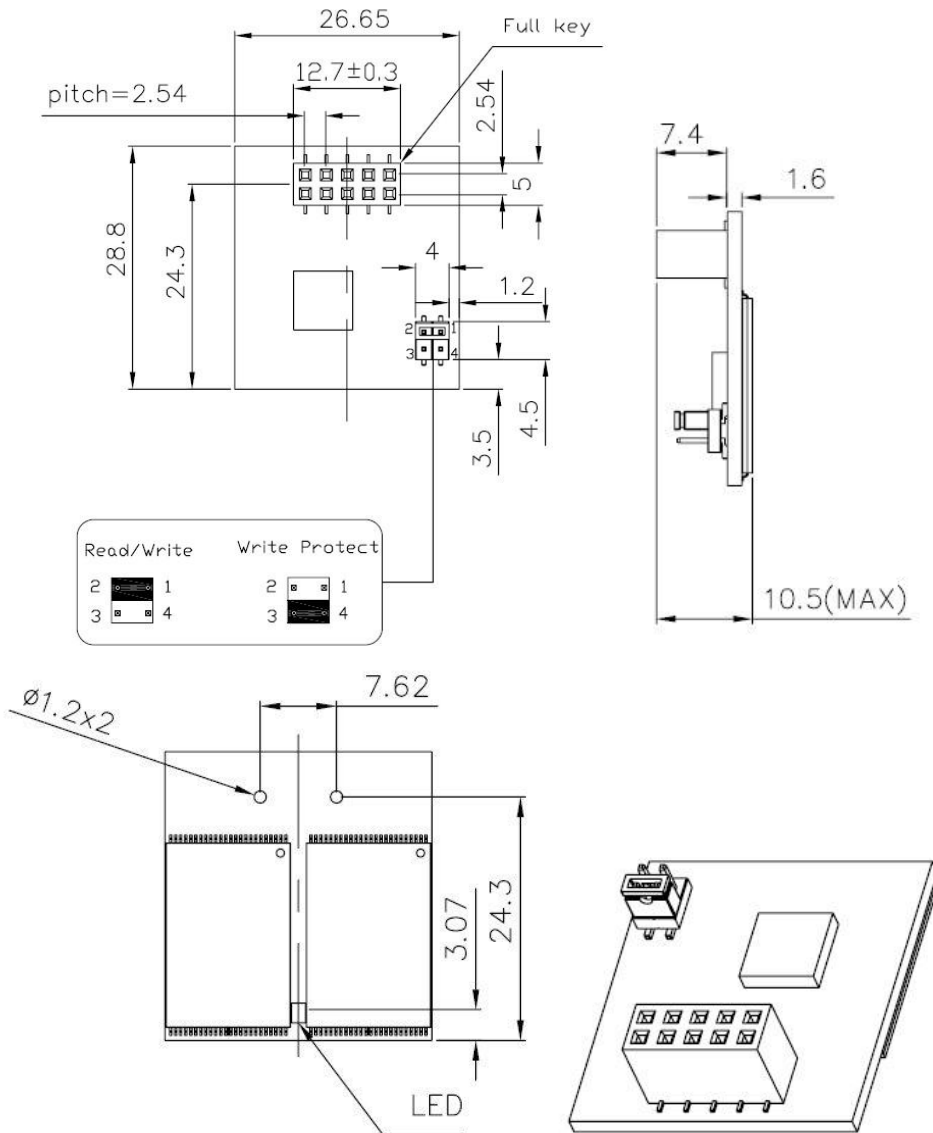

Unit: mm
 Tolerance: ±0.2

USB-Disk Module II Plus AP-UMxxxGXXXXX-2XXXXCM



6.1.2 Type B (STD 90D-MH)

Standard 90 Degree Mounting Header

Length	37.8mm	Width	26.65mm	Height (Max)	10.5 mm
---------------	--------	--------------	---------	---------------------	---------

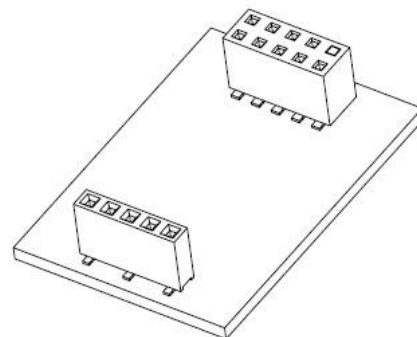
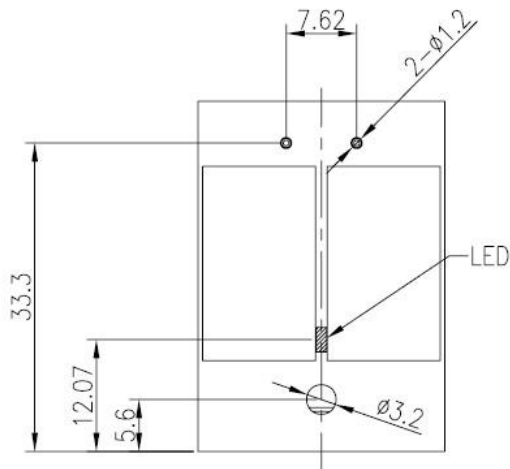
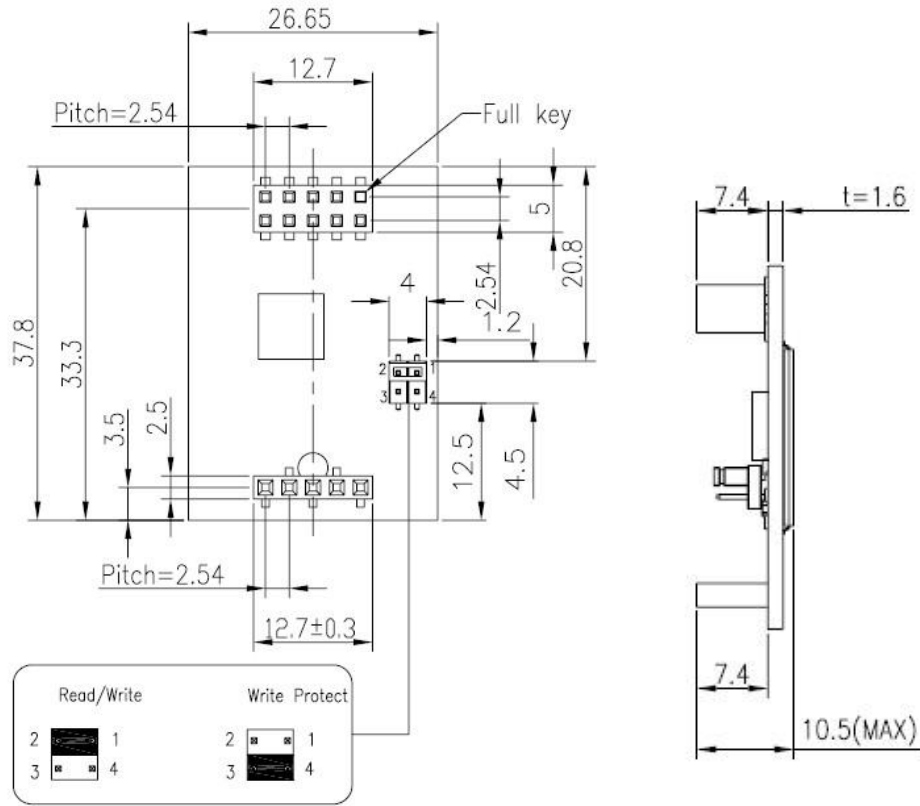

Unit: mm
Tolerance: ± 0.2

USB-Disk Module II Plus AP-UMxxxGXXXXX-2XXXXCM



6.1.3 Type C (STD 90D-MS)

Standard 90 Degree Mounting Screw

Length	37.8mm	Width	26.65mm	Height (Max)	10.5 mm
---------------	--------	--------------	---------	---------------------	---------

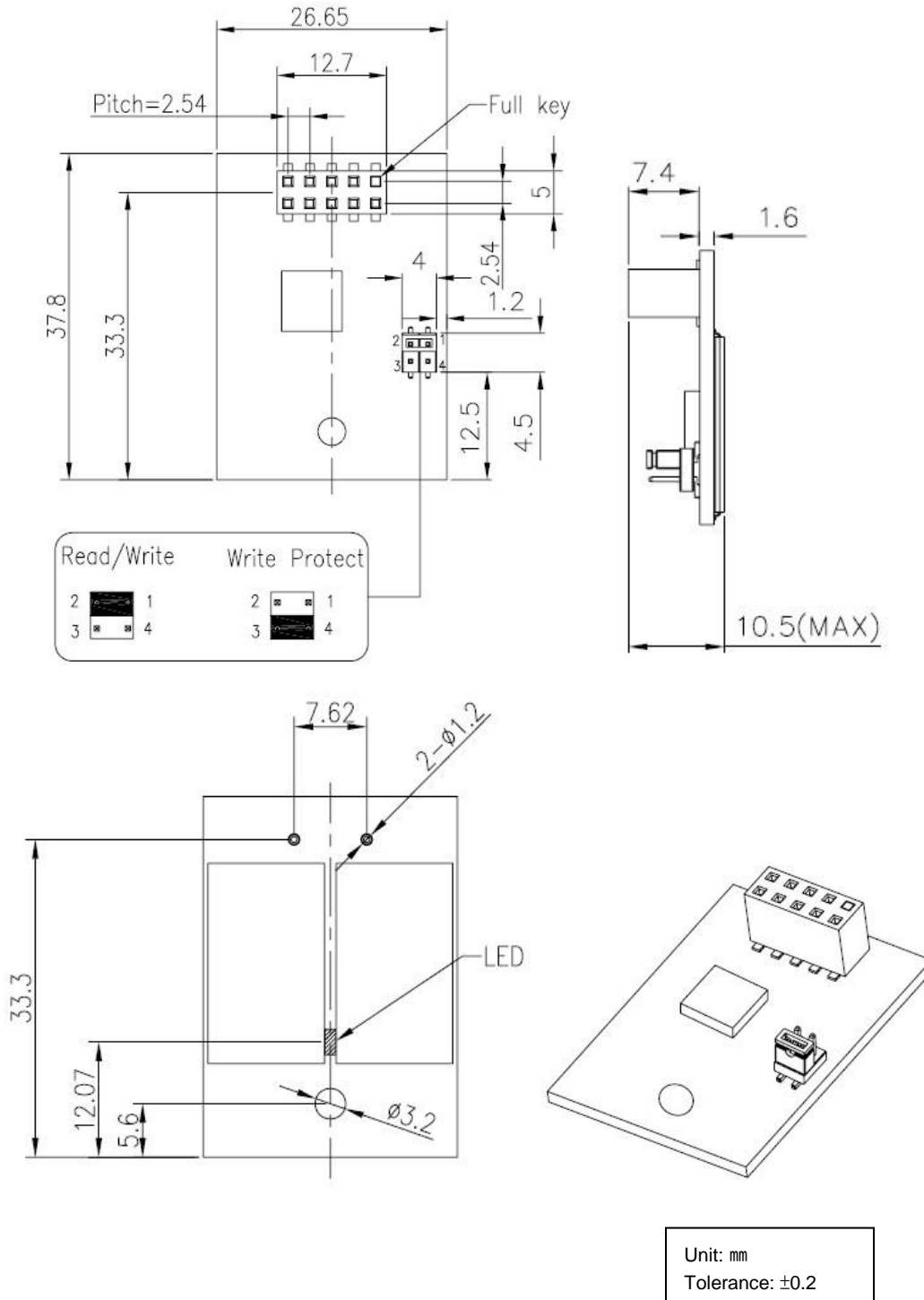

6.2 Vertical Design

6.2.1 Type D (STD 180D)

Standard 180 Degree

Length	37.3mm	Width	26.65mm	Height (Max)	8.5 mm
---------------	--------	--------------	---------	---------------------	--------

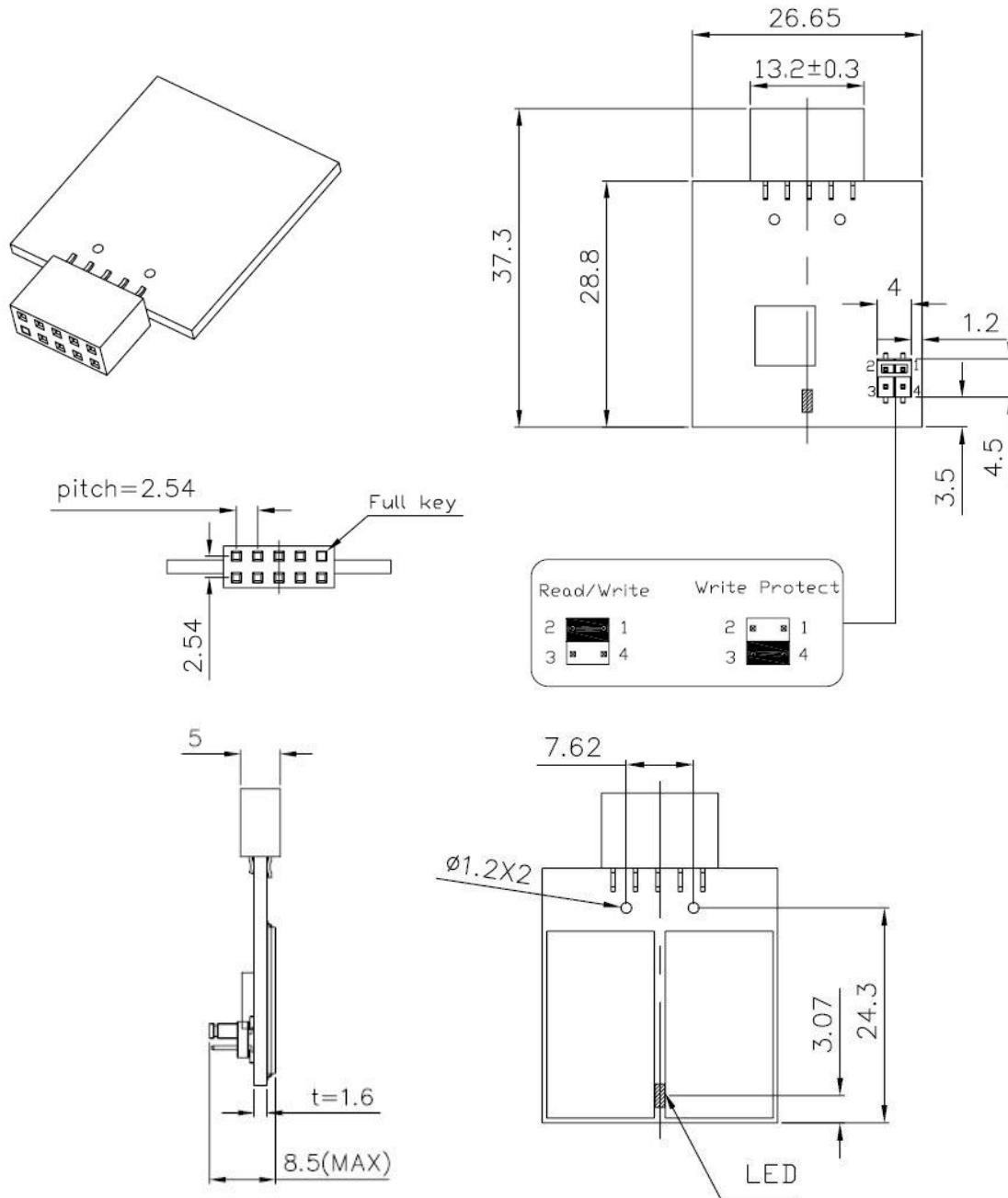

Unit: mm
Tolerance: ±0.2

7. Product Ordering Information

7.1 Product Code Designations

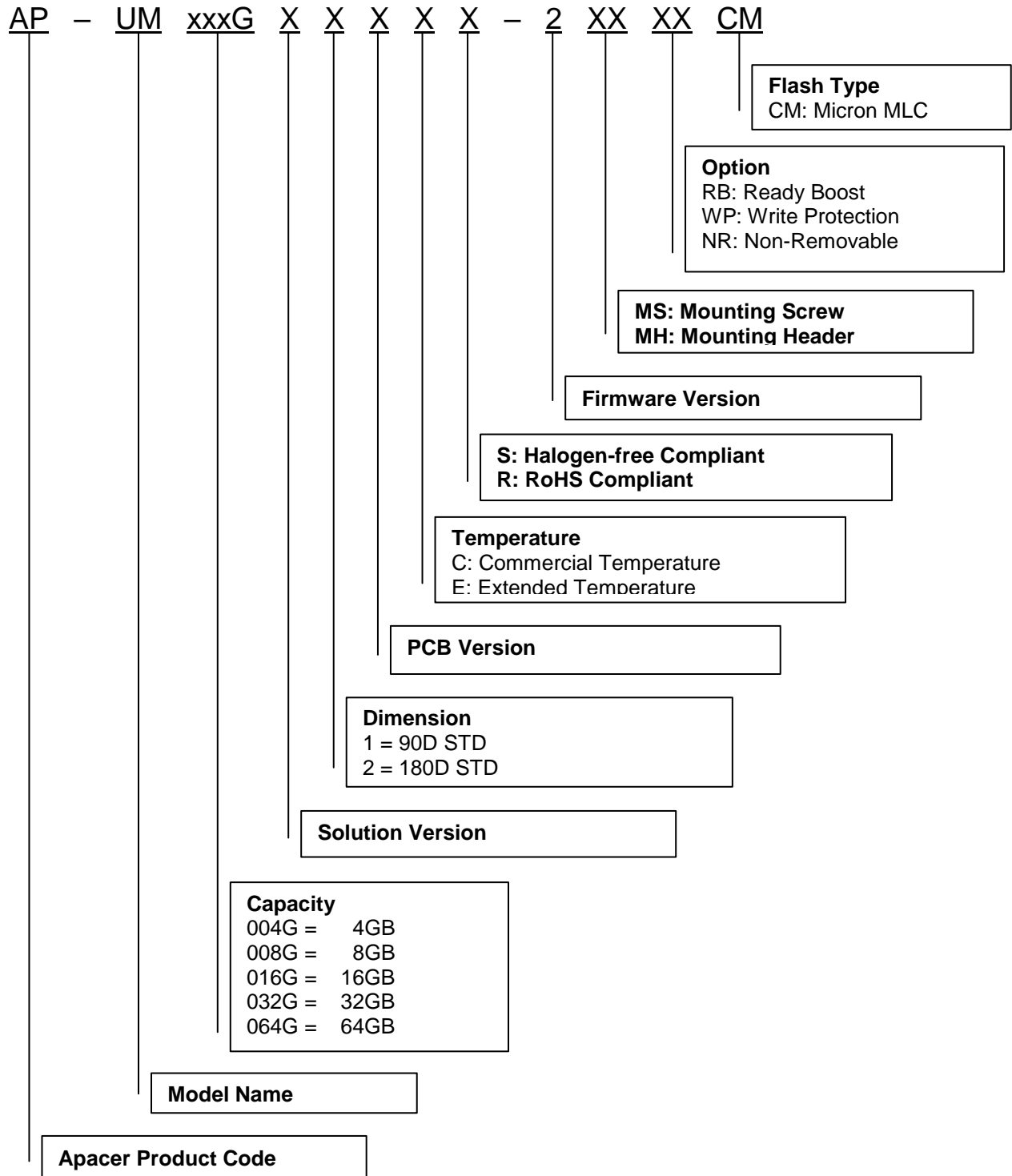

7.2 Valid Combinations

7.2.1 Type A (STD 90D)

Standard 90 degree

Capacity	Standard Temperature	Extended Temperature
4GB	AP-UM004GR13CS-2CM	AP-UM004GT13ES-2CM
8GB	AP-UM008GR13CS-2CM	AP-UM008GT13ES-2CM
16GB	AP-UM016GR13CS-2CM	AP-UM016GT13ES-2CM
32GB	AP-UM032GR13CS-2CM	AP-UM032GT13ES-2CM
64GB	AP-UM064GR13CS-2CM	AP-UM064GT13ES-2CM

7.2.2 Type B (STD 90D-MH)

Standard 90 degree Mounting Header

Capacity	Standard Temperature	Extended Temperature
4GB	AP-UM004GR13CS-2MHCM	AP-UM004GT13ES-2MHCM
8GB	AP-UM008GR13CS-2MHCM	AP-UM008GT13ES-2MHCM
16GB	AP-UM016GR13CS-2MHCM	AP-UM016GT13ES-2MHCM
32GB	AP-UM032GR13CS-2MHCM	AP-UM032GT13ES-2MHCM
64GB	AP-UM064GR13CS-2MHCM	AP-UM064GT13ES-2MHCM

7.2.3 Type C (STD 90D-MS)

Standard 90 degree Mounting Screw

Capacity	Standard Temperature	Extended Temperature
4GB	AP-UM004GR13CS-2MSCM	AP-UM004GT13ES-2MSCM
8GB	AP-UM008GR13CS-2MSCM	AP-UM008GT13ES-2MSCM
16GB	AP-UM016GR13CS-2MSCM	AP-UM016GT13ES-2MSCM
32GB	AP-UM032GR13CS-2MSCM	AP-UM032GT13ES-2MSCM
64GB	AP-UM064GR13CS-2MSCM	AP-UM064GT13ES-2MSCM

7.2.4 Type D (STD 180D)

Standard 180 degree

Capacity	Standard Temperature	Extended Temperature
4GB	AP-UM004GR23CS-2CM	AP-UM004GT23ES-2CM
8GB	AP-UM008GR23CS-2CM	AP-UM008GT23ES-2CM
16GB	AP-UM016GR23CS-2CM	AP-UM016GT23ES-2CM
32GB	AP-UM032GR23CS-2CM	AP-UM032GT23ES-2CM
64GB	AP-UM064GR23CS-2CM	AP-UM064GT23ES-2CM

7.2.5 Type A (STD 90D) – NR

Standard 90 degree

Capacity	Standard Temperature	Extended Temperature
4GB	AP-UM004GR13CS-2NRCM	AP-UM004GT13ES-2NRCM
8GB	AP-UM008GR13CS-2NRCM	AP-UM008GT13ES-2NRCM
16GB	AP-UM016GR13CS-2NRCM	AP-UM016GT13ES-2NRCM
32GB	AP-UM032GR13CS-2NRCM	AP-UM032GT13ES-2NRCM
64GB	AP-UM064GR13CS-2NRCM	AP-UM064GT13ES-2NRCM

7.2.6 Type B (STD 90D-MH) – NR

Standard 90 degree Mounting Header

Capacity	Standard Temperature	Extended Temperature
4GB	AP-UM004GR13CS-2MHNRCM	AP-UM004GT13ES-2MHNRCM
8GB	AP-UM008GR13CS-2MHNRCM	AP-UM008GT13ES-2MHNRCM
16GB	AP-UM016GR13CS-2MHNRCM	AP-UM016GT13ES-2MHNRCM
32GB	AP-UM032GR13CS-2MHNRCM	AP-UM032GT13ES-2MHNRCM
64GB	AP-UM064GR13CS-2MHNRCM	AP-UM064GT13ES-2MHNRCM

7.2.7 Type C (STD 90D-MS) – NR

Standard 90 degree Mounting Screw

Capacity	Standard Temperature	Extended Temperature
4GB	AP-UM004GR13CS-2MSNRCM	AP-UM004GT13ES-2MSNRCM
8GB	AP-UM008GR13CS-2MSNRCM	AP-UM008GT13ES-2MSNRCM
16GB	AP-UM016GR13CS-2MSNRCM	AP-UM016GT13ES-2MSNRCM
32GB	AP-UM032GR13CS-2MSNRCM	AP-UM032GT13ES-2MSNRCM
64GB	AP-UM064GR13CS-2MSNRCM	AP-UM064GT13ES-2MSNRCM

7.2.8 Type D (STD 180D) – NR

Standard 180 degree

Capacity	Standard Temperature	Extended Temperature
4GB	AP-UM004GR23CS-2NRCM	AP-UM004GT23ES-2NRCM
8GB	AP-UM008GR23CS-2NRCM	AP-UM008GT23ES-2NRCM
16GB	AP-UM016GR23CS-2NRCM	AP-UM016GT23ES-2NRCM
32GB	AP-UM032GR23CS-2NRCM	AP-UM032GT23ES-2NRCM
64GB	AP-UM064GR23CS-2NRCM	AP-UM064GT23ES-2NRCM

Revision History

Revision	Description	Date
1.0	Official Release	December 13, 2011
1.1	Added MTBF section	May 10, 2012
1.2	Updated power consumption	June 29, 2012
1.3	Updated contact phone number of Apacer office in America	August 30, 2012
1.4	Updated product ordering information	February 3, 2015
1.5	Added extended temperature support	March 10, 2015
1.6	Revised extended P/N : 7.2.2 , 7.2.3, 7.2.4	March 23, 2015
1.7	Added power consumption section	December 1, 2015
1.8	- Revised performance values - Revised product ordering information	September 2, 2016

Global Presence

Taiwan (Headquarters)	Apacer Technology Inc. 1F., No.32, Zhongcheng Rd., Tucheng Dist., New Taipei City 236, Taiwan R.O.C. Tel: 886-2-2267-8000 Fax: 886-2-2267-2261 amtsales@apacer.com
U.S.A.	Apacer Memory America, Inc. 46732 Lakeview Blvd., Fremont, CA 94538 Tel: 1-408-518-8699 Fax: 1-510-249-9551 sa@apacerus.com
Japan	Apacer Technology Corp. 5F, Matsura Bldg., Shiba, Minato-Ku Tokyo, 105-0014, Japan Tel: 81-3-5419-2668 Fax: 81-3-5419-0018 jpservices@apacer.com
Europe	Apacer Technology B.V. Science Park Eindhoven 5051 5692 EB Son, The Netherlands Tel: 31-40-267-0000 Fax: 31-40-267-0000#6199 sales@apacer.nl
China	Apacer Electronic (Shanghai) Co., Ltd Room D, 22/FL, No.2, Lane 600, JieyunPlaza, Tianshan RD, Shanghai, 200051, China Tel: 86-21-6228-9939 Fax: 86-21-6228-9936 sales@apacer.com.cn
India	Apacer Technologies Pvt Ltd, Unit No.201, "Brigade Corner", 7 th Block Jayanagar, Yediyur Circle, Bangalore – 560082, India Tel: 91-80-4152-9061 Fax: 91-80-4170-0215 sales_india@apacer.com