

**RoHS Compliant**

## **USB-Disk Module II *Plus***

Low-Profile 180D Product Specifications

**May 19, 2023**

**Version 1.3**



**Apacer Technology Inc.**

1F, No.32, Zhongcheng Rd., Tucheng Dist., New Taipei City, Taiwan, R.O.C

Tel: +886-2-2267-8000 Fax: +886-2-2267-2261

[www.apacer.com](http://www.apacer.com)

## Specifications Overview:

- **USB2.0 High-Speed and USB1.1 Full-Speed Compatible Interface**
- **Capacity**
  - 4, 8, 16, 32, 64 GB
- **Performance<sup>1</sup>**
  - Sequential read: Up to 33 MB/sec
  - Sequential write: Up to 16 MB/sec
- **Flash Management**
  - Global Wear Leveling
  - BCH (24 bit) Error Detection Code/Error Correction Code (EDC/ECC)
- **NAND Flash Type: MLC**
- **MTBF: >1,000,000 hours**
- **Temperature Range**
  - Operating:
    - Standard: 0°C to 70°C
    - Wide: -40°C to 85°C
  - Storage: -40°C to 100°C
- **Power Consumption<sup>1</sup>**
  - Operating voltage: 5V (with a certain percentage of tolerance)
  - Active mode: 165 mA
  - Idle mode: 450  $\mu$ A
- **Connector**
  - 10-pin (2x5) female header
- **Supports Boot-Up Function for OS**
  - Windows CE/XP/7 Embedded
  - Linux
- **Write Protect Switch (optional)**
- **RoHS Compliant**

Note:

1. Varies from capacities. The values for performances and power consumptions presented are typical and may vary depending on flash configurations or platform settings. The term idle refers to the standby state of the device.

## Table of Contents

<b>1. General Description .....</b>	<b>3</b>
<b>2. Functional Block .....</b>	<b>3</b>
<b>3. Pin Assignments.....</b>	<b>4</b>
3.1 Without Housing.....	4
3.2 With Housing .....	4
<b>4. Performance Specifications .....</b>	<b>5</b>
4.1 Capacity Specifications .....	5
4.2 Performance Specifications .....	5
4.3 Environmental Specifications .....	5
4.4 Mean Time Between Failures (MTBF).....	6
<b>5. Flash Management .....</b>	<b>7</b>
5.1 Performance-optimized Controller .....	7
5.2 Error Correction Code (ECC) .....	7
5.3 Global Wear Leveling .....	7
5.4 Write Protection Mode (optional).....	7
<b>6. Electrical Specifications.....</b>	<b>8</b>
6.1 Operating Conditions .....	8
6.2 AC Characteristics .....	8
<b>7. Mechanical Specifications.....</b>	<b>9</b>
7.1 Without Housing.....	9
7.2 With Housing .....	10
7.3 Write Protect Switch (optional) .....	11
<b>8. Product Ordering Information.....</b>	<b>12</b>
8.1 Product Code Designations .....	12
8.2 Valid Combinations .....	13
8.2.1 Type D (LP 180D) Low Profile 180 Degree .....	13
8.2.2 Type D (LP 180D) – LPH Low Profile 180 Degree .....	13

## 1. General Description

Apacer's USB-Disk Module (UDM) is a high performance, embedded solid state drive (SSD) designed to replace a conventional IDE hard disk drive. UDM SSD can be plugged into a standard Embedded USB connector commonly found in desktops, portable PC systems and industrial PC systems. This product is well suited for embedded flash storage applications offering new and expanded functionality as well as more cost-effective designs, better performance and increased reliability.

This UDM solid state drive is resistant to shock and vibration and compatible with widely used operating systems such as Windows CE, Windows XP Embedded, and Linux. In terms of suitability, it comes in various dimensions to multiple embedded usages.

## 2. Functional Block

The USB-Disk Module (UDM) contains a controller, embedded firmware, and Flash Media with a female connector. The UDM interfaces with the host system allowing data to be written to and read from the Flash Media.

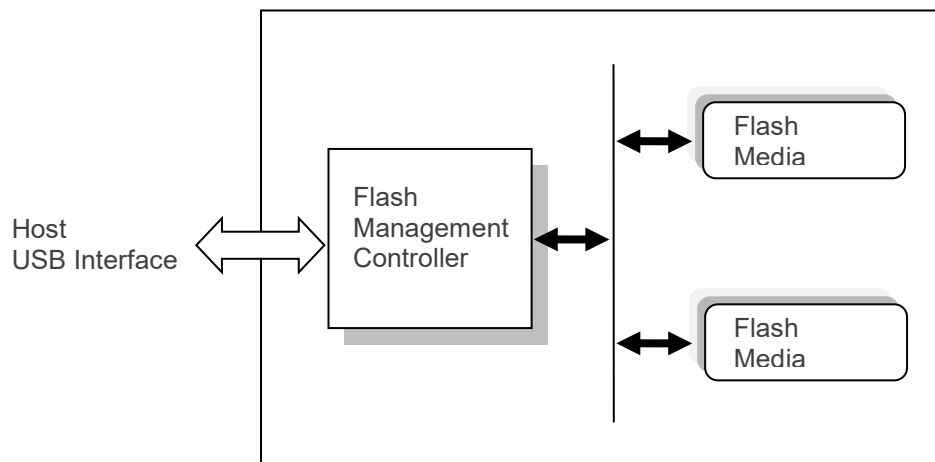

Figure 2-1 Functional Block Diagram

### 3. Pin Assignments

This chapter provides the information on the pin assignments and signal descriptions.

#### 3.1 Without Housing

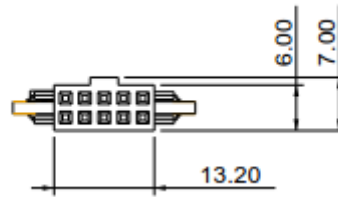

Table 3-1 Pin Assignment of the 10-Pin Configuration

Pin	Signal	Pin	Signal
1	+5V	2	N.C.
3	USB D-	4	N.C.
5	USB D+	6	N.C.
7	GND	8	N.C.
9	N.C.	10	N.C.

#### 3.2 With Housing



Table 3-2 Pin Assignment of the 10-Pin Configuration

Pin	Signal	Pin	Signal
1	+5V	2	N.C.
3	USB D-	4	N.C.
5	USB D+	6	N.C.
7	GND	8	N.C.
9	N.C.	10	N.C.

## 4. Performance Specifications

### 4.1 Capacity Specifications

The USB-Disk Module product family is available as below table matrix.

**Table 4-1 Capacity Specifications**

Capacity	Total bytes
4 GB	4,001,382,400
8 GB	8,011,153,408
16 GB	16,030,662,656
32 GB	32,061,325,312
64 GB	64,139,362,304

Note: The number of total bytes may vary depending on the file system in use.

### 4.2 Performance Specifications

**Table 4-2 Performance Specifications**

Capacity	4 GB	8 GB	16 GB	32 GB	64 GB
<b>Performance</b>					
<b>Sequential Read (MB/s)</b>	32	32	33	33	33
<b>Sequential Write (MB/s)</b>	10	10	14	16	16

Notes:

- Results may differ from various flash configurations or host system setting.
- Sequential read/write is based on CrystalDiskMark 5.2.1 with file size 1,000MB.

### 4.3 Environmental Specifications

Environmental specification of the USB-Disk Module (UDM) product family which follows the MIL-STD-810F standards is available as shown in Table 4-3.

**Table 4-3 Environmental Specifications**

Item	Specifications
Operating temp.	0°C to 70°C (Standard); -40°C to 85°C (Wide)
Non-operating temp.	-40°C to 100°C
Vibration	Sine wave 10 Hz to 500 Hz, 50 m/s <sup>2</sup> , 3 axes (IEC 68-2-6, non-operating)
Shock	Half sine wave 50G, 6 axes, 18 times (IEC 68-2-27, non-operating)
EMC	FCC, CE

Note: This Environmental Specification table indicates the conditions for testing the device. Real world usages may affect the results.

## 4.4 Mean Time Between Failures (MTBF)

Mean Time Between Failures (MTBF) is predicted based on reliability data for the individual components in Apacer's USB flash drive. Serving as statistical reference, the prediction result for Apacer's USB is more than 1,000,000 hours.

Note: The MTBF is predicated and calculated based on "Telcordia Technologies Special Report, SR-332, Issue 3" method.

## 5. Flash Management

### 5.1 Performance-optimized Controller

The heart of an UDM is the USB controller, which translates standard USB signals into the data and controls of the flash media. This proprietary USB controller is specifically designed to attain high data throughput from host to flash.

### 5.2 Error Correction Code (ECC)

The UDM uses BCH Error Detection Code (EDC) and Error Correction Code (ECC) algorithms which correct up to 24 random single-bit errors for each 1024-byte block of data depending on spare area of flash memory. High performance is achieved through hardware-based error detection and correction.

### 5.3 Global Wear Leveling

Flash memory can be erased a limited number of times, This number is called the erase cycle limit, or write endurance limit, The erase cycle limit applies to each individual erase block in the flash device.

In a typical application, and especially if a file system is used, specific pages are constantly updated (e.g., the page that contains the FAT, registry, etc.). Without any special handling, these pages would wear out more rapidly than other pages, reducing the lifetime of the entire flash.

To overcome this inherent deficiency, Apacer's USB-Disk Module (UDM) uses Global Wear Leveling algorithm. This algorithm ensures that consecutive writes of a specific sector are not written physically to the same page in the flash. This spreads flash media usage evenly across all pages, thereby maximizing flash lifetime.

The Global Wear Leveling mechanism provides write/erase cycles for reliable data storage over an extended period.

### 5.4 Write Protection Mode (optional)

When the device is configured to the Write-Protection mode, it enhances the data security and protection. This feature prevents the stored data from inadvertent system writes or erases, and viruses.

## 6. Electrical Specifications

### 6.1 Operating Conditions

**Caution: Absolute Maximum Stress Ratings** – Applied conditions greater than those listed under “Absolute Maximum Stress Ratings” may cause permanent damage to the device. This is a stress rating only and functional operation of the device at these conditions or conditions greater than those defined in the operational sections of this data sheet is not implied. Exposure to absolute maximum stress rating conditions may affect device reliability.

Table 6-1 Operating Range

Item	Range
Supply Voltage	5V $\pm$ 5% (4.5-5.5V)
Standard Temperature	0°C to 70°C
Wide Temperature	-40°C to 85°C

Table 6-2 Absolute Maximum Power Pin Stress Ratings

Parameter	Symbol	Min	Max	Unit
Power Supply Input	VDD- VSS	-0.3	5.5	V
Voltage on any pin except VDD with respect to GND	VIN	-ss - 0.3	VDD +0.3	V

### 6.2 AC Characteristics

Table 6-3 AC Characteristics Full Speed

Parameter	Symbol	Min	Typ	Max	Unit
Rise Time	TFR	4	—	20	ns
Fall Time	TFF	4	—	20	ns
Differential Rise and Fall Time Matching	TFRFM	90		111.11	%
Driver Output Resistance	ZDRV	28	—	44	$\Omega$

Table 6-4 AC Characteristics High Speed

Parameter	Symbol	Min	Typ	Max	Unit
Rise Time (10%~90%)	T <sub>HSR</sub>	500	—	—	ps
Fall Time (10%~90%)	T <sub>HSF</sub>	500	—	—	ps
Driver Output Resistance	Z <sub>HSDRV</sub>	40.5	—	49.5	$\Omega$

## 7. Mechanical Specifications

### 7.1 Without Housing

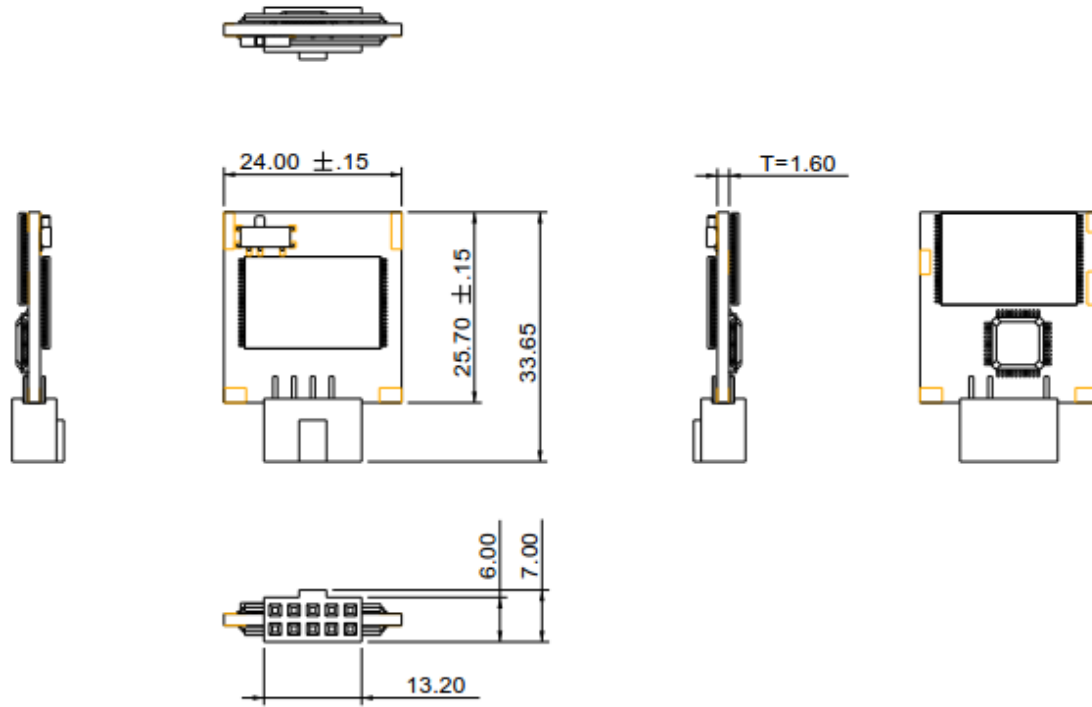

Figure 7-1 Physical Dimensions without Housing

Unit: mm  
Tolerance:  $\pm 0.2$

## 7.2 With Housing

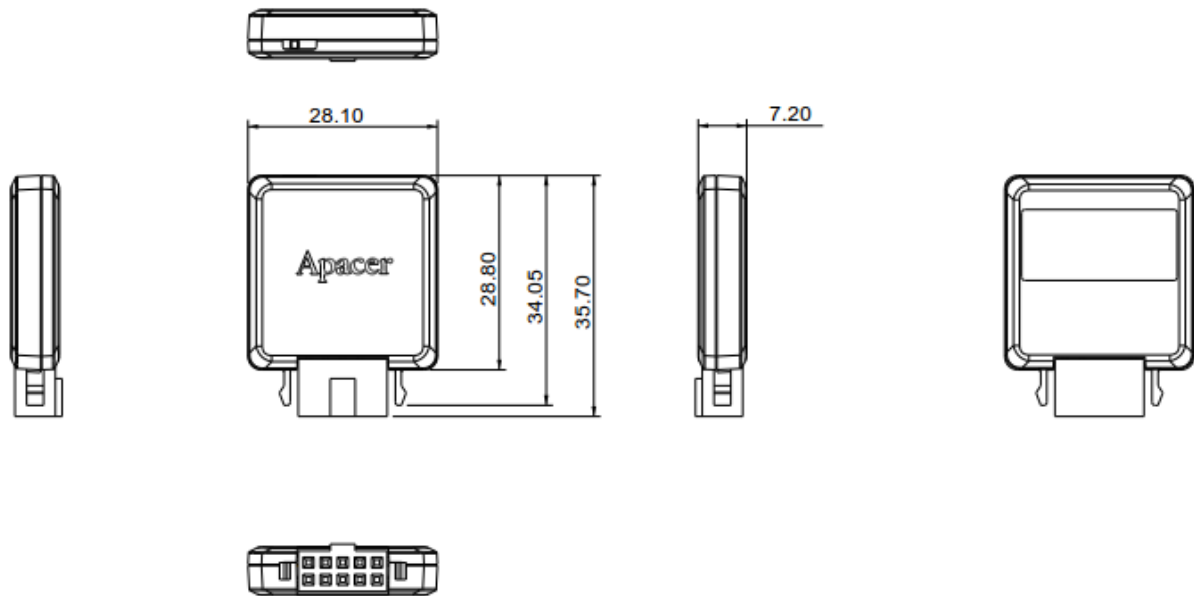

Figure 7-2 Physical Dimensions with Housing

Unit: mm  
Tolerance:  $\pm 0.2$



### 7.3 Write Protect Switch (optional)

Apacer implements the Virtual Write scheme that allows write commands to go through the flash controller and data temporarily stored, but no data has been actually written into the flash. Once the system is reset and rebooted, the temporarily stored data will be lost and nowhere to be found in the system. Since the Virtual Write scheme runs at device level, it requires no software or driver installation and is independent from the host OS.

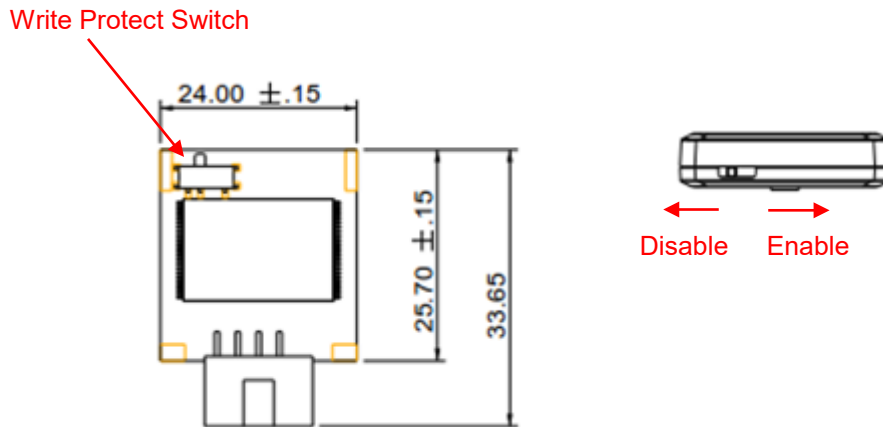
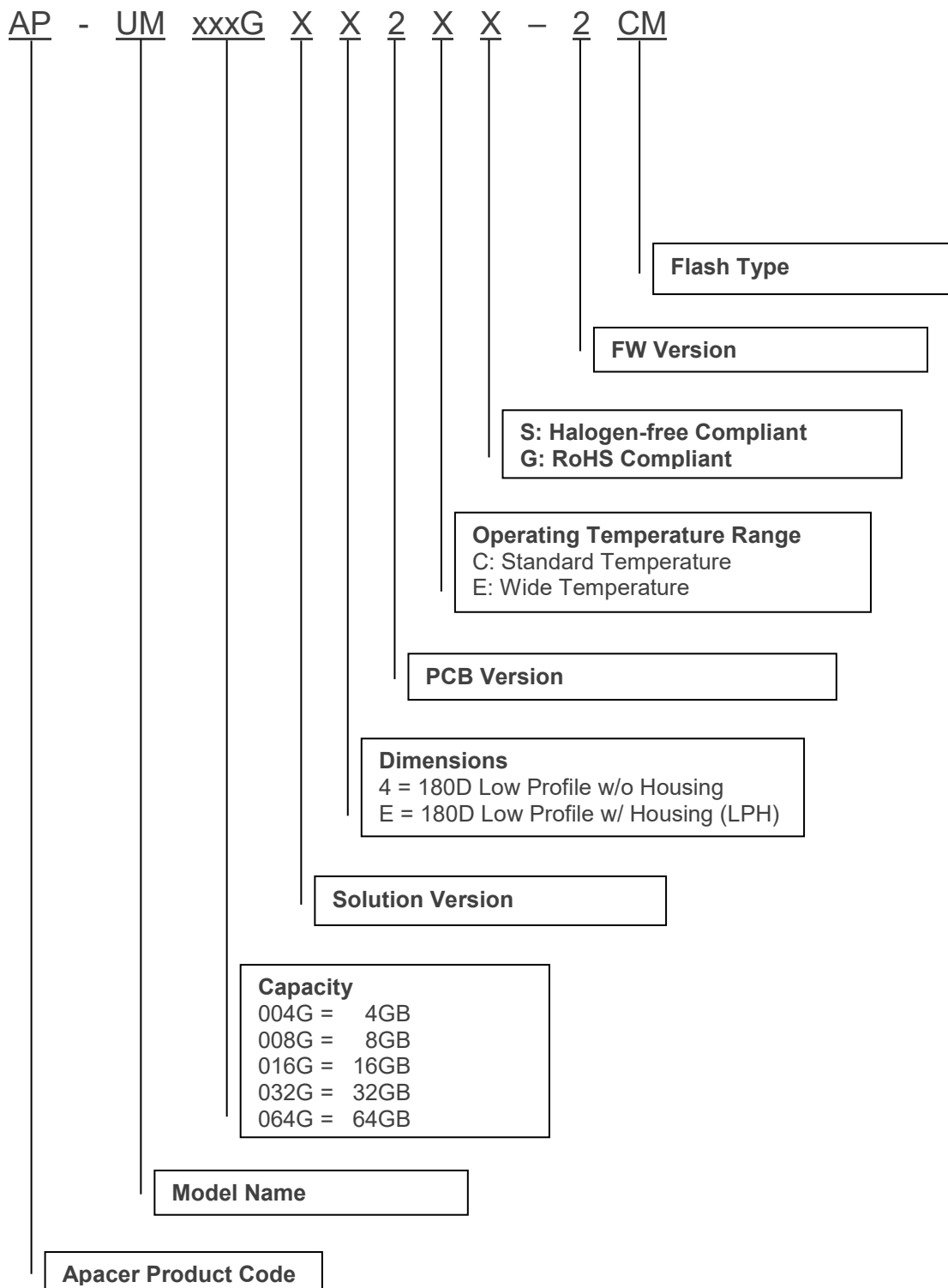

Figure 7-3 Write Protect Switch

## 8. Product Ordering Information

### 8.1 Product Code Designations



## 8.2 Valid Combinations

The following table lists the available models of the USB-Disk Module series which are in mass production or will be in mass production. Consult your Apacer sales representative to confirm availability of valid combinations and to determine availability of new combinations.

### 8.2.1 Type D (LP 180D) Low Profile 180 Degree

Capacity	Standard Temperature	Wide Temperature
4GB	AP-UM004GR42CS-2CM	AP-UM004GT42ES-2CM
8GB	AP-UM008GR42CS-2CM	AP-UM008GT42ES-2CM
16GB	AP-UM016GR42CS-2CM	AP-UM016GT42ES-2CM
32GB	AP-UM032GR42CS-2CM	AP-UM032GT42ES-2CM
64GB	AP-UM064GR42CS-2CM	AP-UM064GT42ES-2CM

### 8.2.2 Type D (LP 180D) – LPH Low Profile 180 Degree

Capacity	Standard Temperature	Wide Temperature
4GB	AP-UM004GRE2CS-2CM	AP-UM004GTE2ES-2CM
8GB	AP-UM008GRE2CS-2CM	AP-UM008GTE2ES-2CM
16GB	AP-UM001GRE2CS-2CM	AP-UM001GTE2ES-2CM
32GB	AP-UM002GRE2CS-2CM	AP-UM002GTE2ES-2CM
64GB	AP-UM004GRE2CS-2CM	AP-UM004GTE2ES-2CM

## Revision History

Revision	Description	Date
1.0	Official Release	9/11/2014
1.1	- Renamed extended temperature to wide temperature - Revised Table 3-2	9/3/2019
1.2	Updated storage temperature from -40°C-85°C to -40°C-100°C	11/23/2021
1.3	Updated the signal of pin 9 to N.C. at Table 3-1 and 3-2	5/19/2023

## Global Presence

### Taiwan (Headquarters)

#### Apacer Technology Inc.

1F., No.32, Zhongcheng Rd., Tucheng Dist.,  
New Taipei City 236, Taiwan R.O.C.  
Tel: 886-2-2267-8000  
Fax: 886-2-2267-2261  
[amtsales@apacer.com](mailto:amtsales@apacer.com)

### U.S.A.

#### Apacer Memory America, Inc.

46732 Lakeview Blvd., Fremont, CA 94538  
Tel: 1-408-518-8699  
Fax: 1-510-249-9551  
[sa@apacerus.com](mailto:sa@apacerus.com)

### Japan

#### Apacer Technology Corp.

6F, Daiyontamachi Bldg., 2-17-12, Shibaura, Minato-Ku,  
Tokyo, 108-0023, Japan  
Tel: 81-3-5419-2668  
Fax: 81-3-5419-0018  
[jpservices@apacer.com](mailto:jpservices@apacer.com)

### Europe

#### Apacer Technology B.V.

Science Park Eindhoven 5051 5692 EB Son,  
The Netherlands  
Tel: 31-40-267-0000  
Fax: 31-40-290-0686  
[sales@apacer.nl](mailto:sales@apacer.nl)

### China

#### Apacer Electronic (Shanghai) Co., Ltd

Room D, 22/FL, No.2, Lane 600, JieyunPlaza,  
Tianshan RD, Shanghai, 200051, China  
Tel: 86-21-6228-9939  
Fax: 86-21-6228-9936  
[sales@apacer.com.cn](mailto:sales@apacer.com.cn)

### India

#### Apacer Technologies Pvt Ltd,

1874, South End C Cross, 9<sup>th</sup> Block Jayanagar,  
Bangalore-560069, India  
Tel: 91-80-4152-9061/62  
Fax: 91-80-4170-0215  
[sales\\_india@apacer.com](mailto:sales_india@apacer.com)