

RoHS Recast Compliant
USB-Disk Module II *Plus*
Product Specifications

October 17, 2017

Version 2.7



Apacer Technology Inc.

1F, No.32, Zhongcheng Rd., Tucheng Dist., New Taipei City, Taiwan, R.O.C

Tel: +886-2-2267-8000 Fax: +886-2-2267-2261

www.apacer.com

Features:

- **USB2.0 High-Speed and USB1.1 Full-Speed Compatible Interface**
- **Capacity**
 - 256, 512 MB
 - 1, 2, 4, 8, 16, 32 GB
- **Performance***
 - Sequential read: Up to 39 MB/sec
 - Sequential write: Up to 29 MB/sec
- **Intelligent USB Module**
 - Advanced wear-leveling algorithms to substantially increase longevity of flash media
 - BCH (24 bit) Error Detection Code/Error Correction Code (EDC/ECC)
 - Intrinsic data integrity after power loss
 - S.M.A.R.T.
- **Extended Data Protection (optional)**
 - Write protection setting by jumper for prevention of data overwrites
- **NAND Flash Type: SLC**
- **MTBF**
 - Approximately greater than 4.20×10^6 hours
- **Temperature Range**
 - Operating:
 - Standard: 0°C to 70°C
 - Extended: -40°C to 85°C
 - Storage: -40°C to 85°C
- **Power Consumption**
 - Active mode: 181 mA
 - Idle mode: 70 mA
 - Operating voltage: 5V (with a certain percentage of tolerance)
- **Connector**
 - 10-pin (2x5) female header
- **Support Boot-Up Function for OS**
 - Windows XP Embedded
 - Windows CE
 - Linux
 - Windows 7
- **Supports Non-Removable Setting**
- **RoHS Recast Compliant (2011/65/EU)**

*Varies from capacities. The values for performances and power consumptions presented are typical and may vary depending on flash configurations or platform settings. The term idle refers to the standby state of the device.

Table of Contents

1. General Descriptions	3
1.1 Performance-Optimized Controller	3
1.1.1 Error Correction Code (ECC).....	3
1.1.2 Wear-Leveling Algorithms.....	3
1.1.3 Write Protection Mode (optional)	3
1.1.4 S.M.A.R.T.	3
2. Functional Block	4
3. Pin Assignments.....	5
3.1 Type A, Type B, and Type C	5
3.2 Type D (STD)	6
4. Performance & Reliability Specifications	7
4.1 Capacity Specifications	7
4.2 Performance Specifications.....	7
4.3 Environmental Specifications	7
4.4 Mean Time Between Failures (MTBF)	8
5. Electrical Specifications	9
5.1 Operating Conditions.....	9
5.2 AC Characteristics.....	9
6. Physical Characteristics.....	10
6.1 Horizontal Design	10
6.1.1 Type A (STD 90D)	10
6.1.2 Type B (STD 90D-MH)	11
6.1.3 Type C (STD 90D-MS)	12
6.2 Vertical Design	13
6.2.1 Type D (STD 180D).....	13
7. Product Ordering Information.....	14
7.1 Product Code Designations.....	14
7.2 Valid Combinations.....	15
7.2.1 Type A (STD 90D) Standard 90 Degree.....	15
7.2.2 Type B (STD 90D-MH) Standard 90 Degree Mounting Header	15
7.2.3 Type C (STD 90D-MS) Standard 90 Degree Mounting Screw.....	15
7.2.4 Type D (STD 180D) Standard 180 Degree	16
7.2.5 Type A (STD 90D) – NR Standard 90 Degree	16
7.2.6 Type B (STD 90D-MH) – NR Standard 90 Degree Mounting Header.....	16
7.2.7 Type C (STD 90D-MS) – NR Standard 90 Degree Mounting Screw.....	17
7.2.8 Type D (STD 180D) – NR Standard 180 Degree	17

1. General Descriptions

Apacer's USB-Disk Module (UDM) is a high performance, embedded solid state drive (SSD) designed to replace a conventional IDE hard disk drive. UDM SSD can be plugged into a standard Embedded USB connector commonly found in desktops, portable PC systems and industrial PC systems. This product is well suited for embedded flash storage applications offering new and expanded functionality as well as more cost-effective designs, better performance and increased reliability.

1.1 Performance-Optimized Controller

The heart of an UDM is the USB controller, which translates standard USB signals into the data and controls of the flash media. This proprietary USB controller is specifically designed to attain high data throughput from host to flash.

1.1.1 Error Correction Code (ECC)

The UDM uses BCH Error Detection Code (EDC) and Error Correction Code (ECC) algorithms which correct up to 24 random single-bit errors for each 1024-byte block of data depending on spare area of flash memory. High performance is achieved through hardware-based error detection and correction.

1.1.2 Wear-Leveling Algorithms

Flash memory can be erased a limited number of times, This number is called the erase cycle limit, or write endurance limit, The erase cycle limit applies to each individual erase block in the flash device.

In a typical application, and especially if a file system is used, specific pages are constantly updated (e.g., the page that contains the FAT, registry, etc.). Without any special handling, these pages would wear out more rapidly than other pages, reducing the lifetime of the entire flash.

To overcome this inherent deficiency, Apacer's USB-Disk Module (UDM) uses wear-leveling algorithm. This wear-leveling algorithm ensures that consecutive writes of a specific sector are not written physically to the same page in the flash. This spreads flash media usage evenly across all pages, thereby maximizing flash lifetime.

The wear-leveling mechanism provides write/erase cycles for reliable data storage over an extended period.

1.1.3 Write Protection Mode (optional)

When the device is configured to the Write-Protection mode, it enhances the data security and protection. This feature prevents the stored data from inadvertent system writes or erases, and viruses.

1.1.4 S.M.A.R.T.

S.M.A.R.T. is an acronym for Self-Monitoring, Analysis and Reporting Technology, an open standard allowing disk drives to automatically monitor their own health and report potential problems. It protects the user from unscheduled downtime by monitoring and storing critical drive performance and calibration parameters. Ideally, this should allow taking proactive actions to prevent impending drive failure. Apacer SMART feature adopts the standard SMART command B0h to read data from the drive. When the Apacer SMART Utility running on the host, it analyzes and reports the disk status to the host before the device is in critical condition.

2. Functional Block

The USB-Disk Module (UDM) contains a controller, embedded firmware, and Flash Media with a female connector. The UDM interfaces with the host system allowing data to be written to and read from the Flash Media.

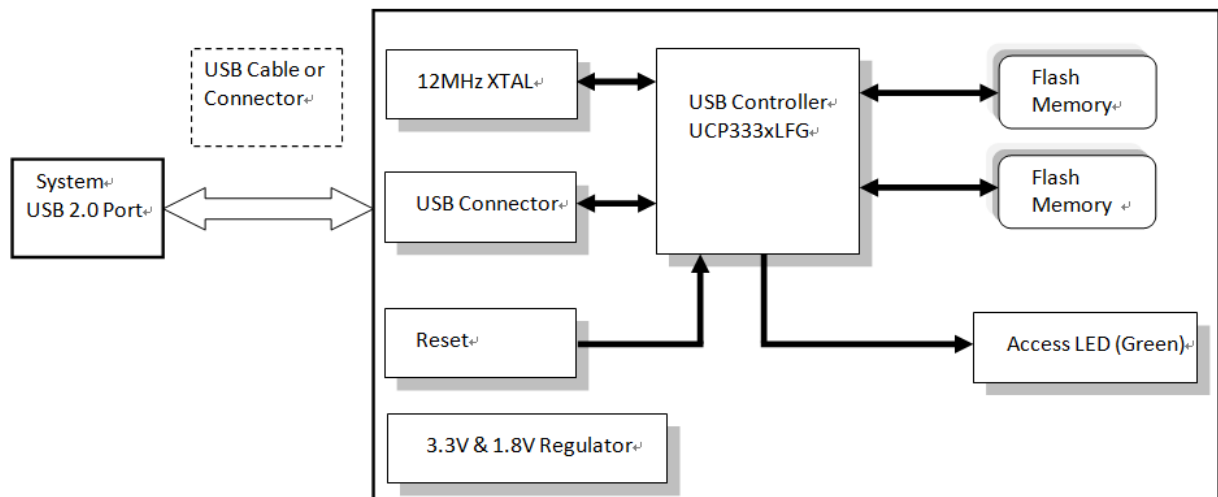

Figure 2-1 Functional Block Diagram

3. Pin Assignments

This chapter provides the information on the pin assignments and signal descriptions.

3.1 Type A, Type B, and Type C

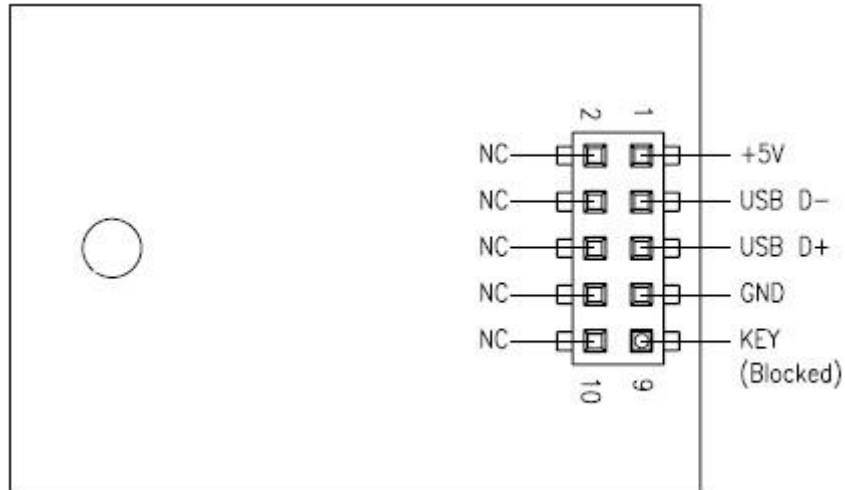

Table 3-1 Pin Assignment of the 10-Pin Configuration in Type A, Type B, and Type C

Pin	Signal	Pin	Signal
1	+5V	2	N.C
3	USB D-	4	N.C
5	USB D+	6	N.C
7	GND	8	N.C
9	Key (Blocked)	10	N.C

3.2 Type D (STD)

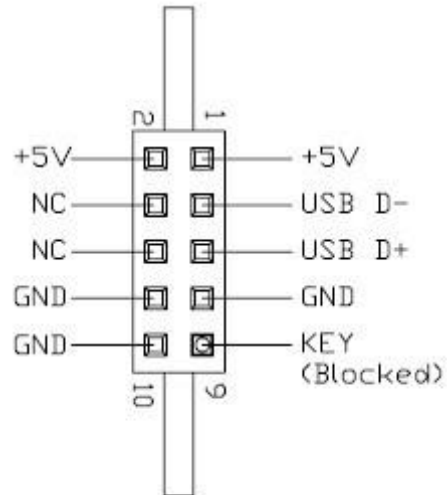

Table 3-2 Pin Assignment of the 10-Pin Configuration in Type D (STD)

Pin	Signal	Pin	Signal
1	+5V	2	+5V
3	USB D-	4	N.C
5	USB D+	6	N.C
7	GND	8	GND
9	Key (Blocked)	10	GND

4. Performance & Reliability Specifications

4.1 Capacity Specifications

The USB-Disk Module product family is available as below table matrix.

Table 4-1 Capacity Specifications

Capacity	Total bytes*
256MB	254,509,056
512 MB	500,924,416
1GB	1,029,406,720
2GB	2,061,205,504
4GB	4,003,479,552
8GB	8,248,131,584
16GB	16,030,662,656
32GB	32,061,292,544

Note: The number of total bytes may vary depending on the file system in use.

4.2 Performance Specifications

Table 4-2 Performance Specifications

Capacity \ Performance	256 MB	512 MB	1 GB	2 GB	4 GB	8 GB	16 GB	32 GB
	Sequential Read* (MB/s)	31	31	32	34	39	32	34
Sequential Write* (MB/s)	10	15	19	19	29	15	22	21

Note:

Results may differ from various flash configurations or host system setting.

*Sequential performance is based on CrystalDiskMark 5.2.1 with file size 1,000MB.

4.3 Environmental Specifications

Environmental specification of the USB-Disk Module (UDM) product family which follows the MIL-STD-810F standards is available as shown in Table 4-3.

Table 4-3 Environmental Specifications

Item	Specifications
Operating temp.	0°C to 70°C (Standard); -40°C to 85°C (Extended)
Non-operating temp.	-40°C to 85°C
Vibration	Sine wave 10 Hz to 500 Hz, 50 m/s ² , 3 axes (IEC 68-2-6, non-operating)
Shock	Half sine wave 50G, 6 axes, 18 times (IEC 68-2-27, non-operating)
EMC	FCC, CE

4.4 Mean Time Between Failures (MTBF)

Mean Time Between Failures (MTBF) is predicted based on reliability data for the individual components in this device. The measurement assumes that device failure rate can be generated by the sum of failure rates in each component and a steady state failure rate can be predicated as equal to or greater than 4.20×10^6 hours.

Note: The MTBF is predicated and calculated based on "Bellcore Analysis Method 1".

$$\lambda_{SS} = \pi_E \sum_{i=1}^m (N_i \lambda_{SSi})$$

m : number of component types

λ_{SS} : device failure rate at steady state

N_i : quantity of i type component

λ_{SSi} : failure rate for i type component at steady state

π_E : device environment factor

5. Electrical Specifications

5.1 Operating Conditions

Caution: Absolute Maximum Stress Ratings – Applied conditions greater than those listed under “Absolute Maximum Stress Ratings” may cause permanent damage to the device. This is a stress rating only and functional operation of the device at these conditions or conditions greater than those defined in the operational sections of this data sheet is not implied. Exposure to absolute maximum stress rating conditions may affect device reliability.

Table 5-1 Operating Range

Item	Range
Supply Voltage	5V \pm 5% (4.5-5.5V)
Standard Temperature	0°C to 70°C
Extended Temperature	-40°C to 85°C

Table 5-2 Absolute Maximum Power Pin Stress Ratings

Parameter	Symbol	Min	Max	Unit
Power Supply Input	VDD- VSS	-0.3	5.5	V
Voltage on any pin except VDD with respect to GND	VIN	-ss - 0.3	VDD +0.3	V

5.2 AC Characteristics

Table 5-3 AC Characteristics Full Speed

Parameter	Symbol	Min	Typ	Max	Unit
Rise Time	T _{FR}	4	—	20	ns
Fall Time	T _{FF}	4	—	20	ns
Differential Rise and Fall Time Matching	T _{FRFM}	90		111.11	%
Driver Output Resistance	Z _{DRV}	28	—	44	Ω

Table 5-4 AC Characteristics High Speed

Parameter	Symbol	Min	Typ	Max	Unit
Rise Time (10%~90%)	T _{HSR}	500	—	—	ps
Fall Time (10%~90%)	T _{HSF}	500	—	—	ps
Driver Output Resistance	Z _{HSDRV}	40.5	—	49.5	Ω

6. Physical Characteristics

6.1 Horizontal Design

6.1.1 Type A (STD 90D)

Standard 90 degree

Length	Width	Height (Max)
28.8mm	26.65mm	10.5 mm

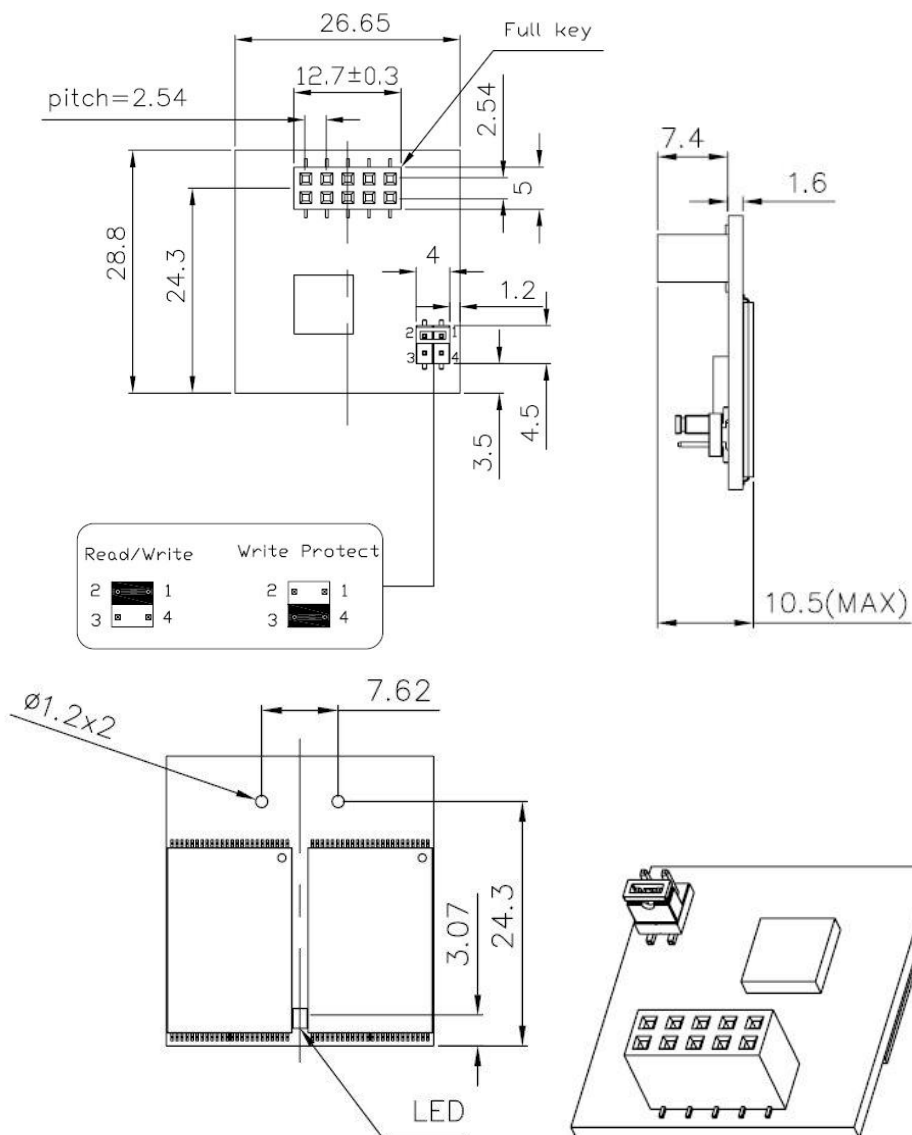

Unit: mm
Tolerance: ±0.2

6.1.2 Type B (STD 90D-MH)

Standard 90 Degree Mounting Header

Length	Width	Height (Max)
37.8mm	26.65mm	10.5 mm

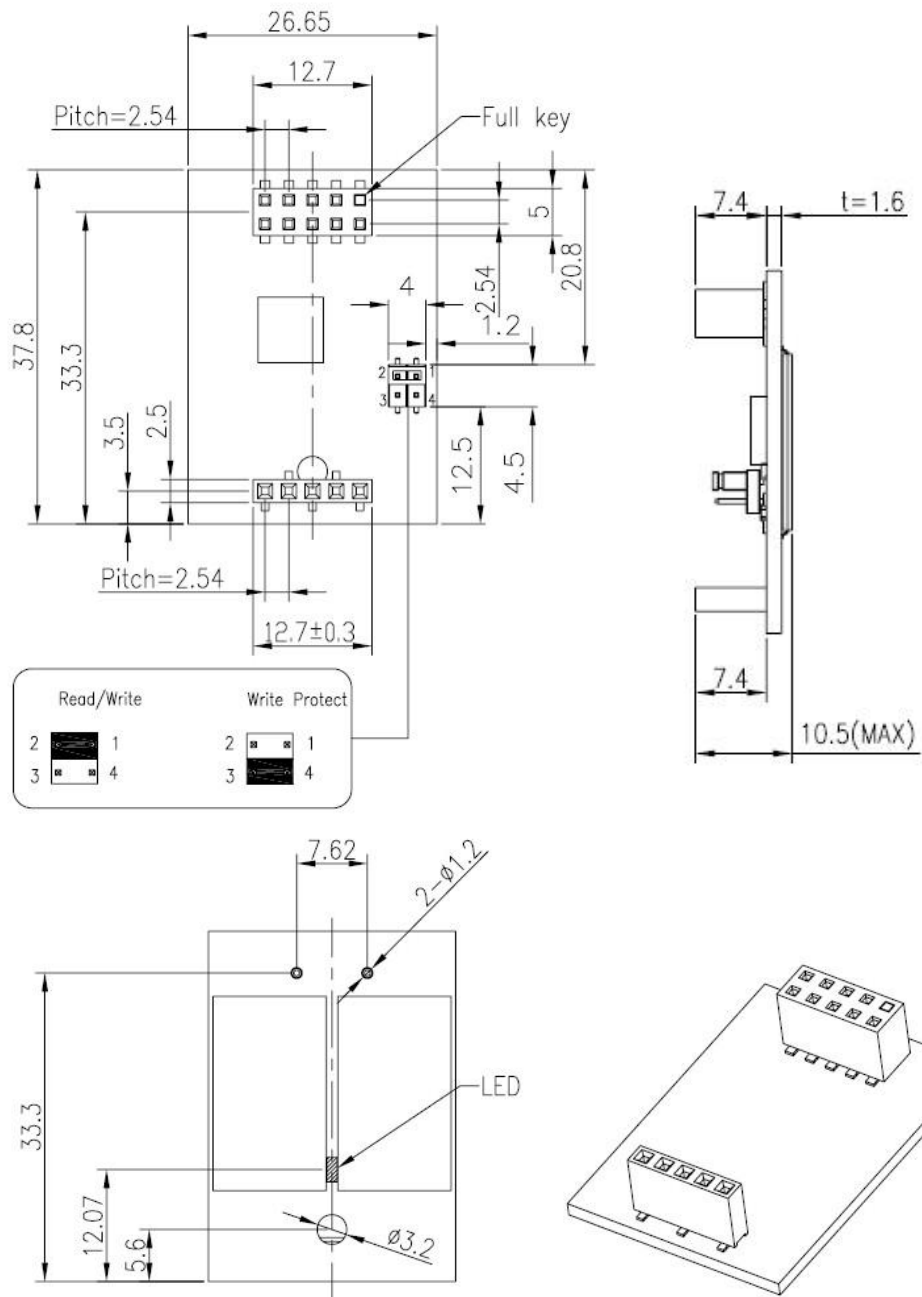

Unit: mm
Tolerance: ± 0.2

6.1.3 Type C (STD 90D-MS)

Standard 90 Degree Mounting Screw

Length	Width	Height (Max)
37.8mm	26.65mm	10.5 mm

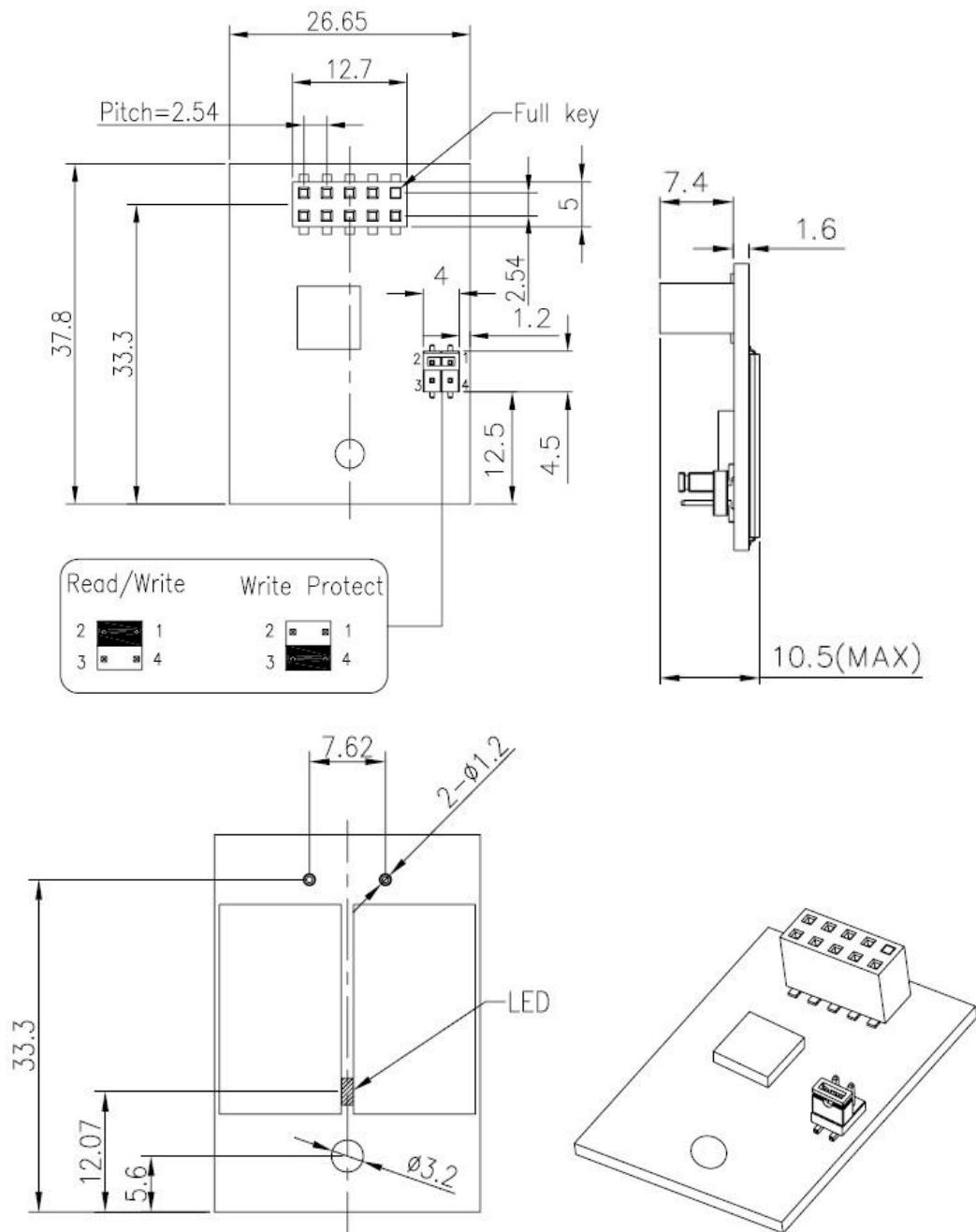

Unit: mm
Tolerance: ±0.2

6.2 Vertical Design

6.2.1 Type D (STD 180D)

Standard 180 Degree

Length	Width	Height (Max)
36.8mm	26.65mm	8.5 mm

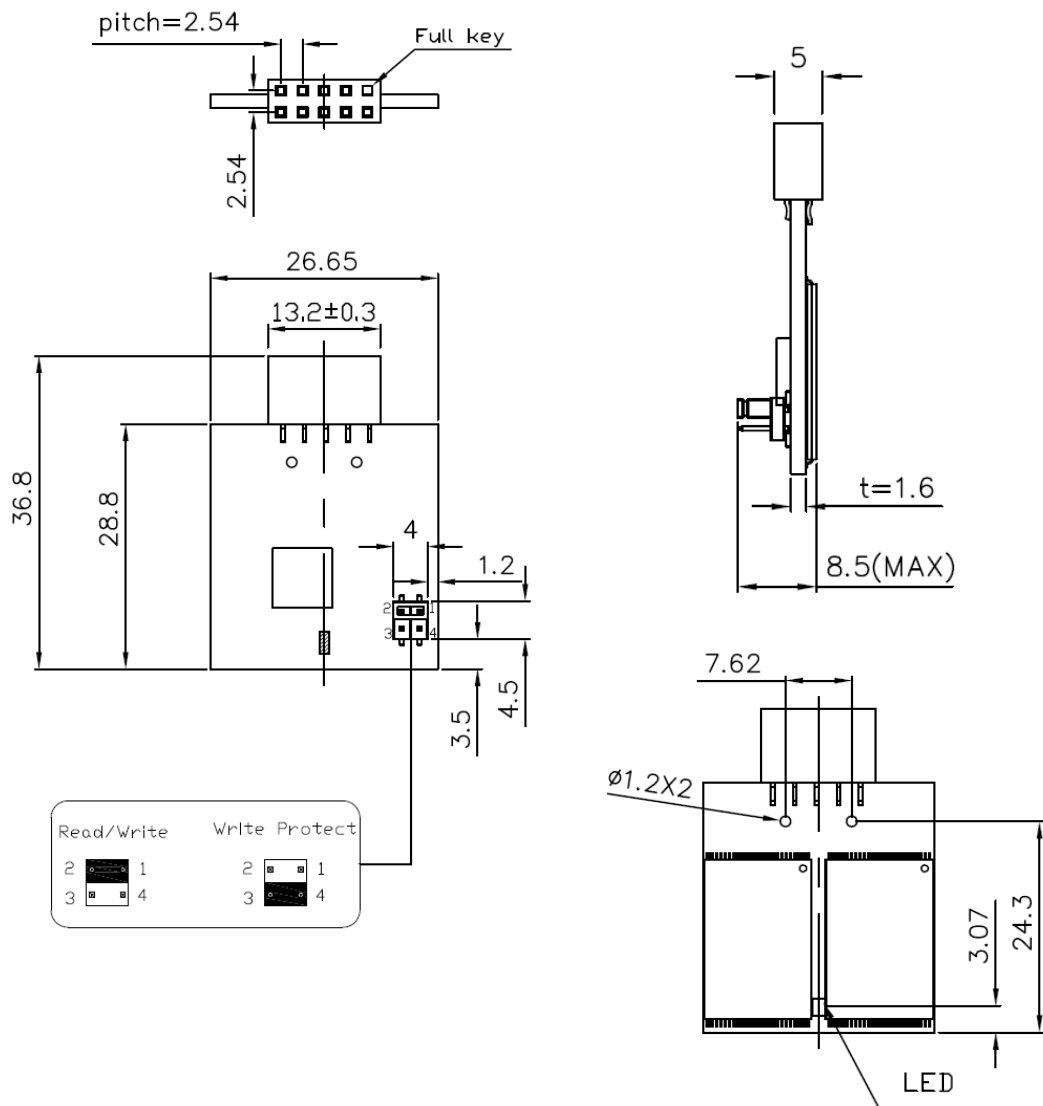

Unit:mm
Tolerance:±0.2

7. Product Ordering Information

7.1 Product Code Designations

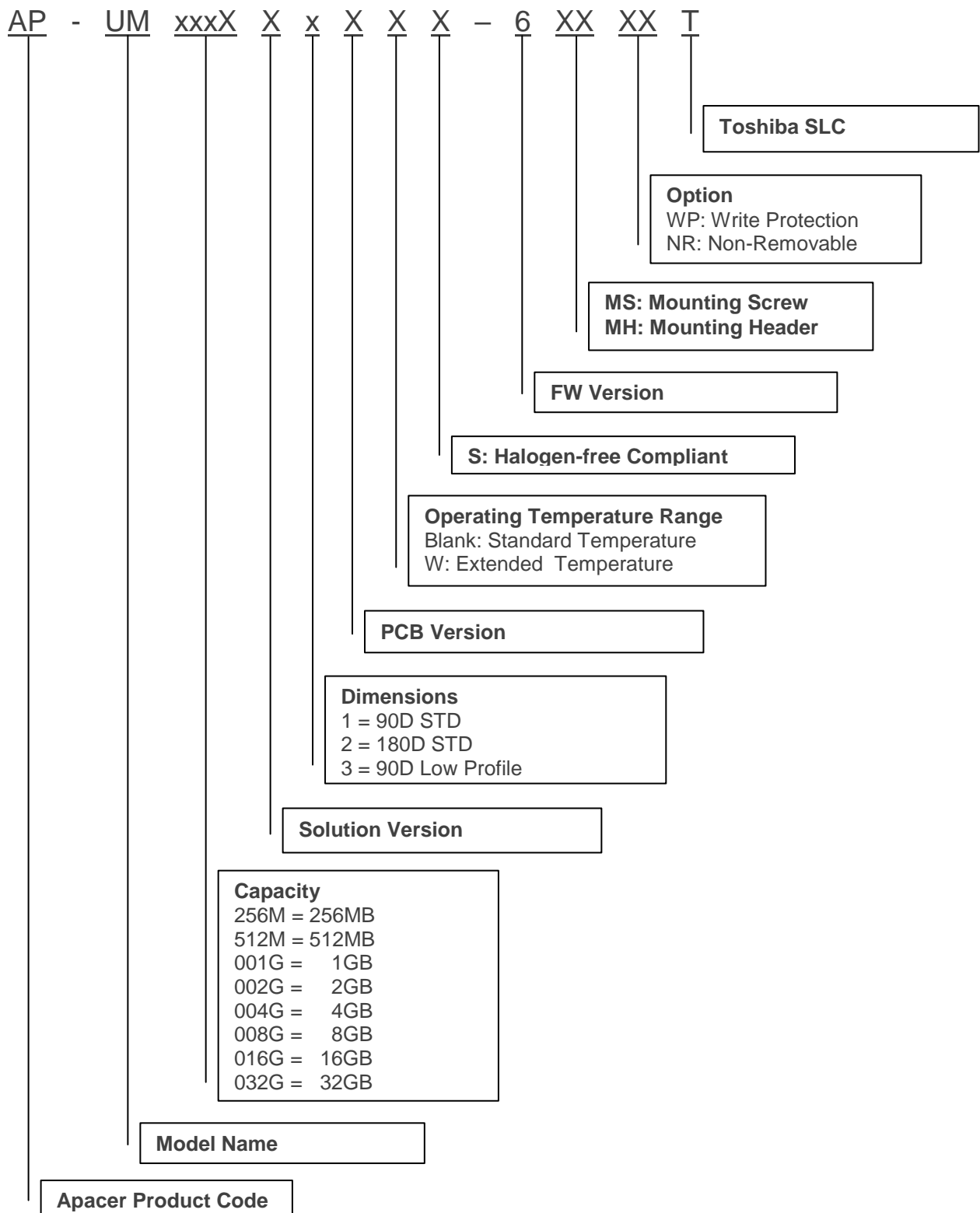

7.2 Valid Combinations

7.2.1 Type A (STD 90D) Standard 90 Degree

Capacity	Standard Temperature	Extended Temperature
256MB	AP-UM256MR13CS-6T	AP-UM256MT13ES-6T
512MB	AP-UM512MR13CS-6T	AP-UM512MT13ES-6T
1GB	AP-UM001GR13CS-6T	AP-UM001GT13ES-6T
2GB	AP-UM002GR13CS-6T	AP-UM002GT13ES-6T
4GB	AP-UM004GR13CS-6T	AP-UM004GT13ES-6T
8GB	AP-UM008GR13CS-6T	AP-UM008GT13ES-6T
16GB	AP-UM016GR13CS-6T	AP-UM016GT13ES-6T
32GB	AP-UM032GR13CS-6T	AP-UM032GT13ES-6T

7.2.2 Type B (STD 90D-MH) Standard 90 Degree Mounting Header

Capacity	Standard Temperature	Extended Temperature
256MB	AP-UM256MR13CS-6MHT	AP-UM256MT13ES-6MHT
512MB	AP-UM512MR13CS-6MHT	AP-UM512MT13ES-6MHT
1GB	AP-UM001GR13CS-6MHT	AP-UM001GT13ES-6MHT
2GB	AP-UM002GR13CS-6MHT	AP-UM002GT13ES-6MHT
4GB	AP-UM004GR13CS-6MHT	AP-UM004GT13ES-6MHT
8GB	AP-UM008GR13CS-6MHT	AP-UM008GT13ES-6MHT
16GB	AP-UM016GR13CS-6MHT	AP-UM016GT13ES-6MHT
32GB	AP-UM032GR13CS-6MHT	AP-UM032GT13ES-6MHT

7.2.3 Type C (STD 90D-MS) Standard 90 Degree Mounting Screw

Capacity	Standard Temperature	Extended Temperature
256MB	AP-UM256MR13CS-6MST	AP-UM256MT13ES-6MST
512MB	AP-UM512MR13CS-6MST	AP-UM512MT13ES-6MST
1GB	AP-UM001GR13CS-6MST	AP-UM001GT13ES-6MST
2GB	AP-UM002GR13CS-6MST	AP-UM002GT13ES-6MST
4GB	AP-UM004GR13CS-6MST	AP-UM004GT13ES-6MST
8GB	AP-UM008GR13CS-6MST	AP-UM008GT13ES-6MST
16GB	AP-UM016GR13CS-6MST	AP-UM016GT13ES-6MST
32GB	AP-UM032GR13CS-6MST	AP-UM032GT13ES-6MST

7.2.4 Type D (STD 180D) Standard 180 Degree

Capacity	Standard Temperature	Extended Temperature
256MB	AP-UM256MR23CS-6T	AP-UM256MT23ES-6T
512MB	AP-UM512MR23CS-6T	AP-UM512MT23ES-6T
1GB	AP-UM001GR23CS-6T	AP-UM001GT23ES-6T
2GB	AP-UM002GR23CS-6T	AP-UM002GT23ES-6T
4GB	AP-UM004GR23CS-6T	AP-UM004GT23ES-6T
8GB	AP-UM008GR23CS-6T	AP-UM008GT23ES-6T
16GB	AP-UM016GR23CS-6T	AP-UM016GT23ES-6T
32GB	AP-UM032GR23CS-6T	AP-UM032GT23ES-6T

7.2.5 Type A (STD 90D) – NR Standard 90 Degree

Capacity	Standard Temperature	Extended Temperature
256MB	AP-UM256MR13CS-6NRT	AP-UM256MT13ES-6NRT
512MB	AP-UM512MR13CS-6NRT	AP-UM512MT13ES-6NRT
1GB	AP-UM001GR13CS-6NRT	AP-UM001GT13ES-6NRT
2GB	AP-UM002GR13CS-6NRT	AP-UM002GT13ES-6NRT
4GB	AP-UM004GR13CS-6NRT	AP-UM004GT13ES-6NRT
8GB	AP-UM008GR13CS-6NRT	AP-UM008GT13ES-6NRT
16GB	AP-UM016GR13CS-6NRT	AP-UM016GT13ES-6NRT
32GB	AP-UM032GR13CS-6NRT	AP-UM032GT13ES-6NRT

7.2.6 Type B (STD 90D-MH) – NR Standard 90 Degree Mounting Header

Capacity	Standard Temperature	Extended Temperature
256MB	AP-UM256MR13CS-6MHNRT	AP-UM256MT13ES-6MHNRT
512MB	AP-UM512MR13CS-6MHNRT	AP-UM512MT13ES-6MHNRT
1GB	AP-UM001GR13CS-6MHNRT	AP-UM001GT13ES-6MHNRT
2GB	AP-UM002GR13CS-6MHNRT	AP-UM002GT13ES-6MHNRT
4GB	AP-UM004GR13CS-6MHNRT	AP-UM004GT13ES-6MHNRT
8GB	AP-UM008GR13CS-6MHNRT	AP-UM008GT13ES-6MHNRT
16GB	AP-UM016GR13CS-6MHNRT	AP-UM016GT13ES-6MHNRT
32GB	AP-UM032GR13CS-6MHNRT	AP-UM032GT13ES-6MHNRT

7.2.7 Type C (STD 90D-MS) – NR Standard 90 Degree Mounting Screw

Capacity	Standard Temperature	Extended Temperature
256MB	AP-UM256MR13CS-6MSNRT	AP-UM256MT13ES-6MSNRT
512MB	AP-UM512MR13CS-6MSNRT	AP-UM512MT13ES-6MSNRT
1GB	AP-UM001GR13CS-6MSNRT	AP-UM001GT13ES-6MSNRT
2GB	AP-UM002GR13CS-6MSNRT	AP-UM002GT13ES-6MSNRT
4GB	AP-UM004GR13CS-6MSNRT	AP-UM004GT13ES-6MSNRT
8GB	AP-UM008GR13CS-6MSNRT	AP-UM008GT13ES-6MSNRT
16GB	AP-UM016GR13CS-6MSNRT	AP-UM016GT13ES-6MSNRT
32GB	AP-UM032GR13CS-6MSNRT	AP-UM032GT13ES-6MSNRT

7.2.8 Type D (STD 180D) – NR Standard 180 Degree

Capacity	Standard Temperature	Extended Temperature
256MB	AP-UM256MR23CS-6NRT	AP-UM256MT23ES-6NRT
512MB	AP-UM512MR23CS-6NRT	AP-UM512MT23ES-6NRT
1GB	AP-UM001GR23CS-6NRT	AP-UM001GT23ES-6NRT
2GB	AP-UM002GR23CS-6NRT	AP-UM002GT23ES-6NRT
4GB	AP-UM004GR23CS-6NRT	AP-UM004GT23ES-6NRT
8GB	AP-UM008GR23CS-6NRT	AP-UM008GT23ES-6NRT
16GB	AP-UM016GR23CS-6NRT	AP-UM016GT23ES-6NRT
32GB	AP-UM032GR23CS-6NRT	AP-UM032GT23ES-6NRT

Note: Valid combinations are those products in mass production or will be in mass production. Consult your Apacer sales representative to confirm availability of valid combinations and to determine availability of new combinations.

Revision History

Revision	Description	Date
1.0	Official Release	May 16, 2011
1.1	Revised Capacity Specifications	May 24, 2011
1.2	Revised Product Ordering Information Updated address for our branch in Europe	April 10 th , 2012
1.3	Added MTBF section	May 10 th , 2012
1.4	Added Non-removable model types into Product Ordering Information	June 20 th , 2012
1.5	Added 16GB & 32GB models	June 29 th , 2012
1.6	Updated Type-E mechanical diagram	July 18 th , 2012
1.7	Updated contact phone number of Apacer office in America	August 30 th , 2012
1.8	Added Write Protect switch to Type E mechanical drawing	February 20 th , 2013
1.9	Added Write Protect for 180D low profile and non-removable type in Product Ordering Information	March 4 th , 2013
2.0	Revised wear-leveling contents: from dynamic to advanced due to firmware upgrade	April 11 th , 2013
2.1	Updated performance due to change of NAND flash use	July 26 th , 2013
2.2	Revised Type D –LP mechanical drawing	June 10 th , 2014
2.3	- Updated “Intelligent USB Module” on Features page - Added 1.1.4 S.M.A.R.T. section - Updated product ordering information	January 12 th , 2017
2.4	- Removed Type E support - Updated 4GB performance and power consumption values	March 7 th , 2017
2.5	- Updated Intelligent USB Module on Features page - Removed support of Ready Boost for Vista - Updated functional block diagram - Removed Type D (LP) pin assignment - Updated 4GB capacity specifications - Removed low profile design mechanical specifications - Updated product ordering information	March 22 nd , 2017
2.6	Updated mechanical specifications for Type D (STD 180D)	March 23 rd , 2017
2.7	Updated 512MB capacity specifications	October 17 th , 2017

Global Presence

Taiwan (Headquarters)

Apacer Technology Inc.

1F., No.32, Zhongcheng Rd., Tucheng Dist.,
New Taipei City 236, Taiwan R.O.C.
Tel: 886-2-2267-8000
Fax: 886-2-2267-2261
amtsales@apacer.com

U.S.A.

Apacer Memory America, Inc.

46732 Lakeview Blvd., Fremont, CA 94538
Tel: 1-408-518-8699
Fax: 1-510-249-9551
sa@apacerus.com

Japan

Apacer Technology Corp.

5F, Matsura Bldg., Shiba, Minato-Ku
Tokyo, 105-0014, Japan
Tel: 81-3-5419-2668
Fax: 81-3-5419-0018
jpservices@apacer.com

Europe

Apacer Technology B.V.

Science Park Eindhoven 5051 5692 EB Son,
The Netherlands
Tel: 31-40-267-0000
Fax: 31-40-290-0686
sales@apacer.nl

China

Apacer Electronic (Shanghai) Co., Ltd

Room D, 22/FL, No.2, Lane 600, JieyunPlaza,
Tianshan RD, Shanghai, 200051, China
Tel: 86-21-6228-9939
Fax: 86-21-6228-9936
sales@apacer.com.cn

India

Apacer Technologies Pvt Ltd,

Unit No.201, "Brigade Corner", 7th Block
Jayanagar,
Yediyur Circle, Bangalore – 560082, India
Tel: 91-80-4152-9061
Fax: 91-80-4170-0215
sales_india@apacer.com