

RoHS Compliant

USB-Disk Module II Plus

Product Specifications

August 17, 2016

Version 1.8



Apacer Technology Inc.

1F, No.32, Zhongcheng Rd., Tucheng Dist., New Taipei City, Taiwan, R.O.C

Tel: +886-2-2267-8000 Fax: +886-2-2267-2261

www.apacer.com

FEATURES:

- **USB2.0 High-Speed and USB1.1 Full-Speed compatible interface**
- **Capacity**
 - 256, 512 MB
 - 1, 2, 4, 8, 16, 32 GB
- **Performance***
 - Sustained read: up to 31 MB/s
 - Sustained write: up to 25 MB/s
- **Intelligent USB Module**
 - Implements dynamic wear-leveling algorithms to substantially increase longevity of flash media
 - BCH (24 bit) Error Detection Code/Error Correction Code (EDC/ECC)
 - Intrinsic data integrity after power loss
 - Wear leveling algorithm that provides more reliable data storage over an extended period
- **Extended Data Protection (Optional)**
 - Write protection setting by jumper for prevention of data overwrites
- **MTBF**
 - Approximately greater than 4.20×10^6 hours
- **Support Boot-Up Function for OS**
 - Windows XP Embedded
 - Windows CE
 - Linux
- **Temperature Range**
 - Operating:
 - Standard: 0°C to 70°C
 - Extended: -40°C to 85°C
 - Storage: -40°C to 85°C
- **Power Consumption***
 - Active mode: 181 mA
 - Sleep mode: 450 μ A
 - Operating voltage: 5V (with a certain percentage of tolerance)
- **Connector**
 - 10-pin (2x5) female header
- **NAND Flash type: SLC**
- **Supports Ready Boost for Vista**
- **RoHS Compliant**
- **Support Non-Removable Setting**

*Varies from capacities. The results for performance and power consumption addressed here are typical and may vary in real world platforms.

TABLE OF CONTENTS

1. General Description	3
1.1 Performance-Optimized Controller	3
1.1.1 Power Management Unit (PMU)	3
1.1.2 SRAM Buffer	3
1.1.3 Error Correction Code (ECC)	3
1.1.4 Wear-Leveling	3
1.1.5 Write Protection Mode (Optional)	3
2. Functional Block Diagram.....	4
3. Pin Assignment.....	5
3.1 Type A, Type B, and Type C	5
3.2 Type D (STD)	6
3.3 Type D (LP)	7
3.4 Type E (LP)	8
4. Performance & Reliability Specifications	9
4.1 Capacity Specifications	9
4.2 Performance Specifications	9
4.3 Environmental Specifications	9
4.4 MTBF	10
5. Electrical Specifications.....	11
5.1 AC Characteristics	11
6. Physical Dimensions	12
6.1 Horizontal Design	12
6.1.1 Type A (STD 90D).....	12
6.1.2 Type B (STD 90D-MH).....	13
6.1.3 Type C (STD 90D-MS).....	14
6.2 Vertical Design	15
6.2.1 Type D (STD 180D).....	15
6.3 Low Profile Design.....	16
6.3.1 Type D (LP 180D)	16
6.3.2 Type E (LP 90D)	17
7. Product Ordering Information.....	18
7.1 Product Code Designation	18
7.2 Valid Combinations.....	19

1. General Description

Apacer's USB-Disk Module (UDM) is a high performance, embedded solid state drive (SSD) designed to replace a conventional IDE hard disk drive. UDM SSD can be plugged into a standard Embedded USB connector commonly found in desktops, portable PC systems and industrial PC systems. This product is well suited for embedded flash storage applications offering new and expanded functionality as well as more cost-effective designs, better performance and increased reliability.

1.1 Performance-Optimized Controller

The heart of an UDM is the USB controller, which translates standard USB signals into the data and controls of the flash media. This proprietary USB controller is specifically designed to attain high data throughput from host to flash.

1.1.1 Power Management Unit (PMU)

The power management unit (PMU) controls the power consumption of the UDM. It can dramatically extend product battery life by leaving the idle part of the circuitry into sleep mode. The PMU has zero wake-up latency.

1.1.2 SRAM Buffer

The SRAM buffer is a key contributor to the USB controller performance. It optimizes data writes to the flash.

1.1.3 Error Correction Code (ECC)

The UDM uses BCH Error Detection Code (EDC) and Error Correction Code (ECC) algorithms which correct up to 24 random single-bit errors for each 1024-byte block of data depending on spare area of flash memory. High performance is achieved through hardware-based error detection and correction.

1.1.4 Wear-Leveling

Flash memory can be erased a limited number of times, This number is called the erase cycle limit, or write endurance limit, The erase cycle limit applies to each individual erase block in the flash device.

In a typical application, and especially if a file system is used, specific pages are constantly updated (e.g., the page that contains the FAT, registry, etc.). Without any special handling, these pages would wear out more rapidly than other pages, reducing the lifetime of the entire flash.

To overcome this inherent deficiency, Apacer's USB-Disk Module (UDM) uses wear-leveling algorithm. This wear-leveling algorithm ensures that consecutive writes of a specific sector are not written physically to the same page in the flash. This spreads flash media usage evenly across all pages, thereby maximizing flash lifetime.

The wear-leveling mechanism provides write/erase cycles for reliable data storage over an extended period.

1.1.5 Write Protection Mode (Optional)

When the device is configured to the Write-Protection mode, it enhances the data security and protection. This feature prevents the stored data from inadvertent system writes or erases, and viruses.

2. Functional Block Diagram

The USB-Disk Module (UDM) contains a controller, embedded firmware, and Flash Media with a female connector. The UDM interfaces with the host system allowing data to be written to and read from the Flash Media.

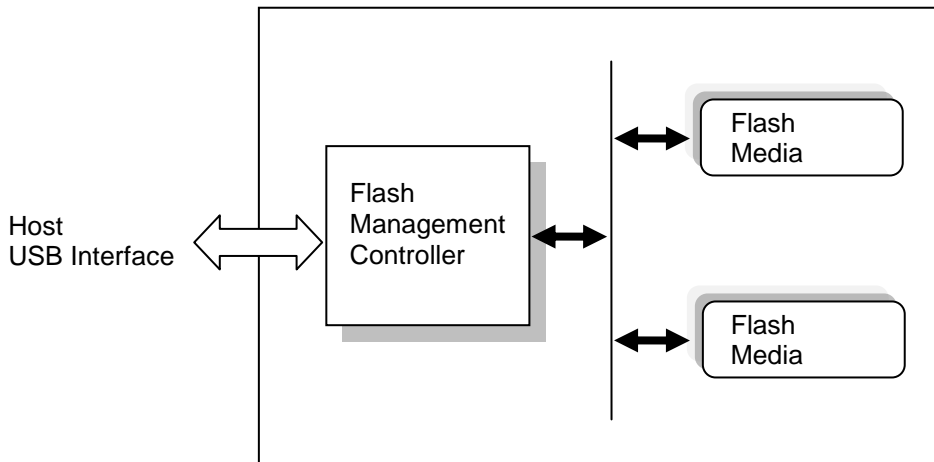

Figure 2-1: Functional block diagram

3. Pin Assignment

This chapter provides the information on the pin assignments and signal descriptions.

3.1 Type A, Type B, and Type C

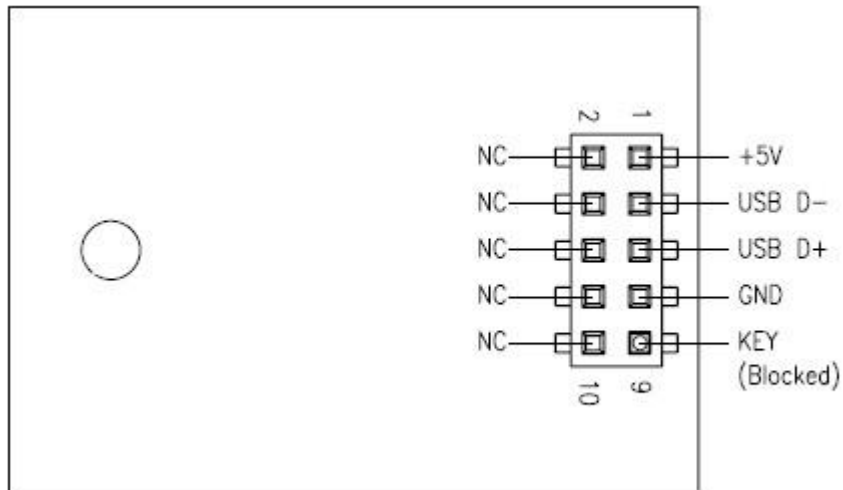

Table 3-1: Pin Assignment of the 10-pin configuration in Type A, Type B, Type C, and Type E

Pin	Signal	Pin	Signal
1	+5V	2	N.C
3	USB D-	4	N.C
5	USB D+	6	N.C
7	GND	8	N.C
9	Key (Blocked)	10	N.C

3.2 Type D (STD)

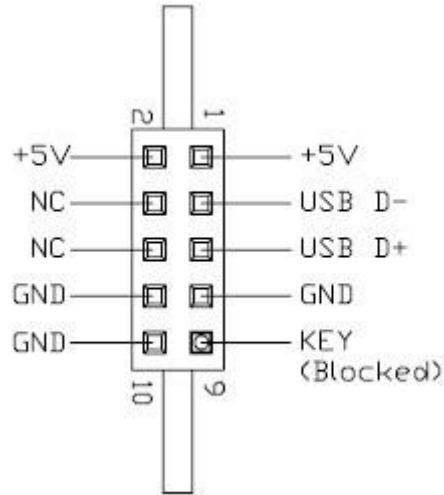

Table 3-2: Pin Assignment of the 10-pin configuration in Type D (STD)

Pin	Signal	Pin	Signal
1	+5V	2	+5V
3	USB D-	4	N.C
5	USB D+	6	N.C
7	GND	8	GND
9	Key (Blocked)	10	GND

3.3 Type D (LP)

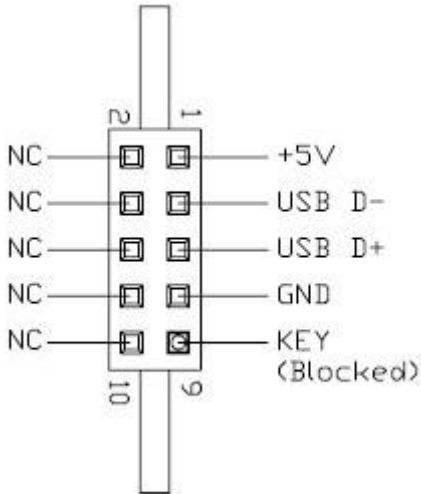

Table 3-3: Pin Assignment of the 10-pin configuration in Type D (LP)

Pin	Signal	Pin	Signal
1	+5V	2	N.C
3	USB D-	4	N.C
5	USB D+	6	N.C
7	GND	8	N.C
9	Key (Blocked)	10	N.C

3.4 Type E (LP)

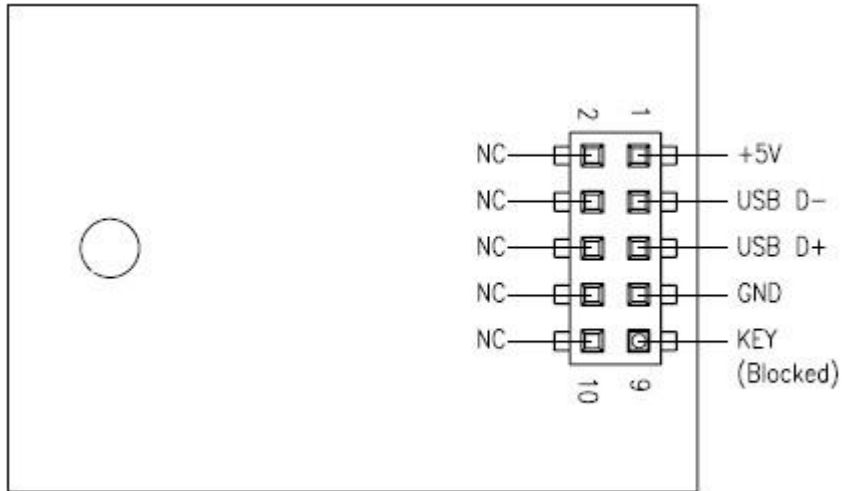

Table 3-4: Pin Assignment of the 10-pin configuration in Type A, Type B, Type C, and Type E

Pin	Signal	Pin	Signal
1	+5V	2	N.C
3	USB D-	4	N.C
5	USB D+	6	N.C
7	GND	8	N.C
9	Key (Blocked)	10	N.C

4. Performance & Reliability Specifications

4.1 Capacity Specifications

The USB-Disk Module product family is available as below table matrix.

Table 4-1: Capacity Specifications

Density	Total Bytes
256MB	254,509,056
512 MB	512,458,752
1GB	1,028,358,144
2GB	2,060,156,928
4GB	4,120,920,064
8GB	8,248,131,584
16GB	16,030,662,656
32GB	32,065,486,848

Notes: the number of total bytes may vary depending on the file system in use.

4.2 Performance Specifications

Table 4-2: Performance Specifications

Capacity	256 MB	512 MB / 1 GB	2 GB	4 GB	8 GB	16 GB	32 GB
Sustained read (MB/s)	15	25	25	30	25	31	31
Sustained write (MB/s)	9	10	15	25	20	21	21

Note: results may vary in real world platforms or flash configurations.

4.3 Environmental Specifications

Environmental specification of the USB-Disk Module (UDM) product family which follows the MIL-STD-810F standards is available as shown in Table 4-3.

Table 4-3: Environmental Specifications

Temperature	Operation	0°C to 70°C (Std.); -40°C to 85°C (Ext. Temp.)
	Storage	-40°C to 85°C
Vibration	Sine wave 10 Hz to 500 Hz, 50 m/s ² , 3 axes (IEC 68-2-6, non-operating)	
Shock	Half sine wave 50G, 6 axes, 18 times (IEC 68-2-27, non-operating)	
EMC	FCC, CE	

4.4 MTBF

Mean Time Between Failures (MTBF) is predicted based on reliability data for the individual components in this device. The measurement assumes that device failure rate can be generated by the sum of failure rates in each component and a steady state failure rate can be predicated as equal to or greater than 4.20×10^6 hours.

Note: The MTBF is predicated and calculated based on "Bellcore Analysis Method 1".

$$\lambda_{SS} = \pi_E \sum_{i=1}^m (Ni\lambda_{SSi})$$

m : number of component types

λ_{SS} : device failure rate at steady state

Ni : quantity of i type component

λ_{SSi} : failure rate for i type component at steady state

π_E : device environment factor

5. Electrical Specifications

Caution: Absolute Maximum Stress Ratings – Applied conditions greater than those listed under “Absolute Maximum Stress Ratings” may cause permanent damage to the device. This is a stress rating only and functional operation of the device at these conditions or conditions greater than those defined in the operational sections of this data sheet is not implied. Exposure to absolute maximum stress rating conditions may affect device reliability.

Table 5-1: Operating Range

Range	Ambient Temperature	Voltage
Standard	0°C to 70°C	4.5-5.5V
Extended Temperature	-40°C to 85°C	

Table 5-2: Absolute maximum power pin stress ratings

Parameter	Symbol	Min	Max	Unit
Power Supply Input	VDD- VSS	-0.3	5.5	V
Voltage on any pin except VDD with respect to GND	VIN	-ss - 0.3	VDD +0.3	V

5.1 AC Characteristics

Table 5-3: AC Characteristics Full Speed

Parameter	Symbol	Min	Typ	Max	Unit
Rise Time	T _{FR}	4	—	20	ns
Fall Time	T _{FF}	4	—	20	ns
Differential Rise and Fall Time Matching	T _{FRFM}	90	—	111.11	%
Driver Output Resistance	Z _{DRV}	28	—	44	Ω

Table 5-4: AC Characteristics High Speed

Parameter	Symbol	Min	Typ	Max	Unit
Rise Time (10%~90%)	T _{HSR}	500	—	—	ps
Fall Time (10%~90%)	T _{HSF}	500	—	—	ps
Driver Output Resistance	Z _{HSDRV}	40.5	—	49.5	Ω

USB-Disk Module II Plus AP-UMxxxxXXXX-XXXX



6.1.3 Type C (STD 90D-MS)

Standard 90 Degree Mounting Screw

Length	37.8mm	Width	26.65mm	Height (Max)	10.5 mm
---------------	--------	--------------	---------	---------------------	---------

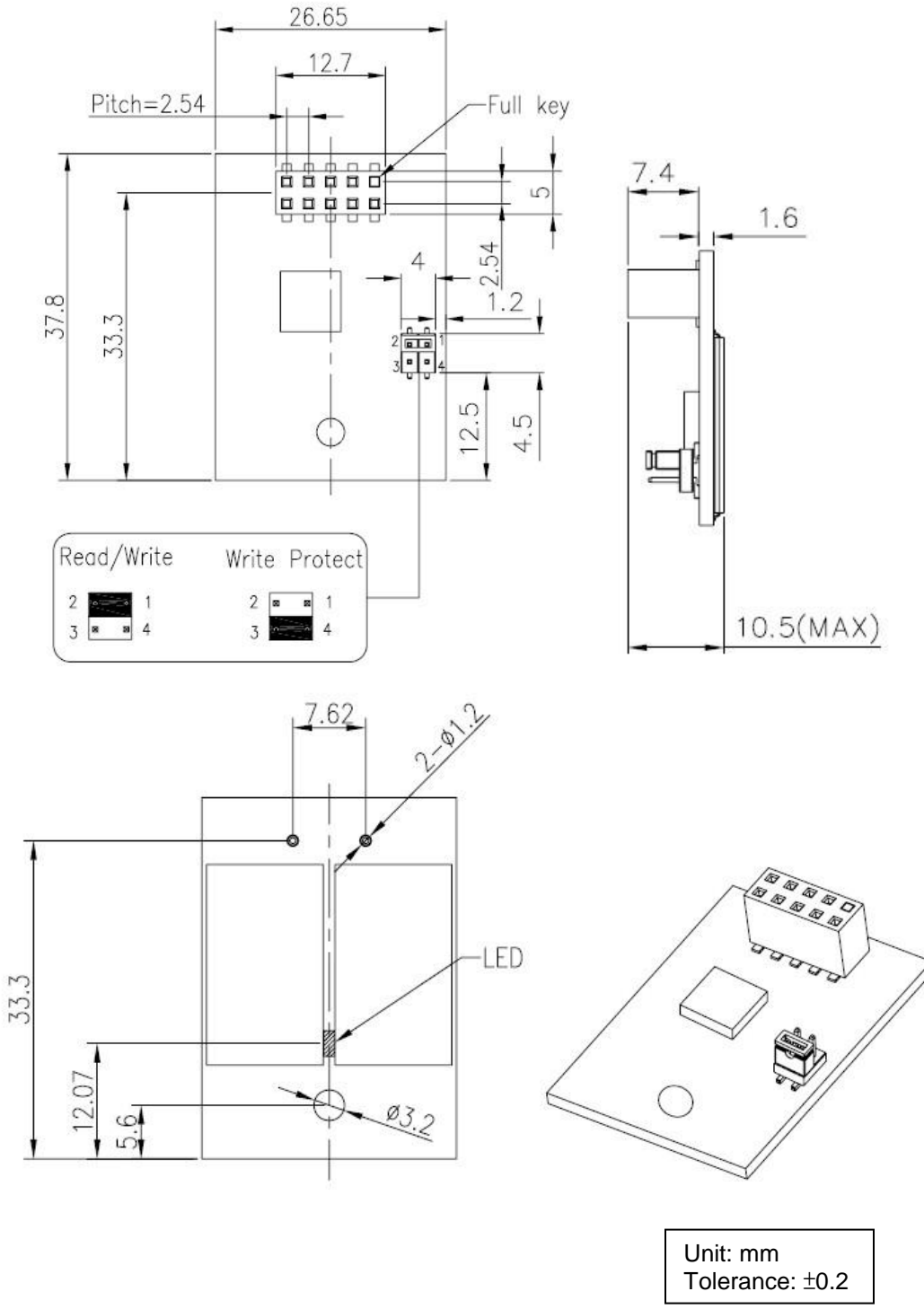

6.3 Low Profile Design

6.3.1 Type D (LP 180D)

Low Profile 180 Degree

Length	31.95 _{mm}	Width	24 _{mm}	Height (Max)	5 _{mm}
---------------	---------------------	--------------	------------------	---------------------	-----------------

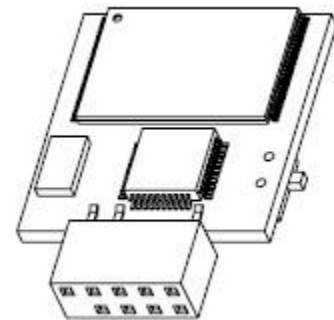
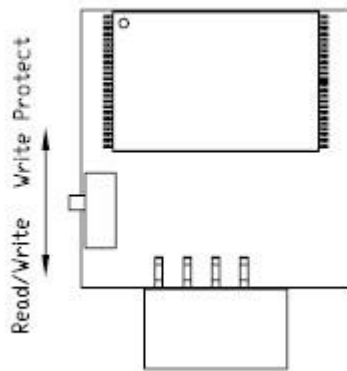
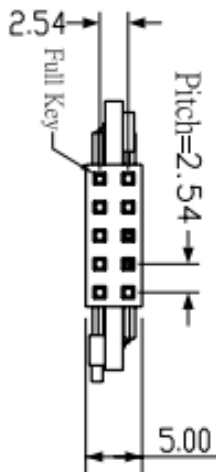
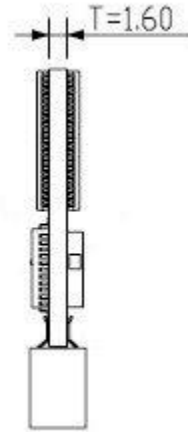
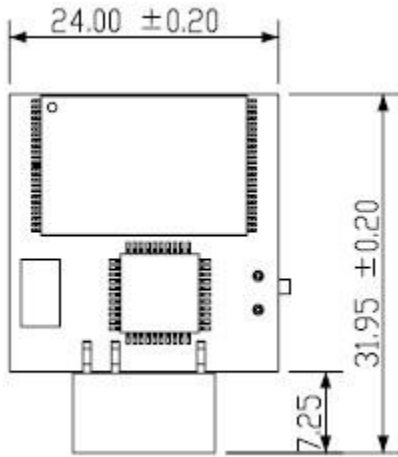

Unit: mm
 Tolerance: ±0.2

USB-Disk Module II Plus AP-UMxxxxXXXXX-XXXXX



6.3.2 Type E (LP 90D)

Low Profile 90 Degree

Length	36.80 _{mm}	Width	26.50 _{mm}	Height (Max)	7.10 _{mm}
---------------	---------------------	--------------	---------------------	---------------------	--------------------

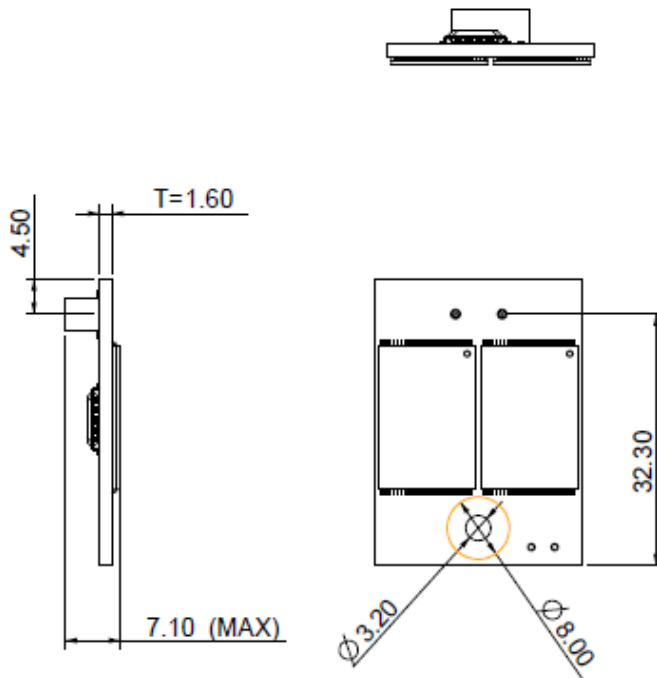
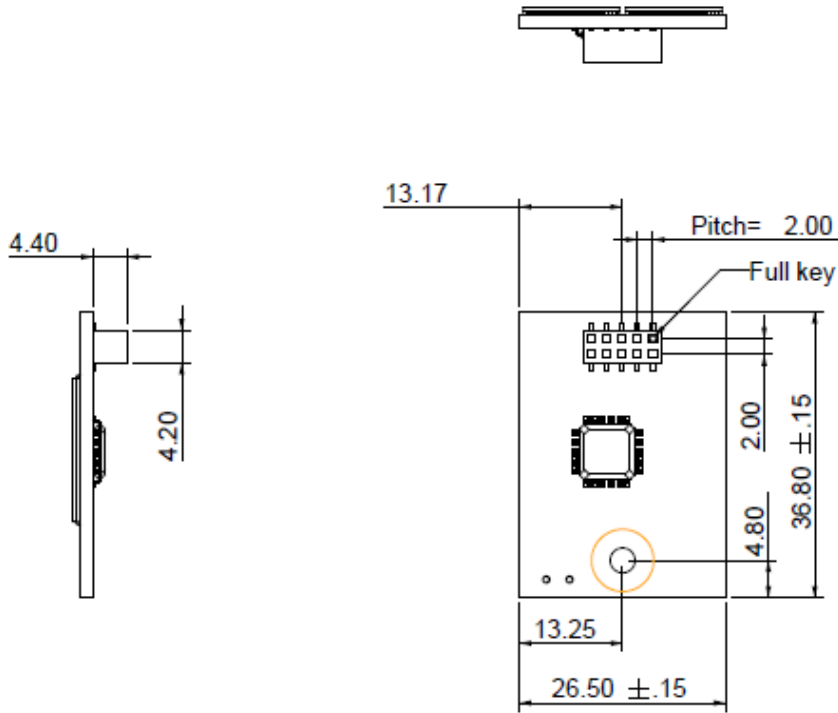

Unit: mm
Tolerance: ±0.2

7. Product Ordering Information

7.1 Product Code Designation

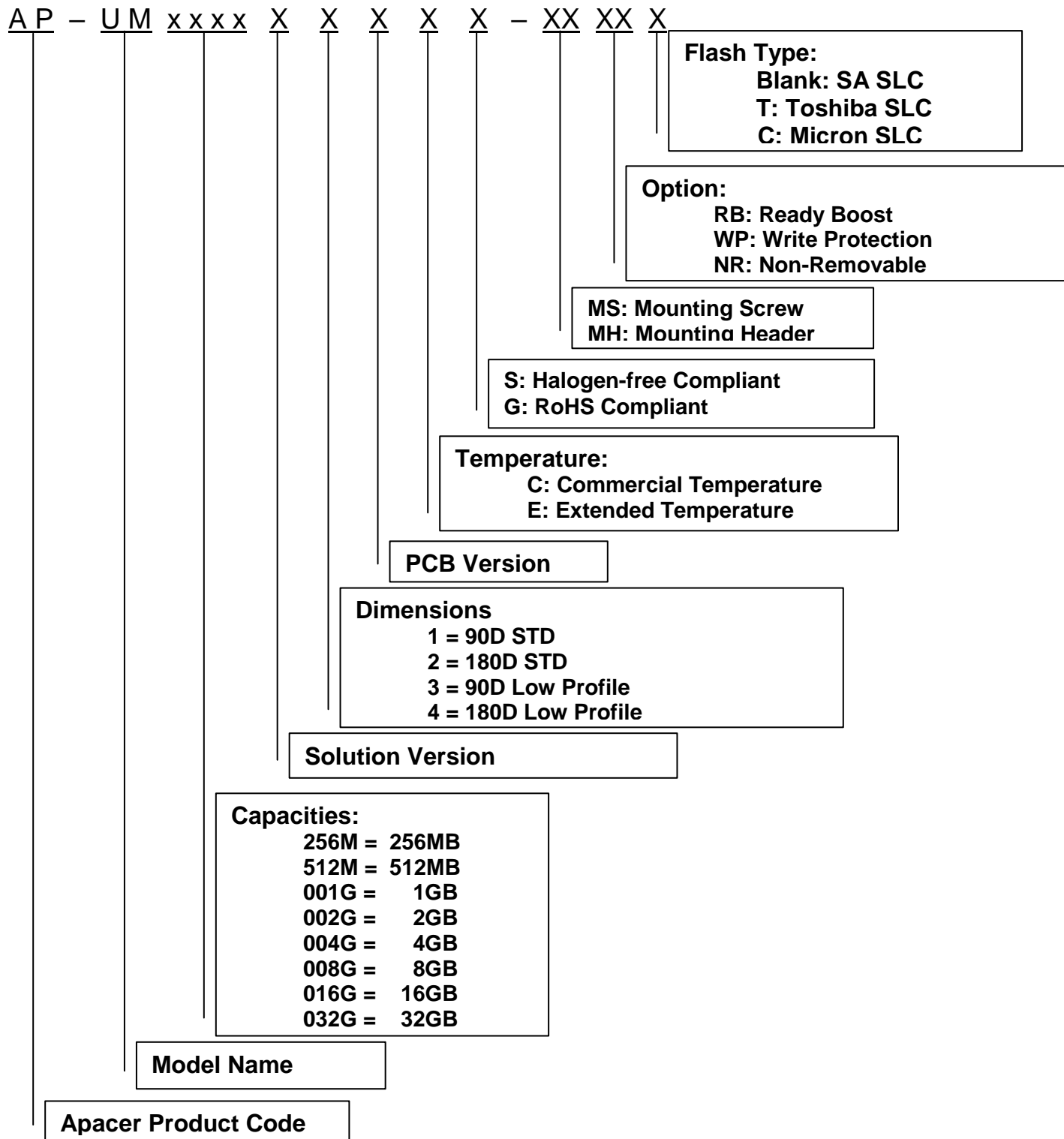

7.2 Valid Combinations

7.2.1 Type A (STD 90D)

Standard 90 degree

Capacity	Standard	Extended Temperature
256MB	AP-UM256MN10CS	AP-UM256MQ10ES
512MB	AP-UM512MN10CS	AP-UM512MQ10ES
1GB	AP-UM001GN10CS	AP-UM001GQ10ES
2GB	AP-UM002GN10CS	AP-UM002GQ10ES
4GB	AP-UM004GN10CS	AP-UM004GQ10ES
8GB	AP-UM008GN10CS-T	AP-UM008GQ10ES-T
16GB	AP-UM016GR13CS-C	AP-UM016GT13ES-C
32GB	AP-UM032GR13CS-C	AP-UM032GT13ES-C

7.2.2 Type B (STD 90D-MH)

Standard 90 degree Mounting Header

Capacity	Standard	Extended Temperature
256MB	AP-UM256MN10CS-MH	AP-UM256MQ10ES-MH
512MB	AP-UM512MN10CS-MH	AP-UM512MQ10ES-MH
1GB	AP-UM001GN10CS-MH	AP-UM001GQ10ES-MH
2GB	AP-UM002GN10CS-MH	AP-UM002GQ10ES-MH
4GB	AP-UM004GN10CS-MH	AP-UM004GQ10ES-MH
8GB	AP-UM008GN10CS-MHT	AP-UM008GQ10ES-MHT
16GB	AP-UM016GR13CS-MHC	AP-UM016GT13ES-MHC
32GB	AP-UM032GR13CS-MHC	AP-UM032GT13ES-MHC

7.2.3 Type C (STD 90D-MS)

Standard 90 degree Mounting Screw

Capacity	Standard	Extended Temperature
256MB	AP-UM256MN10CS-MS	AP-UM256MQ10ES-MS
512MB	AP-UM512MN10CS-MS	AP-UM512MQ10ES-MS
1GB	AP-UM001GN10CS-MS	AP-UM001GQ10ES-MS
2GB	AP-UM002GN10CS-MS	AP-UM002GQ10ES-MS
4GB	AP-UM004GN10CS-MS	AP-UM004GQ10ES-MS
8GB	AP-UM008GN10CS-MST	AP-UM008GQ10ES-MST
16GB	AP-UM016GR13CS-MS	AP-UM016GT13ES-MS
32GB	AP-UM032GR13CS-MS	AP-UM032GT13ES-MS

7.2.4 Type D (STD 180D)

Standard 180 degree

Capacity	Standard	Extended Temperature
256MB	AP-UM256MN20CS	AP-UM256MQ20ES
512MB	AP-UM512MN20CS	AP-UM512MQ20ES
1GB	AP-UM001GN20CS	AP-UM001GQ20ES
2GB	AP-UM002GN20CS	AP-UM002GQ20ES
4GB	AP-UM004GN20CS	AP-UM004GQ20ES
8GB	AP-UM008GN20CS-T	AP-UM008GQ20ES-T
16GB	AP-UM016GR23CS-C	AP-UM016GT23ES-C
32GB	AP-UM032GR23CS-C	AP-UM032GT23ES-C

7.2.5 Type D (LP 180D)

Low Profile 180 Degree

Capacity	Standard	Extended Temperature
256MB	AP-UM256MN40CG	AP-UM256MQ40EG
512MB	AP-UM512MN40CG	AP-UM512MQ40EG
1GB	AP-UM001GN40CG	AP-UM001GQ40EG
2GB	AP-UM002GN40CG	AP-UM002GQ40EG
4GB	AP-UM004GN40CG	AP-UM004GQ40EG
8GB	AP-UM008GN40CG-T	AP-UM008GQ40EG-T

7.2.6 Type E (LP 90D-MS)

Low Profile 90 Degree Mounting Screw

Capacity	Standard	Extended Temperature
256MB	AP-UM256MN31CG-MS	AP-UM256MQ31EG-MS
512MB	AP-UM512MN31CG-MS	AP-UM512MQ31EG-MS
1GB	AP-UM001GN31CG-MS	AP-UM001GQ31EG-MS
2GB	AP-UM002GN31CG-MS	AP-UM002GQ31EG-MS
4GB	AP-UM004GN31CG-MS	AP-UM004GQ31EG-MS
8GB	AP-UM008GN31CG-MST	AP-UM008GQ31EG-MST

USB-Disk Module II Plus

AP-UMxxxxXXXXX-XXXXX



7.2.7 Type A (STD 90D) - NR

Standard 90 degree

Capacity	Standard	Extended Temperature
256MB	AP-UM256MN10CS-NR	AP-UM256MQ10ES-NR
512MB	AP-UM512MN10CS-NR	AP-UM512MQ10ES-NR
1GB	AP-UM001GN10CS-NR	AP-UM001GQ10ES-NR
2GB	AP-UM002GN10CS-NR	AP-UM002GQ10ES-NR
4GB	AP-UM004GN10CS-NR	AP-UM004GQ10ES-NR
8GB	AP-UM008GN10CS-NRT	AP-UM008GQ10ES-NRT
16GB	AP-UM016GR13CS-NRC	AP-UM016GT13ES-NRC
32GB	AP-UM032GR13CS-NRC	AP-UM032GT13ES-NRC

7.2.8 Type B (STD 90D-MH) - NR

Standard 90 degree Mounting Header

Capacity	Standard	Extended Temperature
256MB	AP-UM256MN10CS-MHNR	AP-UM256MQ10ES-MHNR
512MB	AP-UM512MN10CS-MHNR	AP-UM512MQ10ES-MHNR
1GB	AP-UM001GN10CS-MHNR	AP-UM001GQ10ES-MHNR
2GB	AP-UM002GN10CS-MHNR	AP-UM002GQ10ES-MHNR
4GB	AP-UM004GN10CS-MHNR	AP-UM004GQ10ES-MHNR
8GB	AP-UM008GN10CS-MHNRT	AP-UM008GQ10ES-MHNRT
16GB	AP-UM016GR13CS-MHNRC	AP-UM016GT13ES-MHNRC
32GB	AP-UM032GR13CS-MHNRC	AP-UM032GT13ES-MHNRC

7.2.9 Type C (STD 90D-MS) - NR

Standard 90 degree Mounting Screw

Capacity	Standard	Extended Temperature
256MB	AP-UM256MN10CS-MSNR	AP-UM256MQ10ES-MSNR
512MB	AP-UM512MN10CS-MSNR	AP-UM512MQ10ES-MSNR
1GB	AP-UM001GN10CS-MSNR	AP-UM001GQ10ES-MSNR
2GB	AP-UM002GN10CS-MSNR	AP-UM002GQ10ES-MSNR
4GB	AP-UM004GN10CS-MSNR	AP-UM004GQ10ES-MSNR
8GB	AP-UM008GN10CS-MSNRT	AP-UM008GQ10ES-MSNRT
16GB	AP-UM016GR13CS-MSNRC	AP-UM016GT13ES-MSNRC
32GB	AP-UM032GR13CS-MSNRC	AP-UM032GT13ES-MSNRC

7.2.10 Type D (STD 180D) - NR

Standard 180 degree

Capacity	Standard	Extended Temperature
256MB	AP-UM256MN20CS-NR	AP-UM256MQ20ES-NR
512MB	AP-UM512MN20CS-NR	AP-UM512MQ20ES-NR
1GB	AP-UM001GN20CS-NR	AP-UM001GQ20ES-NR
2GB	AP-UM002GN20CS-NR	AP-UM002GQ20ES-NR
4GB	AP-UM004GN20CS-NR	AP-UM004GQ20ES-NR
8GB	AP-UM008GN20CS-NRT	AP-UM008GQ20ES-NRT
16GB	AP-UM016GR23CS-NRC	AP-UM016GT23ES-NRC
32GB	AP-UM032GR23CS-NRC	AP-UM032GT23ES-NRC

7.2.11 Type D (LP 180D) - NR

Low Profile 180 Degree

Capacity	Standard	Extended Temperature
256MB	AP-UM256MN40CG-NR	AP-UM256MQ40EG-NR
512MB	AP-UM512MN40CG-NR	AP-UM512MQ40EG-NR
1GB	AP-UM001GN40CG-NR	AP-UM001GQ40EG-NR
2GB	AP-UM002GN40CG-NR	AP-UM002GQ40EG-NR
4GB	AP-UM004GN40CG-NR	AP-UM004GQ40EG-NR
8GB	AP-UM008GN40CG-NRT	AP-UM008GQ40EG-NRT

7.2.12 Type E (LP 90D-MS) - NR

Low Profile 90 Degree Mounting Screw

Capacity	Standard	Extended Temperature
256MB	AP-UM256MN31CG-MSNR	AP-UM256MQ31EG-MSNR
512MB	AP-UM512MN31CG-MSNR	AP-UM512MQ31EG-MSNR
1GB	AP-UM001GN31CG-MSNR	AP-UM001GQ31EG-MSNR
2GB	AP-UM002GN31CG-MSNR	AP-UM002GQ31EG-MSNR
4GB	AP-UM004GN31CG-MSNR	AP-UM004GQ31EG-MSNR
8GB	AP-UM008GN31CG-MSNRT	AP-UM008GQ31EG-MSNRT

Note: Valid combinations are sets of part numbers for reference in mass production or will be in mass production. Please availability or customized requests, please consult with our sales representatives.

Revision History

Revision	Description	Date
1.0	Official Release	May 16, 2011
1.1	Revised Capacity Specifications	May 24, 2011
1.2	Revised Product Ordering Information Updated address for our branch in Europe	April 10 th , 2012
1.3	Added MTBF section	May 10 th , 2012
1.4	Added Non-removable model types into Product Ordering Information	June 20 th , 2012
1.5	Added 16GB & 32GB models	June 29 th , 2012
1.6	Updated Type-E mechanical diagram	July 18 th , 2012
1.7	Updated contact phone number of Apacer office in America	August 30 th , 2012
1.8	Revised product ordering information	August 17 th , 2016

Global Presence

Taiwan (Headquarters)	Apacer Technology Inc. 1F., No.32, Zhongcheng Rd., Tucheng Dist., New Taipei City 236, Taiwan R.O.C. Tel: 886-2-2267-8000 Fax: 886-2-2267-2261 amtsales@apacer.com
U.S.A.	Apacer Memory America, Inc. 46732 Lakeview Blvd., Fremont, CA 94538 Tel: 1-408-518-8699 Fax: 1-510-249-9551 sa@apacerus.com
Japan	Apacer Technology Corp. 5F, Matsura Bldg., Shiba, Minato-Ku Tokyo, 105-0014, Japan Tel: 81-3-5419-2668 Fax: 81-3-5419-0018 jpservices@apacer.com
Europe	Apacer Technology B.V. Science Park Eindhoven 5051 5692 EB Son, The Netherlands Tel: 31-40-267-0000 Fax: 31-40-267-0000#6199 sales@apacer.nl
China	Apacer Electronic (Shanghai) Co., Ltd Room D, 22/FL, No.2, Lane 600, JieyunPlaza, Tianshan RD, Shanghai, 200051, China Tel: 86-21-6228-9939 Fax: 86-21-6228-9936 sales@apacer.com.cn
India	Apacer Technologies Pvt. Ltd. Unit No.201, "Brigade Corner", 7 th Block Jayanagar, Yediyur Circle, Bangalore – 560082, India Tel: 91-80-4152-9061 Fax: 91-80-4170-0215 sales_india@apacer.com