

RoHS Recast Compliant

USB Flash Drive

UV110-UFD6 vDrive Product Specifications



September 20, 2022

Version 1.1



Apacer Technology Inc.

1F, No.32, Zhongcheng Rd., Tucheng Dist., New Taipei City, Taiwan, R.O.C

Tel: +886-2-2267-8000 Fax: +886-2-2267-2261

www.apacer.com

Specifications Overview:

- **Compatible with USB 2.0 & USB 1.1 interfaces**
 - Compatible with 480Mb/s for USB 2.0 & 12 Mb/s for USB 1.1
- **Capacity**
 - 8 GB
- **Performance¹**
 - Sequential read: Up to 36 MB/sec
 - Sequential write: Up to 22 MB/sec
 - Random read (4K): Up to 1,200 IOPS
 - Random write (4K): Up to 200 IOPS
- **Flash Management**
 - Built-in hardware Low Density Parity-Check (LDPC) ECC
 - Global Wear Leveling
 - Flash bad-block management
 - Flash Translation Layer: Page Mapping
 - Power Failure Management
 - S.M.A.R.T.
 - Hyper Cache Technology
 - SMART Read Refresh™
- **Supports Non-Removable Setting**
- **Supports Toggle 2.0 mode/ONFI 3.0**
- **NAND Flash Type: 3D TLC (BiCS3)**
- **MTBF: >3,000,000 hours**
- **Endurance (in drive writes per day: DWPD)**
 - 8 GB: 5.48 DWPD
- **Temperature Range**
 - Operating: 0°C to 70°C
 - Storage: -40°C to 100°C
- **Supply Voltage**
 - 5.0 V ± 5%
- **Power Consumption¹**
 - Active mode: 85 mA
 - Idle mode: 65 mA
- **OS Support**
 - Windows: Win7/8/10 later
 - Mac: 10.2.8/10.8 or later
 - Linux: 2.4.0/2.4.10 or later
- **Dimensions**
 - 52.05 x 17.70 x 8.70, unit: mm
- **LED Indicators for Drive Behavior**
- **RoHS Recast Compliant**
 - Complies with 2011/65/EU Standard
- **Customization**
 - Formatted with NTFS 512 byte
 - Drive label presented as vDrive

Note:

1. Varies from capacities. The values for performances and power consumptions presented are typical and may vary depending on flash configurations or platform settings. The term idle refers to the standby state of the device.

Table of Contents

| | |
|---|-----------|
| 1. General Description | 3 |
| 2. Functional Block | 3 |
| 3. Product Specifications..... | 4 |
| 3.1 Capacity (Estimation) | 4 |
| 3.2 Performance | 5 |
| 3.3 Environmental Specifications | 5 |
| 3.4 Mean Time Between Failures (MTBF) | 5 |
| 3.5 Certification and Compliance..... | 5 |
| 3.6 Endurance | 6 |
| 3.7 LED Indicator Behavior..... | 6 |
| 4. Flash Management | 7 |
| 4.1 Performance-optimized USB Controller | 7 |
| 4.2 Power Saving Implemented..... | 7 |
| 4.3 Program RAM Architect..... | 7 |
| 4.4 Error Correction/Detection (ECC)..... | 7 |
| 4.5 Global Wear Leveling | 7 |
| 4.6 S.M.A.R.T. | 8 |
| 4.7 Power Failure Management | 8 |
| 4.8 Bad Block Management | 8 |
| 4.9 Flash Translation Layer – Page Mapping..... | 8 |
| 4.10 Hyper Cache Technology | 9 |
| 4.11 SMART Read Refresh™ | 9 |
| 5. Electrical Specifications..... | 10 |
| 5.1 Absolute Stress Rating | 10 |
| 5.2 Absolute Maximum Rating..... | 10 |
| 5.3 Power Consumption | 11 |
| 6. Mechanical Specifications..... | 12 |
| 7. Product Ordering Information..... | 13 |
| 7.1 Product Code Designations..... | 13 |
| 7.2 Valid Combinations..... | 14 |

1. General Description

Apacer UV110-UFD6 vDrive is a removable flash disk drive with USB interface and capabilities of supporting various storage capacities. Compatible with both USB 1.1 and 2.0 specifications with its plug-and-play nature, UV110-UFD6 vDrive can be easily adopted in any computing system with a USB port. The device can be automatically detected by the host computer so that users can access data to read, write, copy, or move data between host system drive and UV110-UFD6 vDrive, and the status of these operations can be indicated through the use of LED light pipes. No battery, cable, or software driver is required, UV110-UFD6 vDrive is widely compatible with mainstream computer platforms, no matter desktop or laptops, as long as there is an available USB port. UV110-UFD6 vDrive makes data transfer easy, fast and handy.

Utilizing 3D NAND and providing more power efficiency than 2D NAND, UV110-UFD6 is implemented with LDPC (Low Density Parity Check) ECC engine to extend SSD endurance and increase data reliability. In terms of flash management, UV110-UFD6 adopts the latest page mapping file translation layer and comes with various implementations including powerful hardware ECC engine, wear leveling, flash block management, S.M.A.R.T., power failure management, Hyper Cache technology and SMART Read Refresh™. This product is well suited for portable flash storage applications while operating at minimal power consumption.

2. Functional Block

With embedded firmware, Apacer's UV110-UFD6 vDrive contains a controller and flash media with a female connector. It interfaces with the host system allowing data to be written to and read from the flash media.

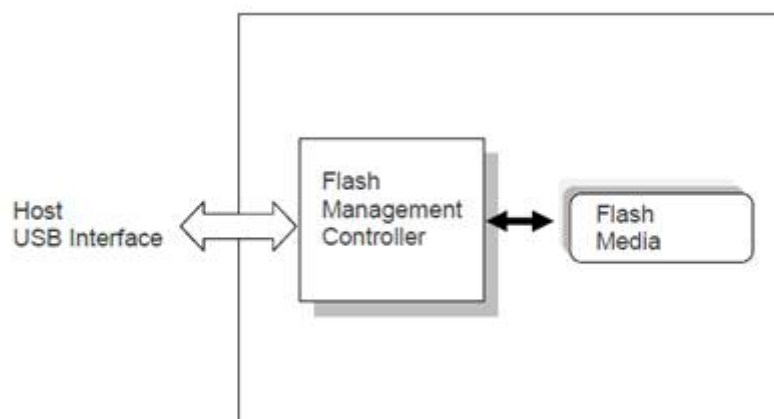

Figure 2-1 Functional Block Diagram

3. Product Specifications

3.1 Capacity (Estimation)

UV110-UFD6 vDrive is customized with the following two configurations as illustrated in Figure 3-1.

1. Formatted with NTFS 512 byte
2. Drive label presented as vDrive

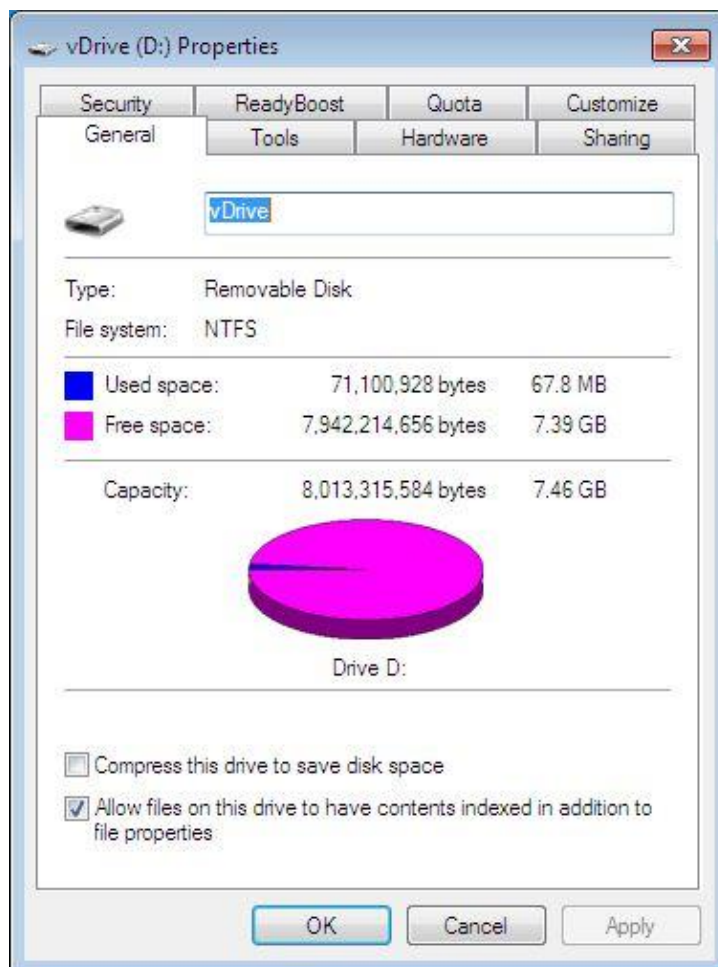

Note: The capacity specified in the figure is based on NTFS files system in Windows 7 and may vary in different operating systems.

Figure 3-1 Customized Configurations

3.2 Performance

Performance of UV110-UFD6 vDrive is listed below in Table 3-1.

Table 3-1 Performance Specifications

| Performance | Capacity | 8 GB |
|-------------------------|----------|-------|
| Sequential Read (MB/s) | | 36 |
| Sequential Write (MB/s) | | 22 |
| Random Read IOPS (4K) | | 1,200 |
| Random Write IOPS (4K) | | 200 |

Notes:

- Results may differ from various flash configurations or host system setting, and the above test results are based on the default file structure with FAT 32 file system.
- Sequential read/write is based on CrystalDiskMark 5.2.1 with file size 1,000MB.
- Random read/write is measured using IOMeter with Queue Depth 32.

3.3 Environmental Specifications

Environmental specifications of UV110-UFD6 vDrive product are shown in Table 3-2.

Table 3-2 Environmental Specifications

| Item | Specifications |
|-------------------------|--|
| Operating temp. | 0°C to 70°C |
| Non-operating temp. | -40°C to 100°C |
| Operating vibration | 7.69 GRMS, 20~2000 Hz/random (compliant with MIL-STD-810G) |
| Non-operating vibration | 4.02 GRMS, 15~2000 Hz/sine (compliant with MIL-STD-810G) |
| Operating shock | 50G, 11ms/half sine (compliant with MIL-STD-202G) |
| Non-operating shock | 1500G, 0.5ms/half sine (compliant with MIL-STD-883K) |

Note: This Environmental Specification table indicates the conditions for testing the device. Real world usages may affect the results.

3.4 Mean Time Between Failures (MTBF)

Mean Time Between Failures (MTBF) is predicted based on reliability data for the individual components in Apacer’s USB flash drive. Serving as statistical reference, the prediction result for Apacer’s UV110-UFD6 vDrive is more than 3,000,000 hours.

Note: The MTBF is predicated and calculated based on “Telcordia Technologies Special Report, SR-332, Issue 3” method.

3.5 Certification and Compliance

UV110-UFD6 vDrive complies with the following standards:

- CE
- FCC
- RoHS Recast Compliant
- MIL-STD-810

3.6 Endurance

The endurance of a storage device is predicted by Drive Writes Per Day based on several factors related to usage, such as the amount of data written into the drive, block management conditions, and daily workload for the drive. Thus, key factors, such as Write Amplifications and the number of P/E cycles, can influence the lifespan of the drive.

Table 3-3 Drive Writes Per Day

| Capacity | Drive Writes Per Day |
|----------|----------------------|
| 8 GB | 5.48 |

Notes:

- This estimation values are based on sequential write behavior. (Apacer EDTestTool, test mode – sequential data pattern -100.00% of disk space with 128K)
- Flash vendor guaranteed 3D NAND TLC P/E cycle: 3K
- WAF may vary from capacity, flash configurations and writing behavior on each platform.
- 1 Terabyte = 1,024GB
- DWPD (Drive Write s Per Day) is calculated based on the number of times that user overwrites the entire capacity of an SSD per day of its lifetime during the warranty period. (3D NAND TLC warranty: 3 years)

3.7 LED Indicator Behavior

The behavior of the UV110-UFD6 vDrive LED indicators is described in Table 3-4.

Table 3-4 LED Behavior

| Location | LED Color | Description |
|--------------------------------------|-----------|--|
| As indicated by the red marker below | Blue | LED blinks when the drive is being accessed such as power on, read or write. The blink frequency is 50ms switch H to L and loop. |



4. Flash Management

4.1 Performance-optimized USB Controller

The heart of UV110-UFD6 vDrive is the USB controller, which translates standard USB signals into the data and controls of the flash media. This proprietary USB controller is specifically designed to attain high data throughput from host to flash.

4.2 Power Saving Implemented

The internal controller of the USB model is designed with power saving implementations, allowing the device to operate at low power consumption.

4.3 Program RAM Architect

The internal Program RAM implementation allows the host to upgrade firmware codes anytime when needed.

4.4 Error Correction/Detection (ECC)

UV110-UFD6 vDrive implements a hardware ECC scheme, based on the Low Density Parity Check (LDPC). LDPC is a class of linear block error correcting code which has apparent coding gain over BCH code because LDPC code includes both hard decoding and soft decoding algorithms. With the error rate decreasing, LDPC can extend SSD endurance and increase data reliability while reading raw data inside a flash chip.

4.5 Global Wear Leveling

Flash memory can be erased a limited number of times, This number is called the erase cycle limit, or write endurance limit, The erase cycle limit applies to each individual erase block in the flash device.

In a typical application, and especially if a file system is used, specific pages are constantly updated (e.g., the page that contains the FAT, registry, etc.). Without any special handling, these pages would wear out more rapidly than other pages, reducing the lifetime of the entire flash.

To overcome this inherent deficiency, Apacer's UV110-UFD6 vDrive uses Global Wear Leveling algorithm. This algorithm ensures that consecutive writes of a specific sector are not written physically to the same page in the flash. This spreads flash media usage evenly across all pages, thereby maximizing flash lifetime.

The Global Wear Leveling mechanism provides write/erase cycles for reliable data storage over an extended period.

4.6 S.M.A.R.T.

S.M.A.R.T. is an abbreviation for Self-Monitoring, Analysis and Reporting Technology, a self-monitoring system that provides indicators of drive health as well as potential disk problems. It serves as a warning for users from unscheduled downtime by monitoring and displaying critical drive information. Ideally, this should allow taking proactive actions to prevent drive failure and make use of S.M.A.R.T. information for future product development reference.

Table 4-1 SMART Attribute ID List

| ID (Hex) | Attribute Name |
|------------|-----------------------------|
| 162 (0xA2) | Spare Block Count |
| 163 (0xA3) | Maximum Erase Count |
| 164 (0xA4) | Average Erase Count |
| 166 (0xA6) | Total Later Bad Block Count |
| 167 (0xA7) | Protect Mode |

4.7 Power Failure Management

Power Failure Management plays a crucial role when power supply becomes unstable. Power disruption may occur when users are storing data into the SSD, leading to instability in the drive. However, with Power Failure Management, a firmware protection mechanism will be activated to scan pages and blocks once power is resumed. Valid data will be transferred to new blocks for merging and the mapping table will be rebuilt. Therefore, data reliability can be reinforced, preventing damage to data stored in the NAND Flash.

4.8 Bad Block Management

Current production technology is unable to guarantee total reliability of NAND flash memory array. When a flash memory device leaves factory, it comes with a minimal number of initial bad blocks during production or out-of-factory as there is no currently known technology that produce flash chips free of bad blocks. In addition, bad blocks may develop during program/erase cycles. Since bad blocks are inevitable, the solution is to keep them in control. Apacer flash devices are programmed with ECC, page mapping technique and S.M.A.R.T to reduce invalidity or error. Once bad blocks are detected, data in those blocks will be transferred to free blocks and error will be corrected by designated algorithms.

4.9 Flash Translation Layer – Page Mapping

Page mapping is an advanced flash management technology whose essence lies in the ability to gather data, distribute the data into flash pages automatically, and then schedule the data to be evenly written. Page-level mapping uses one page as the unit of mapping. The most important characteristic is that each logical page can be mapped to any physical page on the flash memory device. This mapping algorithm allows different sizes of data to be written to a block as if the data is written to a data pool and it does not need to take extra operations to process a write command. Thus, page mapping is adopted to increase random access speed and improve SSD lifespan, reduce block erase frequency, and achieve optimized performance and lifespan.

4.10 Hyper Cache Technology

Apacer proprietary Hyper Cache technology uses a portion of the available capacity as SLC (1bit-per-cell) NAND flash memory, called Hyper cache mode. When data is written to SSD, the firmware will direct the data to Hyper Cache mode, providing excellent performance to handle various scenarios in industrial use.

4.11 SMART Read Refresh™

Apacer's SMART Read Refresh plays a proactive role in avoiding read disturb errors from occurring to ensure health status of all blocks of NAND flash. Developed for read-intensive applications in particular, SMART Read Refresh is employed to make sure that during read operations, when the read operation threshold is reached, the data is refreshed by re-writing it to a different block for subsequent use.

5. Electrical Specifications

5.1 Absolute Stress Rating

Table 5-1 lists the absolute stress rating for UV110-UFD6 vDrive.

Caution: Absolute Maximum Stress Ratings – Applied conditions greater than those listed under “Absolute Maximum Stress Ratings” may cause permanent damage to the device. This is a stress rating only and functional operation of the device at these conditions or conditions greater than those defined in the operational sections of this data sheet is not implied. Exposure to absolute maximum stress rating conditions may affect device reliability.

Table 5-1 Absolute Stress Rating

| Item | Range |
|-----------------------|----------------------|
| Required power supply | 5V ± 5% (4.75-5.25V) |

5.2 Absolute Maximum Rating

Table 5-2 lists the absolute maximum power ratings for UV110-UFD6 vDrive.

Table 5-2 Absolute Maximum Power Ratings

| Parameter | Min | Typ | Max | Unit |
|------------------------------------|------|------|------|------|
| Operating Temperature (Commercial) | 0 | +25 | +70 | °C |
| Storage Temperature (Commercial) | -25 | +25 | +85 | °C |
| Operating Temperature (Industrial) | -40 | +25 | +85 | °C |
| Storage Temperature (Industrial) | -50 | +25 | +125 | °C |
| 1.1V Regulator Power Supply | 1.04 | 1.12 | 1.20 | V |
| 1.8V Regulator Power Supply | 1.76 | 1.86 | 2.0 | V |
| 3.3V Regulator Power Supply | 3.15 | 3.3 | 3.45 | V |
| 5.0V Regulator Power Supply | 3.0 | 5.0 | 5.5 | V |
| 2.5V Regulator Power Supply | 2.35 | 2.5 | 2.7 | V |
| 1.2V Regulator Power Supply | 1.13 | 1.2 | 1.3 | V |

5.3 Power Consumption

Table 5-3 lists the power consumption for UV110-UFD6 vDrive.

Table 5-3 Power Consumption

| Mode | Capacity | 8 GB |
|------|--------------------|------|
| | Active (mA) | 85 |
| | Idle (mA) | 65 |

Notes:

- All values are typical and may vary depending on flash configurations or host system settings.
- Active power is an average power measurement performed using CrystalDiskMark with 128KB sequential read/write transfers.

6. Mechanical Specifications

Table 6-1 Dimensions

| Length | Width | Height |
|---------|---------|--------|
| 52.05mm | 17.70mm | 8.70mm |

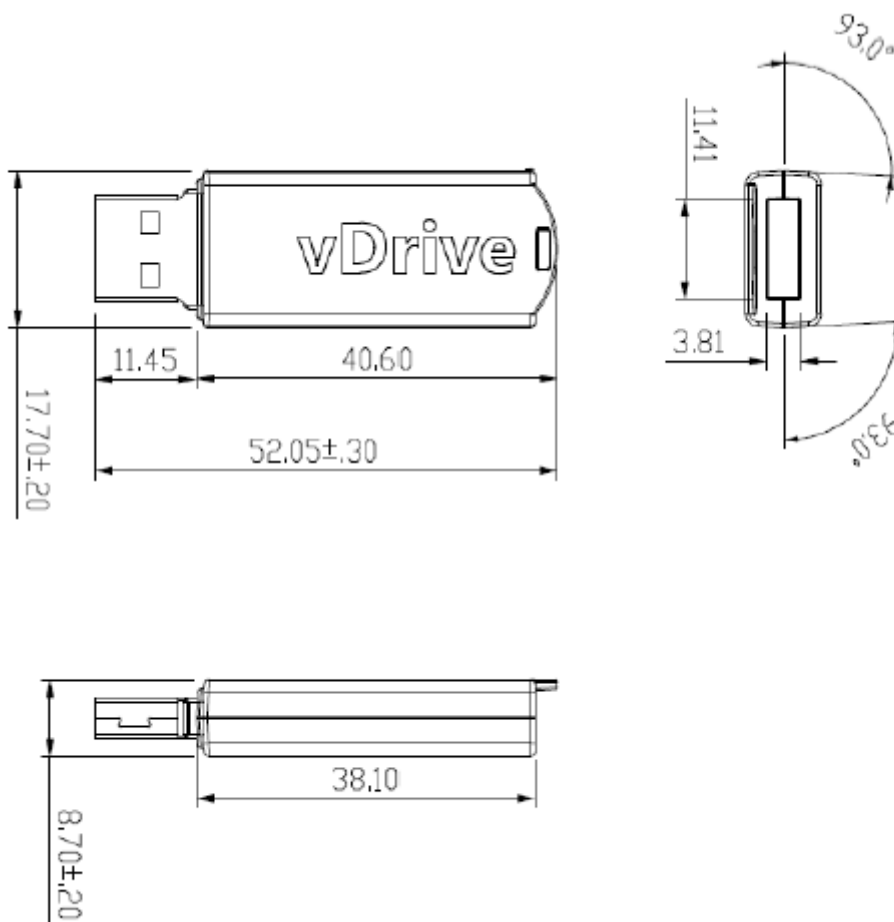

Figure 6-1 Physical Dimensions

7. Product Ordering Information

7.1 Product Code Designations

| Code | 1 | 2 | 3 | 4 | 5 | 6 | 7 | 8 | 9 | 10 | 11 | 12 | 13 | 14 | 15 | 16 |
|------|---|---|---|---|---|---|---|---|---|----|----|----|----|----|----|----|
| | A | N | 3 | . | 1 | 1 | 2 | D | G | J | . | 0 | 0 | 1 | 2 | 0 |

| | |
|--|------------------------------------|
| Code 1-3 (Product Line & Form Factor) | USB+UFD6 |
| Code 5-6 (Model/Solution) | UV110-UFD6 |
| Code 7-8 (Product Capacity) | 8GB |
| Code 9 (Flash Type & Product Temp) | 3D TLC Standard temperature |
| Code 10 (Product Spec) | UV110-UFD6 housing |
| Code 12-14 (Version Number) | Random numbers generated by system |
| Code 15-16 (Firmware Version) | UFPA325A |

7.2 Valid Combinations

The following table lists the available model of the UV110-UFD6 series which is in mass production or will be in mass production. Consult your Apacer sales representative to confirm availability of valid combinations and to determine availability of new combinations.

| Capacity | Valid Combination |
|----------|-------------------|
| 8GB | AN3.112DGJ.00120 |

Revision History

| Revision | Description | Date |
|----------|---|-----------|
| 0.1 | Preliminary release | 3/19/2021 |
| 0.2 | <ul style="list-style-type: none"> - Updated product photos on the cover page - Changed capacity from 16GB to 8GB - Updated 1. General Descriptions - Removed support of USB 3.1 - Added customized configurations to Specifications Overview and 3.1 Capacity - Updated Performance, Power Consumption, Endurance and Dimensions at Specifications Overview and 3.2 Performance, 3.6 Endurance, 5.3 Power Consumption and 6. Physical Characteristics - Updated the image at 3.7 LED Indicator Behavior | 4/23/2021 |
| 0.3 | <ul style="list-style-type: none"> - Updated Performance and Power Consumption on Specifications Overview page - Updated 3.2 Performance and 5.3 Power Consumption | 6/21/2021 |
| 1.0 | <ul style="list-style-type: none"> - Added Endurance section to Specifications Overview - Added a note to Figure 3-1 - Added 3.6 Endurance - Added 7. Product Ordering Information | 8/23/2021 |
| 1.1 | <ul style="list-style-type: none"> - Updated Endurance on Specifications Overview page and Table 3-3 - Added Table 4-1 | 9/20/2022 |

Global Presence

Taiwan (Headquarters)

Apacer Technology Inc.

1F., No.32, Zhongcheng Rd., Tucheng Dist.,
New Taipei City 236, Taiwan R.O.C.
Tel: 886-2-2267-8000
Fax: 886-2-2267-2261
amtsales@apacer.com

U.S.A.

Apacer Memory America, Inc.

46732 Lakeview Blvd., Fremont, CA 94538
Tel: 1-408-518-8699
Fax: 1-510-249-9551
sa@apacerus.com

Japan

Apacer Technology Corp.

6F, Daiyontamachi Bldg., 2-17-12, Shibaura, Minato-Ku,
Tokyo, 108-0023, Japan
Tel: 81-3-5419-2668
Fax: 81-3-5419-0018
jpservices@apacer.com

Europe

Apacer Technology B.V.

Science Park Eindhoven 5051 5692 EB Son,
The Netherlands
Tel: 31-40-267-0000
Fax: 31-40-290-0686
sales@apacer.nl

China

Apacer Electronic (Shanghai) Co., Ltd

Room D, 22/FL, No.2, Lane 600, JieyunPlaza,
Tianshan RD, Shanghai, 200051, China
Tel: 86-21-6228-9939
Fax: 86-21-6228-9936
sales@apacer.com.cn

India

Apacer Technologies Pvt Ltd,

1874, South End C Cross, 9th Block Jayanagar,
Bangalore-560069, India
Tel: 91-80-4152-9061/62
Fax: 91-80-4170-0215
sales_india@apacer.com