

**RoHS Recast Compliant**

## **USB Flash Drive**

UV110-UFD5 Product Specifications



**May 31, 2021**

**Version 1.0**



**Apacer Technology Inc.**

1F, No.32, Zhongcheng Rd., Tucheng Dist., New Taipei City, Taiwan, R.O.C

Tel: +886-2-2267-8000 Fax: +886-2-2267-2261

[www.apacer.com](http://www.apacer.com)

## Specifications Overview:

- **USB 3.1 Gen1 Super Speed compatible, and backward compatible with USB 2.0 & USB 1.1 interfaces**
  - USB 3.1 Gen1 max. transfer rate: 5 Gb/s
  - Backward compatible with 480Mb/s for USB 2.0 & 12 Mb/s for USB 1.1
- **Capacity**
  - 64, 128, 256 GB
- **Performance\***
  - Sequential read: Up to 255 MB/sec
  - Sequential write: Up to 120 MB/sec
  - Random read (4K): Up to 2,900 IOPS
  - Random write (4K): Up to 900 IOPS
- **Flash Management**
  - Built-in hardware Low Density Parity-Check (LDPC) ECC
  - Global Wear Leveling
  - Flash bad-block management
  - Flash Translation Layer: Page Mapping
  - Power Failure Management
  - S.M.A.R.T.
  - Hyper Cache Technology
  - SMART Read Refresh™
- **NAND Flash Type:** 3D TLC (BiCS3)
- **MTBF:** >3,000,000 hours
- **Endurance (in drive writes per day: DWPD)**
  - 64 GB: 4.11 DWPD
  - 128 GB: 4.11 DWPD
  - 256 GB: 4.11 DWPD
- **Temperature Range**
  - Operating:
    - Standard: 0°C to 70°C
    - Wide: -40°C to 85°C
  - Storage: -40°C to 100°C
- **Supply Voltage**
  - 5.0 V ± 5%
- **Power Consumption\***
  - Active mode: 205 mA
  - Idle mode: 75 mA
- **Supports Non-Removable Setting**
- **Supports Toggle 2.0 mode/ONFI 3.0**
- **OS Support**
  - Windows: Win7/8/10 later
  - Mac: 10.2.8/10.8 or later
  - Linux: 2.4.0/2.4.10 or later
- **Dimensions**
  - 56.05 x 18.00 x 8.50, unit: mm
- **LED Indicators for Drive Behavior**
- **RoHS Recast Compliant**
  - Complies with 2011/65/EU Standard

\*Varies from capacities. The values for performances and power consumptions presented are typical and may vary depending on flash configurations or platform settings. The term idle refers to the standby state of the device.

## Table of Contents

<b>1. General Descriptions .....</b>	<b>3</b>
<b>2. Functional Block .....</b>	<b>3</b>
<b>3. Product Specifications.....</b>	<b>4</b>
3.1 Capacity.....	4
3.2 Performance .....	4
3.3 Environmental Specifications .....	4
3.4 Mean Time Between Failures (MTBF) .....	5
3.5 Certification and Compliance.....	5
3.6 Endurance .....	5
3.7 LED Indicator Behavior.....	6
<b>4. Flash Management .....</b>	<b>7</b>
4.1 Performance-optimized USB Controller .....	7
4.2 Power Saving Implemented.....	7
4.3 Program RAM Architect.....	7
4.4 Error Correction/Detection (ECC).....	7
4.5 Global Wear Leveling .....	7
4.6 S.M.A.R.T. ....	7
4.7 Power Failure Management .....	8
4.8 Bad Block Management .....	8
4.9 Flash Translation Layer – Page Mapping.....	8
4.10 Hyper Cache Technology .....	8
4.11 SMART Read Refresh™ .....	8
<b>5. Electrical Specifications.....</b>	<b>9</b>
5.1 Absolute Stress Rating .....	9
5.2 Absolute Maximum Rating.....	9
5.3 Power Consumption .....	10
<b>6. Physical Characteristics.....</b>	<b>11</b>
<b>7. Product Ordering Information.....</b>	<b>12</b>
7.1 Product Code Designations.....	12
7.2 Valid Combinations.....	13

## 1. General Descriptions

Apacer's UV110-UFD5 utilizes 3D NAND for higher capacity up to 256GB, provides more power efficiency than 2D NAND and enhances environment and ESD protection, with the aim of replacing a conventional IDE hard disk drive.

UV110-UFD5 is a new generation USB flash drive compatible with the latest USB specification – USB 3.1 Gen1 Super Speed, with a maximum transfer rate of 5 Gb/s. The connector is backward compatible with USB 2.0 and USB 1.1 interfaces. With compliance with USB 3.1 specification, this USB drive can deliver up to 255 MB/s outstanding performance.

Reliability wise, UV110-UFD5 is implemented with LDPC (Low Density Parity Check) ECC engine to extend SSD endurance and increase data reliability. In addition, the drive comes with various implementations including powerful hardware ECC engine, wear leveling, flash block management, S.M.A.R.T., page mapping etc. This product is well suited for portable flash storage applications while operating at minimal power consumption.

## 2. Functional Block

With embedded firmware, Apacer's UV110-UFD5 contains a controller and flash media with a female connector. It interfaces with the host system allowing data to be written to and read from the flash media.

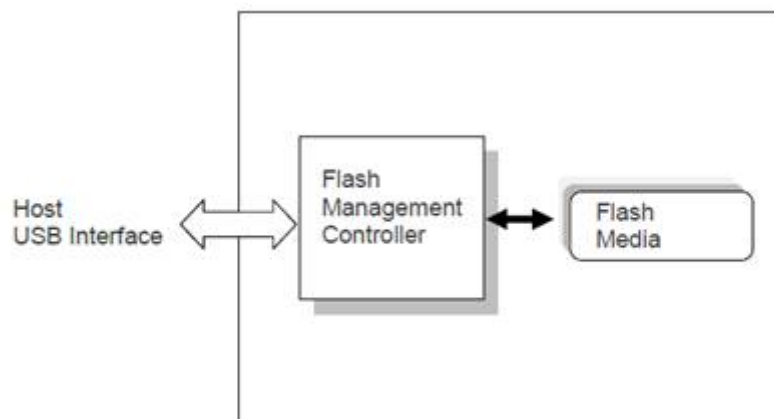

Figure 2-1 Functional Block Diagram

## 3. Product Specifications

### 3.1 Capacity

Capacity specifications of UV110-UFD5 are available as shown in Table 3-1.

**Table 3-1** Capacity Specifications

Capacity	Total bytes*	Total LBA
64 GB	62,018,519,040	121,129,920
128 GB	123,936,440,320	242,063,360
256 GB	248,074,076,160	484,519,680

\*Display of total bytes varies from file systems, which means not all of the bytes can be used for storage.

\*\*Notes: 1 GB = 1,000,000,000 bytes; 1 sector = 512 bytes.

LBA count addressed in the table above indicates total user storage capacity and will remain the same throughout the lifespan of the device. However, the total usable capacity of the SSD is most likely to be less than the total physical capacity because a small portion of the capacity is reserved for device maintenance usages.

### 3.2 Performance

Performance of UV110-UFD5 is listed below in Table 3-2.

**Table 3-2** Performance Specifications

Capacity	64 GB	128 GB	256 GB
<b>Sequential Read* (MB/s)</b>	250	255	255
<b>Sequential Write* (MB/s)</b>	110	120	115
<b>Random Read IOPS** (4K)</b>	2,800	2,900	2,900
<b>Random Write IOPS** (4K)</b>	600	700	900

Note:

Results may differ from various flash configurations or host system setting, and the above test results are based on the default file structure with FAT 32 file system.

\*Sequential performance is based on CrystalDiskMark 5.2.1 with file size 1,000MB.

\*\*Random performance measured using IOMeter with Queue Depth 32.

### 3.3 Environmental Specifications

Environmental specifications of UV110-UFD5 product are shown in Table 3-3.

**Table 3-3** Environmental Specifications

Item	Specifications
Operating temp.	0°C to 70°C (Standard); -40°C to 85°C (Wide)
Non-operating temp.	-40°C to 100°C
Operating vibration	7.69 GRMS, 20~2000 Hz/random (compliant with MIL-STD-810G)
Non-operating vibration	4.02 GRMS, 15~2000 Hz/sine (compliant with MIL-STD-810G)
Operating shock	50G, 11ms/half sine (compliant with MIL-STD-202G)
Non-operating shock	1500G, 0.5ms/half sine (compliant with MIL-STD-883K)
ESD prevention	Air discharge ±15KV; contact discharge ±8KV (IEC 61000-4-2 / EN 55035)

### 3.4 Mean Time Between Failures (MTBF)

Mean Time Between Failures (MTBF) is predicted based on reliability data for the individual components in Apacer’s USB flash drive. Serving as statistical reference, the prediction result for Apacer’s UV110-UFD5 is more than 3,000,000 hours.

Note: The MTBF is predicated and calculated based on “Telcordia Technologies Special Report, SR-332, Issue 3” method.

### 3.5 Certification and Compliance

UV110-UFD5 complies with the following standards:

- CE
- FCC
- RoHS Recast Compliant
- MIL-STD-810

### 3.6 Endurance

The endurance of a storage device is predicted by Drive Writes Per Day based on several factors related to usage, such as the amount of data written into the drive, block management conditions, and daily workload for the drive. Thus, key factors, such as Write Amplifications and the number of P/E cycles, can influence the lifespan of the drive.

**Table 3-4** Endurance Specifications

Capacity	Drive Writes Per Day
64 GB	4.11
128 GB	4.11
256 GB	4.11

Note:

- This estimation values are based on sequential write behavior. (Apacer EDTestTool, test mode – sequential data pattern -100.00% of disk space with 128K)
- Flash vendor guaranteed 3D NAND TLC P/E cycle: 3K
- WAF may vary from capacity, flash configurations and writing behavior on each platform.
- 1 Terabyte = 1,024GB
- DWPD (Drive Writes Per Day) is calculated based on the number of times that user overwrites the entire capacity of an SSD per day of its lifetime during the warranty period.

### 3.7 LED Indicator Behavior

The behavior of the UV110-UFD5 LED indicators is described in Table 3-5.

**Table 3-5** LED Behavior

Location	LED Color	Description
As indicated by the red marker below	Blue	LED blinks when the drive is being accessed such as power on, read or write. The blink frequency is 50ms switch H to L and loop.



## 4. Flash Management

### 4.1 Performance-optimized USB Controller

The heart of UV110-UFD5 is the USB controller, which translates standard USB signals into the data and controls of the flash media. This proprietary USB controller is specifically designed to attain high data throughput from host to flash.

### 4.2 Power Saving Implemented

The internal controller of the USB model is designed with power saving implementations, allowing the device to operate at low power consumption.

### 4.3 Program RAM Architect

The internal Program RAM implementation allows the host to upgrade firmware codes anytime when needed.

### 4.4 Error Correction/Detection (ECC)

UV110-UFD5 implements a hardware ECC scheme, based on the Low Density Parity Check (LDPC). LDPC is a class of linear block error correcting code which has apparent coding gain over BCH code because LDPC code includes both hard decoding and soft decoding algorithms. With the error rate decreasing, LDPC can extend SSD endurance and increase data reliability while reading raw data inside a flash chip.

### 4.5 Global Wear Leveling

Flash memory can be erased a limited number of times, This number is called the erase cycle limit, or write endurance limit, The erase cycle limit applies to each individual erase block in the flash device.

In a typical application, and especially if a file system is used, specific pages are constantly updated (e.g., the page that contains the FAT, registry, etc.). Without any special handling, these pages would wear out more rapidly than other pages, reducing the lifetime of the entire flash.

To overcome this inherent deficiency, Apacer's UV110-UFD5 uses Global Wear Leveling algorithm. This algorithm ensures that consecutive writes of a specific sector are not written physically to the same page in the flash. This spreads flash media usage evenly across all pages, thereby maximizing flash lifetime.

The Global Wear Leveling mechanism provides write/erase cycles for reliable data storage over an extended period.

### 4.6 S.M.A.R.T.

S.M.A.R.T. is an abbreviation for Self-Monitoring, Analysis and Reporting Technology, a self-monitoring system that provides indicators of drive health as well as potential disk problems. It serves as a warning for users from unscheduled downtime by monitoring and displaying critical drive information. Ideally, this should allow taking proactive actions to prevent drive failure and make use of S.M.A.R.T. information for future product development reference.

## 4.7 Power Failure Management

Power Failure Management plays a crucial role when power supply becomes unstable. Power disruption may occur when users are storing data into the SSD, leading to instability in the drive. However, with Power Failure Management, a firmware protection mechanism will be activated to scan pages and blocks once power is resumed. Valid data will be transferred to new blocks for merging and the mapping table will be rebuilt. Therefore, data reliability can be reinforced, preventing damage to data stored in the NAND Flash.

## 4.8 Bad Block Management

Current production technology is unable to guarantee total reliability of NAND flash memory array. When a flash memory device leaves factory, it comes with a minimal number of initial bad blocks during production or out-of-factory as there is no currently known technology that produce flash chips free of bad blocks. In addition, bad blocks may develop during program/erase cycles. Since bad blocks are inevitable, the solution is to keep them in control. Apacer flash devices are programmed with ECC, page mapping technique and S.M.A.R.T to reduce invalidity or error. Once bad blocks are detected, data in those blocks will be transferred to free blocks and error will be corrected by designated algorithms.

## 4.9 Flash Translation Layer – Page Mapping

Page mapping is an advanced flash management technology whose essence lies in the ability to gather data, distribute the data into flash pages automatically, and then schedule the data to be evenly written. Page-level mapping uses one page as the unit of mapping. The most important characteristic is that each logical page can be mapped to any physical page on the flash memory device. This mapping algorithm allows different sizes of data to be written to a block as if the data is written to a data pool and it does not need to take extra operations to process a write command. Thus, page mapping is adopted to increase random access speed and improve SSD lifespan, reduce block erase frequency, and achieve optimized performance and lifespan.

## 4.10 Hyper Cache Technology

Apacer proprietary Hyper Cache technology uses a portion of the available capacity as SLC (1bit-per-cell) NAND flash memory, called Hyper cache mode. When data is written to SSD, the firmware will direct the data to Hyper Cache mode, providing excellent performance to handle various scenarios in industrial use.

## 4.11 SMART Read Refresh™

Apacer's SMART Read Refresh plays a proactive role in avoiding read disturb errors from occurring to ensure health status of all blocks of NAND flash. Developed for read-intensive applications in particular, SMART Read Refresh is employed to make sure that during read operations, when the read operation threshold is reached, the data is refreshed by re-writing it to a different block for subsequent use.

## 5. Electrical Specifications

### 5.1 Absolute Stress Rating

Table 5-1 lists the absolute stress rating for UV110-UFD5.

**Caution: Absolute Maximum Stress Ratings** – Applied conditions greater than those listed under “Absolute Maximum Stress Ratings” may cause permanent damage to the device. This is a stress rating only and functional operation of the device at these conditions or conditions greater than those defined in the operational sections of this data sheet is not implied. Exposure to absolute maximum stress rating conditions may affect device reliability.

**Table 5-1** Absolute Stress Rating

Item	Range
Required power supply	5V ± 5% (4.75-5.25V)

### 5.2 Absolute Maximum Rating

Table 5-2 lists the absolute maximum power ratings for UV110-UFD5.

**Table 5-2** Absolute Maximum Power Ratings

Parameter	Min	Typ	Max	Unit
Operating Temperature (Commercial)	0	+25	+70	°C
Storage Temperature (Commercial)	-25	+25	+85	°C
Operating Temperature (Industrial)	-40	+25	+85	°C
Storage Temperature (Industrial)	-50	+25	+125	°C
1.1V Regulator Power Supply	1.04	1.12	1.20	V
1.8V Regulator Power Supply	1.76	1.86	2.0	V
3.3V Regulator Power Supply	3.15	3.3	3.45	V
5.0V Regulator Power Supply	3.0	5.0	5.5	V
2.5V Regulator Power Supply	2.35	2.5	2.7	V
1.2V Regulator Power Supply	1.13	1.2	1.3	V

### 5.3 Power Consumption

Table 5-3 lists the power consumption for UV110-UFD5.

**Table 5-3** Power Consumption

Mode \ Capacity	64 GB	128 GB	256 GB
<b>Active (mA)</b>	180	195	205
<b>Idle (mA)</b>	75	75	75

Note:

\*All values are typical and may vary depending on flash configurations or host system settings.

\*\*Active power is an average power measurement performed using CrystalDiskMark with 128KB sequential read/write transfers.

## 6. Physical Characteristics

Length	Width	Height
56.05 mm	18.00 mm	8.50 mm

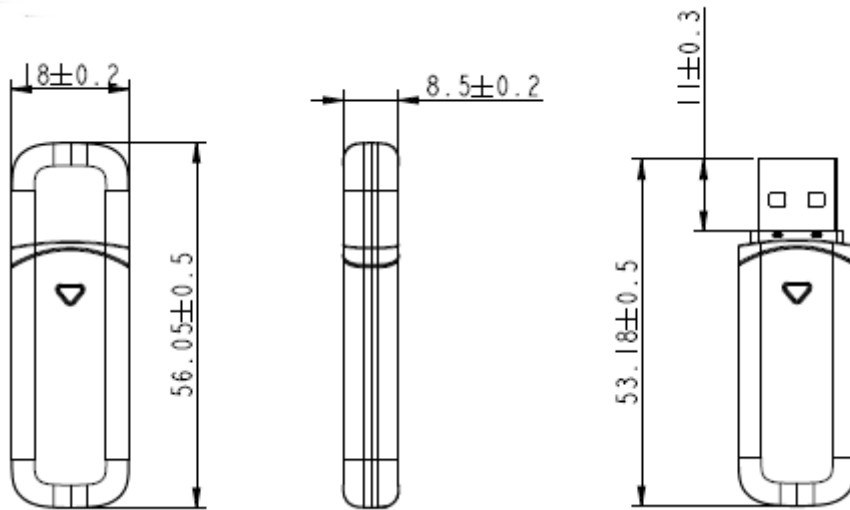

## 7. Product Ordering Information

### 7.1 Product Code Designations

Code	1	2	3	4	5	6	7	8	9	10	11	12	13	14	15	16
	A	N	2	.	1	1	2	X	X	S	.	X	X	X	1	9

<b>Code 1-3 (Product Line &amp; form factor)</b>	USB+UFD5
<b>Code 5-6 (Model/Solution)</b>	UV110-UFD5
<b>Code 7-8 (Product Capacity)</b>	2G: 64GB 2H: 128GB 2J: 256GB
<b>Code 9 (Flash Type &amp; Product Temp)</b>	G: 3D TLC Standard temperature H: 3D TLC Wide temperature
<b>Code 10 (Product Spec)</b>	S: UV110-UFD5 transparent black plastic housing
<b>Code 12-14 (Version Number)</b>	Random numbers generated by system
<b>Code 15-16 (Firmware Version)</b>	19: UFPA3ACA

## 7.2 Valid Combinations

Capacity	Standard Temperature	Wide Temperature
64GB	AN2.112GGS.00219	AN2.112GHS.00219
128GB	AN2.112HGS.00219	AN2.112HHS.00219
256GB	AN2.112JGS.00219	AN2.112JHS.00219

**Note:** Valid combinations are those products in mass production or will be in mass production. Consult your Apacer sales representative to confirm availability of valid combinations and to determine availability of new combinations.

## Revision History

Revision	Description	Date
1.0	Initial release	5/31/2021

## Global Presence

### Taiwan (Headquarters)

#### Apacer Technology Inc.

1F., No.32, Zhongcheng Rd., Tucheng Dist.,  
New Taipei City 236, Taiwan R.O.C.  
Tel: 886-2-2267-8000  
Fax: 886-2-2267-2261  
[amtsales@apacer.com](mailto:amtsales@apacer.com)

### U.S.A.

#### Apacer Memory America, Inc.

46732 Lakeview Blvd., Fremont, CA 94538  
Tel: 1-408-518-8699  
Fax: 1-510-249-9551  
[sa@apacerus.com](mailto:sa@apacerus.com)

### Japan

#### Apacer Technology Corp.

6F, Daiyontamachi Bldg., 2-17-12, Shibaura, Minato-Ku,  
Tokyo, 108-0023, Japan  
Tel: 81-3-5419-2668  
Fax: 81-3-5419-0018  
[jpservices@apacer.com](mailto:jpservices@apacer.com)

### Europe

#### Apacer Technology B.V.

Science Park Eindhoven 5051 5692 EB Son,  
The Netherlands  
Tel: 31-40-267-0000  
Fax: 31-40-290-0686  
[sales@apacer.nl](mailto:sales@apacer.nl)

### China

#### Apacer Electronic (Shanghai) Co., Ltd

Room D, 22/FL, No.2, Lane 600, JieyunPlaza,  
Tianshan RD, Shanghai, 200051, China  
Tel: 86-21-6228-9939  
Fax: 86-21-6228-9936  
[sales@apacer.com.cn](mailto:sales@apacer.com.cn)

### India

#### Apacer Technologies Pvt Ltd,

1874, South End C Cross, 9<sup>th</sup> Block Jayanagar,  
Bangalore-560069, India  
Tel: 91-80-4152-9061/62  
Fax: 91-80-4170-0215  
[sales\\_india@apacer.com](mailto:sales_india@apacer.com)