

## RoHS Compliant USB Flash Drive

### UM120-UFD5 Product Specifications



August 27, 2020

Version 1.0



**Apacer Technology Inc.**

1F, No.32, Zhongcheng Rd., Tucheng Dist., New Taipei City, Taiwan, R.O.C

Tel: +886-2-2267-8000 Fax: +886-2-2267-2261

[www.apacer.com](http://www.apacer.com)

## Specifications Overview:

- **USB3.0 Super Speed compatible, and backward compatible with USB2.0 & USB1.1 interfaces**
  - USB3.0 max. transfer rate: 5 Gb/s
  - Backward compatible with 480Mbps & 12 Mbps
- **Capacity**
  - 8, 16, 32, 64, 128 GB
- **Performance\***
  - Sequential read: up to 205 MB/s
  - Sequential write: up to 95 MB/s
- **Flash Management**
  - Flash bad-block management
  - Built-in hardware ECC
  - Power saving implemented
  - Global Wear Leveling
  - S.M.A.R.T.
  - Power Failure Management
- **USB Bus-powered Capability**
- **NAND Flash Type: MLC**
- **MTBF: >3,000,000 hours**
- **Endurance (in Terabytes Written: TBW)**
  - 8 GB: 22 TBW
  - 16 GB: 44 TBW
  - 32 GB: 88 TBW
  - 64 GB: 110 TBW
  - 128 GB: 273 TBW
- **Temperature Range**
  - Operating:
    - Standard: 0°C to 70°C
    - Wide: -40°C to 85°C
  - Storage: -40°C to 100°C
- **Power Consumption\***
  - Operating voltage: 5V
  - Active mode: 275 mA
  - Idle mode: 85 mA
- **OS Support**
  - Windows: WinXP/7 or later
  - Mac: 10.2.8 or later
  - Linux: 2.4.10 or later
- **Dimensions: 56.05 x 18.00 x 8.50, unit: mm**
- **LED Indicators for Drive Behavior**
- **RoHS Compliant**

\*Varies from capacities. The values for performances and power consumptions presented are typical and may vary depending on flash configurations or platform settings.

## Table of Contents

<b>1. General Descriptions .....</b>	<b>3</b>
<b>2. Product Specifications.....</b>	<b>4</b>
2.1 Capacity.....	4
2.2 Performance .....	4
2.3 Environmental Specifications .....	4
2.4 Mean Time Between Failures (MTBF) .....	5
2.5 Certification and Compliance.....	5
2.6 Endurance .....	5
2.7 LED Indicator Behavior.....	5
<b>3. Flash Management .....</b>	<b>6</b>
3.1 Performance-optimized USB Controller .....	6
3.2 Power Saving Implemented.....	6
3.3 Program RAM Architect.....	6
3.4 Error Correction Code (ECC) .....	6
3.5 Flash Block Management .....	6
3.6 Power Failure Management .....	6
3.7 Global Wear Leveling .....	7
3.8 S.M.A.R.T. ....	7
<b>4. Electrical Specifications.....</b>	<b>8</b>
4.1 Absolute Stress Rating .....	8
4.2 Power Consumption .....	8
<b>5. Physical Dimensions .....</b>	<b>9</b>
<b>6. Product Ordering Information.....</b>	<b>10</b>
6.1 Product Code Designations.....	10
6.2 Valid Combinations.....	11

## 1. General Descriptions

Apacer USB3.0 Handy Flash Drive UM120-UFD5 is a ultra high-performance flash disk drive designed offering portable storage solutions or external memory expansion. This new generation USB flash drive is compatible with the latest USB specification – USB3.0 Super Speed, with a maximum transfer rate of 5 Gb/s. The connector is backward employable with USB2.0 and USB1.1 interfaces as well. With compliance with USB3.0 specification, this USB drive can deliver up to 205 MB/s outstanding performance. Reliability wise, the USB comes with various implementations including powerful hardware ECC engine, power saving modes, wear leveling and flash block management. This product is well suited for portable flash storage applications while operating at minimal power consumption.

## 2. Product Specifications

### 2.1 Capacity

Capacity specifications of UM120-UFD5 are available as shown in Table 2-1. It lists the specific capacity and the default numbers of heads, sectors and cylinders for each product line.

**Table 2-1** Capacity Specifications

Capacity	Total bytes*	Total LBA
8 GB	8,011,120,640	15,646,720
16 GB	16,039,018,496	31,326,208
32 GB	32,044,482,560	62,586,880
64 GB	64,055,410,688	125,108,224
128 GB	128,110,821,376	250,216,448

\*Display of total bytes varies from file systems, which means not all of the bytes can be used for storage.

\*\*Notes: 1 GB = 1,000,000,000 bytes; 1 sector = 512 bytes.

LBA count addressed in the table above indicates total user storage capacity and will remain the same throughout the lifespan of the device. However, the total usable capacity of the SSD is most likely to be less than the total physical capacity because a small portion of the capacity is reserved for device maintenance usages.

### 2.2 Performance

Performance of UM120-UFD5 is listed below in Table 2-2.

**Table 2-2** Performance Specifications

Capacity \ Performance	8 GB**		16 GB	32 GB	64 GB	128 GB***	
	Sequential Read* (MB/s)	Sequential Write* (MB/s)	Sequential Read* (MB/s)	Sequential Write* (MB/s)	Sequential Read* (MB/s)	Sequential Write* (MB/s)	Sequential Read* (MB/s)
Sequential Read* (MB/s)	205	95	190	190	185	190	195
Sequential Write* (MB/s)	20	29	55	45	95	95	80

Note:

Results may differ from various flash configurations or host system setting.

\*Sequential performance is based on CrystalDiskMark 5.2.1 with file size 1,000MB.

\*\*Values on the left are measured on 32Gb x2 while those on the right are measured on 64Gb x1.

\*\*\*Values on the left are measured on 512Gb x2 while those on the right are measured on 1Tb x1.

### 2.3 Environmental Specifications

Environmental specifications of UM120-UFD5 product are shown in Table 2-3.

**Table 2-3** Environmental Specifications

Item	Specifications
Operating temp.	0°C to 70°C (Standard); -40°C to 85°C (Wide)
Non-operating temp.	-40°C to 100°C
Operating vibration	7.69 GRMS, 20~2000 Hz/random (compliant with MIL-STD-810G)
Non-operating vibration	4.02 GRMS, 15~2000 Hz/sine (compliant with MIL-STD-810G)
Operating shock	50G, 11ms/half-sine (compliant with MIL-STD-202G)
Non-operating shock	1,500G, 0.5ms/half-sine (compliant with MIL-STD-883K)

## 2.4 Mean Time Between Failures (MTBF)

Mean Time Between Failures (MTBF) is predicted based on reliability data for the individual components in UM120-UFD5. The prediction result for UM120-UFD5 is more than 3,000,000 hours.

Note: The MTBF is predicated and calculated based on “Telcordia Technologies Special Report, SR-332, Issue 3” method.

## 2.5 Certification and Compliance

UM120-UFD5 complies with the following standards:

- CE (Criteria B)

## 2.6 Endurance

The endurance of a storage device is predicted by TeraBytes Written based on several factors related to usage, such as the amount of data written into the drive, block management conditions, and daily workload for the drive. Thus, key factors, such as Write Amplifications and the number of P/E cycles, can influence the lifespan of the drive.

**Table 2-4** Endurance Specifications

Capacity	TeraBytes Written
8 GB	22
16 GB	44
32 GB	88
64 GB	110
128 GB	273

Note:

- The estimated values are based on sequential write behavior. (Apacer EDTest Tool, test mode – sequential data pattern – 100.00% of disk space with 128K)
- Flash vendor guaranteed MLC P/E cycle: 3K.
- WAF may vary from capacity, flash configurations and writing behavior on each platform.
- 1 Terabyte = 1,024 GB.

## 2.7 LED Indicator Behavior

The behavior of the UM120-UFD5 LED indicators is described in Table 2-5.

**Table 2-5** LED Behavior

Location	LED Color	Description
As indicated by the red marker below	Blue	LED blinks when the drive is being accessed such as power on, read or write. The blink frequency is 50ms switch H to L and loop.



## 3. Flash Management

### 3.1 Performance-optimized USB Controller

The heart of UM120-UFD5 is the USB controller, which translates standard USB signals into the data and controls of the flash media. This proprietary USB controller is specifically designed to attain high data throughput from host to flash.

### 3.2 Power Saving Implemented

The internal controller of the USB model is designed with power saving implementations, allowing the device to operate at low power consumption.

### 3.3 Program RAM Architect

The internal Program RAM implementation allows the host to upgrade firmware codes anytime when needed.

### 3.4 Error Correction Code (ECC)

Flash memory cells can deteriorate with use, which might lead to random bit errors in the stored data. Thus, this USB applies the BCH ECC Algorithm, which can detect and correct errors occurring during Read process, ensure data to be read correctly, as well as protect data from corruption. This device can correct up to 39bit/1K data.

### 3.5 Flash Block Management

Current production technology is unable to guarantee total reliability of NAND flash memory array. When a flash memory device leaves factory, it comes with a minimal number of initial bad blocks during production or out-of-factory as there is no currently known technology that produce flash chips free of bad blocks. In addition, bad blocks may develop during program/erase cycles. Since bad blocks are inevitable, the solution is to keep them in control. Apacer flash devices are programmed with ECC and block mapping technique to reduce invalidity or error. Once bad blocks are detected, data in those blocks will be transferred to free blocks and error will be corrected by designated algorithms.

### 3.6 Power Failure Management

Power Failure Management plays a crucial role when power supply becomes unstable. Power disruption may occur when users are storing data into the SSD, leading to instability in the drive. However, with Power Failure Management, a firmware protection mechanism will be activated to scan pages and blocks once power is resumed. Valid data will be transferred to new blocks for merging and the mapping table will be rebuilt. Therefore, data reliability can be reinforced, preventing damage to data stored in the NAND Flash.

## 3.7 Global Wear Leveling

Flash memory can be erased a limited number of times, This number is called the erase cycle limit, or write endurance limit, The erase cycle limit applies to each individual erase block in the flash device.

In a typical application, and especially if a file system is used, specific pages are constantly updated (e.g., the page that contains the FAT, registry, etc.). Without any special handling, these pages would wear out more rapidly than other pages, reducing the lifetime of the entire flash.

To overcome this inherent deficiency, Apacer's UM120-UFD5 uses Global Wear Leveling algorithm. This algorithm ensures that consecutive writes of a specific sector are not written physically to the same page in the flash. This spreads flash media usage evenly across all pages, thereby maximizing flash lifetime.

The Global Wear Leveling mechanism provides write/erase cycles for reliable data storage over an extended period.

## 3.8 S.M.A.R.T.

S.M.A.R.T. is an abbreviation for Self-Monitoring, Analysis and Reporting Technology, a self-monitoring system that provides indicators of drive health as well as potential disk problems. It serves as a warning for users from unscheduled downtime by monitoring and displaying critical drive information. Ideally, this should allow taking proactive actions to prevent drive failure and make use of S.M.A.R.T. information for future product development reference.

## 4. Electrical Specifications

### 4.1 Absolute Stress Rating

Table 4-1 lists the absolute stress rating for UM120-UFD5.

**Caution: Absolute Maximum Stress Ratings** – Applied conditions greater than those listed under “Absolute Maximum Stress Ratings” may cause permanent damage to the device. This is a stress rating only and functional operation of the device at these conditions or conditions greater than those defined in the operational sections of this data sheet is not implied. Exposure to absolute maximum stress rating conditions may affect device reliability.

**Table 4-1** Absolute Stress Rating

Item	Range
Required power supply	4.5-5.5V
Operating temperature	0°C to 70°C (Standard); -40°C to 85°C (Wide)
Storage temperature	0°C to 100°C

### 4.2 Power Consumption

Table 4-2 lists the power consumption for UM120-UFD5.

**Table 4-2** Power Consumption

Mode \ Capacity	8 GB <sup>***</sup>		16 GB	32 GB	64 GB	128 GB <sup>****</sup>	
	165	150	270	265	275	265	175
Active (mA)	165	150	270	265	275	265	175
Idle (mA)	75	50	85	80	80	55	35

Note:

\*All values are typical and may vary depending on flash configurations or host system settings.

\*\*Active power is an average power measurement performed using CrystalDiskMark with 128KB sequential read/write transfers.

\*\*\*Values on the left are measured on 32Gb x2 while those on the right are measured on 64Gb x1.

\*\*\*\*Values on the left are measured on 512Gb x2 while those on the right are measured on 1Tb x1.

## 5. Physical Dimensions

Length	Width	Height (Max)
56.05 mm	18.00 mm	8.50 mm

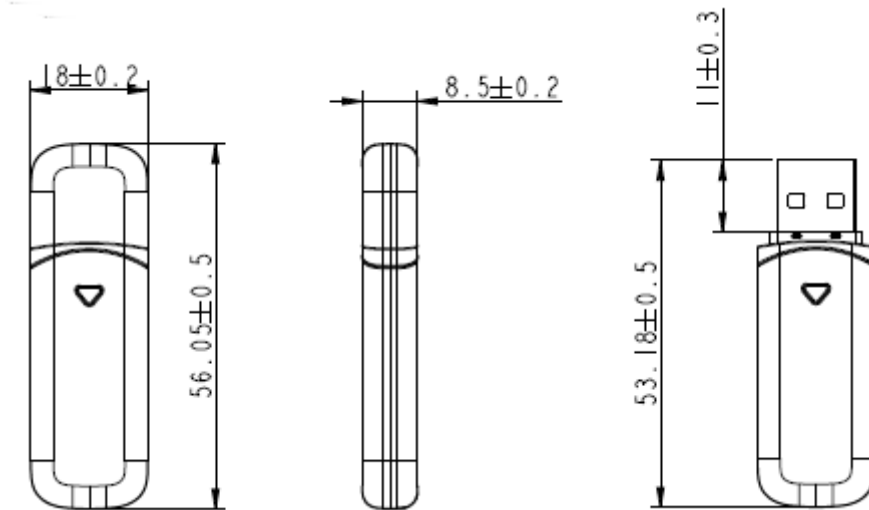

Unit: mm

## 6. Product Ordering Information

### 6.1 Product Code Designations

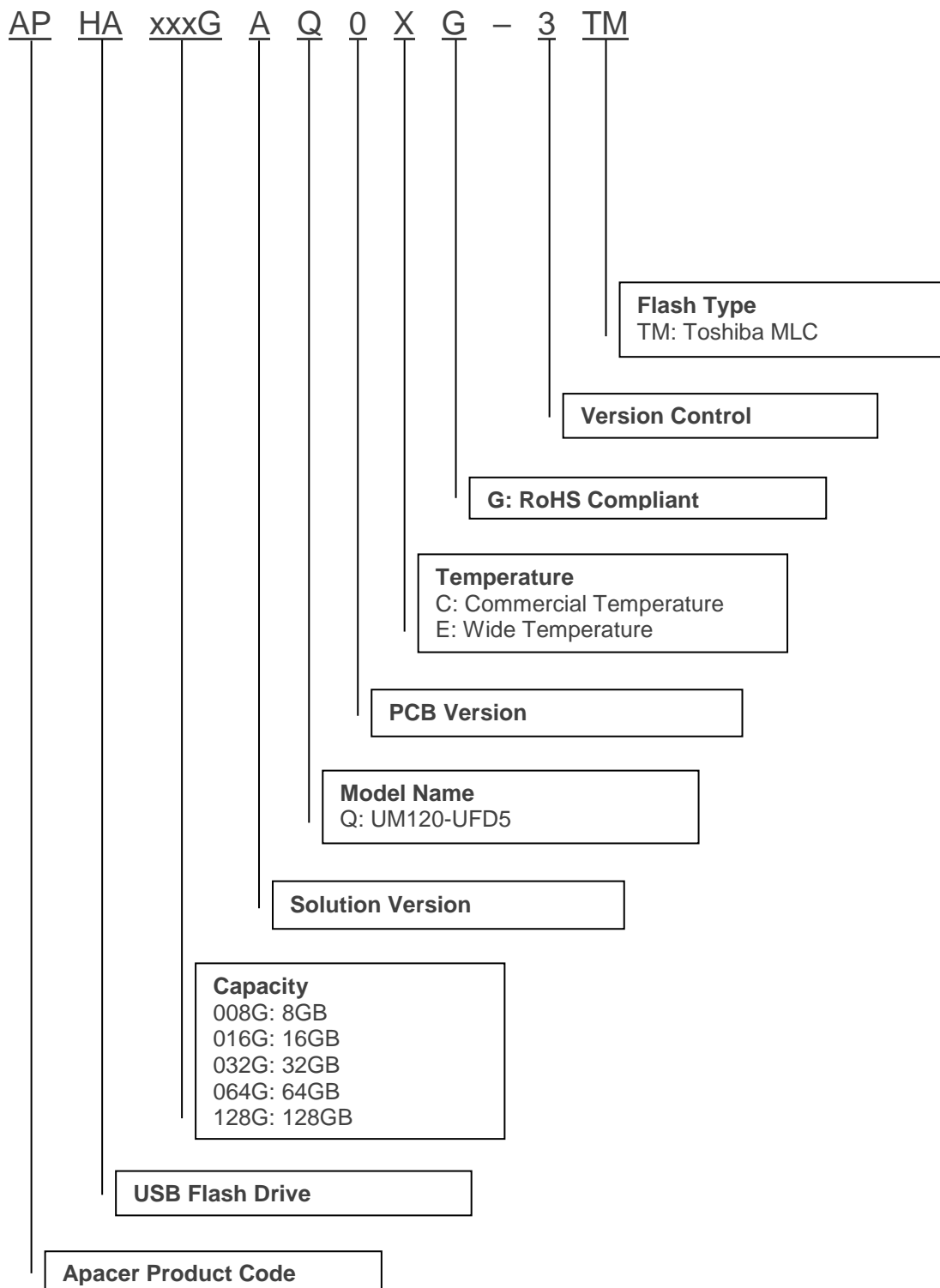

## 6.2 Valid Combinations

Capacity	Standard Temperature	Wide Temperature
8GB	APHA008GAQ0CG-3TM*	APHA008GAQ0EG-3TM*
16GB	APHA016GAQ0CG-3TM	APHA016GAQ0EG-3TM
32GB	APHA032GAQ0CG-3TM	APHA032GAQ0EG-3TM
64GB	APHA064GAQ0CG-3TM	APHA064GAQ0EG-3TM
128GB	APHA128GAQ0CG-3TM	APHA128GAQ0EG-3TM

**Note:** Valid combinations are those products in mass production or will be in mass production. Consult your Apacer sales representative to confirm availability of valid combinations and to determine availability of new combinations.

\*The part number with one asterisk represents the SSD manufactured based on 64Gb x1.

## Revision History

Revision	Description	Date
1.0	Initial release	8/27/2020

## Global Presence

### Taiwan (Headquarters)

#### Apacer Technology Inc.

1F., No.32, Zhongcheng Rd., Tucheng Dist.,  
New Taipei City 236, Taiwan R.O.C.  
Tel: 886-2-2267-8000  
Fax: 886-2-2267-2261  
[amtsales@apacer.com](mailto:amtsales@apacer.com)

### U.S.A.

#### Apacer Memory America, Inc.

46732 Lakeview Blvd., Fremont, CA 94538  
Tel: 1-408-518-8699  
Fax: 1-510-249-9551  
[sa@apacerus.com](mailto:sa@apacerus.com)

### Japan

#### Apacer Technology Corp.

6F, Daiyontamachi Bldg., 2-17-12, Shibaura, Minato-Ku,  
Tokyo, 108-0023, Japan  
Tel: 81-3-5419-2668  
Fax: 81-3-5419-0018  
[jpservices@apacer.com](mailto:jpservices@apacer.com)

### Europe

#### Apacer Technology B.V.

Science Park Eindhoven 5051 5692 EB Son,  
The Netherlands  
Tel: 31-40-267-0000  
Fax: 31-40-290-0686  
[sales@apacer.nl](mailto:sales@apacer.nl)

### China

#### Apacer Electronic (Shanghai) Co., Ltd

Room D, 22/FL, No.2, Lane 600, JieyunPlaza,  
Tianshan RD, Shanghai, 200051, China  
Tel: 86-21-6228-9939  
Fax: 86-21-6228-9936  
[sales@apacer.com.cn](mailto:sales@apacer.com.cn)

### India

#### Apacer Technologies Pvt Ltd,

1874, South End C Cross, 9<sup>th</sup> Block Jayanagar,  
Bangalore-560069, India  
Tel: 91-80-4152-9061/62  
Fax: 91-80-4170-0215  
[sales\\_india@apacer.com](mailto:sales_india@apacer.com)