

RoHS Recast Compliant

USB Flash Drive

UH110-UFD1 Product Specifications



September 29, 2021

Version 1.4



Apacer Technology Inc.

1F, No.32, Zhongcheng Rd., Tucheng Dist., New Taipei City, Taiwan, R.O.C

Tel: +886-2-2267-8000 Fax: +886-2-2267-2261

www.apacer.com

Specifications Overview:

- **USB 3.1 Gen1 Super Speed compatible, and backward compatible with USB 2.0 & USB 1.1 interfaces**
 - USB 3.1 Gen1 max. transfer rate: 5 Gb/s
 - Backward compatible with 480Mb/s for USB 2.0 & 12 Mb/s for USB 1.1
- **Capacity**
 - 16, 32, 64 GB
- **Performance***
 - Sequential read: Up to 265 MB/sec
 - Sequential write: Up to 125 MB/sec
 - Random read (4K): Up to 3,000 IOPS
 - Random write (4K): Up to 1,100 IOPS
- **Flash Management**
 - Built-in hardware Low Density Parity-Check (LDPC) ECC
 - Global Wear Leveling
 - Flash bad-block management
 - Flash Translation Layer: Page Mapping
 - Power Failure Management
 - S.M.A.R.T.
 - SMART Read Refresh™
 - SLC-liteX
- **NAND Flash Type:** 3D TLC (BiCS3)
- **MTBF:** >3,000,000 hours
- **Endurance (in Terabytes Written: TBW)**
 - 16 GB: 624 TBW
 - 32 GB: 1,249 TBW
 - 64 GB: 2,499 TBW
- **Temperature Range**
 - Operating:
 - Standard: 0°C to 70°C
 - Wide: -40°C to 85°C
 - Storage: -55°C to 100°C
- **Supply Voltage**
 - 5.0 V ± 5%
- **Power Consumption***
 - Active mode: 190 mA
 - Idle mode: 80 mA
- **Supports Non-Removable Setting**
- **Supports Toggle 2.0 mode/ONFI 3.0**
- **OS Support**
 - Windows: Win7/8/10 later
 - Mac: 10.2.8/10.8 or later
 - Linux: 2.4.0/2.4.10 or later
- **Dimensions**
 - 46.85 x 17.2 x 7.7, unit: mm
- **LED Indicators for Drive Behavior**
- **RoHS Recast Compliant**
 - Complies with 2011/65/EU Standard)

*Varies from capacities. The values for performances and power consumptions presented are typical and may vary depending on flash configurations or platform settings. The term idle refers to the standby state of the device.

Table of Contents

| | |
|---|-----------|
| 1. General Descriptions | 3 |
| 2. Functional Block | 3 |
| 3. Product Specifications..... | 4 |
| 3.1 Capacity..... | 4 |
| 3.2 Performance | 4 |
| 3.3 Environmental Specifications | 4 |
| 3.4 Mean Time Between Failures (MTBF) | 5 |
| 3.5 Certification and Compliance..... | 5 |
| 3.6 Endurance | 5 |
| 3.7 LED Indicator Behavior..... | 5 |
| 4. Flash Management | 6 |
| 4.1 Performance-optimized USB Controller | 6 |
| 4.2 Power Saving Implemented..... | 6 |
| 4.3 Program RAM Architect..... | 6 |
| 4.4 Error Correction/Detection (ECC)..... | 6 |
| 4.5 Global Wear Leveling | 6 |
| 4.6 S.M.A.R.T. | 6 |
| 4.7 Power Failure Management | 7 |
| 4.8 Bad Block Management | 7 |
| 4.9 Flash Translation Layer – Page Mapping..... | 7 |
| 4.10 SLC-liteX..... | 7 |
| 4.11 SMART Read Refresh™ | 7 |
| 5. Electrical Specifications..... | 8 |
| 5.1 Absolute Stress Rating | 8 |
| 5.2 Absolute Maximum Rating..... | 8 |
| 5.3 Power Consumption | 9 |
| 6. Physical Characteristics..... | 10 |
| 7. Product Ordering Information..... | 11 |
| 7.1 Product Code Designations..... | 11 |
| 7.2 Valid Combinations..... | 12 |

1. General Descriptions

Apacer's UH110-UFD1 utilizes 3D NAND for higher capacity up to 64GB and provides more power efficiency than 2D NAND, with the aim of replacing a conventional IDE hard disk drive. With exquisite size and robust metal housing, UH110-UFD1 prevents mechanical interference and enhances environment and ESD protection.

UH110-UFD1 is a new generation USB flash drive compatible with the latest USB specification – USB 3.1 Gen1 Super Speed, with a maximum transfer rate of 5 Gb/s. The connector is backward compatible with USB 2.0 and USB 1.1 interfaces. With compliance with USB 3.1 specification, this USB drive can deliver up to 265 MB/s outstanding performance.

Reliability wise, UH110-UFD1 is implemented with LDPC (Low Density Parity Check) ECC engine to extend SSD endurance and increase data reliability while reading raw data inside a flash chip. In addition, the drive comes with various implementations including powerful hardware ECC engine, wear leveling, flash block management, S.M.A.R.T., page mapping etc. This product is well suited for portable flash storage applications while operating at minimal power consumption.

2. Functional Block

With embedded firmware, Apacer's UH110-UFD1 contains a controller and flash media with a female connector. It interfaces with the host system allowing data to be written to and read from the flash media.

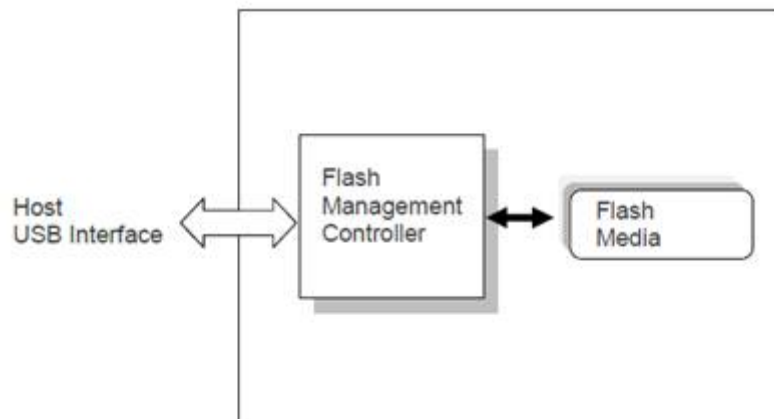

Figure 2-1 Functional Block Diagram

3. Product Specifications

3.1 Capacity

Capacity specifications of UH110-UFD1 are available as shown in Table 3-1.

Table 3-1 Capacity Specifications

| Capacity | Total bytes* | Total LBA |
|----------|----------------|-------------|
| 16 GB | 15,522,103,296 | 30,316,608 |
| 32 GB | 31,041,060,864 | 60,627,072 |
| 64 GB | 61,978,312,704 | 121,051,392 |

*Display of total bytes varies from file systems, which means not all of the bytes can be used for storage.

**Notes: 1 GB = 1,000,000,000 bytes; 1 sector = 512 bytes.

LBA count addressed in the table above indicates total user storage capacity and will remain the same throughout the lifespan of the device. However, the total usable capacity of the SSD is most likely to be less than the total physical capacity because a small portion of the capacity is reserved for device maintenance usages.

3.2 Performance

Performance of UH110-UFD1 is listed below in Table 3-2.

Table 3-2 Performance Specifications

| Capacity | 16 GB | 32 GB | 64 GB |
|---------------------------------|-------|-------|-------|
| Performance | | | |
| Sequential Read* (MB/s) | 265 | 250 | 265 |
| Sequential Write* (MB/s) | 115 | 120 | 125 |
| Random Read IOPS** (4K) | 3,000 | 3,000 | 2,900 |
| Random Write IOPS** (4K) | 1,000 | 1,100 | 1,000 |

Note:

Results may differ from various flash configurations or host system setting, and the above test results are based on the default file structure with FAT 32 file system.

*Sequential performance is based on CrystalDiskMark 5.2.1 with file size 1,000MB.

**Random performance measured using IOMeter with Queue Depth 32.

3.3 Environmental Specifications

Environmental specifications of UH110-UFD1 product are shown in Table 3-3.

Table 3-3 Environmental Specifications

| Item | Specifications |
|-------------------------|--|
| Operating temp. | 0°C to 70°C (Standard); -40°C to 85°C (Wide) |
| Non-operating temp. | -55°C to 100°C |
| Operating vibration | 7.69 GRMS, 20~2000 Hz/random (compliant with MIL-STD-810G) |
| Non-operating vibration | 4.02 GRMS, 15~2000 Hz/sine (compliant with MIL-STD-810G) |
| Operating shock | 50G, 11ms/half sine (compliant with MIL-STD-202G) |
| Non-operating shock | 1500G, 0.5ms/half sine (compliant with MIL-STD-883K) |

3.4 Mean Time Between Failures (MTBF)

Mean Time Between Failures (MTBF) is predicted based on reliability data for the individual components in Apacer’s USB flash drive. Serving as statistical reference, the prediction result for Apacer’s UH110-UFD1 is more than 3,000,000 hours.

Note: The MTBF is predicated and calculated based on “Telcordia Technologies Special Report, SR-332, Issue 3” method.

3.5 Certification and Compliance

UH110-UFD1 complies with the following standards:

- CE
- FCC
- RoHS Recast Compliant
- MIL-STD-810

3.6 Endurance

The endurance of a storage device is predicted by TeraBytes Written based on several factors related to usage, such as the amount of data written into the drive, block management conditions, and daily workload for the drive. Thus, key factors, such as Write Amplifications and the number of P/E cycles, can influence the lifespan of the drive.

Table 3-4 Endurance Specifications

| Capacity | TeraBytes Written |
|----------|-------------------|
| 16 GB | 624 |
| 32 GB | 1,249 |
| 64 GB | 2,499 |

Note:

- This estimation values are based on sequential write behavior. (Apacer EDTestTool, test mode –sequential data pattern -100.00% of disk space with 128K)
- Flash vendor guaranteed SLC-liteX P/E cycle: 30K
- WAF may vary from capacity, flash configurations and writing behavior on each platform.
- 1 Terabyte = 1,024GB

3.7 LED Indicator Behavior

The behavior of the UH110-UFD1 LED indicators is described in Table 3-5.

Table 3-5 LED Behavior

| Location | LED Color | Description |
|--------------------------------------|-----------|---|
| As indicated by the red marker below | Blue | LED blinks when the drive is being accessed such as power on, read or write. The blink frequency is 50ms switch H to L and loop |



4. Flash Management

4.1 Performance-optimized USB Controller

The heart of UH110-UFD1 is the USB controller, which translates standard USB signals into the data and controls of the flash media. This proprietary USB controller is specifically designed to attain high data throughput from host to flash.

4.2 Power Saving Implemented

The internal controller of the USB model is designed with power saving implementations, allowing the device to operate at low power consumption.

4.3 Program RAM Architect

The internal Program RAM implementation allows the host to upgrade firmware codes anytime when needed.

4.4 Error Correction/Detection (ECC)

UH110-UFD1 implements a hardware ECC scheme, based on the Low Density Parity Check (LDPC). LDPC is a class of linear block error correcting code which has apparent coding gain over BCH code because LDPC code includes both hard decoding and soft decoding algorithms. With the error rate decreasing, LDPC can extend SSD endurance and increase data reliability while reading raw data inside a flash chip.

4.5 Global Wear Leveling

Flash memory can be erased a limited number of times, This number is called the erase cycle limit, or write endurance limit, The erase cycle limit applies to each individual erase block in the flash device.

In a typical application, and especially if a file system is used, specific pages are constantly updated (e.g., the page that contains the FAT, registry, etc.). Without any special handling, these pages would wear out more rapidly than other pages, reducing the lifetime of the entire flash.

To overcome this inherent deficiency, Apacer's UH110-UFD1 uses Global Wear Leveling algorithm. This algorithm ensures that consecutive writes of a specific sector are not written physically to the same page in the flash. This spreads flash media usage evenly across all pages, thereby maximizing flash lifetime.

The Global Wear Leveling mechanism provides write/erase cycles for reliable data storage over an extended period.

4.6 S.M.A.R.T.

S.M.A.R.T. is an abbreviation for Self-Monitoring, Analysis and Reporting Technology, a self-monitoring system that provides indicators of drive health as well as potential disk problems. It serves as a warning for users from unscheduled downtime by monitoring and displaying critical drive information. Ideally, this should allow taking proactive actions to prevent drive failure and make use of S.M.A.R.T. information for future product development reference.

4.7 Power Failure Management

Power Failure Management plays a crucial role when power supply becomes unstable. Power disruption may occur when users are storing data into the SSD, leading to instability in the drive. However, with Power Failure Management, a firmware protection mechanism will be activated to scan pages and blocks once power is resumed. Valid data will be transferred to new blocks for merging and the mapping table will be rebuilt. Therefore, data reliability can be reinforced, preventing damage to data stored in the NAND Flash.

4.8 Bad Block Management

Current production technology is unable to guarantee total reliability of NAND flash memory array. When a flash memory device leaves factory, it comes with a minimal number of initial bad blocks during production or out-of-factory as there is no currently known technology that produce flash chips free of bad blocks. In addition, bad blocks may develop during program/erase cycles. Since bad blocks are inevitable, the solution is to keep them in control. Apacer flash devices are programmed with ECC, page mapping technique and S.M.A.R.T to reduce invalidity or error. Once bad blocks are detected, data in those blocks will be transferred to free blocks and error will be corrected by designated algorithms.

4.9 Flash Translation Layer – Page Mapping

Page mapping is an advanced flash management technology whose essence lies in the ability to gather data, distribute the data into flash pages automatically, and then schedule the data to be evenly written. Page-level mapping uses one page as the unit of mapping. The most important characteristic is that each logical page can be mapped to any physical page on the flash memory device. This mapping algorithm allows different sizes of data to be written to a block as if the data is written to a data pool and it does not need to take extra operations to process a write command. Thus, page mapping is adopted to increase random access speed and improve SSD lifespan, reduce block erase frequency, and achieve optimized performance and lifespan.

4.10 SLC-liteX

SLC-liteX is based on 3D NAND technology. The firmware is carefully tweaked by our engineering team so as to offer the greatest number of P/E cycles in this format – 30,000, which is 10 times more than MLC or industrial 3D TLC. The longest lifespans are therefore available at reasonable cost.

4.11 SMART Read Refresh™

Apacer's SMART Read Refresh plays a proactive role in avoiding read disturb errors from occurring to ensure health status of all blocks of NAND flash. Developed for read-intensive applications in particular, SMART Read Refresh is employed to make sure that during read operations, when the read operation threshold is reached, the data is refreshed by re-writing it to a different block for subsequent use.

5. Electrical Specifications

5.1 Absolute Stress Rating

Table 5-1 lists the absolute stress rating for UH110-UFD1.

Caution: Absolute Maximum Stress Ratings – Applied conditions greater than those listed under “Absolute Maximum Stress Ratings” may cause permanent damage to the device. This is a stress rating only and functional operation of the device at these conditions or conditions greater than those defined in the operational sections of this data sheet is not implied. Exposure to absolute maximum stress rating conditions may affect device reliability.

Table 5-1 Absolute Stress Rating

| Item | Range |
|-----------------------|--------------------------|
| Required power supply | 5V \pm 5% (4.75-5.25V) |

5.2 Absolute Maximum Rating

Table 5-2 lists the absolute maximum power ratings for UH110-UFD1.

Table 5-2 Absolute Maximum Power Ratings

| Parameter | Min | Typ | MAX | Unit |
|------------------------------------|------|------|------|------|
| Operating Temperature (Commercial) | 0 | +25 | +70 | °C |
| Storage Temperature (Commercial) | -25 | +25 | +85 | °C |
| Operating Temperature (Industrial) | -40 | +25 | +85 | °C |
| Storage Temperature (Industrial) | -50 | +25 | +125 | °C |
| 1.1V regulator power supply | 1.04 | 1.12 | 1.20 | V |
| 1.8V regulator power supply | 1.76 | 1.86 | 2.0 | V |
| 3.3V Regulator Power Supply | 3.15 | 3.3 | 3.45 | V |
| 5.0V Regulator Power Supply | 3.0 | 5.0 | 5.5 | V |
| 2.5V regulator power supply | 2.35 | 2.5 | 2.7 | V |
| 1.2V regulator power supply | 1.13 | 1.2 | 1.3 | V |

5.3 Power Consumption

Table 5-3 lists the power consumption for UH110-UFD1.

Table 5-3 Power Consumption

| Mode \ Capacity | 16GB | 32 GB | 64 GB |
|--------------------|------|-------|-------|
| Active (mA) | 185 | 180 | 190 |
| Idle (mA) | 80 | 80 | 80 |

Note:

*All values are typical and may vary depending on flash configurations or host system settings.

**Active power is an average power measurement performed using CrystalDiskMark with 128KB sequential read/write transfers.

6. Physical Characteristics

| Length | Width | Height |
|---------|--------|--------|
| 46.85mm | 17.2mm | 7.7mm |

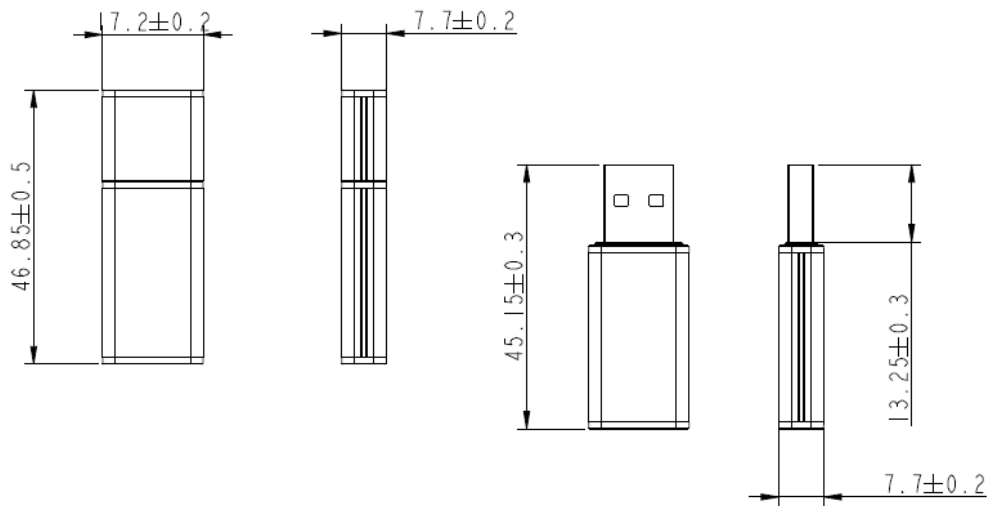

7. Product Ordering Information

7.1 Product Code Designations

| Code | 1 | 2 | 3 | 4 | 5 | 6 | 7 | 8 | 9 | 10 | 11 | 12 | 13 | 14 | 15 | 16 |
|------|---|---|---|---|---|---|---|---|---|----|----|----|----|----|----|----|
| | A | N | 2 | . | 1 | 1 | 8 | X | X | G | . | X | X | X | 1 | 4 |

| | |
|--|--|
| Code 1-3 (Product Line & Form Factor) | USB+UFD1 |
| Code 5-6 (Model/Solution) | UH110-UFD1 |
| Code 7-8 (Product Capacity) | 8G: 16GB (SLC-liteX) 8H: 32GB (SLC-liteX) 8J: 64GB (SLC-liteX) |
| Code 9 (Flash Type & Product Temp) | L: 3D SLC-liteX Standard temperature M: 3D SLC-liteX Wide temperature |
| Code 10 (Product Spec) | UH110-UFD1 silver-gray housing |
| Code 12-14 (Version Number) | Random numbers generated by system |
| Code 15-16 (Firmware Version) | UFPA4A9A |

7.2 Valid Combinations

| Capacity | Standard Temperature | Wide Temperature |
|----------|----------------------|------------------|
| 16GB | AN2.118GLG.00114 | AN2.118GMG.00114 |
| 32GB | AN2.118HLG.00114 | AN2.118HMG.00114 |
| 64GB | AN2.118JLG.00114 | AN2.118JMG.00114 |

Note: Valid combinations are those products in mass production or will be in mass production. Consult your Apacer sales representative to confirm availability of valid combinations and to determine availability of new combinations.

Revision History

| Revision | Description | Date |
|----------|---|-----------|
| 0.1 | Preliminary release | 6/26/2019 |
| 0.2 | - Updated 4.7 Power Failure Management and 4.10 SLC-liteX - Revised MTBF from >3,000,000 hours to >1,000,000 hours on Specifications Overview page and 3.4 Mean Time Between Failures (MTBF) | 7/3/2019 |
| 1.0 | Official release | 3/16/2020 |
| 1.1 | - Changed MTBF from >1,000,000 hours to >3,000,000 hours - Updated Table 3-1 by changing max LBA to total LBA | 6/3/2020 |
| 1.2 | - Modified the wrong model name appearing at 3.7 LED Indicator Behavior - Updated the description of 4.8 Bad Block Management | 8/4/2020 |
| 1.3 | Updated 7.1 Product Code Designations by changing the description of code 5-6 to UH110-UFD1 | 3/19/2021 |
| 1.4 | Removed Hyper Cache Technology support | 9/29/2021 |

Global Presence

Taiwan (Headquarters)

Apacer Technology Inc.

1F., No.32, Zhongcheng Rd., Tucheng Dist.,
New Taipei City 236, Taiwan R.O.C.
Tel: 886-2-2267-8000
Fax: 886-2-2267-2261
amtsales@apacer.com

Japan

Apacer Technology Corp.

6F, Daiyontamachi Bldg., 2-17-12, Shibaura, Minato-Ku,
Tokyo, 108-0023, Japan
Tel: 81-3-5419-2668
Fax: 81-3-5419-0018
jpservices@apacer.com

China

Apacer Electronic (Shanghai) Co., Ltd

Room D, 22/FL, No.2, Lane 600, JieyunPlaza,
Tianshan RD, Shanghai, 200051, China
Tel: 86-21-6228-9939
Fax: 86-21-6228-9936
sales@apacer.com.cn

U.S.A.

Apacer Memory America, Inc.

46732 Lakeview Blvd., Fremont, CA 94538
Tel: 1-408-518-8699
Fax: 1-510-249-9551
sa@apacerus.com

Europe

Apacer Technology B.V.

Science Park Eindhoven 5051 5692 EB Son,
The Netherlands
Tel: 31-40-267-0000
Fax: 31-40-290-0686
sales@apacer.nl

India

Apacer Technologies Pvt Ltd,

1874, South End C Cross, 9th Block Jayanagar,
Bangalore-560069, India
Tel: 91-80-4152-9061/62
Fax: 91-80-4170-0215
sales_india@apacer.com