

RoHS Compliant

USB Flash Drive

EH322 Product Specifications



January 17, 2020

Version 1.0



Apacer Technology Inc.

1F, No.32, Zhongcheng Rd., Tucheng Dist., New Taipei City, Taiwan, R.O.C

Tel: +886-2-2267-8000 Fax: +886-2-2267-2261

www.apacer.com

Specifications Overview:

- **USB3.0 Super Speed compatible, and backward compatible with USB2.0 & interface**
 - USB3.0 max. transfer rate: 5.0 Gbps
 - Backward compatible with 480Mbps & 12 Mbps
- **Capacity**
 - 8 GB
- **Performance***
 - Sequential read: Up to 95 MB/sec
 - Sequential write: Up to 29 MB/sec
- **Flash Management**
 - Flash bad-block management
 - Built-in hardware ECC
 - Power saving implemented
 - Wear-leveling algorithms
 - S.M.A.R.T.
 - Power Failure Management
- **NAND Flash Type: MLC**
- **Endurance (in Terabytes Written: TBW)**
 - 8 GB: 6 TBW
- **Temperature Range**
 - Operating: 0°C to 70°C
 - Storage: -40°C to 100°C
- **Power Consumption***
 - Operating voltage: 5V
 - Active mode: 150 mA
 - Idle mode: 50 mA
- **OS Support**
 - Windows: WinXP/7 or later
 - Mac: 10.2.8 or later
 - Linux: 2.4.10 or later
- **USB Bus-Powered Capability**
- **LED Indicators for Drive Behavior**
- **Dimensions: 55.29 x 18.00 x 8.50, unit: mm**
- **RoHS Compliant**

*The values for performances and power consumptions presented are typical and may vary depending on flash configurations or platform settings.

Table of Contents

1. General Descriptions	3
1.1 Performance-optimized USB Controller	3
1.1.1 Power Saving Implemented	3
1.1.2 Program RAM Architect	3
1.1.3 Error Correction Code (ECC).....	3
1.1.4 Flash Block Management	3
1.1.5 Wear-Leveling Algorithms.....	3
1.1.6 S.M.A.R.T.	4
1.1.7 Power Failure Management.....	4
2. General Specifications.....	5
2.1 Product Specifications	5
2.2 Endurance	5
2.3 LED Indicator Behavior.....	6
3. Absolute Maximum Rating	7
4. Physical Characteristics.....	8
5. Product Ordering Information.....	9

1. General Descriptions

Apacer USB3.0 Handy Flash Drive EH322 is ultra high-performance flash disk drive designed offering portable storage solutions or external memory expansion. This new generation USB flash drive is compatible with the latest USB specification – USB3.0 Super Speed, with a maximum transfer rate of 5.0 Gbps. The connector is backward employable with USB2.0 and USB1.1 interfaces as well. With compliance with USB3.0 specification, this USB drive can deliver up to 95MB/s outstanding performance. Reliability wise, the USB comes with built-in hardware ECC to ensure data integrity. This product is well suited for portable flash storage applications while operating at minimal power consumption.

1.1 Performance-optimized USB Controller

1.1.1 Power Saving Implemented

The internal controller of the USB model is designed with power saving implementations, allowing the device to operate at low power consumption.

1.1.2 Program RAM Architect

The internal Program RAM implementation allows the host to upgrade firmware codes anytime when needed.

1.1.3 Error Correction Code (ECC)

Flash memory cells can deteriorate with use, which might lead to random bit errors in the stored data. Thus, this USB applies the BCH ECC Algorithm, which can detect and correct errors occurring during Read process, ensure data to be read correctly, as well as protect data from corruption. This device can correct up to 24bit/1K data.

1.1.4 Flash Block Management

Current production technology is unable to guarantee total reliability of NAND flash memory array. When a flash memory device leaves factory, it comes with a minimal number of initial bad blocks during production or out-of-factory as there is no currently known technology that produce flash chips free of bad blocks. In addition, bad blocks may develop during program/erase cycles. When host performs program/erase command on a block, bad block may appear in Status Register. Since bad blocks are inevitable, the solution is to keep them in control. Apacer flash devices are programmed with ECC and block mapping technique to reduce invalidity or error. Once bad blocks are detected, data in those blocks will be transferred to free blocks and error will be corrected by designated algorithms.

1.1.5 Wear-Leveling Algorithms

Flash memory devices differ from Hard Disk Drives (HDDs) in terms of how blocks are utilized. For HDDs, when a change is made to stored data, like erase or update, the controller mechanism on HDDs will perform overwrites on blocks. Unlike HDDs, flash blocks cannot be overwritten and each P/E cycle wears down the lifespan of blocks gradually. Repeatedly program/erase cycles performed on the same memory cells will eventually cause some blocks to age faster than others. This would bring flash storages to their end of service term sooner. Wear leveling is an important mechanism that level out the wearing of blocks so that the wearing-down of blocks can be almost evenly distributed. This will increase the lifespan of flash drives. Commonly used wear leveling types are Static and Dynamic.

1.1.6 S.M.A.R.T.

S.M.A.R.T. is an abbreviation for Self-Monitoring, Analysis and Reporting Technology, a self-monitoring system that provides indicators of drive health as well as potential disk problems. It serves as a warning for users from unscheduled downtime by monitoring and displaying critical drive information. Ideally, this should allow taking proactive actions to prevent drive failure and make use of S.M.A.R.T. information for future product development reference.

1.1.7 Power Failure Management

Power Failure Management plays a crucial role when power supply becomes unstable. Power disruption may occur when users are storing data into the SSD, leading to instability in the drive. However, with Power Failure Management, a firmware protection mechanism will be activated to scan pages and blocks once power is resumed. Valid data will be transferred to new blocks for merging and the mapping table will be rebuilt. Therefore, data reliability can be reinforced, preventing damage to data stored in the NAND Flash.

2. General Specifications

2.1 Product Specifications

Table 2-1 Product Specifications

Item		Specifications	
Interface		Super-speed USB3.0 compliant; backward compatible with USB2.0 and USB1.1	
Performance*			8GB
		Read	95
		Write	29
Power consumption**			8GB
		Active	150
		Idle	50
MTBF		1,000,000 hours	
Temperature	Operating	0°C to 70°C	
	Storage	-40°C to 100°C	

Note:

Results may vary from flash configurations or host system settings.

*Sequential performance is based on CrystalDiskMark 5.2.1 with file size 1,000MB.

**Active power is an average power measurement performed using CrystalDiskMark with 128KB sequential read/write transfers.

2.2 Endurance

The endurance of a storage device is predicted by TeraBytes Written based on several factors related to usage, such as the amount of data written into the drive, block management conditions, and daily workload for the drive. Thus, key factors, such as Write Amplifications and the number of P/E cycles, can influence the lifespan of the drive.

Table 2-2 Endurance Specifications

Capacity	TeraBytes Written
8 GB	6

Note:

- The estimated values are based on sequential write behavior. (Apacer EDTest Tool, test mode – sequential data pattern – 100.00% of disk space)
- Flash vendor guaranteed MLC P/E cycle: Toshiba - 3K.
- The WLE/WAF values may vary with the real application on user platform.
- 1 Terabyte = 1,000 GB.

2.3 LED Indicator Behavior

The behavior of the EH322 LED indicator is described in Table 2-3.

Table 2-3 LED Behavior

Location	LED Color	Description
As indicated by the red marker below	Blue	LED blinks when the drive is being accessed such as power on, read or write. The blink frequency is 50ms switch H to L and loop.



3. Absolute Maximum Rating

Caution: Absolute Maximum Stress Ratings – Applied conditions greater than those listed under “Absolute Maximum Stress Ratings” may cause permanent damage to the device. This is a stress rating only and functional operation of the device at these conditions or conditions greater than those defined in the operational sections of this data sheet is not implied. Exposure to absolute maximum stress rating conditions may affect device reliability.

Table 3-1 Absolute Stress Rating

Item	Range
Supply Voltage	5V \pm 5% (4.75-5.25V)
Required Power Supply	4.5-5.5V
Operating Temperature	0°C to 70°C

4. Physical Characteristics

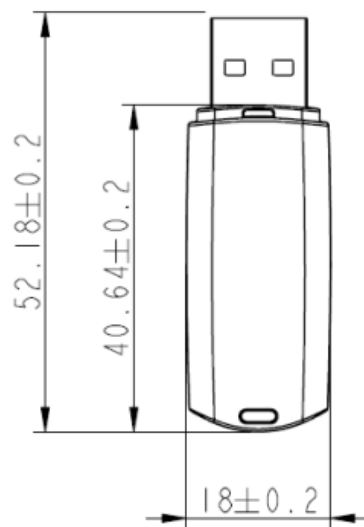
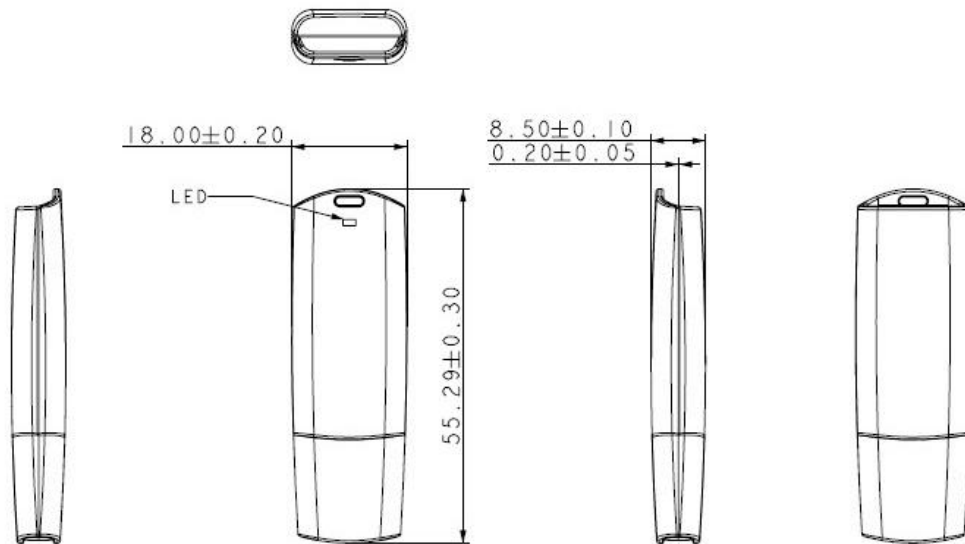

5. Product Ordering Information

Capacity	Part Number
8GB	APHA008GA20CG-3TM

Note: Valid combinations are those products in mass production or will be in mass production. Consult your Apacer sales representative to confirm availability of valid combinations and to determine availability of new combinations.

Revision History

Revision	Description	Date
1.0	Initial release	1/17/2020

Global Presence

Taiwan (Headquarters)

Apacer Technology Inc.

1F., No.32, Zhongcheng Rd., Tucheng Dist.,
New Taipei City 236, Taiwan R.O.C.
Tel: 886-2-2267-8000
Fax: 886-2-2267-2261
amtsales@apacer.com

U.S.A.

Apacer Memory America, Inc.

46732 Lakeview Blvd., Fremont, CA 94538
Tel: 1-408-518-8699
Fax: 1-510-249-9551
sa@apacerus.com

Japan

Apacer Technology Corp.

6F, Daiyontamachi Bldg., 2-17-12, Shibaura, Minato-Ku,
Tokyo, 108-0023, Japan
Tel: 81-3-5419-2668
Fax: 81-3-5419-0018
jpservices@apacer.com

Europe

Apacer Technology B.V.

Science Park Eindhoven 5051 5692 EB Son,
The Netherlands
Tel: 31-40-267-0000
Fax: 31-40-290-0686
sales@apacer.nl

China

Apacer Electronic (Shanghai) Co., Ltd

Room D, 22/FL, No.2, Lane 600, JieyunPlaza,
Tianshan RD, Shanghai, 200051, China
Tel: 86-21-6228-9939
Fax: 86-21-6228-9936
sales@apacer.com.cn

India

Apacer Technologies Pvt Ltd,

1874, South End C Cross, 9th Block Jayanagar,
Bangalore-560069, India
Tel: 91-80-4152-9061/62
Fax: 91-80-4170-0215
sales_india@apacer.com