

RoHS Recast Compliant  
**SATA-Disk Module 7-M**

SDM7-M 7P/180D LP2(H) Product Specifications



August 24, 2022

Version 1.3



**Apacer Technology Inc.**

1F, No.32, Zhongcheng Rd., Tucheng Dist., New Taipei City, Taiwan, R.O.C

Tel: +886-2-2267-8000 Fax: +886-2-2267-2261

[www.apacer.com](http://www.apacer.com)

## Specifications Overview:

- **Compliance with SATA Revision 3.1**
  - SATA 6 Gb/s interface
  - ATA-8 command set
  - Backward compatible with SATA 1.5/3 Gb/s
- **Capacity**
  - 8, 16, 32, 64 GB
- **Performance<sup>1</sup>**
  - Burst read/write: 600 MB/sec
  - Sequential read: Up to 135 MB/sec
  - Sequential write: Up to 90 MB/sec
  - Random read (4K): Up to 25,000 IOPS
  - Random write (4K): Up to 22,000 IOPS
- **Flash Management**
  - Built-in hardware ECC
  - Global Wear Leveling
  - Flash bad-block management
  - Flash Translation Layer: Page Mapping
  - S.M.A.R.T.
  - Power Failure Management
  - ATA Secure Erase
  - TRIM
- **DRAM Cache for Enhanced Random Performance**
- **Reliability**
  - Thermal Sensor
  - Thermal Throttling (optional)
- **NAND Flash Type: MLC**
- **MTBF: >1,000,000 hours**
- **Endurance (in Terabytes Written: TBW)**
  - 8 GB: 19 TBW
  - 16 GB: 27 TBW
  - 32 GB: 66 TBW
  - 64 GB: 126 TBW
- **Temperature Range**
  - Operating: 0°C to 70°C
  - Storage: -40°C to 100°C
- **Supply Voltage**
  - 5.0 V ± 10%
- **Power Consumption<sup>1</sup>**
  - Active mode: 220 mA
  - Idle mode: 55 mA
- **Connector Type**
  - 7-pin SATA signal connector
  - Power segment options: 2 metal pins on each side of SATA connector or power cable connector
- **Form Factor**
  - SATA Disk Module: 7-pin/180 degree
  - Dimensions (without housing): 33.00 x 29.30 x 8.85, unit: mm
  - Dimensions (with housing): 35.20 x 30.40 x 9.25, unit: mm
- **Power Supply Option: Multi-PowerPath Technology**
  - Cable type: +5V VCC from power cable
  - 7+2 Cable-less type: +5V VCC from the 2 metal pins on both sides of the SATA connector
  - Pin 7 Power Cable-less type: +5V VCC from the 7th pin
- **Write Protect Switch (optional)**
- **LED Indicators for Drive Behavior**
- **RoHS Recast Compliant (Complies with 2011/65/EU Standard)**

Note:

1. Varies from capacities. The values for performances and power consumptions presented are typical and may vary depending on flash configurations or platform settings. The term idle refers to the standby state of the device.

## Table of Contents

<b>1. General Description .....</b>	<b>4</b>
<b>2. Functional Block .....</b>	<b>4</b>
<b>3. Pin Assignments.....</b>	<b>5</b>
3.1 Multi-PowerPath Technology.....	5
3.2 Cable Type .....	5
3.3 7+2 Cable-Less Type .....	6
3.4 Pin 7 Power Cable-Less Type .....	6
<b>4. Product Specifications.....</b>	<b>7</b>
4.1 Capacity.....	7
4.2 Performance .....	7
4.3 Environmental Specifications .....	8
4.4 Mean Time Between Failures (MTBF) .....	8
4.5 Certification and Compliance.....	8
4.6 Endurance .....	8
4.7 LED Indicator Behavior.....	9
<b>5. Flash Management .....</b>	<b>10</b>
5.1 Error Correction/Detection.....	10
5.2 Bad Block Management .....	10
5.3 Global Wear Leveling .....	10
5.4 Flash Translation Layer – Page Mapping.....	10
5.5 ATA Secure Erase.....	10
5.6 Power Failure Management .....	11
5.7 TRIM .....	11
5.8 SATA Power Management.....	11
<b>6. Reliability Features .....</b>	<b>12</b>
6.1 Thermal Sensor .....	12
6.2 Thermal Throttling (optional) .....	12
<b>7. Software Interface .....</b>	<b>13</b>
7.1 Command Set.....	13
7.2 S.M.A.R.T. ....	13
<b>8. Electrical Specifications.....</b>	<b>15</b>

8.1 Operating Voltage.....	15
8.2 Power Consumption .....	15
<b>9. Mechanical Specifications.....</b>	<b>16</b>
9.1 Without Housing .....	16
9.2 With Housing .....	16
9.3 Write Protect Switch (optional) .....	17
<b>10. Product Ordering Information.....</b>	<b>18</b>
10.1 Product Code Designations.....	18
10.2 Valid Combinations.....	19

## 1. General Description

Apacer SDM7-M 7P/180D LP2 (H) (SATA Disk Module 7 7Pin/180 Degree Low Profile 2 (Housing)) is a super-mini industrial SSD module that is made with rigid and flex boards featuring a hinged design that allows the boards to stack for better flexibility and shock absorption. Designed in SATA 6 Gb/s interface, SDM7-M can deliver outstanding performance up to 135 MB/s in reading and 90 MB/s in writing, highly suitable to serve as operating system boot drive or storage media of important data. For data efficiency, the internal controlling unit of the product is engineered with a DRAM as a write cache for enhanced random performance and endurance.

Featuring Apacer Multi-PowerPath technology, SDM7-M provides three methods to supply power to the host either via a conventional cable or cable-less design via pin7 or state-of-art 7+2 pin connector, which in turn offers developers maximum flexibility when it comes to board design. Regarding reliability, SDM7-M is built with a powerful SATA controller that supports on-the-module ECC as well as efficient wear leveling scheme. Besides, the device is equipped with a built-in thermal sensor to monitor the temperature of the SSD via S.M.A.R.T commands and configured with thermal throttling to dynamically adjust frequency scaling to enhance data reliability and provide sustained performance while overheating.

In terms of flash management, SDM7-M adopts the latest page mapping file translation layer and comes with various implementations including power saving modes, wear leveling, flash block management, power failure management, S.M.A.R.T., TRIM, making it a powerful yet compact solution for space-limited design.

Last but not least, SDM7-M can be delivered with Apacer CoreAnalyzer analysis software on request making it possible to quantify the actual workload on application which is critical in evaluating life cycle of host applications.

## 2. Functional Block

Apacer SDM7-M includes a single-chip controller designed with a DRAM and flash media. The controller integrates the flash management unit to support multi-channel, multi-bank flash arrays. Figure 2-1 shows the functional block diagram.

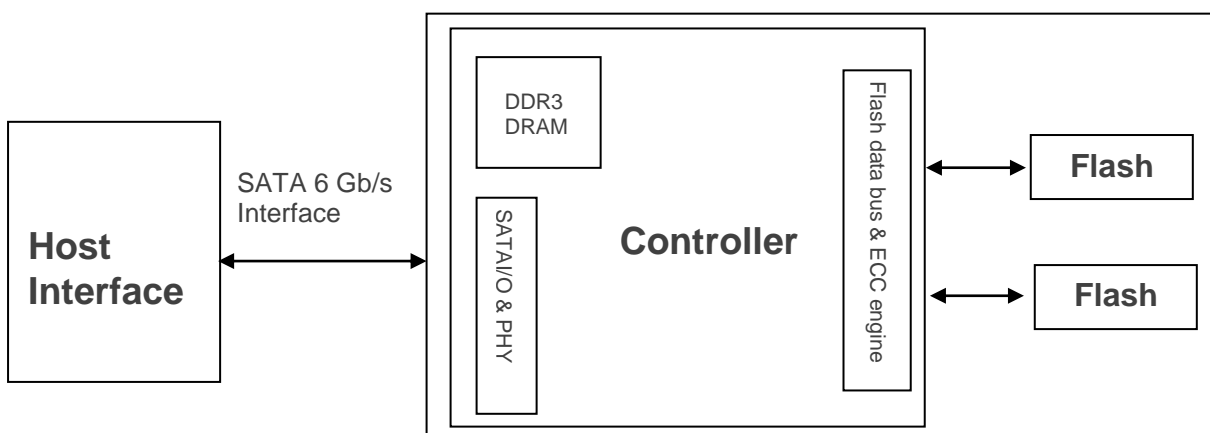

Figure 2-1 Functional Block Diagram

### 3. Pin Assignments

#### 3.1 Multi-PowerPath Technology

Apacer’s patented Multi-PowerPath technology provides a three-option plug-and-play solution for power supply. In addition to using a conventional power cable, power can also be supplied through either Pin7 VCC or state-of-art 7+2 pin connector on the side with cable-less design, allowing an SSD to operate without external power supply, giving it the dual advantages of signal integrity and flexible configuration on the motherboard. With the exclusive, innovative power circuit mechanism, Multi-PowerPath protects miniature SSD from being damaged by overheating even when power is concurrently supplied via the three methods.

#### 3.2 Cable Type

+5V VCC from Power Cable

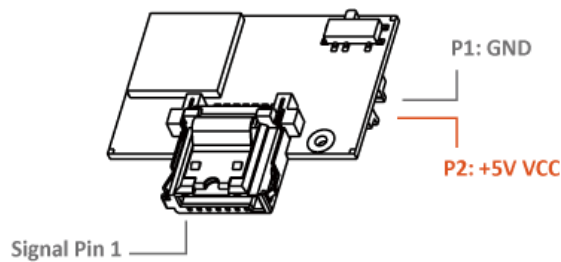

Table 3-1 Signal Segment

Pin	Type	Description
1	GND	Ground
2	A+	Differential Signal Pair A
3	A-	
4	GND	Ground
5	B-	Differential Signal Pair B
6	B+	
7	GND	Ground

Table 3-2 Power Segment

Pin	Type	Description
P1	GND	Ground
P2	VCC	+5V VCC

### 3.3 7+2 Cable-Less Type

+5V VCC from the 2 metal pins on both sides of the SATA connector

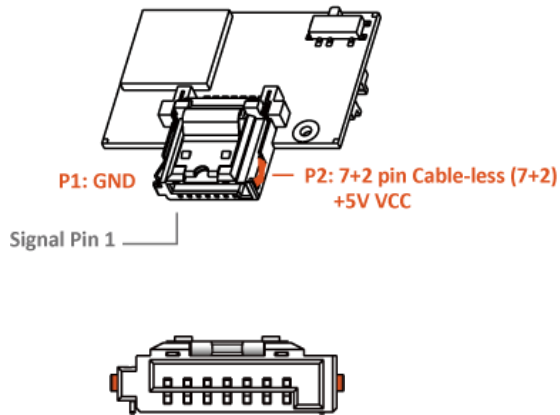

Table 3-3 Signal Segment

Pin	Type	Description
1	GND	Ground
2	A+	Differential Signal Pair A
3	A-	
4	GND	Ground
5	B-	Differential Signal Pair B
6	B+	
7	GND	Ground

Table 3-4 Power Segment (7+2 Cable-less)

Pin	Type	Description
P1	GND	Ground
P2	VCC	+5V VCC

### 3.4 Pin 7 Power Cable-Less Type

+5V VCC from the 7th pin

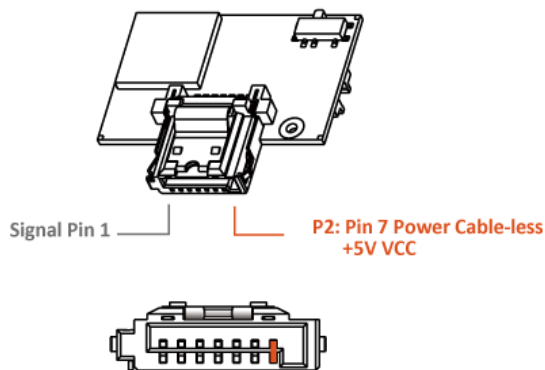

Table 3-5 Signal/Power Segment

Pin	Type	Description
1	GND	Ground
2	A+	Differential Signal Pair A
3	A-	
4	GND	Ground
S5	B-	Differential Signal Pair B
S6	B+	
P2	VCC	+5V VCC

## 4. Product Specifications

### 4.1 Capacity

Capacity specifications of SDM7-M are available as shown in Table 4-1. It lists the specific capacity and the default numbers of heads, sectors and cylinders for each product line.

**Table 4-1 Capacity Specifications**

Capacity	Total bytes	Cylinders	Heads	Sectors	Total LBA
8 GB	8,012,390,400	15,525	16	63	15,649,200
16 GB	16,013,942,784	16,383	16	63	31,277,232
32 GB	32,017,047,552	16,383	16	63	62,533,296
64 GB	64,023,257,088	16,383	16	63	125,045,424

Notes:

- Display of total bytes varies from operating systems.
- 1 GB = 1,000,000,000 bytes; 1 sector = 512 bytes.
- LBA count addressed in the table above indicates total user storage capacity and will remain the same throughout the lifespan of the device. However, the total usable capacity of the SSD is most likely to be less than the total physical capacity because a small portion of the capacity is reserved for device maintenance usages.

### 4.2 Performance

Performance of SDM7-M is listed below in Table 4-2.

**Table 4-2 Performance Specifications**

Capacity \ Performance	8 GB	16 GB	32 GB	64 GB
<b>Sequential Read (MB/s)</b>	120	120	135	135
<b>Sequential Write (MB/s)</b>	25	23	45	90
<b>Random Read IOPS (4K)</b>	15,000	14,000	24,000	25,000
<b>Random Write IOPS (4K)</b>	4,000	5,000	10,000	22,000

Notes:

- Results may differ from various flash configurations or host system setting.
- Sequential read/write is based on CrystalDiskMark 5.2.1 with file size 1,000MB.
- Random read/write is measured using IOMeter with Queue Depth 32.

### 4.3 Environmental Specifications

Environmental specifications of SDM7-M product follow MIL-STD-810 standards as shown in Table 4-3.

**Table 4-3 Environmental Specifications**

Item	Specifications
Operating temp.	0°C to 70°C
Non-operating temp.	-40°C to 100°C
Operating vibration	7.69 Grms, 20~2000 Hz/random (compliant with MIL-STD-810G)
Non-operating vibration	4.02 Grms, 15 ~ 2000 Hz/sine (compliant with MIL-STD-810G)
Operating shock	50(G), 11(ms), half-sine wave
Non-operating shock	1,500(G), 0.5(ms), half-sine wave

Note: This Environmental Specification table indicates the conditions for testing the device. Real world usages may affect the results.

### 4.4 Mean Time Between Failures (MTBF)

Mean Time Between Failures (MTBF) is predicted based on reliability data for the individual components in SDM7-M. The prediction result for SDM7-M is more than 1,000,000 hours.

Note: The MTBF is predicated and calculated based on “Telcordia Technologies Special Report, SR-332, Issue 2” method.

### 4.5 Certification and Compliance

SDM7-M complies with the following standards:

- CE
- FCC
- RoHS Recast
- MIL-STD-810

### 4.6 Endurance

The endurance of a storage device is predicted by TeraBytes Written based on several factors related to usage, such as the amount of data written into the drive, block management conditions, and daily workload for the drive. Thus, key factors, such as Write Amplifications and the number of P/E cycles, can influence the lifespan of the drive.

**Table 4-4 Endurance Specifications**

Capacity	TeraBytes Written
8 GB	19
16 GB	27
32 GB	66
64 GB	126

Notes:

- The measurement assumes the data written to the SSD for test is under a typical and constant rate.
- The measurement follows the standard metric: 1 TB (Terabyte) = 1,000 GB.
- This estimation complies with JEDEC JESD-219, enterprise endurance workload of random data with payload size distribution.

## 4.7 LED Indicator Behavior

The behavior of the SDM7-M LED indicators is described in Table 4-5.

Table 4-5 LED Behavior

Location	LED	Description
LED A	DAS	LED blinks when the drive is being accessed
LED B	Power	LED glows solidly when power is on

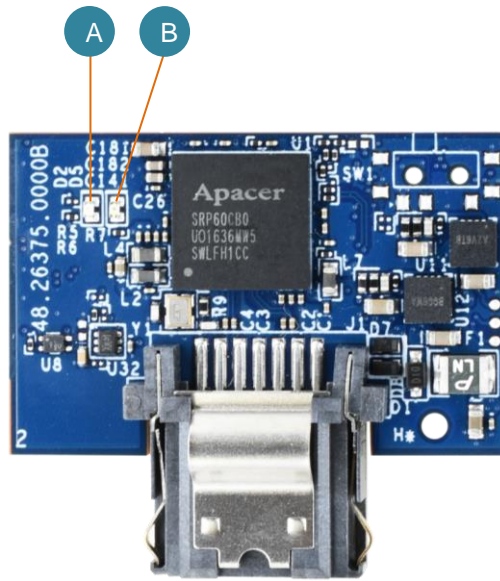

## 5. Flash Management

### 5.1 Error Correction/Detection

SDM7-M implements a hardware ECC scheme, based on the BCH algorithm. It can detect and correct up to 72 bit error in 1K bytes.

### 5.2 Bad Block Management

Current production technology is unable to guarantee total reliability of NAND flash memory array. When a flash memory device leaves factory, it comes with a minimal number of initial bad blocks during production or out-of-factory as there is no currently known technology that produce flash chips free of bad blocks. In addition, bad blocks may develop during program/erase cycles. Since bad blocks are inevitable, the solution is to keep them in control. Apacer flash devices are programmed with ECC, block mapping technique and S.M.A.R.T to reduce invalidity or error. Once bad blocks are detected, data in those blocks will be transferred to free blocks and error will be corrected by designated algorithms.

### 5.3 Global Wear Leveling

Flash memory devices differ from Hard Disk Drives (HDDs) in terms of how blocks are utilized. For HDDs, when a change is made to stored data, like erase or update, the controller mechanism on HDDs will perform overwrites on blocks. Unlike HDDs, flash blocks cannot be overwritten and each P/E cycle wears down the lifespan of blocks gradually. Repeatedly program/erase cycles performed on the same memory cells will eventually cause some blocks to age faster than others. This would bring flash storages to their end of service term sooner. Global wear leveling is an important mechanism that levels out the wearing of all blocks so that the wearing-down of all blocks can be almost evenly distributed. This will increase the lifespan of SSDs.

### 5.4 Flash Translation Layer – Page Mapping

Page mapping is an advanced flash management technology whose essence lies in the ability to gather data, distribute the data into flash pages automatically, and then schedule the data to be evenly written. Page-level mapping uses one page as the unit of mapping. The most important characteristic is that each logical page can be mapped to any physical page on the flash memory device. This mapping algorithm allows different sizes of data to be written to a block as if the data is written to a data pool and it does not need to take extra operations to process a write command. Thus, page mapping is adopted to increase random access speed and improve SSD lifespan, reduce block erase frequency, and achieve optimized performance and lifespan.

### 5.5 ATA Secure Erase

ATA Secure Erase is an ATA disk purging command currently embedded in most of the storage drives. Defined in ATA specifications, (ATA) Secure Erase is part of Security Feature Set that allows storage drives to erase all user data areas. The erase process usually runs on the firmware level as most of the ATA-based storage media currently in the market are built-in with this command. ATA Secure Erase can securely wipe out the user data in the drive and protects it from malicious attack.

## 5.6 Power Failure Management

Power Failure Management plays a crucial role when power supply becomes unstable. Power disruption may occur when users are storing data into the SSD, leading to instability in the drive. However, with Power Failure Management, a firmware protection mechanism will be activated to scan pages and blocks once power is resumed. Valid data will be transferred to new blocks for merging and the mapping table will be rebuilt. Therefore, data reliability can be reinforced, preventing damage to data stored in the NAND Flash.

Note: The controller unit of this product model is designed with a DRAM as a write cache for improved performance and data efficiency. Though unlikely to happen in most cases, the data cached in the volatile DRAM might be potentially affected if a sudden power loss takes place before the cached data is flushed into non-volatile NAND flash memory.

## 5.7 TRIM

TRIM, though in capital letters usually, is a memory computation command rather than an abbreviation. It is mainly a SATA command that enables the operating system to inform the SSD (Solid State Drive) which blocks of previously stored data are no longer valid, due to erases by the host or operating system, such as file deletions or disk formatting. Once notified, SSD will begin the discard of the invalid LBAs and retain more space for itself, in fact, the discarded is no longer recoverable.

When an LBA is replaced by the operating system, as with overwrite of a file, the SSD is informed that the originally occupied LBA is determined as no longer in use or invalid. The SSD will not save those blocks in garbage collected sectors. Noticeably, a file deletion command by host or operating system never actually erases the actual content, but marks the file as deleted. This issue is even specifically noticeable for flash based memory devices, such as SSDs. In fact, an SSD will keep garbage collecting the invalid, previously occupied LBAs, if it is not informed that these LBAs can be erased. Thus, the SSD would experience a significant performance downfall.

## 5.8 SATA Power Management

By complying with SATA 6 Gb/s specifications, the SSD supports the following SATA power saving modes:

- ACTIVE: PHY ready, full power, TX & RX operational
- PARTIAL: Reduces power, resumes in under 10  $\mu$ s (microseconds)
- SLUMBER: Reduces power, resumes in under 10 ms (milliseconds)
- HIPM: Host-Initiated Power Management
- DIPM: Device-Initiated Power Management
- AUTO-SLUMBER: Automatic transition from partial to slumber.

Note: The behaviors of power management features would depend on host/device settings.

## 6. Reliability Features

### 6.1 Thermal Sensor

Apacer Thermal Sensor is a digital temperature sensor with serial interface. By using designated pins for transmission, storage device owners are able to read temperature data.

### 6.2 Thermal Throttling (optional)

Thermal throttling can monitor the temperature of the SSD equipped with a built-in thermal sensor via S.M.A.R.T. commands. This method can ensure the temperature of the device stays within temperature limits by drive throttling, i.e. reducing the speed of the drive when the device temperature reaches the threshold level, so as to prevent overheating, guarantee data reliability, and prolong product lifespan. When the temperature exceeds the maximum threshold level, thermal throttling will be triggered to reduce performance step by step to prevent hardware components from being damaged. Performance is only permitted to drop to the extent necessary for recovering a stable temperature to cool down the device's temperature. Once the temperature decreases to the minimum threshold value, transfer speeds will rise back to its optimum performance level.

## 7. Software Interface

### 7.1 Command Set

Table 7-1 Command Set

Code	Command	Code	Command
E5h	Check Power Mode	F3h	Security Erase Prepare
06h	Data Set Management	F4h	Security Erase Unit
90h	Execute Device Diagnostic	F5h	Security Freeze Lock
E7h	Flush Cache	F1h	Security Set Password
EAh	Flush Cache EXT	F2h	Security Unlock
ECh	Identify Device	70h	Seek
E3h	Idle	EFh	Set Features
E1h	Idle Immediate	C6h	Set Multiple Mode
91h	Initialize Device Parameters	E6h	Sleep
C8h	Read DMA	B0h	SMART
25h	Read DMA EXT	E2h	Standby
C4h	Read Multiple	E0h	Standby Immediate
29h	Read Multiple EXT	CAh	Write DMA
20h	Read Sector	35h	Write DMA EXT
24h	Read Sector EXT	C5h	Write Multiple
40h	Read Verify Sectors	39h	Write Multiple EXT
42h	Read Verify Sectors EXT	30h	Write Sector
10h	Recalibrate	34h	Write Sector EXT
F6h	Security Disable Password		

### 7.2 S.M.A.R.T.

S.M.A.R.T. is an abbreviation for Self-Monitoring, Analysis and Reporting Technology, a self-monitoring system that provides indicators of drive health as well as potential disk problems. It serves as a warning for users from unscheduled downtime by monitoring and displaying critical drive information. Ideally, this should allow taking proactive actions to prevent drive failure and make use of S.M.A.R.T. information for future product development reference.

Apacer devices use the standard SMART command B0h to read data out from the drive to activate our S.M.A.R.T. feature that complies with the ATA/ATAPI specifications. S.M.A.R.T. Attribute IDs shall include initial bad block count, total later bad block count, maximum erase count, average erase count, power on hours and power cycle. When the S.M.A.R.T. Utility running on the host, it analyzes and reports the disk status to the host before the device reaches in critical condition.

Note: Attribute IDs may vary from product models due to various solution design and supporting capabilities.

Apacer memory products come with S.M.A.R.T. commands and subcommands for users to obtain information of drive status and to predict potential drive failures. Users can take advantage of the following commands/subcommands to monitor the health of the drive.

**Table 7-2 SMART Subcommand Set**

Code	SMART Subcommand
D0h	READ DATA
D1h	READ ATTRIBUTE THRESHOLDS
D2h	ENABLE/DISABLE ATTRIBUTE AUTOSAVE
D4h	EXECUTE OFF-LINE IMMEDIATE
D5h	SMART READ LOG
D6h	SMART WRITE LOG
D8h	ENABLE OPERATIONS
D9h	DISABLE OPERATIONS
DAh	RETURN STATUS

**Table 7-3 General SMART Attribute Structure**

Byte	Description
0	ID (Hex)
1 – 2	Status Flag
3	Value
4	Worst
5*-11	Raw Data

\*Byte 5: LSB

**Table 7-4 SMART Attribute ID List**

ID (Hex)	Attribute Name	Note
9 (0x09)	POWER-ON HOURS	General
12 (0x0C)	POWER CYCLE COUNT	General
163 (0xA3)	MAX. ERASE COUNT	General
164 (0xA4)	AVG. ERASE COUNT	General
166 (0xA6)	TOTAL LATER BAD BLOCK COUNT	General
167 (0xA7)	SSD PROTECT MODE	0: R/W, 3: Read Only
168 (0xA8)	SATA PHY ERROR COUNT	Command Fail Count
175 (0xAF)	BAD CLUSTER TABLE COUNT	ECC Fail Count
192 (0xC0)	UNEXPECTED POWER LOSS COUNT	ATA Standby Command
194 (0xC2)	TEMPERATURE	PCB Temperature
241 (0xF1)	TOTAL SECTORS OF WRITE	LBA

## 8. Electrical Specifications

### 8.1 Operating Voltage

Table 8-1 lists the supply voltage for SDM7-M.

Table 8-1 Operating Range

Item	Range
Supply Voltage	5V ± 10%

### 8.2 Power Consumption

Table 8-2 lists the power consumption for SDM7-M.

Table 8-2 Power Consumption

Mode \ Capacity	8 GB	16 GB	32 GB	64 GB
Active (mA)	145	145	170	220
Idle (mA)	55	55	55	55

Notes:

- All values are typical and may vary depending on flash configurations or host system settings.
- Active power is an average power measurement performed using CrystalDiskMark with 128KB sequential read/write transfers.

## 9. Mechanical Specifications

### 9.1 Without Housing

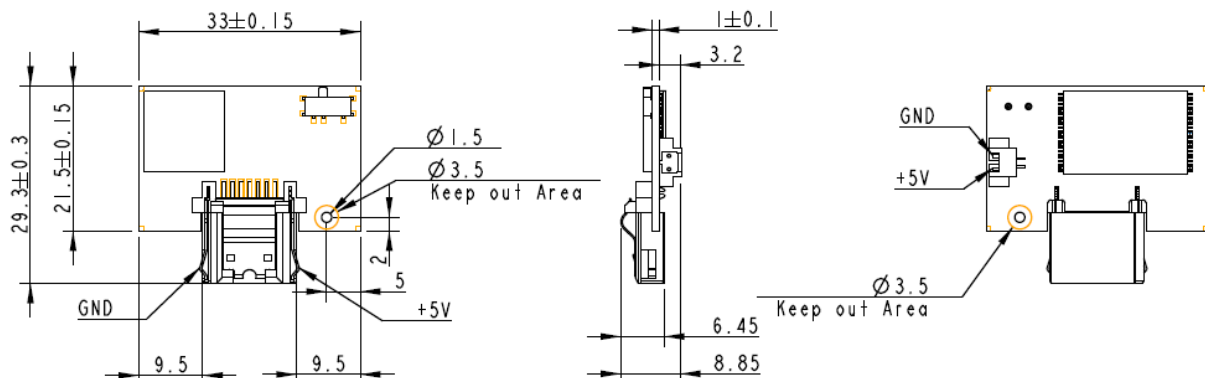

Figure 9-1 Dimensions – Without Housing

### 9.2 With Housing

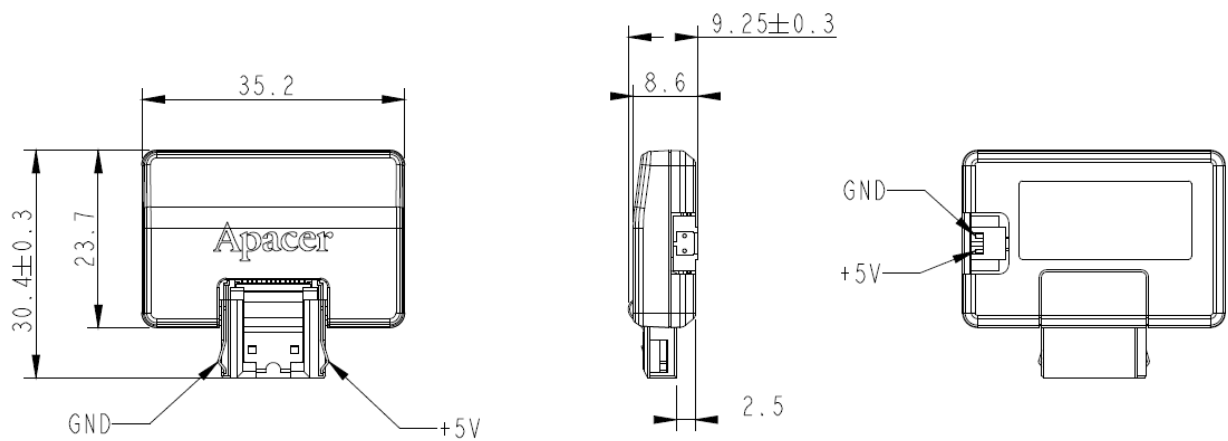

Figure 9-2 Dimensions – With Housing

Unit: mm

### 9.3 Write Protect Switch (optional)

Apacer implements the Virtual Write scheme that allows write commands to go through the flash controller and data temporarily stored, but no data has been actually written into the flash. Once the system is reset and rebooted, the temporarily stored data will be lost and nowhere to be found in the system. Since the Virtual Write scheme runs at device level, it requires no software or driver installation and is independent from the host OS.

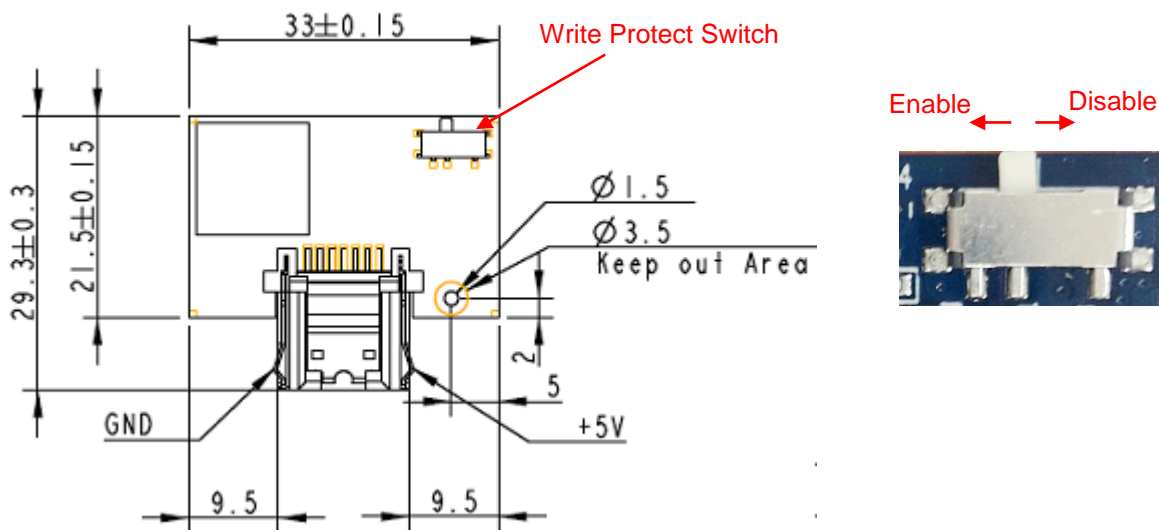
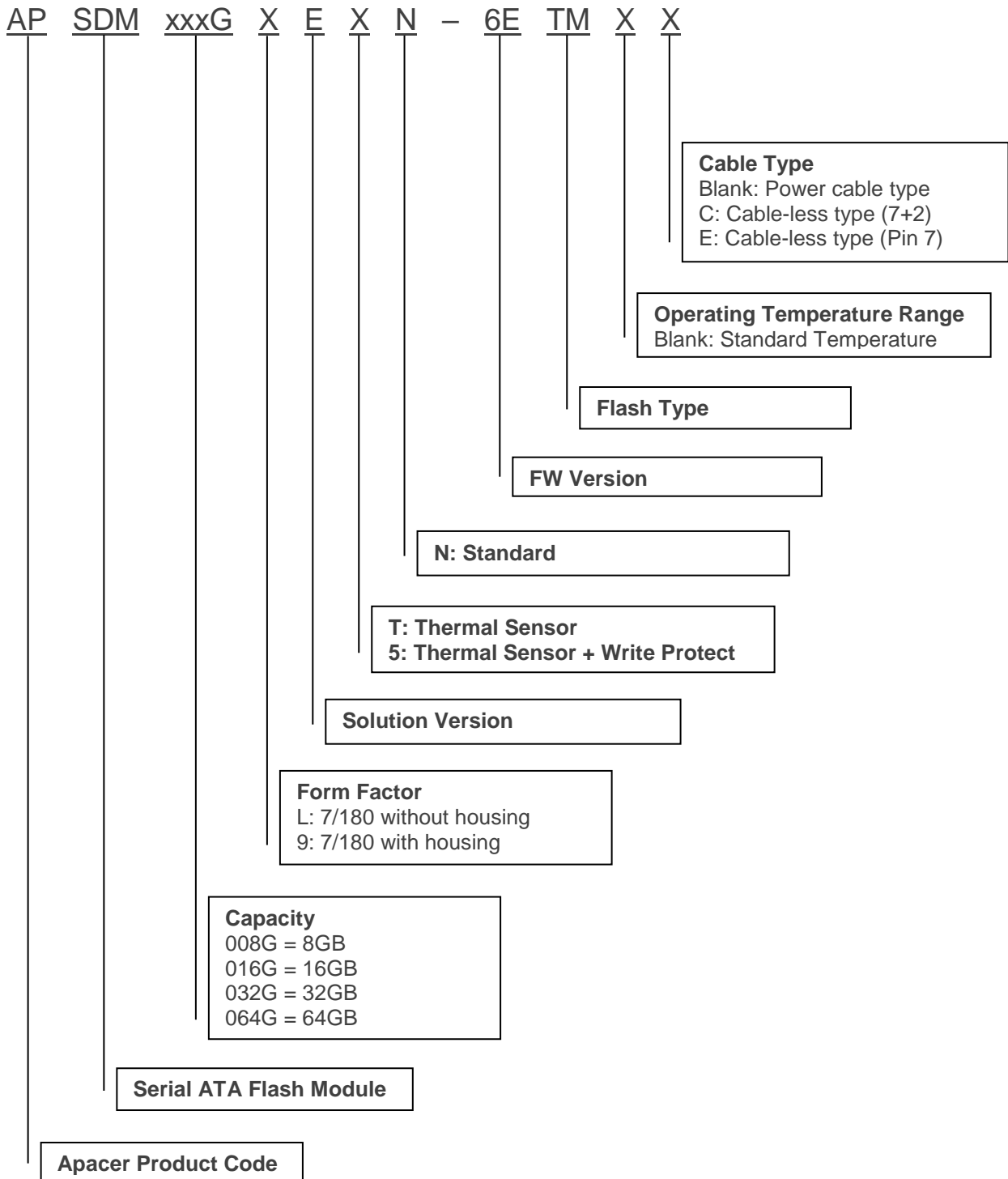

Figure 9-3 Write Protect Switch

## 10. Product Ordering Information

### 10.1 Product Code Designations



## 10.2 Valid Combinations

### A. Cable type: +5V VCC from power cable

#### 10.2.1 Without Write Protect

Capacity	Without Housing	With Housing
8GB	APSDM008GLETN-6ETM	APSDM008G9ETN-6ETM
16GB	APSDM016GLETN-6ETM	APSDM016G9ETN-6ETM
32GB	APSDM032GLETN-6ETM	APSDM032G9ETN-6ETM
64GB	APSDM064GLETN-6ETM	APSDM064G9ETN-6ETM

#### 10.2.2 With Write Protect

Capacity	Without Housing	With Housing
8GB	APSDM008GLE5N-6ETM	APSDM008G9E5N-6ETM
16GB	APSDM016GLE5N-6ETM	APSDM016G9E5N-6ETM
32GB	APSDM032GLE5N-6ETM	APSDM032G9E5N-6ETM
64GB	APSDM064GLE5N-6ETM	APSDM064G9E5N-6ETM

### B. 7+2 Cable-less type: +5V VCC from the 2 metal pins on both sides of the SATA connector

#### 10.2.3 Without Write Protect

Capacity	Without Housing	With Housing
8GB	APSDM008GLETN-6ETMC	APSDM008G9ETN-6ETMC
16GB	APSDM016GLETN-6ETMC	APSDM016G9ETN-6ETMC
32GB	APSDM032GLETN-6ETMC	APSDM032G9ETN-6ETMC
64GB	APSDM064GLETN-6ETMC	APSDM064G9ETN-6ETMC

#### 10.2.4 With Write Protect

Capacity	Without Housing	With Housing
8GB	APSDM008GLE5N-6ETMC	APSDM008G9E5N-6ETMC
16GB	APSDM016GLE5N-6ETMC	APSDM016G9E5N-6ETMC
32GB	APSDM032GLE5N-6ETMC	APSDM032G9E5N-6ETMC
64GB	APSDM064GLE5N-6ETMC	APSDM064G9E5N-6ETMC

**C. Pin 7 Power Cable-less type: +5V VCC from the 7th pin**

**10.2.5 Without Write Protect**

Capacity	Without Housing	With Housing
8GB	APSDM008GLETN-6ETME	APSDM008G9ETN-6ETME
16GB	APSDM016GLETN-6ETME	APSDM016G9ETN-6ETME
32GB	APSDM032GLETN-6ETME	APSDM032G9ETN-6ETME
64GB	APSDM064GLETN-6ETME	APSDM064G9ETN-6ETME

**10.2.6 With Write Protect**

Capacity	Without Housing	With Housing
8GB	APSDM008GLE5N-6ETME	APSDM008G9E5N-6ETME
16GB	APSDM016GLE5N-6ETME	APSDM016G9E5N-6ETME
32GB	APSDM032GLE5N-6ETME	APSDM032G9E5N-6ETME
64GB	APSDM064GLE5N-6ETME	APSDM064G9E5N-6ETME

**Note:** Valid combinations are those products in mass production or will be in mass production. Consult your Apacer sales representative to confirm availability of valid combinations and to determine availability of new combinations.

## Revision History

Revision	Description	Date
1.0	Official release	7/9/2018
1.1	<ul style="list-style-type: none"> <li>- Added Endurance to Specifications Overview</li> <li>- Added LED Indicators for Drive Behavior to Specifications Overview</li> <li>- Added 4.6 Endurance</li> <li>- Added 4.7 LED Indicator Behavior</li> <li>- Modified the numbering at 6. Reliability Features</li> </ul>	8/7/2018
1.2	<ul style="list-style-type: none"> <li>- Updated technology description for 5.6 Power Failure Management</li> <li>- Updated Power Consumption on Specifications Overview page and 8.2 Power Consumption</li> <li>- Updated 10. Product Ordering Information due to FW change</li> </ul>	12/10/2019
1.3	Modified supply voltage range from $\pm 5\%$ to $\pm 10\%$ on Specifications Overview page and Table 8-1	8/23/2022

## Global Presence

### Taiwan (Headquarters)

#### Apacer Technology Inc.

1F., No.32, Zhongcheng Rd., Tucheng Dist.,  
New Taipei City 236, Taiwan R.O.C.  
Tel: 886-2-2267-8000  
Fax: 886-2-2267-2261  
[amtsales@apacer.com](mailto:amtsales@apacer.com)

### U.S.A.

#### Apacer Memory America, Inc.

46732 Lakeview Blvd., Fremont, CA 94538  
Tel: 1-408-518-8699  
Fax: 1-510-249-9551  
[sa@apacerus.com](mailto:sa@apacerus.com)

### Japan

#### Apacer Technology Corp.

6F, Daiyontamachi Bldg., 2-17-12, Shibaura, Minato-Ku,  
Tokyo, 108-0023, Japan  
Tel: 81-3-5419-2668  
Fax: 81-3-5419-0018  
[jpservices@apacer.com](mailto:jpservices@apacer.com)

### Europe

#### Apacer Technology B.V.

Science Park Eindhoven 5051 5692 EB Son,  
The Netherlands  
Tel: 31-40-267-0000  
Fax: 31-40-290-0686  
[sales@apacer.nl](mailto:sales@apacer.nl)

### China

#### Apacer Electronic (Shanghai) Co., Ltd

Room D, 22/FL, No.2, Lane 600, JieyunPlaza,  
Tianshan RD, Shanghai, 200051, China  
Tel: 86-21-6228-9939  
Fax: 86-21-6228-9936  
[sales@apacer.com.cn](mailto:sales@apacer.com.cn)

### India

#### Apacer Technologies Pvt Ltd,

1874, South End C Cross, 9<sup>th</sup> Block Jayanagar,  
Bangalore-560069, India  
Tel: 91-80-4152-9061/62  
Fax: 91-80-4170-0215  
[sales\\_india@apacer.com](mailto:sales_india@apacer.com)