

RoHS Recast Compliant

SATA-Disk Module 5

SDM5-M 7P/180D Low Profile 2 Product Specifications

November 25th, 2013

Version 1.1



Apacer Technology Inc.

1F, No.32, Zhongcheng Rd., Tucheng Dist., New Taipei City, Taiwan, R.O.C

Tel: +886-2-2267-8000 Fax: +886-2-2267-2261

www.apacer.com

Features:

- **Standard Serial ATA Interface**
 - Serial ATA Revision 3.1
 - SATA 6.0 Gbps
 - ATA-8 command set
 - Backward compatible with SATA 1.5/3.0 Gbps
- **Capacities**
 - 16, 32, 64 GB
- **Performance***
 - Burst read/write: 600 MB/sec
 - Sustained read: up to 305 MB/sec
 - Sustained write: up to 155 MB/sec
- **Intelligent endurance design**
 - Built-in hardware ECC, enabling up to 40-bit correction per 1K bytes
 - Static/dynamic wear-leveling
 - Flash bad-block management
 - S.M.A.R.T.
 - Power Failure Management
 - ATA Secure Erase
 - TRIM
- **NAND Flash Type: MLC**
- **Temperature ranges**
 - Operating: 0°C to 70°C (32 ~ 158°F)
 - Storage: -40°C to 100°C (-40° ~ 212°F)
- **Supply voltage**
 - 5.0 V ± 5%
- **Power consumption (typical)***
 - Active mode: 270 mA@5.0 V
 - Idle mode: 90 mA@5.0 V
- **Connector type**
 - 7-pin SATA signal connector
 - 2-pin power connector for external power cable
- **Form factor**
 - SATA Disk Module: 7-pin/180 degree
 - Dimensions, 33.00x29.30x1.00**unit: mm
- **Shock & Vibration*****
 - Shock:1500 G
 - Vibration: 15 G
- **MTBF: >1,000,000 hours**
- **Write Protect switch (optional)**
- **RoHS Recast compliant**
 - Complies with 2011/65/EU standard

*Varies from capacities. The values for performances and power consumptions presented are typical and may vary depending on flash configurations or platform settings. The term idle refers to the standby state of the device.

**1.00mm indicates the thickness of the module only.

***Non-operating

Table of Contents

1. GENERAL DESCRIPTION	3
2. PIN ASSIGNMENTS	3
3. PRODUCT SPECIFICATIONS	5
3.1 CAPACITY	5
3.2 PERFORMANCE	5
3.3 ENVIRONMENTAL SPECIFICATIONS	5
3.4 MEAN TIME BETWEEN FAILURES (MTBF)	6
3.5 CERTIFICATION AND COMPLIANCE	6
4. FLASH MANAGEMENT	7
4.1 ERROR CORRECTION/DETECTION	7
4.2 BAD BLOCK MANAGEMENT	7
4.3 WEAR LEVELING	7
4.4 POWER FAILURE MANAGEMENT.....	7
4.5 ATA SECURE ERASE	7
4.6 TRIM	8
5. SOFTWARE INTERFACE	9
5.1 COMMAND SET	9
5.2 S.M.A.R.T.	9
6. ELECTRICAL SPECIFICATION	11
7. MECHANICAL SPECIFICATIONS	12
7.1 DIMENSIONS	12
7.2 WRITE PROTECT SWITCH.....	13
8. PRODUCT ORDERING INFORMATION	14
8.1 PRODUCT CODE DESIGNATIONS	14
8.2 VALID COMBINATIONS	15

1. General Description

Apacer's SDM5-M (SATA Disk Module 5-M) is our next generation disk-on-module (DOM) series that offers elevated speed boost and higher error correction capabilities. Built with SATA 6.0 Gb/s interface, SDM5-M delivers higher performance in data transfer than its previous SDM selections, reaching up to 305 MB/s in read and 155 MB/s in write.

With its SATA interface compliance and compact size, this high-speed disk module defines an ideal balance of performance, capacities, reliability and cost. SDM5-M comes in moderate capacities that are suitable to boot industrial applications and light operating systems for specific operations, while with some extra memory space for data storage. The architectural nature of SATA disk module provides higher resistance to external environmental influences and better flexibility for motherboard space.

Regarding data reliability, SDM5-M is built in with powerful ECC engine that can correct up to 40-bit per 1KB data. In addition, the controller unit of this DOM device supports wear-leveling, SMART and power failure management for data integrity. With its trustable reliability, performance and cost effectiveness, Apacer's SDM5-M is definitely the ideal storage or cache solution for embedded and industrial computers, servers and thin clients.

2. Pin Assignments

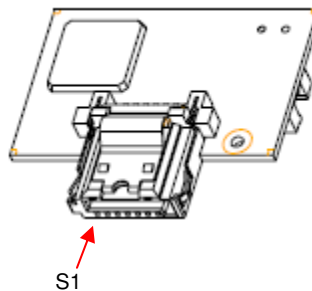
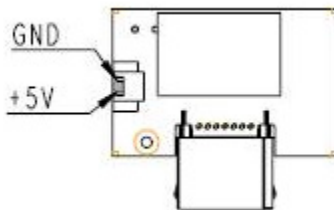

Table 1-3: Signal segment

Pin	Type	Description
S1	GND	
S2	RxP	+ Differential Receive Signal
S3	RxN	- Differential Receive Signal
S4	GND	
S5	TxN	- Differential Transmit Signal
S6	TxP	+ Differential Transmit Signal
S7	GND	

Table 1-4: Power segment

Pin	Signal/Description
P1	VCC (5V)
P2	GND

3. Product Specifications

3.1 Capacity

Capacity specification of SDM5-M is available as shown in Table 3-1. It lists the specific capacity and the default numbers of heads, sectors and cylinders for each product line.

Table 3-1: Capacity specifications

Capacity	Total bytes*	Cylinders	Heads	Sectors	Max LBA
16 GB	16,013,942,784	16,383	16	63	31,277,232
32 GB	32,017,047,552	16,383	16	63	62,533,296
64 GB	64,023,257,088	16,383	16	63	125,045,424

*Display of total bytes varies from file systems, which means not all of the bytes can be used for storage.

**Notes: 1 GB = 1,000,000,000 bytes; 1 sector = 512 bytes.

LBA count addressed in the table above indicates total user storage capacity and will remain the same throughout the lifespan of the device. However, the total usable capacity of the SSD is most likely to be less than the total physical capacity because a small portion of the capacity is reserved for device maintenance usages.

3.2 Performance

Performances of SDM5-M are listed below in table 3-2.

Table 3-2: Performance

Capacity	16 GB	32 GB	64 GB
Performance			
Sustained read (MB/s)	245	250	305
Sustained write (MB/s)	40	85	155

Note: Results may differ from various flash configurations or host system setting

3.3 Environmental Specifications

Environmental specification of SDM5-M product family follows MIL-STD-810 standards as shown in Table 3-3.

Table 3-3 SDM5-M environmental specifications

Item	Specification
Operating temp.	0~70°C
Non-operating temp.	-40~100(°C)
Operating vibration	20~2000(Hz), 7.69 (Grms), random wave, X, Y, Z axis
Non-operating vibration	10~2000(Hz), 15(G), sine wave, X, Y, Z axis
Operating shock	50(G), 11(ms), half-sine wave
Non-operating shock	1500(G), 0.5(ms), half-sine wave

3.4 Mean Time Between Failures (MTBF)

Mean Time Between Failures (MTBF) is predicted based on reliability data for the individual components in SDM5-M. The prediction result for SDM5-M is more than 1,000,000 hours.

Notes about the MTBF:

The MTBF is predicated and calculated based on "Telcordia Technologies Special Report, SR-332, Issue 2" method.

3.5 Certification and Compliance

SDM5-M complies with the following standards:

- CE
- FCC
- RoHS Recast
- MIL-STD-810

4. Flash Management

4.1 Error Correction/Detection

SDM5-M implements a hardware ECC scheme, based on the BCH algorithm. It can detect and correct up to 40-bit error in 1K bytes.

4.2 Bad Block Management

Current production technology is unable to guarantee total reliability of NAND flash memory array. When a flash memory device leaves factory, it comes with a minimal number of initial bad blocks during production or out-of-factory as there is no currently known technology that produce flash chips free of bad blocks. In addition, bad blocks may develop during program/erase cycles. When host performs program/erase command on a block, bad block may appear in Status Register. Since bad blocks are inevitable, the solution is to keep them in control. Apacer flash devices are programmed with ECC, block mapping technique and S.M.A.R.T to reduce invalidity or error. Once bad blocks are detected, data in those blocks will be transferred to free blocks and error will be corrected by designated algorithms.

4.3 Wear Leveling

Flash memory devices differ from Hard Disk Drives (HDDs) in terms of how blocks are utilized. For HDDs, when a change is made to stored data, like erase or update, the controller mechanism on HDDs will perform overwrites on blocks. Unlike HDDs, flash blocks cannot be overwritten and each P/E cycle wears down the lifespan of blocks gradually. Repeatedly program/erase cycles performed on the same memory cells will eventually cause some blocks to age faster than others. This would bring flash storages to their end of service term sooner. Wear leveling is an important mechanism that level out the wearing of blocks so that the wearing-down of blocks can be almost evenly distributed. This will increase the lifespan of SSDs. Commonly used wear leveling types are Static and Dynamic.

4.4 Power Failure Management

Power Failure Management plays a crucial role when experiencing unstable power supply. Power disruption may occur when users are storing data into the SSD. In this urgent situation, the controller would run multiple write-to-flash cycles to store the metadata for later block rebuilding. This urgent operation requires about several milliseconds to get it done. At the next power up, the firmware will perform a status tracking to retrieve the mapping table and resume previously programmed NAND blocks to check if there is any incompleteness of transmission.

4.5 ATA Secure Erase

ATA Secure Erase is an ATA disk purging command currently embedded in most of the storage drives. Defined in ATA specifications, (ATA) Secure Erase is part of Security Feature Set that allows storage drives to erase all user data areas. The erase process usually runs on the firmware level as most of the ATA-based storage media currently in the market are built-in with this command. ATA Secure Erase can securely wipe out the user data in the drive and protects it from malicious attack.

4.6 TRIM

TRIM is a SATA command that helps improve the read/write performance and efficiency of solid-state drives (SSD). The command enables the host operating system to inform SSD controller which blocks contain invalid data, mostly because of the erase commands from host. The invalid will be discarded permanently and the SSD will retain more space for itself.

5. Software Interface

5.1 Command Set

This section defines the software requirements and the format of the commands the host sends to SDM5-M. Commands are issued to SDM5-M by loading the required registers in the command block with the supplied parameters, and then writing the command code to the Command register.

Table 5-1: Command set

Code	Command	Code	Command
E5h	Check Power Mode	F3h	Security Erase Prepare
06h	Data Set Management	F4h	Security Erase Unit
90h	Execute Device Diagnostic	F5h	Security Freeze Lock
E7h	Flush Cache	F1h	Security Set Password
EAh	Flush Cache EXT	F2h	Security Unlock
Ech	Identify Device	70h	Seek
E3h	Idle	Efh	Set Features
E1h	Idle Immediate	C6h	Set Multiple Mode
91h	Initialize Device Parameters	E6h	Sleep
C8h	Read DMA	B0h	SMART
25h	Read DMA EXT	E2h	Standby
C4h	Read Multiple	E0h	Standby Immediate
29h	Read Multiple EXT	Cah	Write DMA
20h	Read Sector	35h	Write DMA EXT
24h	Read Sector EXT	C5h	Write Multiple
40h	Read Verify Sectors	39h	Write Multiple EXT
42h	Read Verify Sectors EXT	30h	Write Sector
10h	Recalibrate	34h	Write Sector EXT
F6h	Security Disable Password		

5.2 S.M.A.R.T.

S.M.A.R.T. is an abbreviation for Self-Monitoring, Analysis and Reporting Technology, a self-monitoring system that provides indicators of drive health as well as potential disk problems. It serves as a warning for users from unscheduled downtime by monitoring and displaying critical drive information. Ideally, this should allow taking proactive actions to prevent drive failure and make use of S.M.A.R.T. information for future product development reference.

Apacer devices use the standard SMART command B0h to read data out from the drive to activate our S.M.A.R.T. feature that complies with the ATA/ATAPI specifications. S.M.A.R.T. Attribute IDs shall

include initial bad block count, total later bad block count, maximum erase count, average erase count, power on hours and power cycle. When the S.M.A.R.T. Utility running on the host, it analyzes and reports the disk status to the host before the device reaches in critical condition.

Note: attribute IDs may vary from product models due to various solution design and supporting capabilities.

Apacer memory products come with S.M.A.R.T. commands and subcommands for users to obtain information of drive status and to predict potential drive failures. Users can take advantage of the following commands/subcommands to monitor the health of the drive.

Code	SMART Subcommand
D0h	READ DATA
D1h	READ ATTRIBUTE THRESHOLDS
D2h	Enable/Disable Attribute Autosave
D4h	Execute Off-line Immediate
D5h	Read Log (optional)
D6h	Write Log (optional)
D8h	Enable Operations
D9h	Disable operations
DAh	Return Status

General SMART attribute structure

Byte	Description
0	ID (Hex)
1 – 2	Status flag
3	Value
4	Worst
5*-11	Raw Data

*Byte 5: LSB

SMART attribute ID list

ID (Hex)	Attribute Name
9 (0x09)	Power-on hours
12 (0x0C)	Power cycle count
163 (0xA3)	Max. erase count
164 (0xA4)	Avg. erase count
166 (0xA6)	Total later bad block count
167 (0xA7)	SSD Protect Mode (vendor specific)
168 (0xA8)	SATA PHY Error Count
175 (0xAF)	Bad Cluster Table Count
192 (0xC0)	Unexpected Power Loss Count
194 (0xC2)	Temperature
241 (0xF1)	Total sectors of write

6. Electrical Specification

Caution: Absolute Maximum Stress Ratings – Applied conditions greater than those listed under “Absolute Maximum Stress Ratings” may cause permanent damage to the device. This is a stress rating only and functional operation of the device at these conditions or conditions greater than those defined in the operational sections of this data sheet is not implied. Exposure to absolute maximum stress rating conditions may affect device reliability.

Table 6-1: Operating range

Ambient Temperature	0 °C to +70 °C
Voltage Supply	4.75-5.25V

Table 6-2: Typical power consumption

Modes \ Capacity	16 GB	32 GB	64 GB
Active (mA)	170	220	270
Idle (mA)	85	90	90

Note: Results may differ from various flash configurations or host system setting

7. Mechanical Specifications

7.1 Dimensions

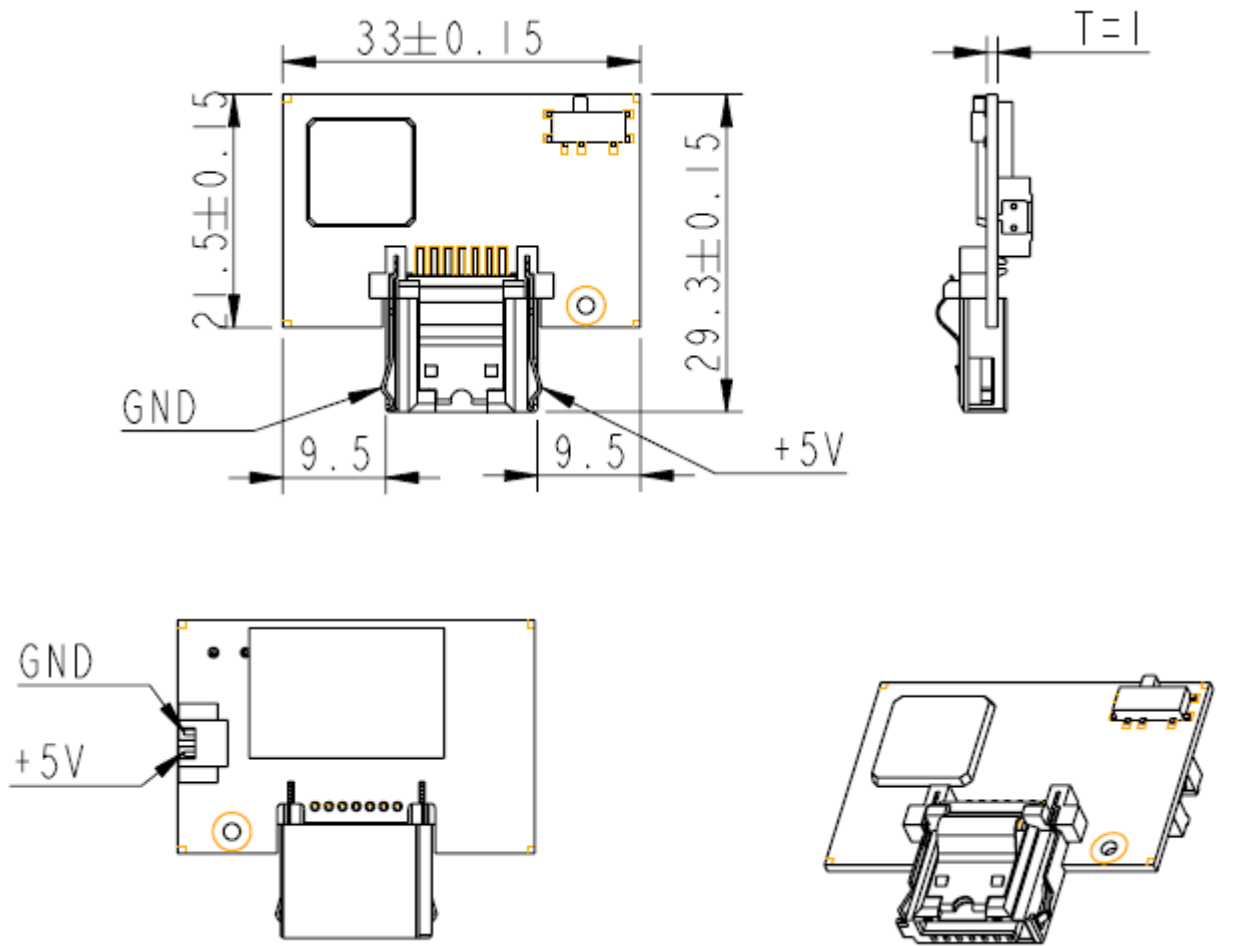

Unit: mm
Tolerance: ± 0.25

7.2 Write Protect Switch

Apacer implements the Virtual Write scheme that allows write commands to go through the flash controller and data temporarily stored, but no data has been actually written into the flash. Once the system is reset and rebooted, the temporarily stored data will be lost and nowhere to be found in the system. Since the Virtual Write scheme runs at device level, it requires no software or driver installation and is independent from the host OS.

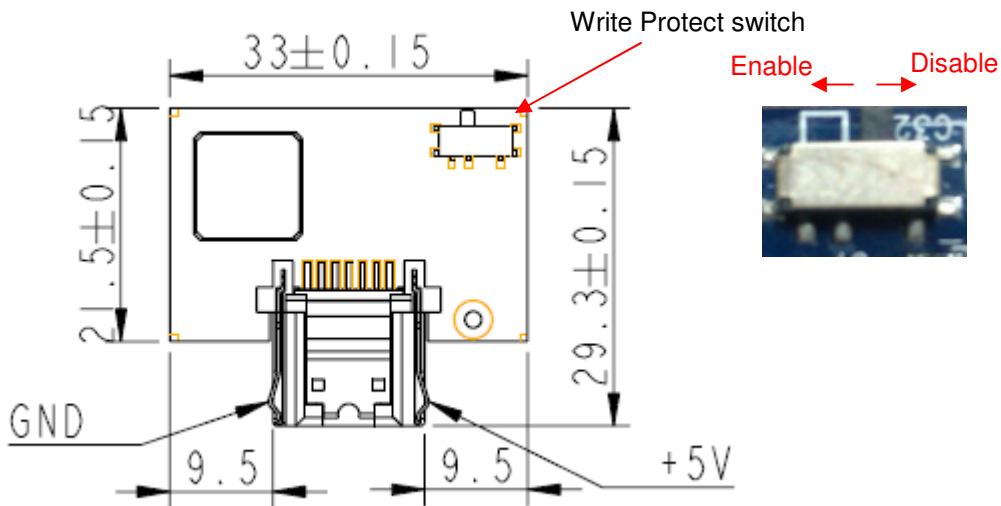

Note: Write Protect is optional.

8. Product Ordering Information

8.1 Product Code Designations

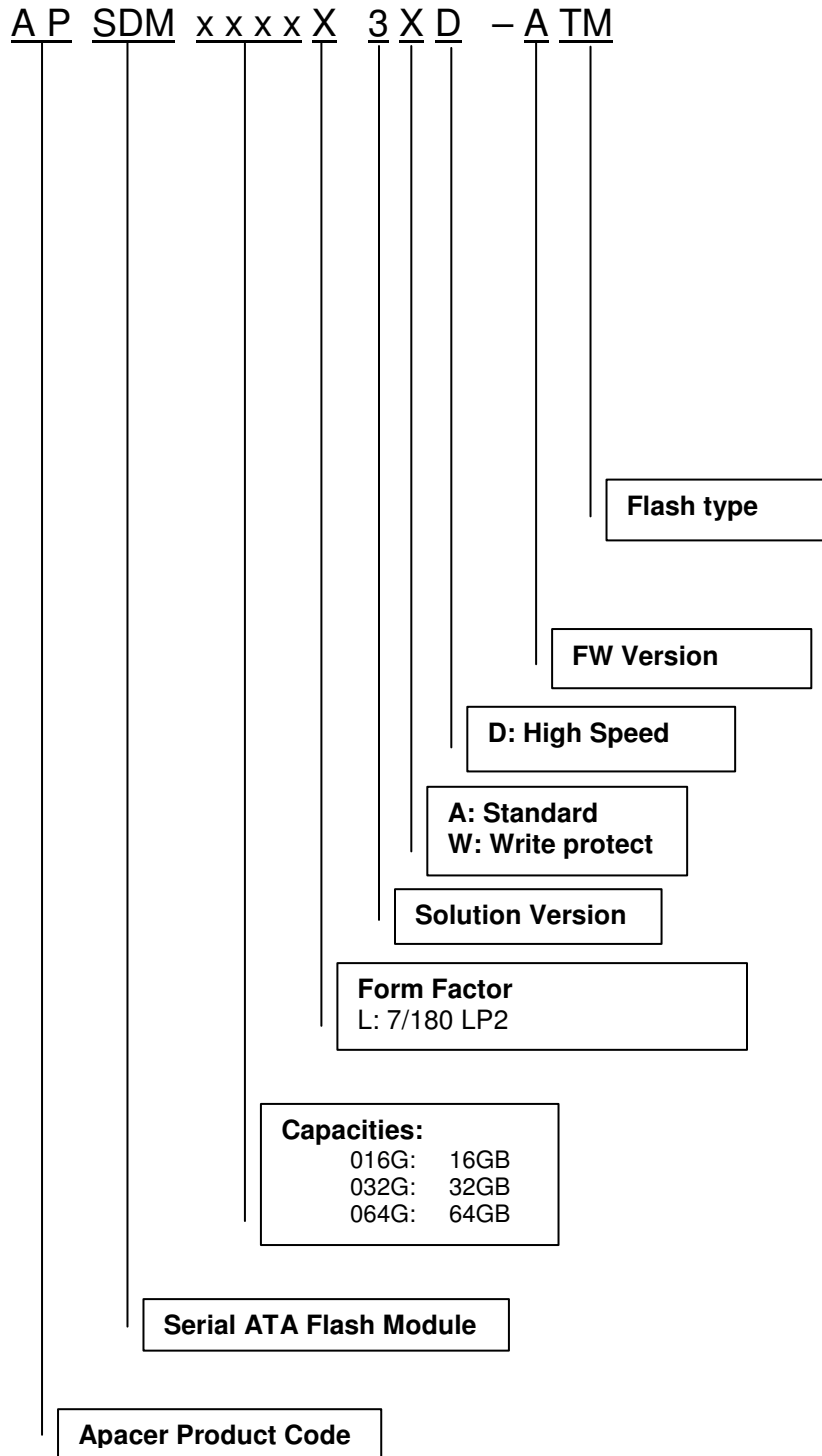

8.2 Valid Combinations

High-Speed 180D LP2

Capacity	Model Number
16GB	APSDM016GL3AD-ATM
32GB	APSDM032GL3AD-ATM
64GB	APSDM064GL3AD-ATM

High-Speed 180D with write protect

Capacity	Model Number
16GB	APSDM016GL3WD-ATM
32GB	APSDM032GL3WD-ATM
64GB	APSDM064GL3WD-ATM

Note: Please consult with Apacer sales representatives for availabilities.

Revision History

Revision	Date	Description	Remark
0.1	06/19/2013	Preliminary release	
1.0	09/09/2013	Official release	
1.1	11/25/2013	Added Write Protect switch option	

Global Presence

Taiwan (Headquarters)	Apacer Technology Inc. Apacer Technology Inc. 1F., No.32, Zhongcheng Rd., Tucheng Dist., New Taipei City 236, Taiwan R.O.C. Tel: 886-2-2267-8000 Fax: 886-2-2267-2261 amtsales@apacer.com
U.S.A.	Apacer Memory America, Inc. 386 Fairview Way, Suite102, Milpitas, CA 95035 Tel: 1-408-518-8699 Fax: 1-408-935-9611 sa@apacerus.com
Japan	Apacer Technology Corp. 5F, Matsura Bldg., Shiba, Minato-Ku Tokyo, 105-0014, Japan Tel: 81-3-5419-2668 Fax: 81-3-5419-0018 jpservices@apacer.com
Europe	Apacer Technology B.V. Science Park Eindhoven 5051 5692 EB Son, The Netherlands Tel: 31-40-267-0000 Fax: 31-40-267-0000#6199 sales@apacer.nl
China	Apacer Electronic (Shanghai) Co., Ltd 1301, No.251,Xiaomuqiao Road, Shanghai, 200032, China Tel: 86-21-5529-0222 Fax: 86-21-5206-6939 sales@apacer.com.cn
India	Apacer Technologies Pvt Ltd, # 535, 1st Floor, 8th cross, JP Nagar 3rd Phase, Bangalore – 560078, India Tel: 91-80-4152-9061 sales_india@apacer.com