

RoHS Recast Compliant

SATA-Disk Module 5

SDM5-M 7P/180D Low Profile Product Specifications

April 2nd, 2014

Version 1.2



Apacer Technology Inc.

1F, No.32, Zhongcheng Rd., Tucheng Dist., New Taipei City, Taiwan, R.O.C

Tel: +886-2-2267-8000 Fax: +886-2-2267-2261

www.apacer.com

Features:

- **Standard Serial ATA 3.1 Revision**
 - Serial ATA 3.1 Revision compliance
 - SATA 6.0 Gbps interface
 - ATA-8 command set
 - Backward compatible with SATA 1.5/3.0 Gbps
- **Capacities**
 - Standard Type: 8, 16, 32 GB
 - High-speed Type: 16, 32, 64 GB (in cable-less type only)
- **Performance***
 - Burst read/write: 600 MB/sec
 - Standard Type:
 - Sustained read: up to 150 MB/sec
 - Sustained write: up to 48 MB/sec
 - High-speed Type:
 - Sustained read: up to 305 MB/sec
 - Sustained write: up to 155 MB/sec
- **Flash Management**
 - Built-in hardware ECC, enabling up to 40-bit correction per 1K bytes
 - Static/dynamic wear-leveling
 - Flash bad-block management
 - S.M.A.R.T.
 - Power Failure Management
 - ATA Secure Erase
 - TRIM
- **NAND Flash Type: MLC**
- **Temperature ranges**
 - Operating: 0°C to 70°C (32 ~ 158°F)
 - Storage: -40°C to 100°C (-40° ~ 212°F)
- **Supply voltage**
 - 5.0 V ± 5%
- **Power consumption (typical)***
 - Standard Type:
 - Active mode: 170 mA
 - Idle mode: 90 mA
 - High-speed Type:
 - Active mode: 265 mA
 - Idle mode: 95 mA
- **Connector type**
 - 7-pin SATA signal connector
 - Power segment options: 2 metal pins on each side of SATA connector or power cable connector
- **Form factor**
 - SATA Disk Module: 7-pin/180 degree
 - Dimensions (without housing):
 - 30.00x27.80x8.20, unit: mm**
 - 30.00x27.80x7.40, unit: mm***
 - Dimensions (with housing):
 - 32.50x29.40x8.53, unit: mm
- **Shock & Vibration******
 - Shock:1500 G
 - Vibration: 15 G
- **MTBF: >1,000,000 hours**
- **RoHS Recast compliant**
 - Complies with 2011/65/EU standard

*Varies from capacities. The values for performances and power consumptions presented are typical and may vary depending on flash configurations or platform settings. The term idle refers to the standby state of the device.

**Standard type

***High-speed type

****Non-operating

Table of Contents

| | |
|---|-----------|
| 1. GENERAL DESCRIPTIONS..... | 3 |
| 2. PIN ASSIGNMENTS | 3 |
| 3. PRODUCT SPECIFICATIONS..... | 5 |
| 3.1 CAPACITY..... | 5 |
| 3.2 PERFORMANCE | 5 |
| 3.3 ENVIRONMENTAL SPECIFICATIONS..... | 6 |
| 3.4 MEAN TIME BETWEEN FAILURES (MTBF)..... | 6 |
| 3.5 CERTIFICATION AND COMPLIANCE..... | 6 |
| 4. FLASH MANAGEMENT..... | 7 |
| 4.1 ERROR CORRECTION/DETECTION | 7 |
| 4.2 BAD BLOCK MANAGEMENT | 7 |
| 4.3 WEAR LEVELING | 7 |
| 4.4 POWER FAILURE MANAGEMENT..... | 7 |
| 4.5 ATA SECURE ERASE | 7 |
| 4.6 TRIM..... | 8 |
| 4.7 SATA POWER MANAGEMENT | 8 |
| 5. SOFTWARE INTERFACE..... | 9 |
| 5.1 COMMAND SET..... | 9 |
| 5.2 S.M.A.R.T..... | 9 |
| 6. ELECTRICAL SPECIFICATION | 11 |
| 7. PHYSICAL CHARACTERISTICS..... | 12 |
| 7.1 STANDARD..... | 12 |
| 7.1.1 W/O Housing | 12 |
| 7.1.2 With Housing..... | 13 |
| 7.2 HIGH-SPEED | 14 |
| 7.2.1 W/O Housing | 14 |
| 7.2.2 W/Housing | 15 |
| 8. PRODUCT ORDERING INFORMATION..... | 16 |
| 8.1 PRODUCT CODE DESIGNATIONS..... | 16 |
| 8.2 VALID COMBINATIONS | 17 |

1. General Descriptions

Apacer's SDM5-M (SATA Disk Module 5-M) is our next generation disk-on-module (DOM) series that offers elevated speed boost and higher error correction capabilities. Built with SATA 6 Gb/s interface, SDM5-M delivers exceptional performance in data transfer.

With its SATA interface compliance and compact size, this high-speed disk module defines an ideal balance of performance, capacities, reliability and cost. SDM5-M comes in moderate capacities that are suitable to boot industrial applications and light operating systems for specific operations, while with some extra memory space for data storage. The architectural nature of SATA disk module provides higher resistance to external environmental influences and better flexibility for motherboard space.

Regarding data reliability, SDM5-M is built in with powerful ECC engine that can correct up to 40-bit per 1KB data. In addition, the controller unit of this DOM device supports wear-leveling, SMART and power failure management for data integrity. With its trustable reliability, performance and cost effectiveness, Apacer's SDM5-M is definitely the ideal storage or cache solution for embedded and industrial computers, servers and thin clients.

2. Pin Assignments

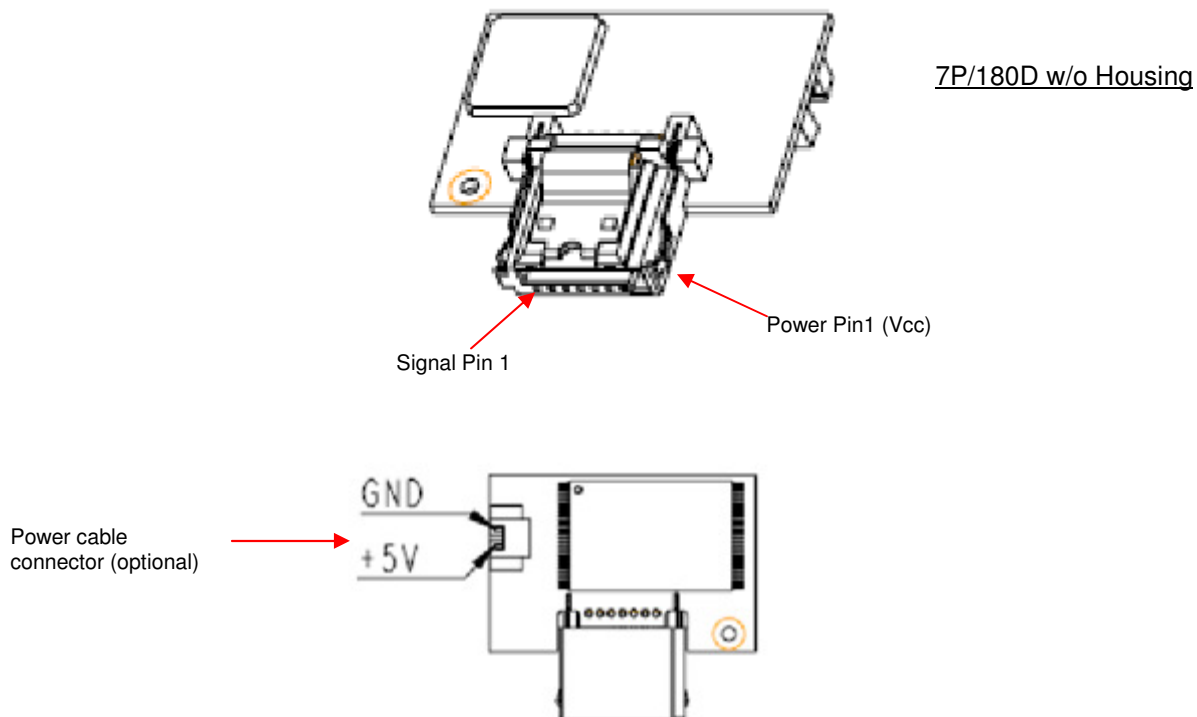

SATA-Disk Module 5 APSDMxxxxX3AX-ATMX

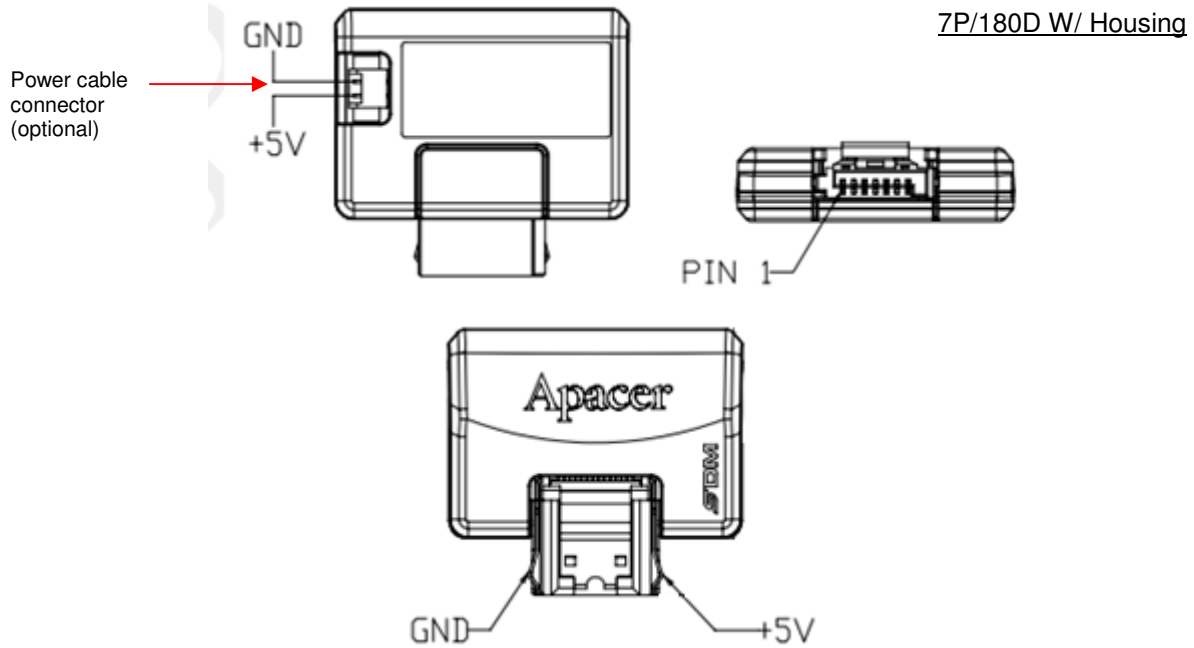

Table 1-3: Signal segment

| Pin | Type | Description |
|-----|------|--------------------------------|
| S1 | GND | |
| S2 | RxP | + Differential Receive Signal |
| S3 | RxN | - Differential Receive Signal |
| S4 | GND | |
| S5 | TxN | - Differential Transmit Signal |
| S6 | TxP | + Differential Transmit Signal |
| S7 | GND | |

Table 1-4: Power segment

| Pin | Signal/Description |
|-----|--------------------|
| P1 | VCC (5V) |
| P2 | GND |

3. Product Specifications

3.1 Capacity

Capacity specification of SDM5-M is available as shown in Table 3-1. It lists the specific capacity and the default numbers of heads, sectors and cylinders for each product line.

Table 3-1: Capacity specifications

| Capacity | Total bytes* | Cylinders | Heads | Sectors | Max LBA |
|----------|----------------|-----------|-------|---------|-------------|
| 8 GB | 8,012,390,400 | 15,525 | 16 | 63 | 15,649,200 |
| 16 GB | 16,013,942,784 | 16,383 | 16 | 63 | 31,277,232 |
| 32 GB | 32,017,047,552 | 16,383 | 16 | 63 | 62,533,296 |
| 64 GB | 64,023,257,088 | 16,383 | 16 | 63 | 125,045,424 |

*Display of total bytes varies from file systems, which means not all of the bytes can be used for storage.

**Notes: 1 GB = 1,000,000,000 bytes; 1 sector = 512 bytes.

LBA count addressed in the table above indicates total user storage capacity and will remain the same throughout the lifespan of the device. However, the total usable capacity of the SSD is most likely to be less than the total physical capacity because a small portion of the capacity is reserved for device maintenance usages.

3.2 Performance

Performances of SDM5-M are listed below in table 3-2.

Table 3-2: Performance (standard)

| Capacity | 8 GB | 16 GB | 32 GB |
|-------------------------------|------|-------|-------|
| Performance | | | |
| Sustained read (MB/s) | 100 | 150 | 150 |
| Sustained write (MB/s) | 12 | 22 | 48 |

Table 3-3: Performance (High-speed)

| Capacity | 16 GB | 32 GB | 64 GB |
|-------------------------------|-------|-------|-------|
| Performance | | | |
| Sustained read (MB/s) | 245 | 250 | 305 |
| Sustained write (MB/s) | 40 | 85 | 155 |

Note: Results may differ from various flash configurations or host system setting

3.3 Environmental Specifications

Environmental specification of SDM5-M product follows MIL-STD-810 standards as shown in Table 3-4.

Table 3-4 SDM5-M environmental specifications

| Item | Specification |
|-------------------------|---|
| Operating temp. | 0~70°C |
| Non-operating temp. | -40~100(°C) |
| Operating vibration | 20~2000(Hz), 7.69 (Grms), random wave, X, Y, Z axis |
| Non-operating vibration | 10~2000(Hz), 15(G), sine wave, X, Y, Z axis |
| Operating shock | 50(G), 11(ms), half-sine wave |
| Non-operating shock | 1500(G), 0.5(ms), half-sine wave |

3.4 Mean Time Between Failures (MTBF)

Mean Time Between Failures (MTBF) is predicted based on reliability data for the individual components in SDM5-M. The prediction result for SDM5-M is more than 1,000,000 hours.

Notes about the MTBF:

The MTBF is predicated and calculated based on “Telcordia Technologies Special Report, SR-332, Issue 2” method.

3.5 Certification and Compliance

SDM5-M complies with the following standards:

- CE
- FCC
- RoHS Recast
- MIL-STD-810

4. Flash Management

4.1 Error Correction/Detection

SDM5-M implements a hardware ECC scheme, based on the BCH algorithm. It can detect and correct up to 40-bit error in 1K bytes.

4.2 Bad Block Management

Current production technology is unable to guarantee total reliability of NAND flash memory array. When a flash memory device leaves factory, it comes with a minimal number of initial bad blocks during production or out-of-factory as there is no currently known technology that produce flash chips free of bad blocks. In addition, bad blocks may develop during program/erase cycles. When host performs program/erase command on a block, bad block may appear in Status Register. Since bad blocks are inevitable, the solution is to keep them in control. Apacer flash devices are programmed with ECC, block mapping technique and S.M.A.R.T to reduce invalidity or error. Once bad blocks are detected, data in those blocks will be transferred to free blocks and error will be corrected by designated algorithms.

4.3 Wear Leveling

Flash memory devices differ from Hard Disk Drives (HDDs) in terms of how blocks are utilized. For HDDs, when a change is made to stored data, like erase or update, the controller mechanism on HDDs will perform overwrites on blocks. Unlike HDDs, flash blocks cannot be overwritten and each P/E cycle wears down the lifespan of blocks gradually. Repeatedly program/erase cycles performed on the same memory cells will eventually cause some blocks to age faster than others. This would bring flash storages to their end of service term sooner. Wear leveling is an important mechanism that level out the wearing of blocks so that the wearing-down of blocks can be almost evenly distributed. This will increase the lifespan of SSDs. Commonly used wear leveling types are Static and Dynamic.

4.4 Power Failure Management

Power Failure Management plays a crucial role when experiencing unstable power supply. Power disruption may occur when users are storing data into the SSD. In this urgent situation, the controller would run multiple write-to-flash cycles to store the metadata for later block rebuilding. This urgent operation requires about several milliseconds to get it done. At the next power up, the firmware will perform a status tracking to retrieve the mapping table and resume previously programmed NAND blocks to check if there is any incompleteness of transmission.

4.5 ATA Secure Erase

ATA Secure Erase is an ATA disk purging command currently embedded in most of the storage drives. Defined in ATA specifications, (ATA) Secure Erase is part of Security Feature Set that allows storage drives to erase all user data areas. The erase process usually runs on the firmware level as most of the ATA-based storage media currently in the market are built-in with this command. ATA Secure Erase can securely wipe out the user data in the drive and protects it from malicious attack.

4.6 TRIM

TRIM, though in capital letters usually, is a memory computation command rather than an abbreviation. It is mainly a SATA command that enables the operating system to inform the SSD (Solid State Drive) which blocks of previously stored data are no longer valid, due to erases by the host or operating system, such as file deletions or disk formatting. Once notified, SSD will begin the discard of the invalid LBAs and retain more space for itself, in fact, the discarded is no longer recoverable.

When an LBA is replaced by the operating system, as with overwrite of a file, the SSD is informed that the originally occupied LBA is determined as no longer in use or invalid. The SSD will not save those blocks in garbage collected sectors. Noticeably, a file deletion command by host or operating system never actually erases the actual content, rather, just the file is marked as deleted. This issue is even specifically noticeable for flash based memory devices, such as SSDs. In fact, an SSD will keep garbage collecting the invalid, previously occupied LBAs, if it is not informed that these LBAs can be erased. Thus, the SSD would experience a significant performance downfall.

4.7 SATA Power Management

By complying with SATA 6.0 Gb/s specifications, the SSD supports the following SATA power saving modes:

- ACTIVE: PHY ready, full power, Tx & Rx operational
- PARTIAL: Reduces power, resumes in under 10 μ s (microseconds)
- SLUMBER: Reduces power, resumes in under 10 ms (milliseconds)
- HIPM: Host-Initiated Power Management
- DIPM: Device-Initiated Power Management
- AUTO-SLUMBER: Automatic transition from partial to slumber.

Note: the behaviors of power management features would depend on host/device settings.

5. Software Interface

5.1 Command Set

Table 5-1: Command set

| Code | Command | Code | Command |
|------|------------------------------|------|------------------------|
| E5h | Check Power Mode | F3h | Security Erase Prepare |
| 06h | Data Set Management | F4h | Security Erase Unit |
| 90h | Execute Device Diagnostic | F5h | Security Freeze Lock |
| E7h | Flush Cache | F1h | Security Set Password |
| EAh | Flush Cache EXT | F2h | Security Unlock |
| Ech | Identify Device | 70h | Seek |
| E3h | Idle | Efh | Set Features |
| E1h | Idle Immediate | C6h | Set Multiple Mode |
| 91h | Initialize Device Parameters | E6h | Sleep |
| C8h | Read DMA | B0h | SMART |
| 25h | Read DMA EXT | E2h | Standby |
| C4h | Read Multiple | E0h | Standby Immediate |
| 29h | Read Multiple EXT | Cah | Write DMA |
| 20h | Read Sector | 35h | Write DMA EXT |
| 24h | Read Sector EXT | C5h | Write Multiple |
| 40h | Read Verify Sectors | 39h | Write Multiple EXT |
| 42h | Read Verify Sectors EXT | 30h | Write Sector |
| 10h | Recalibrate | 34h | Write Sector EXT |
| F6h | Security Disable Password | | |

5.2 S.M.A.R.T.

S.M.A.R.T. is an abbreviation for Self-Monitoring, Analysis and Reporting Technology, a self-monitoring system that provides indicators of drive health as well as potential disk problems. It serves as a warning for users from unscheduled downtime by monitoring and displaying critical drive information. Ideally, this should allow taking proactive actions to prevent drive failure and make use of S.M.A.R.T. information for future product development reference.

Apacer devices use the standard SMART command B0h to read data out from the drive to activate our S.M.A.R.T. feature that complies with the ATA/ATAPI specifications. S.M.A.R.T. Attribute IDs shall include initial bad block count, total later bad block count, maximum erase count, average erase count, power on hours and power cycle. When the S.M.A.R.T. Utility running on the host, it analyzes and reports the disk status to the host before the device reaches in critical condition.

SATA-Disk Module 5 APSDMxxxxX3AX-ATMX

Note: attribute IDs may vary from product models due to various solution design and supporting capabilities.

Apacer memory products come with S.M.A.R.T. commands and subcommands for users to obtain information of drive status and to predict potential drive failures. Users can take advantage of the following commands/subcommands to monitor the health of the drive.

| Code | SMART Subcommand |
|------|-----------------------------------|
| D0h | READ DATA |
| D1h | READ ATTRIBUTE THRESHOLDS |
| D2h | Enable/Disable Attribute Autosave |
| D4h | Execute Off-line Immediate |
| D5h | Read Log (optional) |
| D6h | Write Log (optional) |
| D8h | Enable Operations |
| D9h | Disable operations |
| DAh | Return Status |

General SMART attribute structure

| Byte | Description |
|-------|-------------|
| 0 | ID (Hex) |
| 1 – 2 | Status flag |
| 3 | Value |
| 4 | Worst |
| 5*-11 | Raw Data |

*Byte 5: LSB

SMART attribute ID list

| ID (Hex) | Attribute Name | Note |
|------------|-----------------------------|----------------------|
| 9 (0x09) | Power-on hours | General |
| 12 (0x0C) | Power cycle count | General |
| 163 (0xA3) | Max. erase count | General |
| 164 (0xA4) | Avg. erase count | General |
| 166 (0xA6) | Total later bad block count | General |
| 167 (0xA7) | SSD Protect Mode | 0: R/W, 3: Read Only |
| 168 (0xA8) | SATA PHY Error Count | Command Fail Count |
| 175 (0xAF) | Bad Cluster Table Count | ECC Fail Count |
| 192 (0xC0) | Unexpected Power Loss Count | ATA Standby Command |
| 194 (0xC2) | Temperature | PCB Temperature |
| 241 (0xF1) | Total sectors of write | LBA |

6. Electrical Specification

Caution: Absolute Maximum Stress Ratings – Applied conditions greater than those listed under “Absolute Maximum Stress Ratings” may cause permanent damage to the device. This is a stress rating only and functional operation of the device at these conditions or conditions greater than those defined in the operational sections of this data sheet is not implied. Exposure to absolute maximum stress rating conditions may affect device reliability.

Table 6-1: Operating range

| Items | Range |
|---------------------|--------------------|
| Supply Voltage | 5V±5% (4.75-5.25V) |
| Ambient temperature | 0 °C to +70 °C |

Table 6-2: Typical power consumption (standard)

| Modes \ Capacity | 8 GB | 16 GB | 32 GB |
|------------------|--------------------|-------|-------|
| | Active (mA) | 120 | 135 |
| Idle (mA) | 85 | 85 | 90 |

Table 6-3: Typical power consumption (high-speed)

| Modes \ Capacity | 16 GB | 32 GB | 64 GB |
|------------------|--------------------|-------|-------|
| | Active (mA) | 170 | 220 |
| Idle (mA) | 85 | 90 | 95 |

Note: Results may differ from various flash configurations or host system setting

7. Physical Characteristics

7.1 Standard

7.1.1 W/O Housing

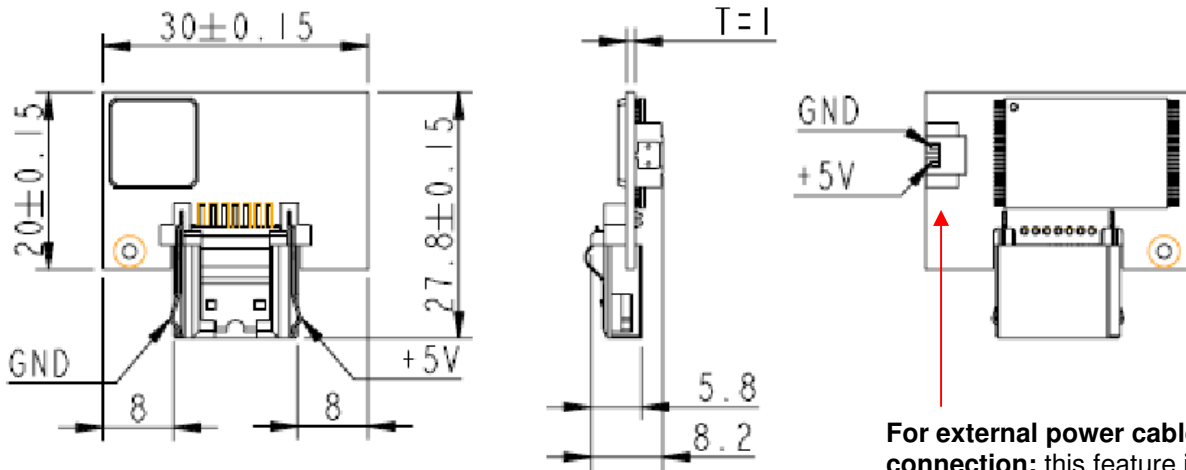

For external power cable connection: this feature is available as an option for Standard Type.

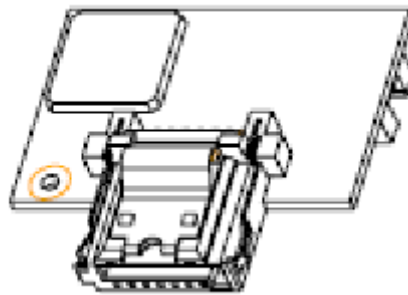

Unit: mm
Tolerance: ± 0.25

SATA-Disk Module 5 APSDMxxxxX3AX-ATMX

7.1.2 With Housing

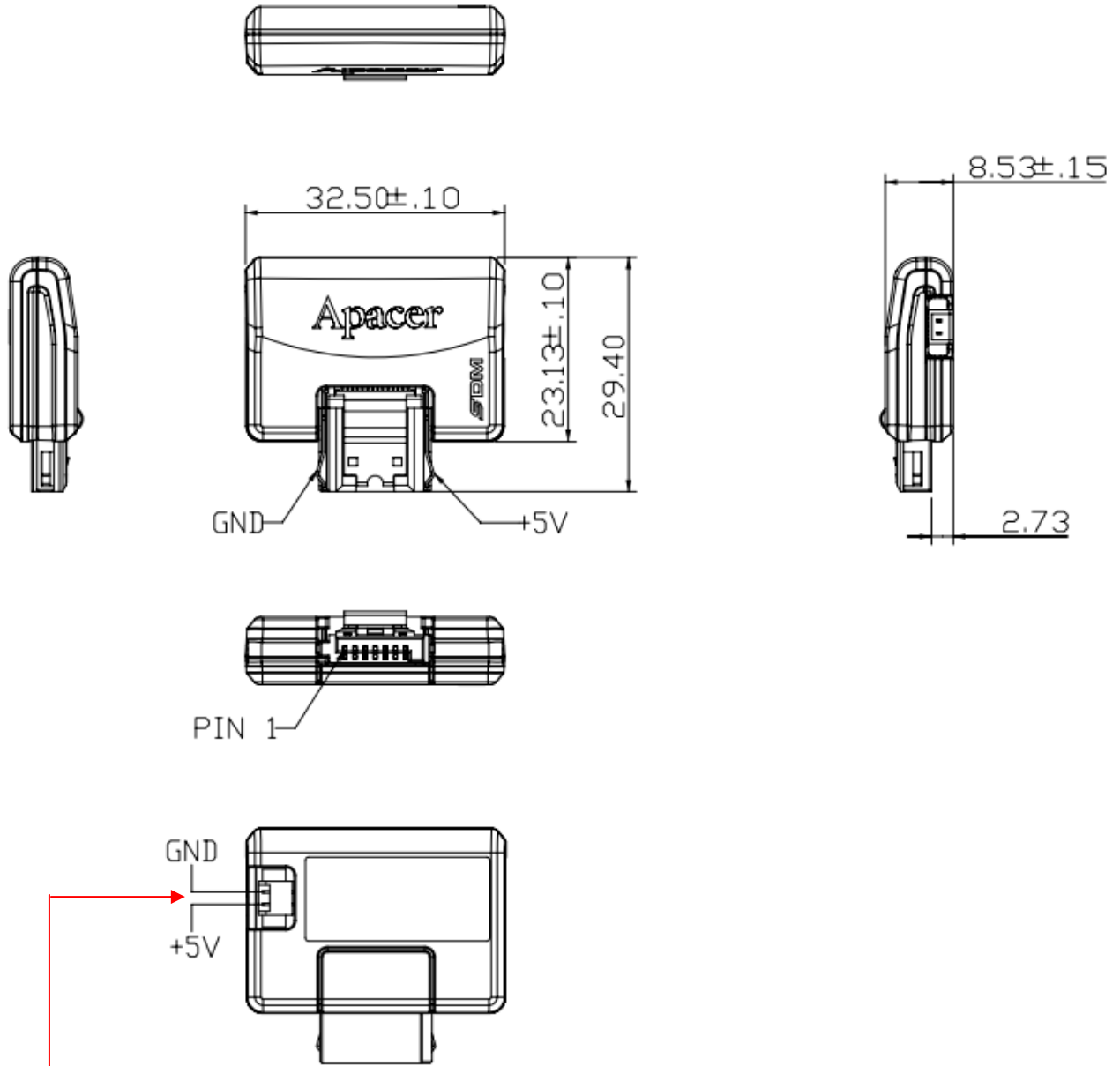

For external power cable connection: this feature is available as an option for Standard Type.

Unit: mm
Tolerance: ± 0.25

SATA-Disk Module 5 APSDMxxxxX3AX-ATMX

7.2 High-speed

Please be noted that High-speed type comes in only power cable-less form.

7.2.1 W/O Housing

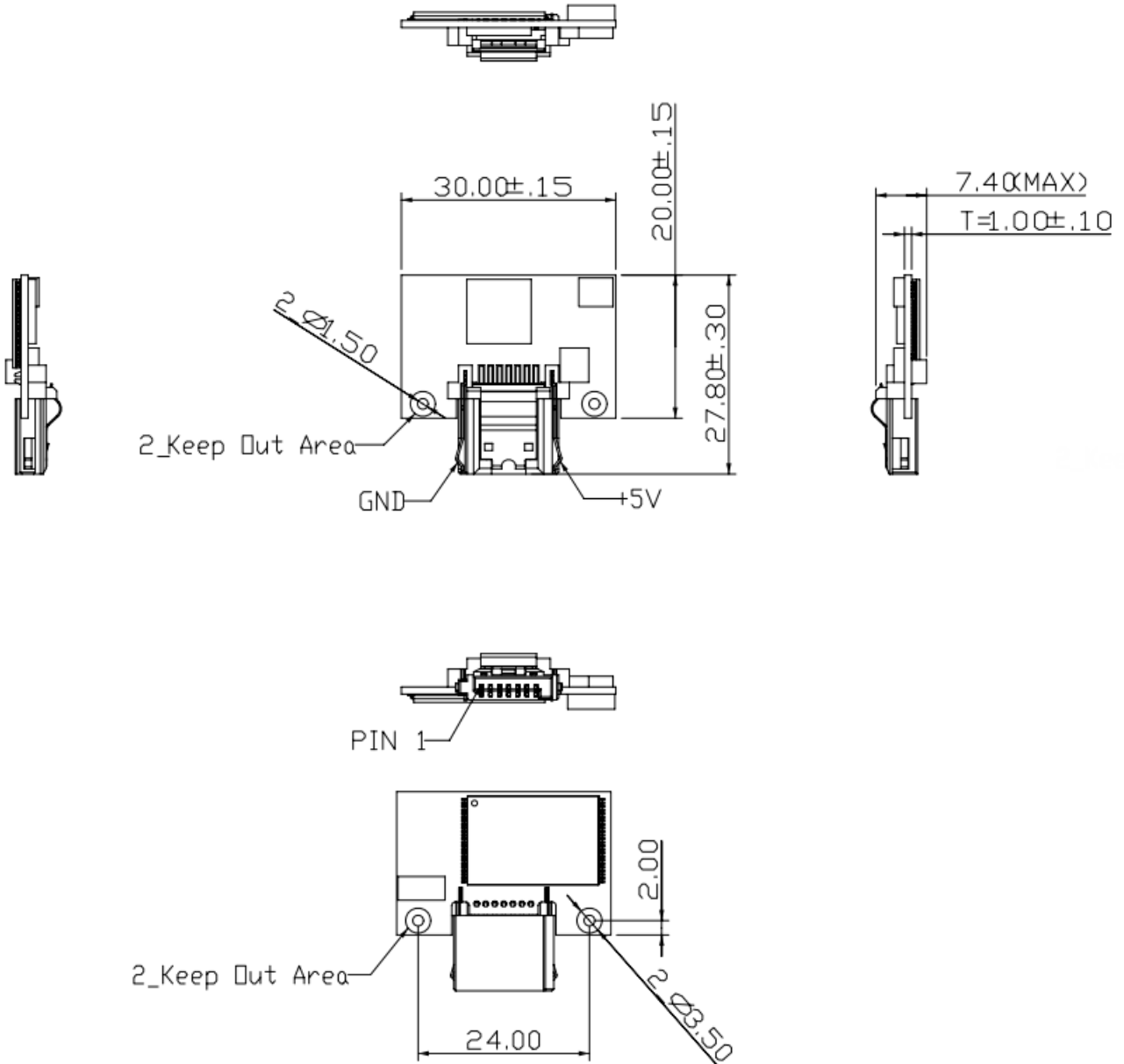

Unit: mm
Tolerance: ± 0.25

SATA-Disk Module 5 APSDMxxxxX3AX-ATMX

7.2.2 W/Housing

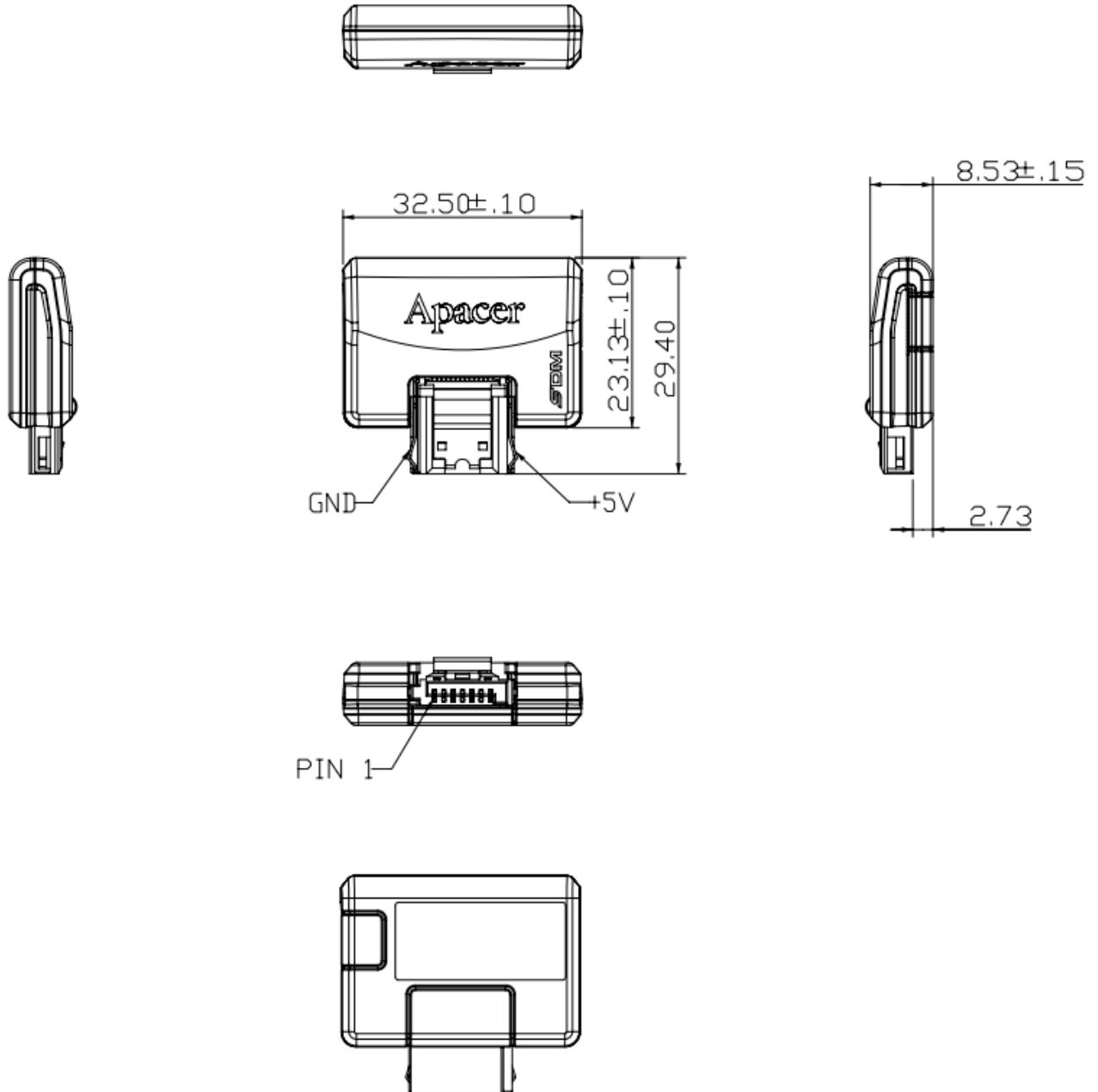

Unit: mm
Tolerance: ± 0.25

8. Product Ordering Information

8.1 Product Code Designations

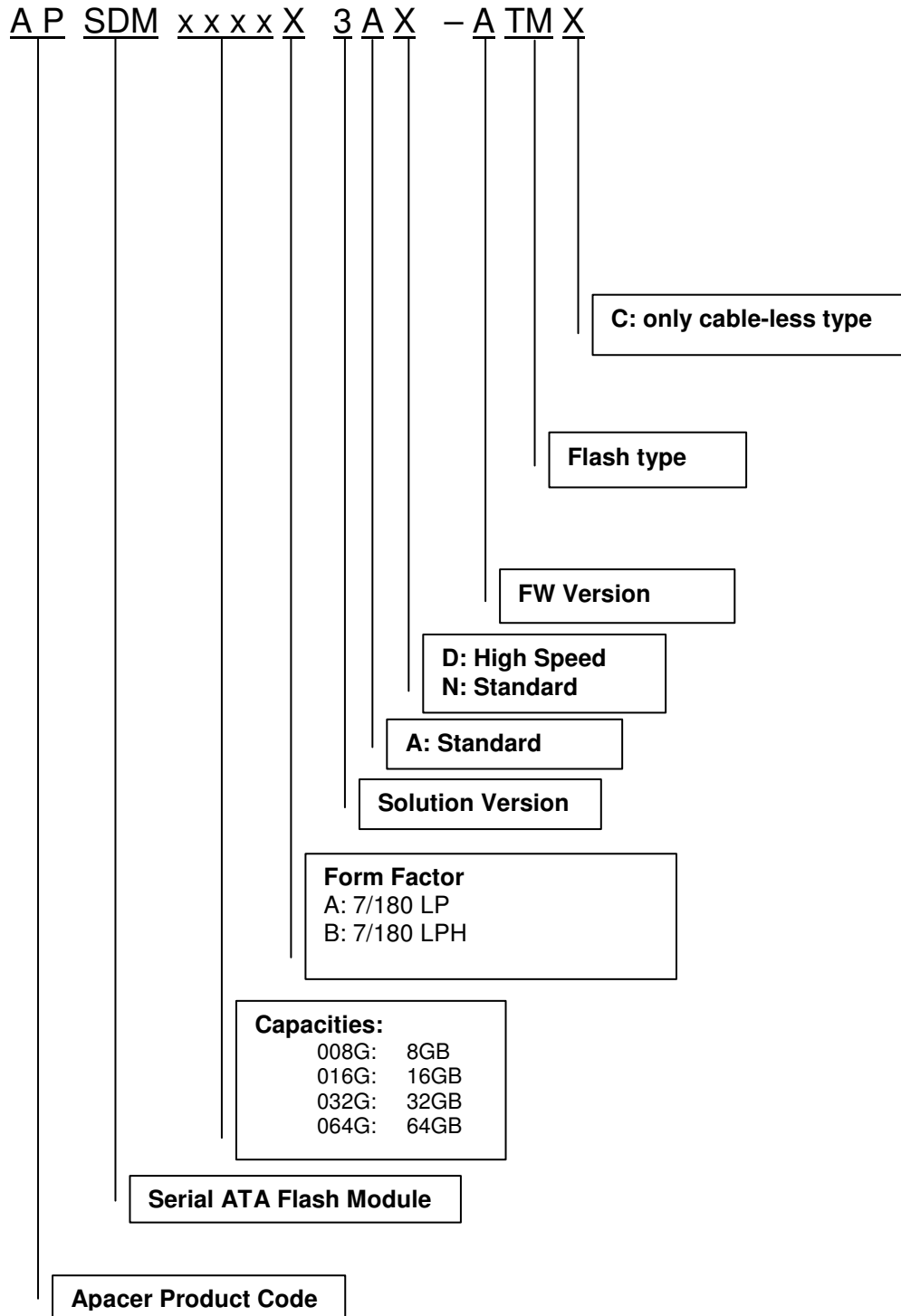

8.2 Valid Combinations

Standard (LP) 180D w/o Housing 7pin LP

| Capacity | Standard Temperature Models |
|-----------------|------------------------------------|
| 8GB | APSDM008GA3AN-ATM |
| 16GB | APSDM016GA3AN-ATM |
| 32GB | APSDM032GA3AN-ATM |

Standard (LPH) 180D with Housing 7pin LP

| Capacity | Standard Temperature Models |
|-----------------|------------------------------------|
| 8GB | APSDM008GB3AN-ATM |
| 16GB | APSDM016GB3AN-ATM |
| 32GB | APSDM032GB3AN-ATM |

Notes: The P/Ns are for models with power cable connector option. To purchase the products without power cable connector, there will be an additional digit "C" added at the last of the P/N. For instance, to purchase the 16GB model without power cable and housing, the P/N will appear as APSDM016GA3AN-ATMC".

High-Speed (LP) 180D w/o Housing 7pin LP (available in cable-less type only)

| Capacity | Standard Temperature Models |
|-----------------|------------------------------------|
| 16GB | APSDM016GA3AD-ATMC |
| 32GB | APSDM032GA3AD-ATMC |
| 64GB | APSDM064GA3AD-ATMC |

High-Speed (LPH) 180D with Housing 7pin LP (available in cable-less type only)

| Capacity | Standard Temperature Models |
|-----------------|------------------------------------|
| 16GB | APSDM016GB3AD-ATMC |
| 32GB | APSDM032GB3AD-ATMC |
| 64GB | APSDM064GB3AD-ATMC |

Note: Please consult with Apacer sales representatives for availability.

Revision History

| Revision | Date | Description | Remark |
|----------|------------|---|--------|
| 0.1 | 08/26/2013 | Preliminary release | |
| 0.2 | 08/27/2013 | Added housing type Added 32GB performance and power consumption results | |
| 1.0 | 10/17/2013 | Official release | |
| 1.1 | 11/13/2013 | Added extra notes for power cable-less type in Product Ordering Information | |
| 1.2 | 04/02/2014 | Updated 16GB performance and power consumption | |

Global Presence

| | |
|------------------------------|---|
| Taiwan (Headquarters) | Apacer Technology Inc. Apacer Technology Inc. 1F., No.32, Zhongcheng Rd., Tucheng Dist., New Taipei City 236, Taiwan R.O.C. Tel: 886-2-2267-8000 Fax: 886-2-2267-2261 amtsales@apacer.com |
| U.S.A. | Apacer Memory America, Inc. 386 Fairview Way, Suite102, Milpitas, CA 95035 Tel: 1-408-518-8699 Fax: 1-408-935-9611 sa@apacerus.com |
| Japan | Apacer Technology Corp. 5F, Matsura Bldg., Shiba, Minato-Ku Tokyo, 105-0014, Japan Tel: 81-3-5419-2668 Fax: 81-3-5419-0018 jpservices@apacer.com |
| Europe | Apacer Technology B.V. Science Park Eindhoven 5051 5692 EB Son, The Netherlands Tel: 31-40-267-0000 Fax: 31-40-267-0000#6199 sales@apacer.nl |
| China | Apacer Electronic (Shanghai) Co., Ltd 1301, No.251,Xiaomujiao Road, Shanghai, 200032, China Tel: 86-21-5529-0222 Fax: 86-21-5206-6939 sales@apacer.com.cn |
| India | Apacer Technologies Pvt Ltd, # 535, 1st Floor, 8th cross, JP Nagar 3rd Phase, Bangalore – 560078, India Tel: 91-80-4152-9061 sales_india@apacer.com |