

RoHS Compliant

SATA Disk Module

7P SDM Multi-PowerPath Power Cable-less solution Design Guide

Oct 31, 2017

Version 1.0



Apacer Technology Inc.

1F, No.32, Zhongcheng Rd., Tucheng Dist., New Taipei City, Taiwan, R.O.C

Tel: +886-2-2267-8000 Fax: +886-2-2267-2261

www.apacer.com

Table of Contents

1. GENERAL DESCRIPTION	3
2. MULTI-POWERPATH TECHNOLOGY	3
3. SDM7+2 - PIN ASSIGNMENTS	4
4. SDM7+2 - DEVICE & HOST ARRANGEMENT.....	5
5. SDM7+2 - PHYSICAL CHARACTERISTICS	8
6. SDM7+2 - REFERENCE CIRCUIT	10
7. SDM7+2 - REFERENCE BOM LIST	10
8. SDM7 - PIN ASSIGNMENTS	10
9. SDM7 - PHYSICAL CHARACTERISTICS	12
10. SDM7 - REFERENCE DESIGN	14
11. SDM7 - REFERENCE BOM LIST	14

1. General Description

Apacer's SATA-Disk Module (SDM) is a high-performance embedded storage module in SATA 6.0 Gbps interface, backward with SATA 1.5 and 3.0 Gbps interfaces. The SDM is ideal for computing systems with standard SATA 7-pin signal connector, such as desktops, thin clients, workstations, data centers and servers. Despite of the absence of 15-pin SATA power segment, the SDM voltage supply depend on the 2 power pins at both side of the SATA connector. This design guide will provide a brief instruction for the design of this handy SATA DOM (Disk-on-Module).

Applied Model

Apacer SATA Disk Module with 7+2 pin SATA connector (7-pin SATA connector and 2-pin power pins).
Apacer SATA Disk Module with 7 pin SATA connector.

Notice

Modules with power cable connector for external power source are not applicable on this customized socket.

2. Multi-PowerPath Technology

Apacer's patented Multi-PowerPath technology provides a three-option plug-and-play solution for power supply. In addition to using a conventional power cable, power can also be supplied through either Pin7 VCC or state-of-art 7+2 pin connector on the side with cable-less design, allowing an SSD to operate without external power supply, giving it the dual advantages of signal integrity and flexible configuration on the motherboard. With the exclusive, innovative power circuit mechanism, Multi-PowerPath protects miniature SSD from being damaged by overheating even when power is concurrently supplied via the three methods.

3. SDM7+2 - Pin Assignments

Device

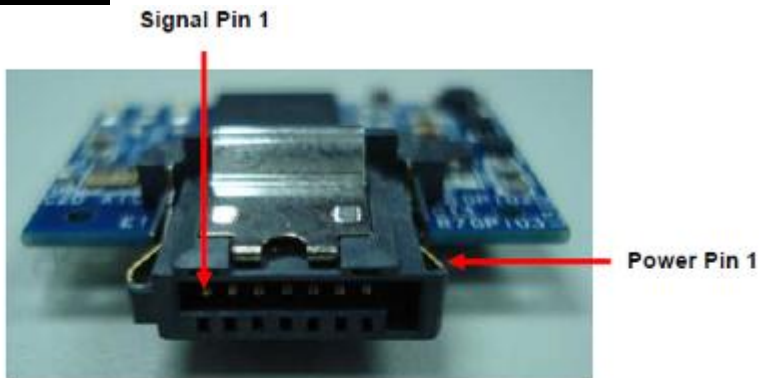

Signal Segment

Pin	Type	Description
1	GND	
2	Rx+	+ Differential Receive Signal
3	Rx-	- Differential Receive Signal
4	GND	
5	Tx-	- Differential Transmit Signal
6	Tx+	+ Differential Transmit Signal
7	GND	

Power Segment

Pin	Signal Description
P1	Vcc (5V)
P2	GND

Host

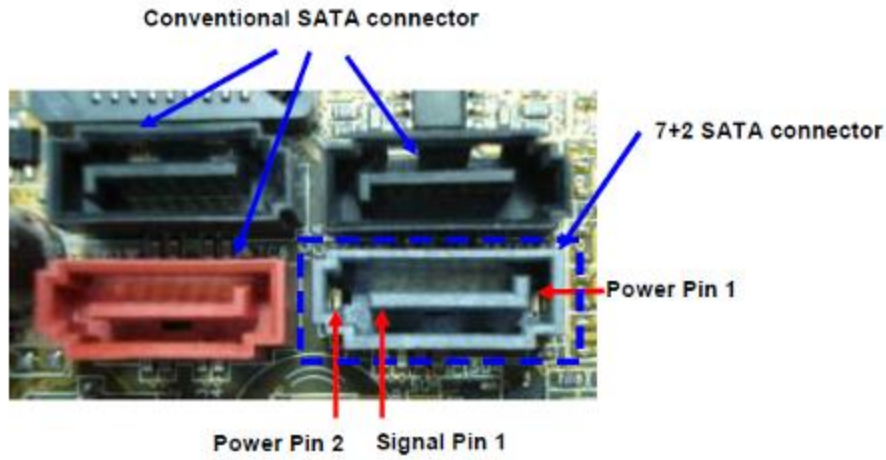

Signal Segment

Pin	Type	Description
1	GND	
2	Tx+	+ Differential Transmit Signal
3	Tx-	- Differential Transmit Signal
4	GND	
5	Rx-	- Differential Receive Signal
6	Rx+	+ Differential Receive Signal
7	GND	

Power Segment

Pin	Signal Description
P1	Vcc (5V)
P2	GND

The SATA Cable/Connector Diagram

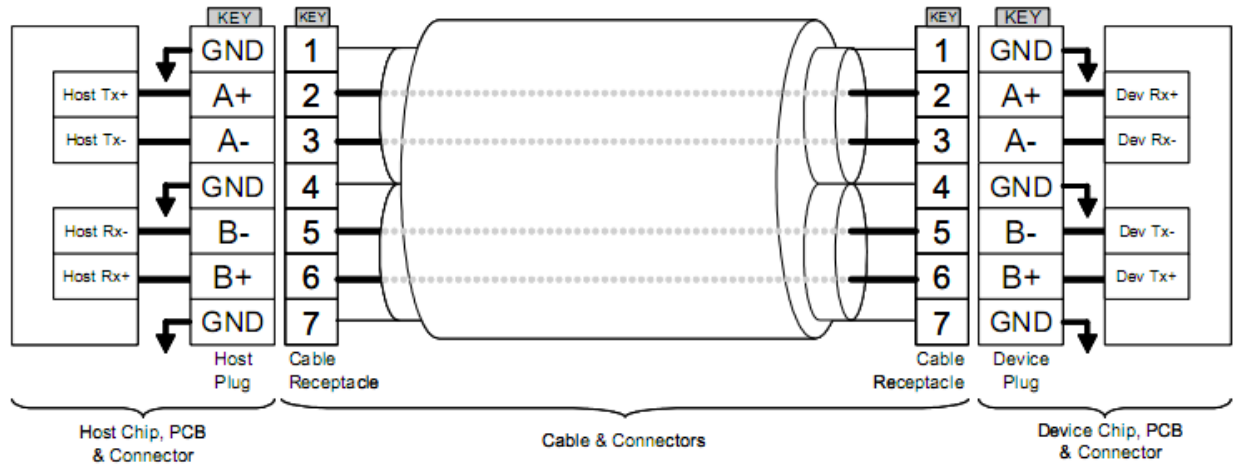

The connector on the left represents the Host with TX/RX differential pairs connected to a cable. The connector on the right shows the Device with TX/RX differential pairs also connected to the cable. Notice also the ground path connecting the shielding of the cable to the Cable Receptacle.

4. SDM7+2 - Device & Host Arrangement

Device

This connector type of SDM fits into any standard SATA male socket. There are two approaches according to the type of male SATA connector on the host side.

1. External power supply is required if plugged into the conventional male SATA.
2. External power supply is not required if plugged into the 7+2 male SATA connector.

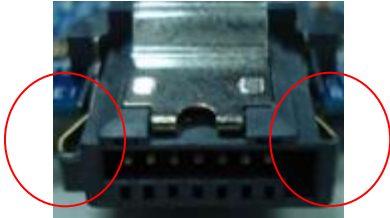

External power supply not required with the two additional metal pins (5V power and GND).



External power supply is required without the two additional metal pins.

Host

The 7+2 SATA male connector looks exactly the same as the conventional one. There are two approaches for designing the socket on the host.

1. External power supply is required if a conventional female SATA connector is used with the host, since there is no power pins.
2. No external power supply is required if a device with 7+2 female SATA connector is used with the host.

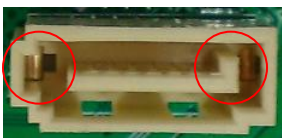

External power supply not required with the two additional metal pins (5V power and GND).



External power supply is required without the two additional metal pins.

Reminder

Modules with power cable connector for external power source are not applicable on this customized socket.

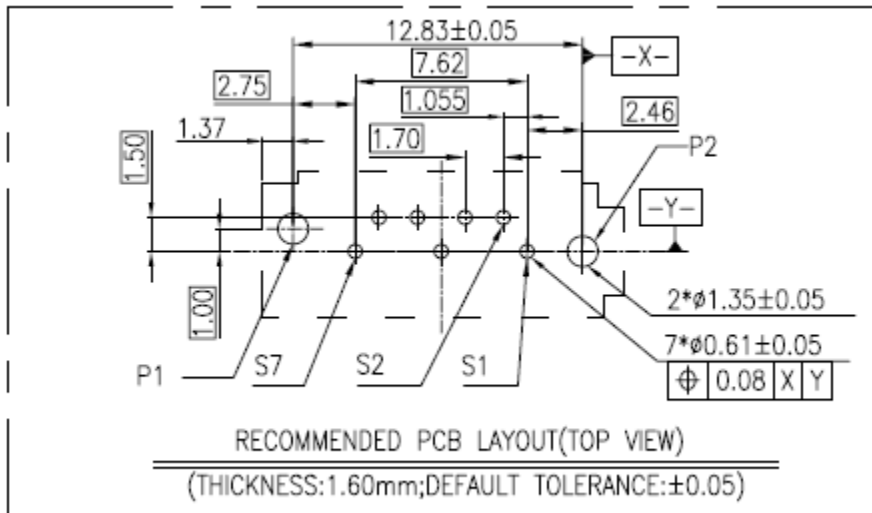
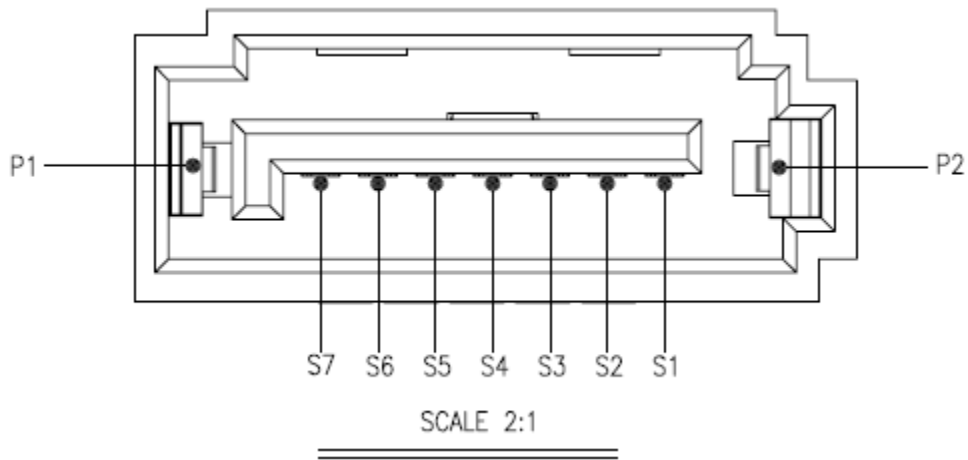

6. SDM7+2 - Reference Circuit

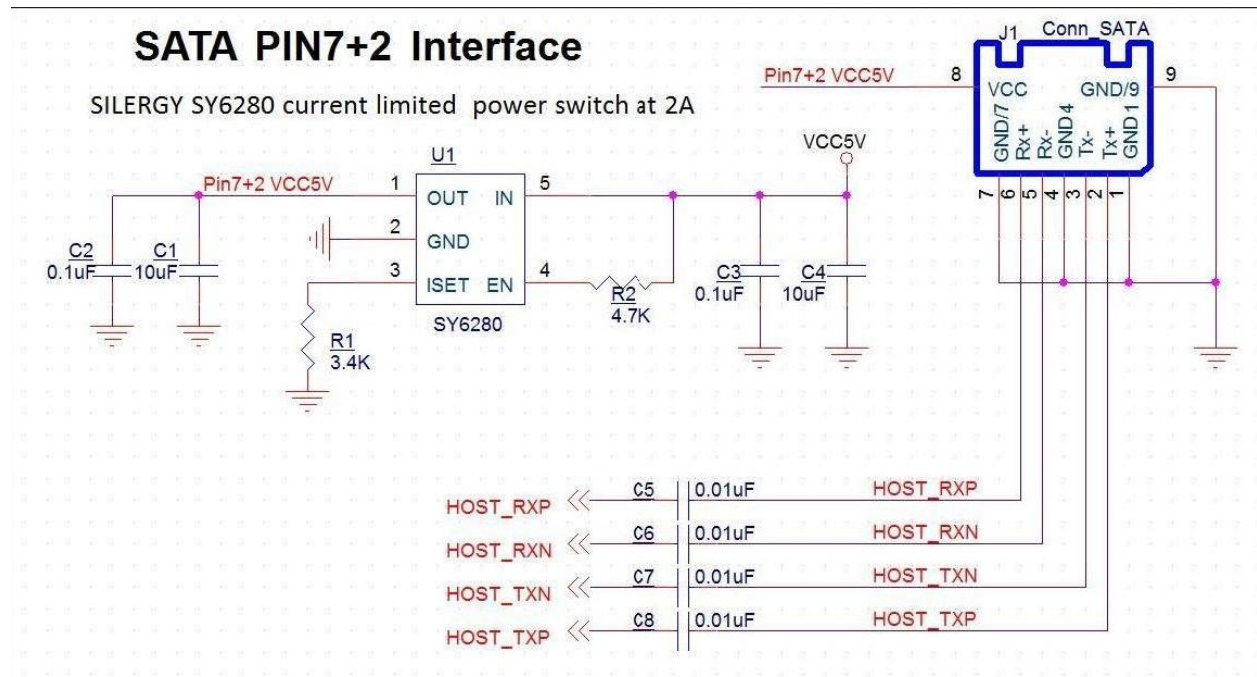

7. SDM7+2 - Reference BOM List

Item Number	Part Reference	Q'ty	Description
1	C1,C4	2	Cap 10uF
2	C2,C3	2	Cap 0.1uF
3	C5,C6,C7,C8	4	Cap 0.01uF
4	R1	1	3.4Kohm
5	R2	1	4.7Kohm
6	U1	1	Power Switch SY6280

8. SDM7 - Pin Assignments

Device

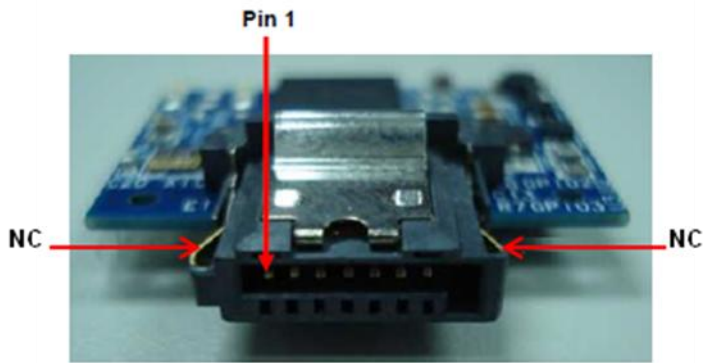

Pin define

Pin	Type	Description
1	GND	
2	Rx+	+ Differential Receive Signal
3	Rx-	- Differential Receive Signal
4	GND	
5	Tx-	- Differential Transmit Signal
6	Tx+	+ Differential Transmit Signal
7	Vcc	5V

The SATA Cable/Connector Diagram

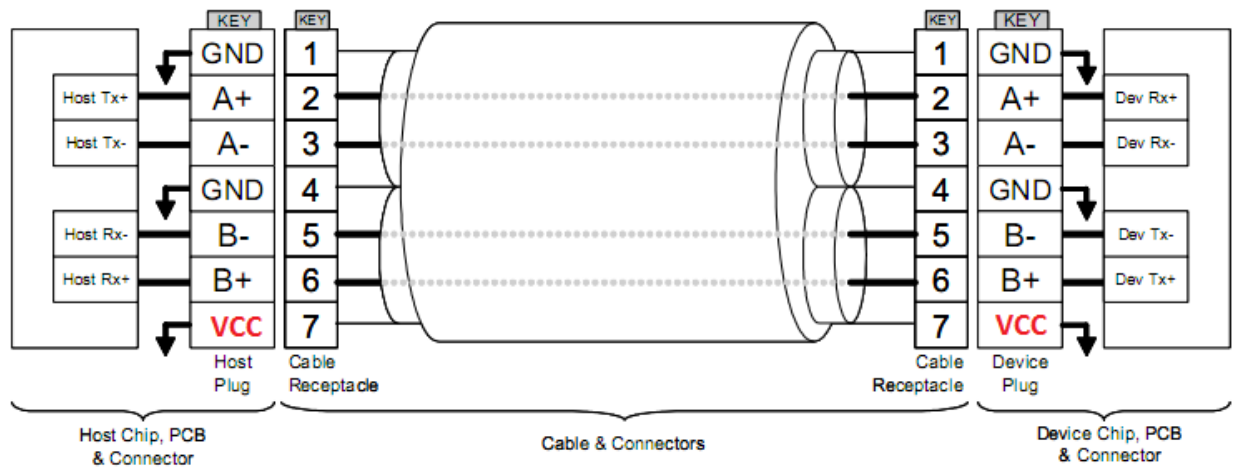

The connector on the left represents the Host with TX/RX differential pairs connected to a cable. The connector on the right shows the Device with TX/RX differential pairs also connected to the cable. Notice also the ground path connecting the shielding of the cable to the Cable Receptacle.

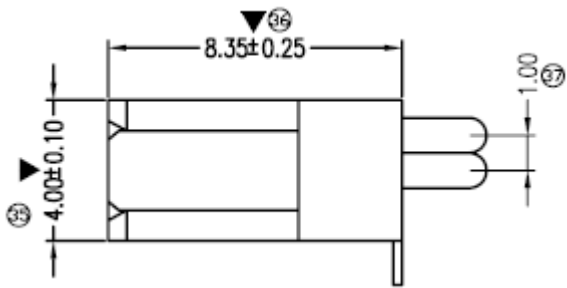
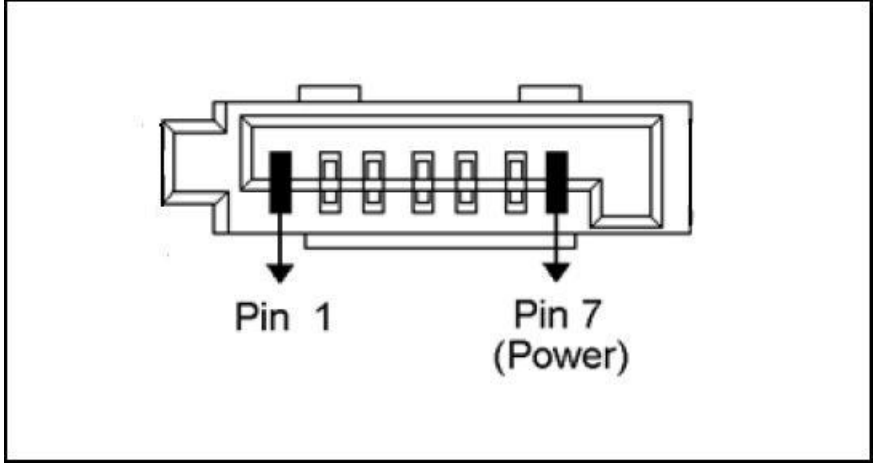

10. SDM7 - Reference Design

SATA PIN7 Interface

SILERGY SY6280 current limited power switch at 2A

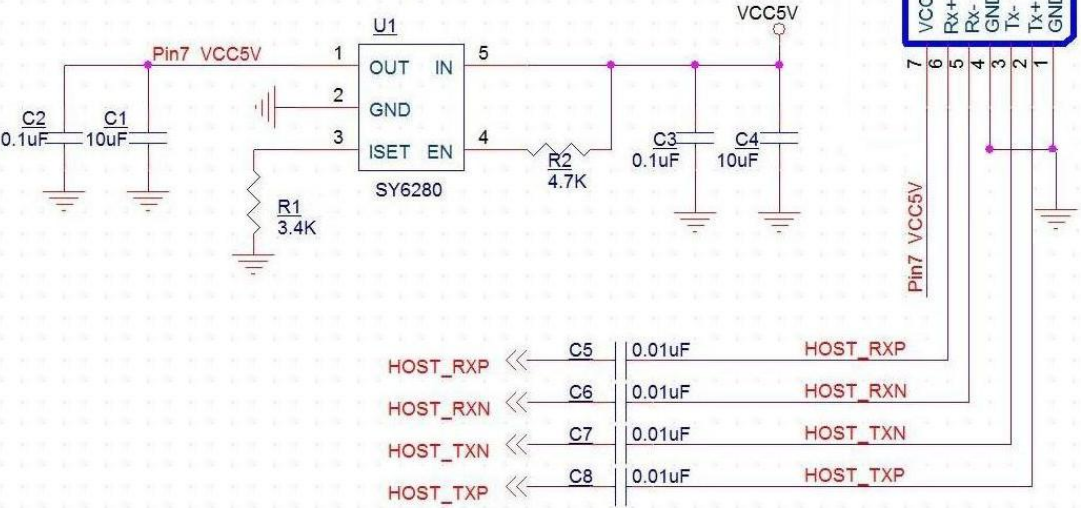

11. SDM7 - Reference BOM List

Item Number	Part Reference	Q'ty	Description
1	C1,C4	2	Cap 10uF
2	C2,C3	2	Cap 0.1uF
3	C5,C6,C7,C8	4	Cap 0.01uF
4	R1	1	3.4Kohm
5	R2	1	4.7Kohm
6	U1	1	Power Switch SY6280

Revision History

Revision	Date	Description	Remark
0.1	03/29/2017	Preliminary release	
1.0	10/31/2017	Official release Add Multi-PowerPath technology description	

Global Presence

Taiwan (Headquarters)	Apacer Technology Inc. Apacer Technology Inc. 1F., No.32, Zhongcheng Rd., Tucheng Dist., New Taipei City 236, Taiwan R.O.C. Tel: 886-2-2267-8000 Fax: 886-2-2267-2261 amtsales@apacer.com
U.S.A.	Apacer Memory America, Inc. 386 Fairview Way, Suite102, Milpitas, CA 95035 Tel: 1-408-518-8699 Fax: 1-408-935-9611 sa@apacerus.com
Japan	Apacer Technology Corp. 5F, Matsura Bldg., Shiba, Minato-Ku Tokyo, 105-0014, Japan Tel: 81-3-5419-2668 Fax: 81-3-5419-0018 jpservices@apacer.com
Europe	Apacer Technology B.V. Science Park Eindhoven 5051 5692 EB Son, The Netherlands Tel: 31-40-267-0000 Fax: 31-40-267-0000#6199 sales@apacer.nl
China	Apacer Electronic (Shanghai) Co., Ltd 1301, No.251,Xiaomujiao Road, Shanghai, 200032, China Tel: 86-21-5529-0222 Fax: 86-21-5206-6939 sales@apacer.com.cn
India	Apacer Technologies Pvt Ltd, # 535, 1st Floor, 8th cross, JP Nagar 3rd Phase, Bangalore – 560078, India Tel: 91-80-4152-9061 sales_india@apacer.com