

RoHS Compliant

Serial ATA Flash Drive

mSATA H1 Product Specifications

June 30, 2016

Version 1.2



Apacer Technology Inc.

1F, No.32, Zhongcheng Rd., Tucheng Dist., New Taipei City, Taiwan, R.O.C

Tel: +886-2-2267-8000

Fax: +886-2-2267-2261

www.apacer.com

Features:

- **Compliance with SATA Revision 3.1**
 - SATA 6.0 Gbps interface
 - Backward compatible with SATA 1.5/3.0 Gbps interfaces
 - ATA command set
- **Capacity**
 - 1, 2, 4, 8, 16, 32, 64 GB
- **Performance***
 - Interface burst read/write: 600 MB/sec
 - Sustained read: up to 130 MB/sec
 - Sustained write: up to 110 MB/sec
- **Flash Management**
 - Built-in hardware ECC
 - Wear leveling
 - Bad block management
 - S.M.A.R.T.
 - Power failure management
 - TRIM
- **NAND Flash Type: SLC**
- **MTBF: >2,000,000 hours**
- **Temperature Range**
 - Operating:
 - Standard: 0°C to 70°C
 - Extended: -40°C to 85°C
 - Storage: -40°C to 100°C
- **Supply Voltage**
 - 3.3 V \pm 5%
- **Power consumption***
 - Active mode: 380 mA
 - Idle mode: 100 mA
- **Form Factor**
 - JEDEC MO-300
 - Dimensions (50.80 x 29.85 x 1.00, unit: mm)
- **Connector**
 - 52-pin mSATA signal connector
- **Write Protect Switch (optional)**
- **Thermal Sensor (optional)**
- **RoHS Compliant**

*Varies from capacities. The values addressed here are typical and may vary depending on host system settings.

Table of Contents

1. Product Description	3
1.1 Introduction	3
1.2 Capacity Specifications.....	3
1.3 Performance	3
1.4 Pin Assignments	4
2. Software Interface	5
2.1 Command Set	5
2.2 S.M.A.R.T.....	5
3. Flash Management	6
3.1 Error Correction/Detection.....	6
3.2 Bad Block Management.....	6
3.3 Wear Leveling	6
3.4 Power Failure Management.....	6
3.5 TRIM.....	6
3.6 Secure Erase.....	6
4. Environment Specifications	7
4.1 Environmental	7
4.2 Mean Time Between Failures (MTBF)	7
4.3 Certification and Compliance	7
5. Electrical Characteristics	8
5.1 Operating Voltage	8
5.2 Power Consumption	8
6. Mechanical Characteristics	9
6.1 Dimensions	9
7. Product Ordering Information	10
7.1 Product Code Designations	10
7.2 Valid Combinations.....	11

1. Product Description

1.1 Introduction

Apacer's mSATA H1 delivers all the advantages of flash disk technology with the Serial ATA 6.0 Gbps interface and is fully compliant with the standard mSATA form factor, known as JEDEC MO-300 standard. The module is designed to operate at optimal efficiency and reliability. Its performance can reach up to 130 MB/s read and up to 110 MB/s write. Meanwhile, the power consumption of the mSATA module is much lower than traditional hard drives.

1.2 Capacity Specifications

Table 1-1 Capacity Specifications

Capacity	Total Bytes	Cylinders	Heads	Sectors	Max LBA
1 GB	1,011,032,064	15,525	16	63	1,974,672
2 GB	2,011,226,112	15,525	16	63	3,928,176
4 GB	4,011,614,208	15,525	16	63	7,835,184
8 GB	8,012,390,400	15,525	16	63	15,649,200
16 GB	16,013,942,784	16,383	16	63	31,277,232
32 GB	32,017,047,552	16,383	16	63	62,533,296
64 GB	64,023,257,088	16,383	16	63	125,045,424

*Display of total bytes varies from file systems.

**Cylinders, heads or sectors are not applicable for these capacities. Only LBA addressing applies.

LBA count addressed in the table above indicates total user storage capacity and will remain the same throughout the lifespan of the device. However, the total usable capacity of the SSD is most likely to be less than the total physical capacity because a small portion of the capacity is reserved for device maintenance usages.

1.3 Performance

Performance of mSATA H1 is shown in Table 1-2.

Table 1-2 Performance Specifications

Capacity Performance	1 GB	2 GB	4 GB	8 GB	16 GB	32 GB	64 GB
Sustained Read (MB/s)	30	65	130	130	130	130	130
Sustained Write (MB/s)	20	40	75	85	95	100	100

Note: Performance varies from flash configurations or host system settings.

1.4 Pin Assignments

Pin assignment of the mSATA H1 is shown in Figure 1-1 and described in Table 1-3.

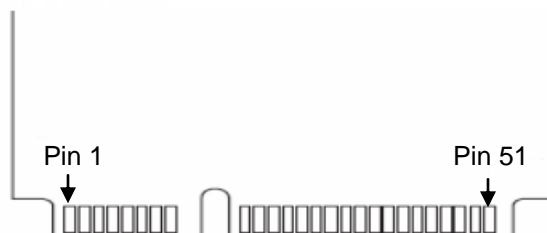

Figure 1-1 Pin Assignment

Table 1-3 Pin Assignment Description

Pin #	mSATA Pin	Description	Pin #	mSATA Pin	Description
1	NC	No Connect	27	SATA GND	SATA Ground Return Pin
2	+3.3V	3.3V Source	28	NC	No Connect
3	NC	No Connect	29	SATA GND	SATA Ground Return Pin
4	DGND	Digital GND	30	NC	No Connect
5	NC	No Connect	31	-A	Host Transmitter Differential Signal Pair
6	NC	No Connect	32	NC	No Connect
7	NC	No Connect	33	+A	Host Transmitter Differential Signal Pair
8	NC	No Connect	34	DGND	Digital GND
9	DGND	Digital GND	35	SATA GND	SATA Ground Return Pin
10	NC	No Connect	36	NC	No Connect
11	NC	No Connect	37	SATA GND	SATA Ground Return Pin
12	NC	No Connect	38	NC	No Connect
13	NC	No Connect	39	+3.3V	3.3V Source
14	NC	No Connect	40	DGND	Digital GND
15	DGND	Digital GND	41	+3.3V	3.3V Source
16	NC	No Connect	42	NC	No Connect
17	NC	No Connect	43	NC	No Connect
18	DGND	Digital GND	44	NC	No Connect
19	NC	No Connect	45	Vendor	Vendor specific
20	NC	No Connect	46	NC	No Connect
21	SATA GND	SATA Ground Return Pin	47	Vendor	Vendor specific
22	NC	No Connect	48	NC	No Connect
23	+B	Host Receiver Differential Signal Pair	49	DA/DSS	Device activity signal
24	+3.3V	3.3V Source	50	DGND	Digital GND
25	-B	Host Receiver Differential Signal Pair	51	GND	Default connect to GND
26	SATA GND	SATA Ground Return Pin	52	+3.3V	3.3V Source

2. Software Interface

2.1 Command Set

Table 2-1 summarizes the ATA commands supported by mSATA H1.

Table 2-1 Command Set

Code	Command	Code	Command
E5h	Check power mode	F6h	Security Disable Password
06h	Data Set management	F3h	Security Erase Prepare
B1H	DCO	F4h	Security Erase Unit
92h	Download Microcode PIO	F5h	Security Freeze Lock
93h	Download Microcode DMA	F1h	Security Set Password
90h	Execute drive diagnostic	F2h	Security Unlock
E7h	Flush cache	70h	Seek
EAh	Flush cache Ext	EFh	Set features
ECh	Identify device	F9h	Set Max Address
E3h	Idle	37h	Set Max Address Ext
E1h	Idle immediate	C6h	Set multiple mode
91h	Initialize drive parameters	E6h	Sleep
E4h	Read buffer	B0h	Smart
C9h	Read DMA (w/o retry)	E2h	Standby
C8h	Read DMA (w/retry)	E0h	Standby immediate
25h	Read DMA Ext	E8h	Write buffer
60h	Read FPDMA QUEUED	CBh	Write DMA (w/o retry)
2Fh	Read Log Ext	CAh	Write DMA (w/retry)
C4h	Read multiple	35h	Write DMA Ext
29h	Read multiple Ext	3Dh	Write DMA FUA Ext
F8h	Read native max address	61h	Write FPDMA QUEUED
27h	Read native max Ext	3Fh	Write Log Ext
21h	Read sector(s) (w/o retry)	C5h	Write multiple
20h	Read sector(s) (w/retry)	39h	Write multiple Ext
24h	Read sector(s) Ext	CEh	Write multiple FUA Ext
42h	Read Verify Ext	31h	Write sector(s) (w/o retry)
41h	Read verify sector(s) (w/o retry)	30h	Write sector(s) (w/retry)
40h	Read verify sector(s) (w/retry)	34h	Write sector(s) Ext
10h	Recalibrate	45h	Write uncorrectable

Note. Security command will only be workable when device runs in non-OPAL compliant mode.

2.2 S.M.A.R.T.

SMART, an acronym for Self-Monitoring, Analysis and Reporting Technology, is an open standard that allows a hard disk drive to automatically detect its health and report potential failures. When a failure is recorded by SMART, users can choose to replace the drive to prevent unexpected outage or data loss. Moreover, SMART can inform users of impending failures while there is still time to perform proactive actions, such as copy data to another device.

3. Flash Management

3.1 Error Correction/Detection

Flash memory cells will deteriorate with use, which might generate random bit errors in the stored data. Thus, this mSATA SSD module applies the BCH ECC Algorithm, which can detect and correct errors occur during Read process, ensure data been read correctly, as well as protect data from corruption. This device can correct up to 72bit/1K data.

3.2 Bad Block Management

Bad blocks are blocks that include one or more invalid bits, and their reliability is not guaranteed. Blocks that are identified and marked as bad by the manufacturer are referred to as “Initial Bad Blocks”. Bad blocks that are developed during the lifespan of the flash are named “Later Bad Blocks”. Apacer implements an efficient bad block management algorithm to detect the factory-produced bad blocks and manages any bad blocks that appear with use. This practice further prevents data being stored into bad blocks and improves the data reliability.

3.3 Wear Leveling

NAND Flash devices can only undergo a limited number of program/erase cycles, and in most cases, the flash media are not used evenly. If some areas get updated more frequently than others, the lifetime of the device would be reduced significantly. Thus, Wear Leveling technique is applied to extend the lifespan of NAND Flash by evenly distributing write and erase cycles across the media.

Apacer provides advanced Wear Leveling algorithm, which can efficiently spread out the flash usage through the whole flash media area. Moreover, by implementing both dynamic and static Wear Leveling algorithms, the life expectancy of the NAND Flash is greatly improved.

3.4 Power Failure Management

Power Failure Management plays a crucial role when experiencing unstable power supply. Power disruption may occur when users are storing data into the SSD. In this urgent situation, the controller would run multiple flush cycles to store the metadata for later block rebuilding. This urgent operation requires about several milliseconds to get it done. At the next power up, the firmware will perform a status tracking to retrieve the mapping table and resume previously programmed NAND blocks to check if there is any incompleteness of transmission.

3.5 TRIM

TRIM is a feature which helps improve the read/write performance and speed of solid-state drives (SSD). Unlike hard disk drives (HDD), SSDs are not able to overwrite existing data, so the available space gradually becomes smaller with each use. With the TRIM command, the operating system can inform the SSD which blocks of data are no longer in use and can be removed permanently. Thus, the SSD will perform the erase action, which prevents unused data from occupying blocks all the time.

3.6 Secure Erase

Secure Erase is a standard ATA command and will write all “0xFF” to fully wipe all the data on hard drives and SSDs. When this command is issued, the SSD controller will empty its storage blocks and return to its factory default settings.

Note. Secure erase command belongs to ATA security command.

4. Environment Specifications

4.1 Environmental

Table 4-1 Environmental Specifications

Environment	Specifications
Temperature	0°C to 70°C (Operating)
	-40°C to 85°C (Extended)
	-40°C to 100°C (in storage)
Shock	1,500G, 0.5ms
Vibration	20Hz~80Hz/1.52mm (frequency/displacement)
	80Hz~2000Hz/20G (frequency/displacement)
	X, Y, Z axis/60mins each
Drop	80cm free fall, 6 face of each
Bending	≥ 20N, hold 1min/5times
Torque	0.5N-m or 5deg, hold 5min/5times
ESD	Pass

Note: Shock and Vibration specifications are subject to change without notice.

4.2 Mean Time Between Failures (MTBF)

MTBF, an acronym for Mean Time Between Failures, is a measure of a device's reliability. Its value represents the average time between a repair and the next failure. The measure is typically in units of hours. The higher the MTBF value, the higher the reliability of the device. The predicted result of this mSATA device is higher than 2,000,000 hours.

4.3 Certification and Compliance

mSATA H1 complies with the following standards:

- SATA Revision 3.1
- RoHS
- ATA/ATAPI
- FCC
- CE
- BSMI
- MIL-STD-810G

5. Electrical Characteristics

5.1 Operating Voltage

Table 5-1 lists the supply voltage for mSATA H1.

Table 5-1 Operating Voltage

Parameter	Conditions
Supply Voltage	3.3V ± 5%

5.2 Power Consumption

Table 5-2 lists the power consumption for mSATA H1.

Table 5-2 Power Consumption (typical)

Mode \ Capacity	1 GB	2 GB	4 GB	8 GB	16 GB	32 GB	64 GB
Active (mA)	185	205	250	325	325	380	380
Idle (mA)	100	100	100	100	100	100	100

Note: Power consumptions may vary depending on host system settings.

6. Mechanical Characteristics

6.1 Dimensions

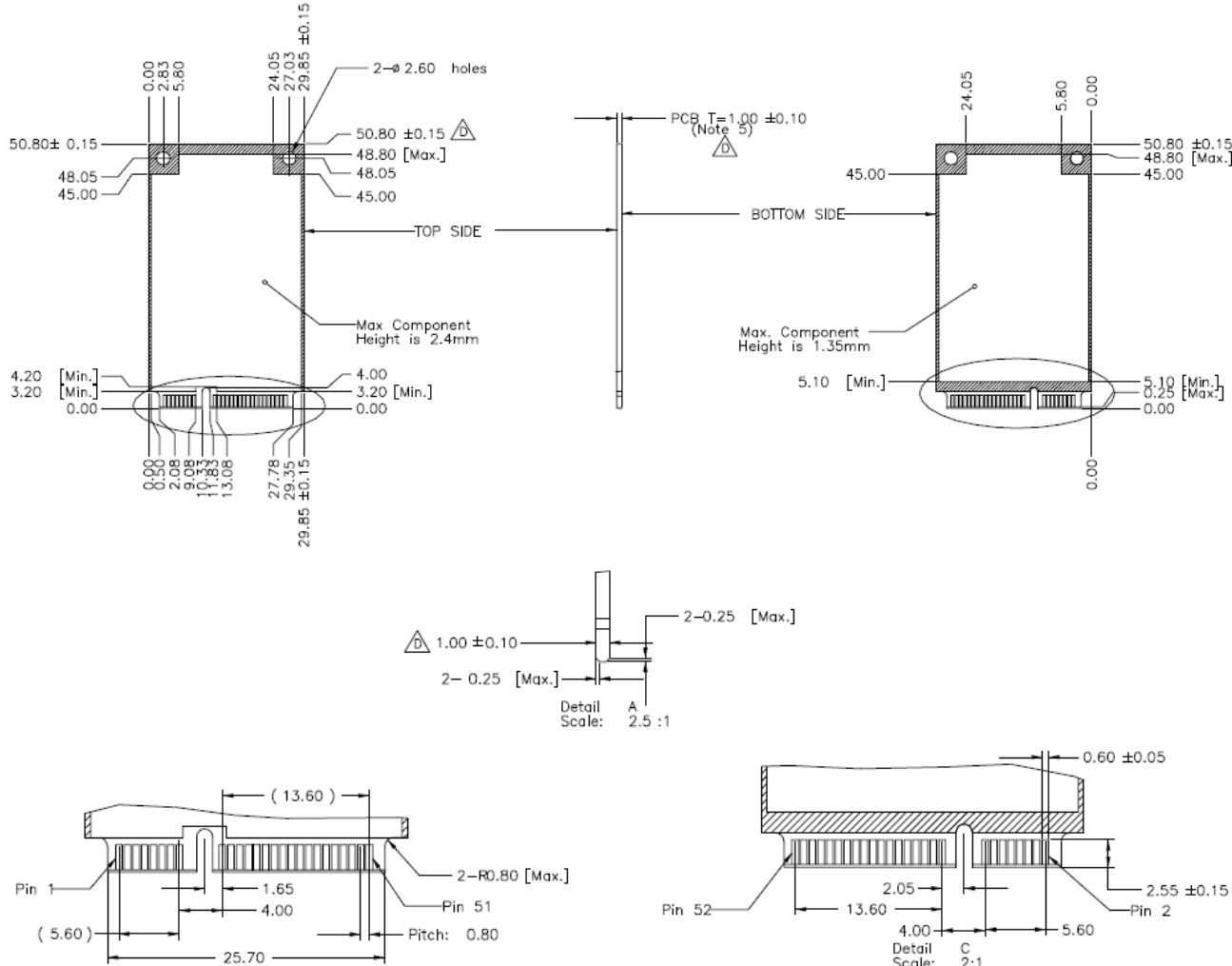

Unit: mm
 Tolerance: ± 0.2

7. Product Ordering Information

7.1 Product Code Designations

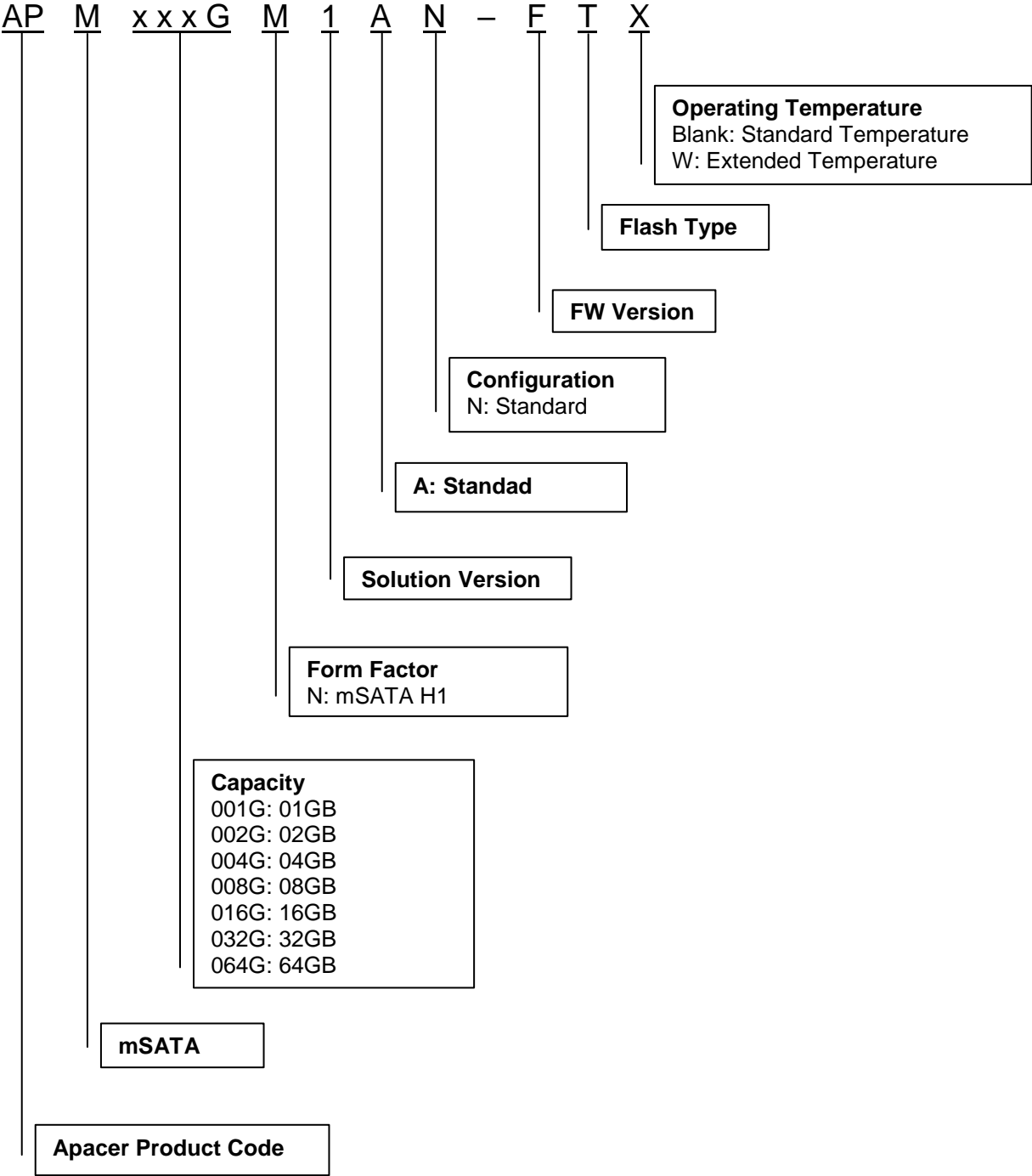

7.2 Valid Combinations

7.2.1 Standard Temperature (0°C to 70°C)

Capacity	Part Number
1GB	APM001GM1AN-FT
2GB	APM002GM1AN-FT
4GB	APM004GM1AN-FT
8GB	APM008GM1AN-FT
16GB	APM016GM1AN-FT
32GB	APM032GM1AN-FT
64GB	APM064GM1AN-FT

7.2.2 Extended Temperature (-40°C to 85°C)

Capacity	Part Number
1GB	APM001GM1AN-FTW
2GB	APM002GM1AN-FTW
4GB	APM004GM1AN-FTW
8GB	APM008GM1AN-FTW
16GB	APM016GM1AN-FTW
32GB	APM032GM1AN-FTW
64GB	APM064GM1AN-FTW

Note: Valid combinations are those products in mass production or will be in mass production. Consult your Apacer sales representative to confirm availability of valid combinations and to determine availability of new combinations.

Revision History

Revision	Description	Date
1.0	Official release	2/5/2016
1.1	Revised product ordering information	6/22/2016
1.2	Removed device sleep support	6/30/2016

Global Presence

Taiwan (Headquarters)	Apacer Technology Inc. 1F., No.32, Zhongcheng Rd., Tucheng Dist., New Taipei City 236, Taiwan R.O.C. Tel: 886-2-2267-8000 Fax: 886-2-2267-2261 amtsales@apacer.com
U.S.A.	Apacer Memory America, Inc. 46732 Lakeview Blvd., Fremont, CA 94538 Tel: 1-408-518-8699 Fax: 1-510-249-9551 sa@apacerus.com
Japan	Apacer Technology Corp. 5F, Matsura Bldg., Shiba, Minato-Ku Tokyo, 105-0014, Japan Tel: 81-3-5419-2668 Fax: 81-3-5419-0018 jpservices@apacer.com
Europe	Apacer Technology B.V. Science Park Eindhoven 5051 5692 EB Son, The Netherlands Tel: 31-40-267-0000 Fax: 31-40-267-0000#6199 sales@apacer.nl
China	Apacer Electronic (Shanghai) Co., Ltd Room D, 22/FL, No.2, Lane 600, JieyunPlaza, Tianshan RD, Shanghai, 200051, China Tel: 86-21-6228-9939 Fax: 86-21-6228-9936 sales@apacer.com.cn
India	Apacer Technologies Pvt Ltd, Unit No.201, "Brigade Corner", 7 th Block Jayanagar, Yediyur Circle, Bangalore – 560082, India Tel: 91-80-4152-9061 Fax: 91-80-4170-0215 sales_india@apacer.com