

RoHS Compliant

Serial ATA Flash Drive

mSATA A1 -MK Product Specifications

September 15th, 2014

Version 1.3



Apacer Technology Inc.

1F, No.32, Zhongcheng Rd., Tucheng Dist., New Taipei City, Taiwan, R.O.C

Tel: +886-2-2267-8000 Fax: +886-2-2267-2261

www.apacer.com

Features:

- **Compliance with SATA Revision 3.1**
 - Serial ATA Revision 3.1 specifications
 - SATA 6.0 Gbps interface
 - Backward compatible with SATA 1.5 and 3.0 Gbps interfaces
 - ATA-8 command set
- **Capacities**
 - 30, 60, 120, 240 GB
- **Performance***
 - Interface burst read/write: 600 MB/sec
 - Sustained read: up to 515 MB/sec
 - Sustained write: up to 285 MB/sec
 - Random read (4K): up to 69,000 IOPS
 - Random write (4K): up to 69,000 IOPS
- **Flash Management**
 - Built-in hardware ECC, enabling up to 40 bit correction per 1K bytes
 - Static/dynamic wear leveling
 - Flash bad-block management
 - S.M.A.R.T.
 - Power Failure Management
 - ATA Secure Erase
 - TRIM
- **NAND Flash Type: MLC**
- **Temperature ranges**
 - Operating: 0°C to 70°C
 - Storage: -40°C to 100°C
- **Supply voltage**
 - 3.3 V \pm 5%
- **Power consumption (typical)***
 - Active mode: 810 mA
 - Idle mode: 100 mA
- **Form factor**
 - JEDEC MO-300
- **Shock & Vibration****
 - Shock: 1500 G
 - Vibration: 15 G
- **DRAM cache for enhanced random performance**
- **SATA power management modes**
- **Device Sleep mode (optional)**
- **RoHS compliant**

*Varies from capacities. The values addressed here are typical and may vary depending on settings and platforms.

**Non-operating

Table of Contents

1. Product Description	3
1.1 Introduction	3
1.2 Capacity Specification.....	3
1.3 Performance.....	3
1.4 Pin Assignments.....	4
2. Software Interface	6
2.1 Command Set	6
2.2 S.M.A.R.T.....	6
3. Flash Management	8
3.1 Error Correction/Detection.....	8
3.2 Bad Block Management	8
3.3 Wear Leveling	8
3.4 Power Failure Management	8
3.5 ATA Secure Erase	8
3.6 TRIM	9
3.7 SATA Power Management	9
4. Reliability Specifications	10
4.1 Environmental	10
4.2 Mean Time Between Failures (MTBF).....	10
4.3 Certification and Compliance	10
5. Electrical Characteristics	11
5.1 Operating Voltage	11
5.2 Power Consumption	11
6. Mechanical Specifications	12
6.1 Dimensions	12
7. Product Ordering Information	12
7.1 Product Code Designations	13
7.2 Valid Combinations	14

1. Product Description

1.1 Introduction

Apacer's mSATA A1-MK is a well-balanced solid-state disk (SSD) drive with compact form factor (JEDEC MO-300) and great performance. Designed in SATA 6.0 Gbps interface, the mSATA SSD is able to deliver exceptional read/write speed, making it the ideal companion for heavy-loading embedded or server operations with space constraints for host computing systems. For data efficiency, the internal controlling unit of the mSATA SSD is engineered with DRAM for enhanced random performance. In regard of reliability, the drive comes with various implementations including powerful hardware ECC engine, power saving modes, wear leveling, flash block management, S.M.A.R.T., TRIM, and power failure management.

1.2 Capacity Specification

Table 1-1 Capacity specification

Capacity	Total Bytes	Cylinders	Heads	Sectors	Max LBA
30 GB	30,016,659,456	16,383	16	63	58,626,288
60 GB	60,022,480,896	16,383	16	63	117,231,408
120 GB	120,034,123,776	16,383	16	63	234,441,648
240 GB	240,057,409,536	16,383	16	63	468,862,128

1. Display of total bytes varies from file systems. 2. Cylinders, heads or sectors are not applicable for these capacities. Only LBA addressing applies. 3. LBA count addressed in the table above indicates total user storage capacity and will remain the same throughout the lifespan of the device. However, the total usable capacity of the SSD is most likely to be less than the total physical capacity because a small portion of the capacity is reserved for device maintenance usages.

1.3 Performance

Table 1-2 Performance

Capacity	30 GB	60 GB	120 GB	240 GB
Sustained Read (MB/s)	180	315	505	515
Sustained Write (MB/s)	38	75	135	285
Random Read IOPS (4K)	19,000	36,000	62,000	69,000
Random Write IOPS (4K)	9,000	18,000	33,000	69,000

Note: Performance varies from flash configurations or host system settings.
IOPS: measured on 8GB span (16777216 sectors Disk Size), 32 Outstanding I/Os (QD=32), Full Random Data pattern, 4KB Align I/Os and test durations 15minutes.

1.4 Pin Assignments

Pin assignment of the mSATA A1-MK is shown in Figure 1-1 and described in Table 1-3.

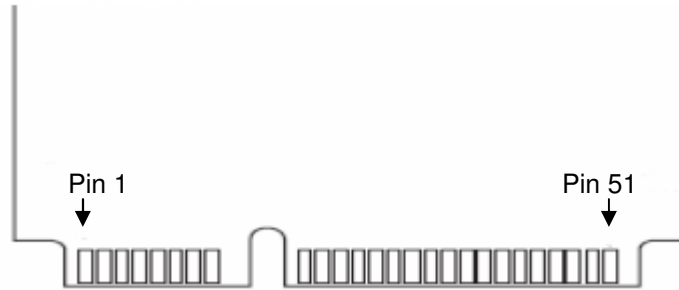

Figure 1-1 Apacer mSATA A1-MK pin assignment

Table 1-3 Pin Assignment Description

Pin	Type	Description	Pin	Type	Description
1	Reserved	No Connect	27	GND	Ground
2	+3.3V	3.3V source	28	Reserved	No Connect
3	Reserved	No Connect	29	GND	Ground
4	GND	Ground	30	Reserved	No Connect
5	Reserved	No Connect	31	-A	Host Transmitter Differential Signal Pair
6	Reserved	No Connect	32	Reserved	No Connect
7	Reserved	No Connect	33	+A	Host Transmitter Differential Signal Pair
8	Reserved	No Connect	34	GND	Ground
9	GND	Ground	35	GND	Ground
10	Reserved	No Connect	36	Reserved	No Connect
11	Reserved	No Connect	37	GND	Ground
12	Reserved	No Connect	38	Reserved	No Connect
13	Reserved	No Connect	39	+3.3V	3.3V source
14	Reserved	No Connect	40	GND	Ground
15	GND	Ground	41	+3.3V	3.3V source
16	Reserved	No Connect	42	Reserved	No Connect
17	Reserved	No Connect	43	Device Type	No Connect
18	GND	Ground	44*	DEVSLP	Device Sleep
19	Reserved	No Connect	45	Reserved	No Connect
20	Reserved	No Connect	46	Reserved	No Connect
21	GND	Ground	47	Reserved	No Connect
22	Reserved	No Connect	48	Reserved	No Connect
23	+B	Host Receiver Differential Signal Pair	49	DAS/DSS	Device Activity Signal/Disable Staggered Spin-up
24	+3.3V	3.3V Source	50	GND	Ground
25	-B	Host Receiver Differential Signal Pair	51**	Detect	0 ohm
26	GND	Ground	52	+3.3V	3.3V source

*Pin44 can be configured as Device Sleep enabling pin by option.

**Notes about Pin51: It is a presence detection pin that shall be connected to GND by a 0 ohm to 220 ohm Resistor on device. Please see the diagram below.

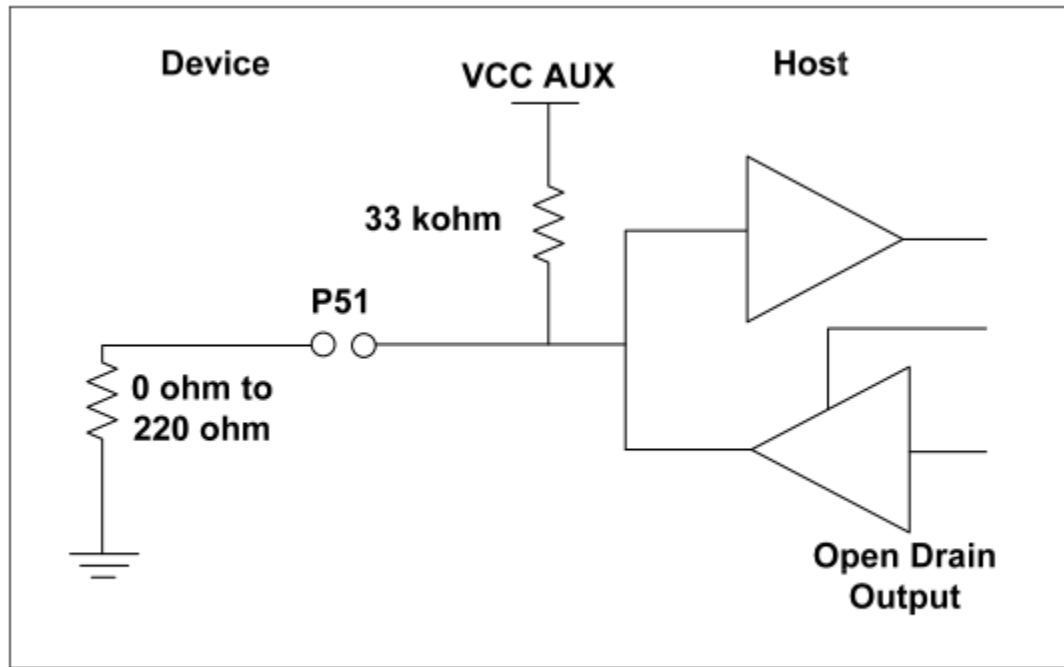

BI-directional host-side implementation of P51 for compatibility with non-mSATA devices (Informative)

2. Software Interface

2.1 Command Set

Table 2-1 summarizes the ATA commands supported by mSATA A1-MK.

Table 2-1: Command set

Code	Command	Code	Command
E5h	Check Power Mode	F6h	Security Disable Password
90h	Execute Diagnostics	F3h	Security Erase Prepare
E7h	Flush Cache	F4h	Security Erase Unit
ECh	Identify Device	F5h	Security Freeze Lock
E3h	Idle	F1h	Security Set Password
E1h	Idle Immediate	F2h	Security Unlock
91h	Initialize Device Parameters	7xh	Seek
C8h	Read DMA	EFh	Set Features
25h	Read DMA EXT	C6h	Set Multiple Mode
60h	Read FPDMA Queued	E6h	Sleep
47h	Read Log DMA EXT	B0h	S.M.A.R.T.
2Fh	Read Log EXT	E2h	Standby
C4h	Read Multiple	E0h	Standby Immediate
20 or 21h	Read Sector(s)	CAh	Write DMA
40 or 41h	Read Verify Sector(s)	35h	Write DMA EXT
10h	Recalibrate	61h	Write FPDMA Queued
57h	Write Log DMA EXT	3Fh	Write Log EXT
C5h	Write Multiple	30h or 31h	Write Sector(s)

2.2 S.M.A.R.T.

S.M.A.R.T. is an abbreviation for Self-Monitoring, Analysis and Reporting Technology, a self-monitoring system that provides indicators of drive health as well as potential disk problems. It serves as a warning for users from unscheduled downtime by monitoring and displaying critical drive information. Ideally, this should allow taking proactive actions to prevent drive failure and make use of S.M.A.R.T. information for future product development reference.

Apacer devices use the standard SMART command B0h to read data out from the drive to activate our S.M.A.R.T. feature that complies with the ATA/ATAPI specifications. S.M.A.R.T. Attribute IDs shall include initial bad block count, total later bad block count, maximum erase count, average erase count, power on hours and power cycle. When the S.M.A.R.T. Utility running on the host, it analyzes and reports the disk status to the host before the device reaches in critical condition.

Note: attribute IDs may vary from product models due to various solution design and supporting capabilities.

Serial ATA Flash Drive

APSDMxxxxMXAN-2XXM

Apacer memory products come with S.M.A.R.T. commands and subcommands for users to obtain information of drive status and to predict potential drive failures. Users can take advantage of the following commands/subcommands to monitor the health of the drive.

Code	SMART Subcommand
D0h	READ DATA
D1h	READ ATTRIBUTE THRESHOLDS
D2h	Enable/Disable Attribute Autosave
D4h	Execute Off-line Immediate
D5h	Read Log (optional)
D6h	Write Log (optional)
D8h	Enable Operations
D9h	Disable operations
DAh	Return Status

General SMART attribute structure

Byte	Description
0	ID (Hex)
1 – 2	Status flag
3	Value
4	Worst
5*-11	Raw Data

*Byte 5: LSB

SMART attribute ID list

ID (Hex)	Attribute Name
9 (0x09)	Power-on hours
12 (0x0C)	Power cycle count
163 (0xA3)	Max. erase count
164 (0xA4)	Avg. erase count
166 (0xA6)	Total later bad block count
167 (0xA7)	SSD Protect Mode (vendor specific)
168 (0xA8)	SATA PHY Error Count
175 (0xAF)	Bad Cluster Table Count
192 (0xC0)	Unexpected Power Loss Count
194 (0xC2)	Temperature
241 (0xF1)	Total sectors of write

3. Flash Management

3.1 Error Correction/Detection

mSATA A1-MK implements a hardware ECC scheme, based on the BCH algorithm. It can detect and correct up to 40 bits error in 1K bytes.

3.2 Bad Block Management

Current production technology is unable to guarantee total reliability of NAND flash memory array. When a flash memory device leaves factory, it comes with a minimal number of initial bad blocks during production or out-of-factory as there is no currently known technology that produce flash chips free of bad blocks. In addition, bad blocks may develop during program/erase cycles. When host performs program/erase command on a block, bad block may appear in Status Register. Since bad blocks are inevitable, the solution is to keep them in control. Apacer flash devices are programmed with ECC, block mapping technique and S.M.A.R.T to reduce invalidity or error. Once bad blocks are detected, data in those blocks will be transferred to free blocks and error will be corrected by designated algorithms.

3.3 Wear Leveling

Flash memory devices differ from Hard Disk Drives (HDDs) in terms of how blocks are utilized. For HDDs, when a change is made to stored data, like erase or update, the controller mechanism on HDDs will perform overwrites on blocks. Unlike HDDs, flash blocks cannot be overwritten and each P/E cycle wears down the lifespan of blocks gradually. Repeatedly program/erase cycles performed on the same memory cells will eventually cause some blocks to age faster than others. This would bring flash storages to their end of service term sooner. Wear leveling is an important mechanism that level out the wearing of blocks so that the wearing-down of blocks can be almost evenly distributed. This will increase the lifespan of SSDs. Commonly used wear leveling types are Static and Dynamic.

3.4 Power Failure Management

Power Failure Management plays a crucial role when experiencing unstable power supply. Power disruption may occur when users are storing data into the SSD. In this urgent situation, the controller would run multiple write-to-flash cycles to store the metadata for later block rebuilding. This urgent operation requires about several milliseconds to get it done. At the next power up, the firmware will perform a status tracking to retrieve the mapping table and resume previously programmed NAND blocks to check if there is any incompleteness of transmission.

Note: The controller unit of this product model is designed with a DRAM as a write cache for improved performance and data efficiency. Though unlikely to happen in most cases, the data cached in the volatile DRAM might be potentially affected if a sudden power loss takes place before the cached data is flushed into non-volatile NAND flash memory.

3.5 ATA Secure Erase

ATA Secure Erase is an ATA disk purging command currently embedded in most of the storage drives. Defined in ATA specifications, (ATA) Secure Erase is part of Security Feature Set that allows storage drives to erase all user data areas. The erase process usually runs on the firmware level as most of the ATA-based storage media currently in the market are built-in with this command. ATA Secure Erase can securely wipe out the user data in the drive and protects it from malicious attack.

3.6 TRIM

TRIM is a SATA command that helps improve the read/write performance and efficiency of solid-state drives (SSD). The command enables the host operating system to inform SSD controller which blocks contain invalid data, mostly because of the erase commands from host. The invalid will be discarded permanently and the SSD will retain more space for itself.

3.7 SATA Power Management

By complying with SATA 6.0 Gb/s specifications, the SSD supports the following SATA power saving modes:

- ACTIVE: PHY ready, full power, Tx & Rx operational
- PARTIAL: Reduces power, resumes in under 10 μ s (microseconds)
- SLUMBER: Reduces power, resumes in under 10 ms (milliseconds)
- HIPM: Host-Initiated Power Management
- DIPM: Device-Initiated Power Management
- AUTO-SLUMBER: Automatic transition from partial to slumber.
- Device Sleep (DevSleep or DEVSLP): PHY powered down; power consumption \leq 5 mW; host assertion time \leq 10 ms; exit timeout from this state \leq 20 ms (unless specified otherwise in SATA Identify Device Log).

Note:

1. The behaviors of power management features would depend on host/device settings.
2. Device Sleep mode is optional, depending on product ordering selections.

4. Reliability Specifications

4.1 Environmental

mSATA A1-MK environmental specifications follow MIL-STD-810F, as indicated in the following table.

Table 4-1 mSATA A1-MK environmental specifications

Environment	Specification
Temperature	0°C to 70°C (Operating)
	-40°C to 100°C (Non-operating)
Vibration	Non-operating : Sine wave, 15(G), 10~2000(Hz), Operating : Random, 7.69(Grms), 20~2000(Hz)
Shock	Non-operating: Acceleration, 1,500 G, 0.5 ms Operating: Peak acceleration, 50 G, 11 ms

4.2 Mean Time Between Failures (MTBF)

Mean Time Between Failures (MTBF) is predicted based on reliability data for the individual components in SATA drive. The prediction result for the mSATA A1-MK is more than 1,000,000 hours.

Notes about the MTBF: the MTBF is predicated and calculated based on “Telcordia Technologies Special Report, SR-332, Issue 2” method.

4.3 Certification and Compliance

mSATA A1-MK complies with the following standards:

- CE
- FCC
- RoHS
- MIL-STD-810F

5. Electrical Characteristics

5.1 Operating Voltage

Table 5-1 lists the supply voltage for mSATA A1-MK.

Table 5-1 mSATA A1-MK operating voltage

Parameter	Conditions
Supply voltage	3.3V \pm 5%

5.2 Power Consumption

Table 5-2 Power consumption

Mode \ Capacity	30 GB	60 GB	120 GB	240 GB
Active (mA)	270	350	490	810
Idle (mA)	75	100	100	100

Note: Results may differ from various flash configurations or host system setting

6. Mechanical Specifications

6.1 Dimensions

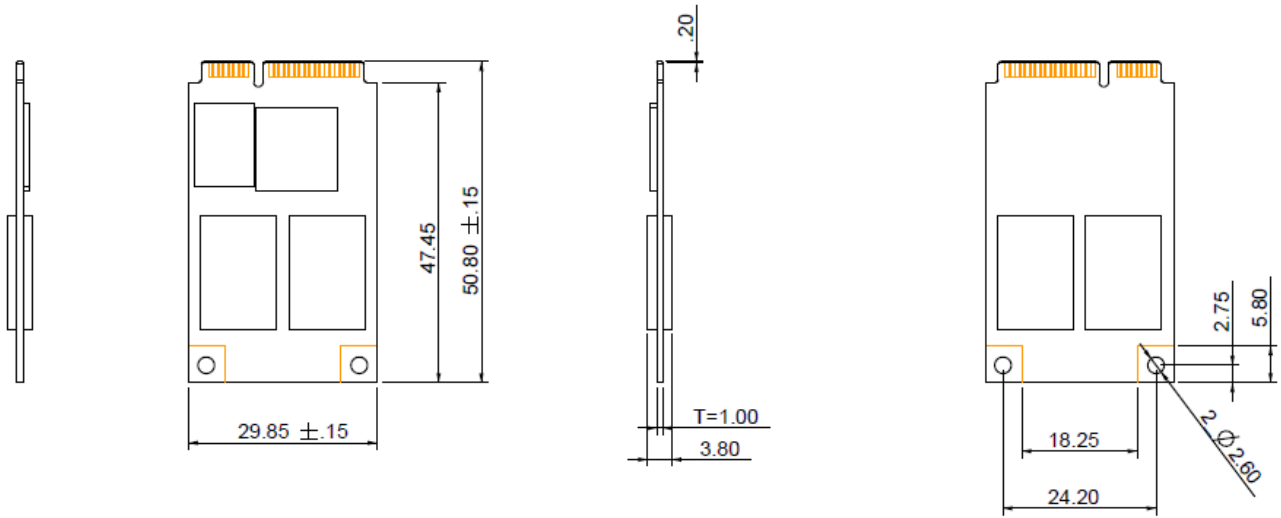

Unit: mm
Tolerance: ± 0.2

7. Product Ordering Information

7.1 Product Code Designations

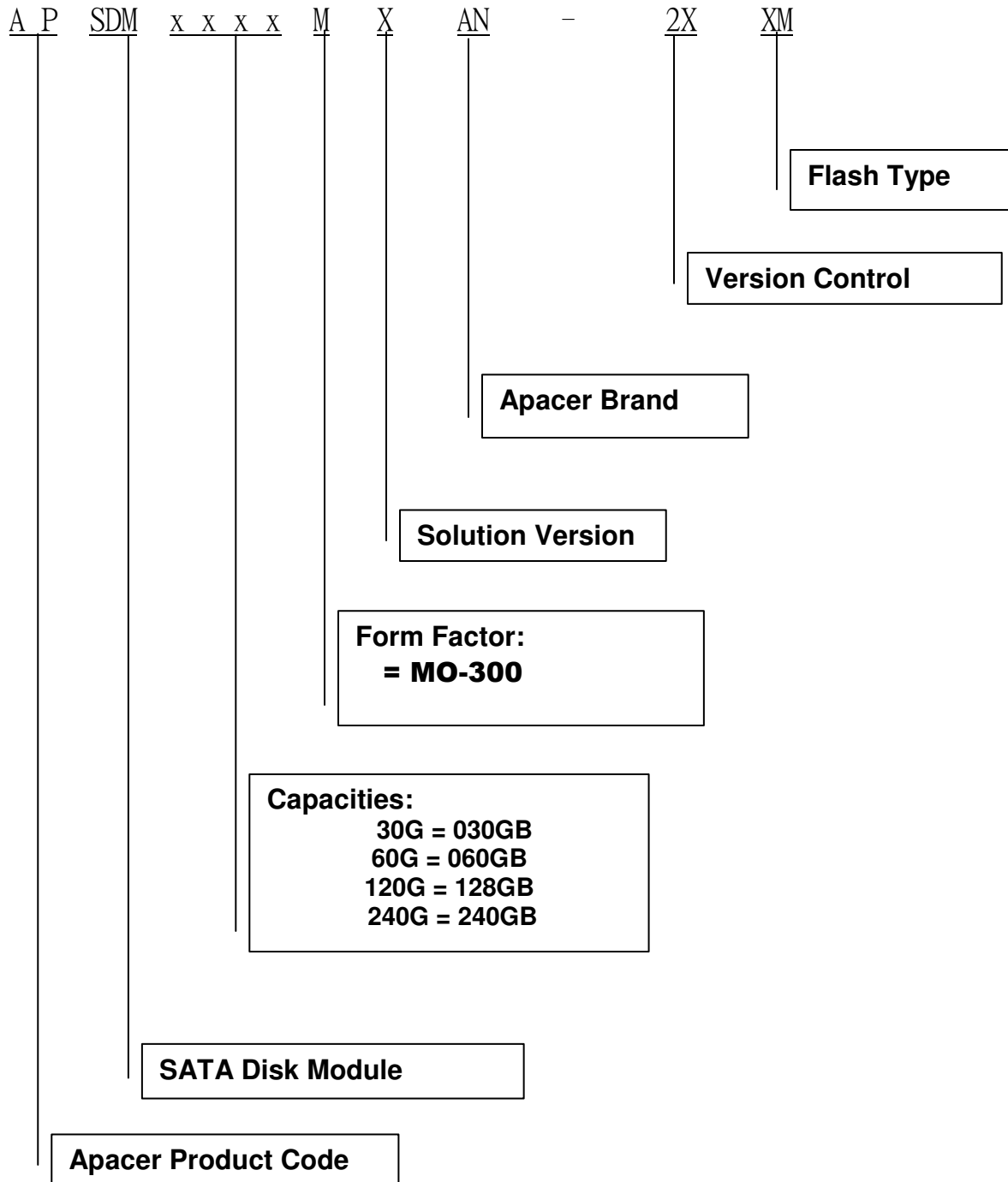

7.2 Valid Combinations

Capacity	NO DEVSLP	DEVSLP
30GB	APSDM030GM4AN-2ACM	APSDM030GM4AN-2BCM
60GB	APSDM060GM9AN-2ACM	APSDM060GM9AN-2BCM
120GB	APSDM120GM9AN-2ALM	APSDM120GM9AN-2BLM
240GB	APSDM240GM9AN-2ALM	APSDM240GM9AN-2BLM

Note: please contact Apacer sales representatives for availabilities.

Revision History

Revision	Description	Date
0.1	Preliminary	03/10/2014
0.2	Revised the 60GB performance	03/11/2014
0.3	Removed "DSS" from pin49	03/14/2014
1.0	Official release	03/27/2014
1.1	Updated product ordering information due to changes in NAND flash use for 30GB and 60GB	04/17/2014
1.2	Revised performance information	05/21/2014
1.3	Revised pin assignments	09/15/2014

Global Presence

Taiwan (Headquarters)

Apacer Technology Inc.
Apacer Technology Inc.
1F., No.32, Zhongcheng Rd., Tucheng Dist.,
New Taipei City 236, Taiwan R.O.C.
Tel: 886-2-2267-8000
Fax: 886-2-2267-2261
amtsales@apacer.com

U.S.A.

Apacer Memory America, Inc.
386 Fairview Way, Suite102,
Milpitas, CA 95035
Tel: 1-408-518-8699
Fax: 1-408-935-9611
sa@apacerus.com

Japan

Apacer Technology Corp.
5F, Matsura Bldg., Shiba, Minato-Ku
Tokyo, 105-0014, Japan
Tel: 81-3-5419-2668
Fax: 81-3-5419-0018
jpsservices@apacer.com

Europe

Apacer Technology B.V.
Science Park Eindhoven 5051 5692 EB Son,
The Netherlands
Tel: 31-40-267-0000
Fax: 31-40-267-0000#6199
sales@apacer.nl

China

Apacer Electronic (Shanghai) Co., Ltd
1301, No.251,Xiaomuqiao Road, Shanghai,
200032, China
Tel: 86-21-5529-0222
Fax: 86-21-5206-6939
sales@apacer.com.cn

India

Apacer Technologies Pvt Ltd,
535, 1st Floor, 8th cross, JP Nagar 3rd Phase,
Bangalore – 560078, India
Tel: 91-80-4152-9061
sales_india@apacer.com