

RoHS Recast Compliant
Serial ATA Flash Drive
SM210-M280 Product Specifications

July 9, 2018

Version 1.3



Apacer Technology Inc.

1F, No.32, Zhongcheng Rd., Tucheng Dist., New Taipei City, Taiwan, R.O.C

Tel: +886-2-2267-8000 Fax: +886-2-2267-2261

www.apacer.com

Specifications Overview:

- **Standard SATA Interface Compliance**
 - Serial ATA Revision 3.2 compliance
 - SATA 6.0 Gbps interface
 - ATA-8 command set
- **Capacity**
 - Single side: 32, 64, 128, 256 GB
 - Double side: 512 GB
- **Performance***
 - Burst read/write: 600 MB/sec
 - Sequential read: Up to 540 MB/sec
 - Sequential write: Up to 490 MB/sec
 - Random read (4K): Up to 82,000 IOPS
 - Random write (4K): Up to 78,000 IOPS
- **Flash Management**
 - Built-in hardware ECC
 - Global Wear Leveling
 - Flash bad-block management
 - S.M.A.R.T.
 - Power Failure Management
 - Device Sleep (optional)
 - ATA Secure Erase
 - TRIM
- **Endurance (in Terabytes Written: TBW)**
 - 32 GB: 61 TBW
 - 64 GB: 129 TBW
 - 128 GB: 276 TBW
 - 256 GB: 586 TBW
 - 512 GB: 1,142 TBW
- **Temperature Range**
 - Operating:
 - Standard: 0°C to 70°C
 - Extended: -40°C to 85°C
 - Storage: -40°C to 100°C
- **Supply Voltage**
 - 3.3 V ± 5%
- **Power Consumption***
 - Active mode: 975 mA
 - Idle mode: 155 mA
- **Connector Type**
 - 75-pin SATA-based M.2 module pinout
- **NAND Flash Type: MLC**
- **MTBF: >1,000,000 hours**
- **Form Factor**
 - M.2 2280-D5-B-M form factor
 - Dimensions:
 - Single side: 80.00 x 22.00 x 2.23, unit: mm
 - Double side: 80.00 x 22.00 x 3.58, unit: mm
- **Reliability**
 - Thermal Sensor
- **DRAM Cache for Enhanced Random Performance**
- **Shock & Vibration****
 - Shock: 1,500 G
 - Vibration: 15 G
- **RoHS Recast Compliant (Complies with 2011/65/EU Standard)**

*Varies from capacities. The values for performances and power consumptions presented are typical and may vary depending on flash configurations or platform settings. The term idle refers to the standby state of the device.

**Non-operating

Table of Contents

| | |
|---|-----------|
| 1. General Descriptions | 3 |
| 2. Pin Assignments..... | 4 |
| 3. Product Specifications..... | 7 |
| 3.1 Capacity..... | 7 |
| 3.2 Performance | 7 |
| 3.3 Environmental Specifications | 8 |
| 3.4 Mean Time Between Failures (MTBF) | 8 |
| 3.5 Certification and Compliance | 8 |
| 3.6 Endurance | 9 |
| 4. Flash Management..... | 10 |
| 4.1 Error Correction/Detection..... | 10 |
| 4.2 Bad Block Management | 10 |
| 4.3 Global Wear Leveling | 10 |
| 4.4 ATA Secure Erase..... | 10 |
| 4.5 Power Failure Management | 10 |
| 4.6 TRIM..... | 11 |
| 4.7 SATA Power Management..... | 11 |
| 5. Reliability Features | 12 |
| 5.1 Thermal Sensor | 12 |
| 6. Software Interface | 13 |
| 6.1 Command Set..... | 13 |
| 6.2 S.M.A.R.T..... | 13 |
| 7. Electrical Specifications | 15 |
| 7.1 Operating Voltage..... | 15 |
| 7.2 Power Consumption | 15 |
| 8. Physical Characteristics..... | 16 |
| 8.1 Single Side | 16 |
| 8.2 Double Side | 17 |
| 9. Product Ordering Information..... | 18 |
| 9.1 Product Code Designations..... | 18 |
| 9.2 Valid Combinations..... | 19 |

1. General Descriptions

Apacer's SM210-M280 is the next generation modularized Solid State Drive (SSD) with the shape of all new M.2 form factor, aimed to be the more suitable for mobile and compact computers with standard width at only 22.00 mm. SM210-M280 appears in M.2 2280 mechanical dimensions and is believed to be the leading add-in storage solution for future host computing systems.

The M.2 SSD is designed with SATA-based connector pinouts, providing full compliance with the latest SATA Revision 3.2 interface specifications. Aside from SATA compliance, SM210-M280 delivers exceptional performance and power efficiency. On the other hand, the extreme thin and light form factor makes SM210-M280 the ideal choice for mobile computing systems, which appears to be the trend in near future.

Regarding reliability, SM210-M280 is built with a powerful SATA controller that supports on-the-module ECC as well as efficient wear leveling scheme. In terms of power efficiency, SM210-M280 is compliant with SATA 6.0 Gbps interface standard so that it can operate on SATA power management modes, which greatly save on power consumption.

2. Pin Assignments

This connector does not support hot plug capability. There are a total of 75 pins. 12 pin locations are used for mechanical key locations; this allows such a module to plug into both Key B and Key M connectors.

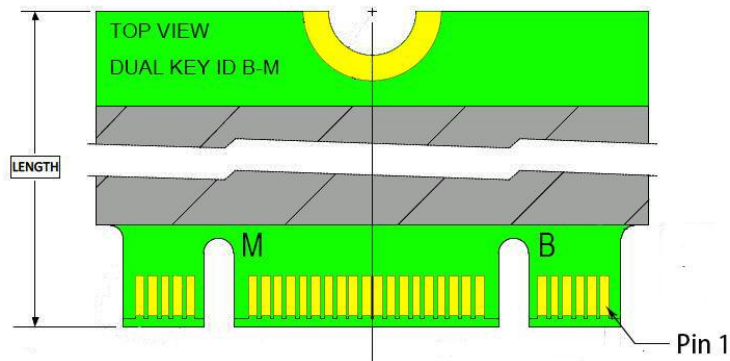

Table 2-1 Pin Assignments

| Pin | Type | Description |
|-----|-------------------|--|
| 1 | CONFIG_3 | Ground (according to M.2 configurations for SSD-SATA definition) |
| 2 | 3.3V | Supply Pin, 3.3V |
| 3 | GND | Ground |
| 4 | 3.3V | Supply pin, 3.3V |
| 5 | No connect | No connect |
| 6 | Not available | No connect (used for other purposes) |
| 7 | Not available | No connect (used for other purposes) |
| 8 | Not available | No connect (used for other purposes) |
| 9 | No connect | No connect |
| 10 | DAS/DSS | Device Activity Signal/Disable Staggered Spin-up |
| 11 | No connect | No connect (used for other purposes) |
| 12 | (removed for key) | Mechanical notch B |
| 13 | (removed for key) | Mechanical notch B |
| 14 | (removed for key) | Mechanical notch B |
| 15 | (removed for key) | Mechanical notch B |
| 16 | (removed for key) | Mechanical notch B |
| 17 | (removed for key) | Mechanical notch B |
| 18 | (removed for key) | Mechanical notch B |
| 19 | (removed for key) | Mechanical notch B |
| 20 | Not available | No connect (used for other purposes) |
| 21 | CONFIG_0 | Ground (according to M.2 configurations for SSD-SATA definition) |
| 22 | Not available | No connect (used for other purposes) |
| 23 | Not available | No connect (used for other purposes) |
| 24 | Not available | No connect (used for other purposes) |
| 25 | Not available | No connect (used for other purposes) |
| 26 | Not available | No connect (used for other purposes) |
| 27 | GND | Ground |
| 28 | Not available | No connect (used for other purposes) |
| 29 | PERn1 | Not used |
| 30 | Not available | No connect (used for other purposes) |
| 31 | PERp1 | Not used |
| 32 | Not available | No connect (used for other purposes) |
| 33 | GND | Ground |
| 34 | Not available | No connect (used for other purposes) |

Table 2-1 Pin Assignments

| Pin | Type | Description |
|-----|-------------------|--|
| 35 | PETn1 | Not used |
| 36 | Not available | No connect (used for other purposes) |
| 37 | PETp1 | Not used |
| 38 | DEVSLP | Device Sleep, input. If driven high the host is informing the SSD to enter a low power state |
| 39 | GND | Ground |
| 40 | Not available | No connect (used for other purposes) |
| 41 | SATA-Rx+ | Host receiver differential signal pair |
| 42 | Not available | No connect (used for other purposes) |
| 43 | SATA-Rx- | Host receiver differential signal pair |
| 44 | Not available | No connect (used for other purposes) |
| 45 | GND | Ground |
| 46 | Not available | No connect (used for other purposes) |
| 47 | SATA-Tx- | Host transmitter differential pair |
| 48 | Not available | No connect (used for other purposes) |
| 49 | SATA-Tx+ | Host transmitter differential pair |
| 50 | PERST# | Not used |
| 51 | GND | Ground |
| 52 | CLKREQ# | Not used |
| 53 | REFCLKN | Not used |
| 54 | PEWAKE# | Not used |
| 55 | REFCLKP | Not used |
| 56 | MFG1 | Manufacturing pin. Use determined by vendor (no connect on a host) |
| 57 | GND | Ground |
| 58 | MFG2 | Manufacturing pin. Use determined by vendor (no connect on a host) |
| 59 | (removed for key) | Mechanical notch M |
| 60 | (removed for key) | Mechanical notch M |
| 61 | (removed for key) | Mechanical notch M |
| 62 | (removed for key) | Mechanical notch M |
| 63 | (removed for key) | Mechanical notch M |
| 64 | (removed for key) | Mechanical notch M |
| 65 | (removed for key) | Mechanical notch M |
| 66 | (removed for key) | Mechanical notch M |
| 67 | Not available | No connect (used for other purposes) |
| 68 | SUSCLK | Not used |
| 69 | CONFIG_1 | Ground |
| 70 | 3.3V | Supply pin, 3.3V |
| 71 | GND | Ground |
| 72 | 3.3V | Supply pin, 3.3V |
| 73 | GND | Ground |
| 74 | 3.3V | Supply pin, 3.3V |
| 75 | CONFIG_2 | Ground |

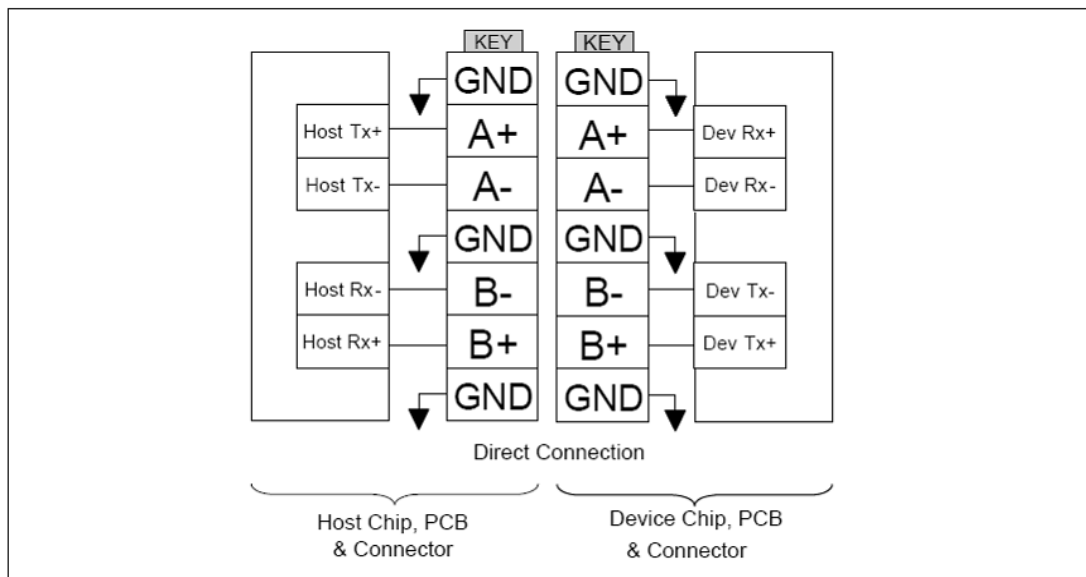

Figure 2-1 Direct Connection between the Host and Device

3. Product Specifications

3.1 Capacity

Capacity specifications of SM210-M280 are available as shown in Table 3-1. It lists the specific capacity and the default numbers of heads, sectors and cylinders for each product line.

Table 3-1 Capacity Specifications

| Capacity | Total bytes* | Cylinders | Heads | Sectors | Max LBA |
|----------|-----------------|-----------|-------|---------|---------------|
| 32 GB | 32,017,047,552 | 16,383 | 16 | 63 | 62,533,296 |
| 64 GB | 64,023,257,088 | 16,383 | 16 | 63 | 125,045,424 |
| 128 GB | 128,035,676,160 | 16,383 | 16 | 63 | 250,069,680 |
| 256 GB | 256,060,514,304 | 16,383 | 16 | 63 | 500,118,192 |
| 512 GB | 512,110,190,592 | 16383 | 16 | 63 | 1,000,215,216 |

*Display of total bytes varies from file systems, which means not all of the bytes can be used for storage.

**Notes: 1 GB = 1,000,000,000 bytes; 1 sector = 512 bytes.

LBA count addressed in the table above indicates total user storage capacity and will remain the same throughout the lifespan of the device. However, the total usable capacity of the SSD is most likely to be less than the total physical capacity because a small portion of the capacity is reserved for device maintenance usages.

3.2 Performance

Performance of SM210-M280 is listed below in Table 3-2.

Table 3-2 Performance Specifications

| Performance | Capacity | 32 GB | 64 GB | 128 GB | 256 GB | 512 GB*** |
|---------------------------------|--------------------------------|--------|--------|--------|--------|-----------|
| | Sequential Read* (MB/s) | | 360 | 360 | 510 | 495 |
| Sequential Write* (MB/s) | | 100 | 90 | 185 | 345 | 475 |
| Random Read IOPS** (4K) | | 48,000 | 45,000 | 75,000 | 82,000 | 57,000 |
| Random Write IOPS** (4K) | | 24,000 | 22,000 | 44,000 | 78,000 | 29,000 |

Note:

Results may differ from various flash configurations or host system setting.

*Sequential performance is based on CrystalDiskMark 5.2.1 with file size 1,000MB.

**Random performance measured using IOMeter with Queue Depth 32.

***512GB adopts 8K mapping algorithm.

3.3 Environmental Specifications

Environmental specifications of SM210-M280 product are shown in Table 3-3.

Table 3-3 Environmental Specifications

| Environment | Specifications |
|-------------|---|
| Temperature | 0°C to 70°C (Standard); -40°C to 85°C (Extended) |
| | -40°C to 100°C (Non-operating) |
| Vibration | Non-operating: Sine wave, 15(G), 10~2000(Hz), Operating: Random, 7.69(GRMS), 20~2000(Hz) |
| Shock | Non-operating: Acceleration, 1,500 G, 0.5 ms Operating: Peak acceleration, 50 G, 11 ms |

3.4 Mean Time Between Failures (MTBF)

Mean Time Between Failures (MTBF) is predicted based on reliability data for the individual components in SM210-M280. The prediction result for SM210-M280 is more than 1,000,000 hours.

Note: The MTBF is predicated and calculated based on “Telcordia Technologies Special Report, SR-332, Issue 2” method.

3.5 Certification and Compliance

SM210-M280 complies with the following standards:

- CE
- FCC
- RoHS Recast
- MIL-STD-810

3.6 Endurance

The endurance of a storage device is predicted by TeraBytes Written based on several factors related to usage, such as the amount of data written into the drive, block management conditions, and daily workload for the drive. Thus, key factors, such as Write Amplifications and the number of P/E cycles, can influence the lifespan of the drive.

Table 3-4 Endurance Specifications

| Capacity | TeraBytes Written |
|----------|-------------------|
| 32 GB | 61 |
| 64 GB | 129 |
| 128 GB | 276 |
| 256 GB | 586 |
| 512 GB | 1,142 |

Note:

- The measurement assumes the data written to the SSD for test is under a typical and constant rate.
- The measurement follows the standard metric: 1 TB (Terabyte) = 1,000 GB.
- This estimation complies with JEDEC JESD-219, enterprise endurance workload of random data with payload size distribution.

4. Flash Management

4.1 Error Correction/Detection

SM210-M280 implements a hardware ECC scheme, based on the BCH algorithm. It can detect and correct up to 72 bits error in 1K bytes.

4.2 Bad Block Management

Current production technology is unable to guarantee total reliability of NAND flash memory array. When a flash memory device leaves factory, it comes with a minimal number of initial bad blocks during production or out-of-factory as there is no currently known technology that produce flash chips free of bad blocks. In addition, bad blocks may develop during program/erase cycles. When host performs program/erase command on a block, bad block may appear in Status Register. Since bad blocks are inevitable, the solution is to keep them in control. Apacer flash devices are programmed with ECC, page mapping technique and S.M.A.R.T to reduce invalidity or error. Once bad blocks are detected, data in those blocks will be transferred to free blocks and error will be corrected by designated algorithms.

4.3 Global Wear Leveling

Flash memory devices differ from Hard Disk Drives (HDDs) in terms of how blocks are utilized. For HDDs, when a change is made to stored data, like erase or update, the controller mechanism on HDDs will perform overwrites on blocks. Unlike HDDs, flash blocks cannot be overwritten and each P/E cycle wears down the lifespan of blocks gradually. Repeatedly program/erase cycles performed on the same memory cells will eventually cause some blocks to age faster than others. This would bring flash storages to their end of service term sooner. Global wear leveling is an important mechanism that levels out the wearing of all blocks so that the wearing-down of all blocks can be almost evenly distributed. This will increase the lifespan of SSDs.

4.4 ATA Secure Erase

ATA Secure Erase is an ATA disk purging command currently embedded in most of the storage drives. Defined in ATA specifications, (ATA) Secure Erase is part of Security Feature Set that allows storage drives to erase all user data areas. The erase process usually runs on the firmware level as most of the ATA-based storage media currently in the market are built-in with this command. ATA Secure Erase can securely wipe out the user data in the drive and protects it from malicious attack.

4.5 Power Failure Management

Power Failure Management plays a crucial role when experiencing unstable power supply. Power disruption may occur when users are storing data into the SSD. In this urgent situation, the controller would run multiple write-to-flash cycles to store the metadata for later block rebuilding. This urgent operation requires about several milliseconds to get it done. At the next power up, the firmware will perform a status tracking to retrieve the mapping table and resume previously programmed NAND blocks to check if there is any incompleteness of transmission.

Note: The controller unit of this product model is designed with a DRAM as a write cache for improved performance and data efficiency. Though unlikely to happen in most cases, the data cached in the volatile DRAM might be potentially affected if a sudden power loss takes place before the cached data is flushed into non-volatile NAND flash memory.

4.6 TRIM

TRIM, though in capital letters usually, is a memory computation command rather than an abbreviation. It is mainly a SATA command that enables the operating system to inform the SSD (Solid State Drive) which blocks of previously stored data are no longer valid, due to erases by the host or operating system, such as file deletions or disk formatting. Once notified, SSD will begin the discard of the invalid LBAs and retain more space for itself, in fact, the discarded is no longer recoverable.

When an LBA is replaced by the operating system, as with overwrite of a file, the SSD is informed that the originally occupied LBA is determined as no longer in use or invalid. The SSD will not save those blocks in garbage collected sectors. Noticeably, a file deletion command by host or operating system never actually erases the actual content, but marks the file as deleted. This issue is even specifically noticeable for flash based memory devices, such as SSDs. In fact, an SSD will keep garbage collecting the invalid, previously occupied LBAs, if it is not informed that these LBAs can be erased. Thus, the SSD would experience a significant performance downfall.

4.7 SATA Power Management

By complying with SATA 6.0 Gb/s specifications, the SSD supports the following SATA power saving modes:

- ACTIVE: PHY ready, full power, Tx & Rx operational
- PARTIAL: Reduces power, resumes in under 10 μ s (microseconds)
- SLUMBER: Reduces power, resumes in under 10 ms (milliseconds)
- HIPM: Host-Initiated Power Management
- DIPM: Device-Initiated Power Management
- AUTO-SLUMBER: Automatic transition from partial to slumber.
- Device Sleep (DevSleep or DEVSLP): PHY powered down; power consumption \leq 5 mW; host assertion time \leq 10 ms; exit timeout from this state \leq 20 ms (unless specified otherwise in SATA Identify Device Log).

Note:

1. The behaviors of power management features would depend on host/device settings.
2. Device Sleep mode is optional depending on product ordering selections.

5. Reliability Features

5.1 Thermal Sensor

Apacer Thermal Sensor is a digital temperature sensor with serial interface. By using a designated pin for transmission, storage device owners are able to read temperature data.

6. Software Interface

This section defines the software requirements and the format of the commands the host sends to SM210-M280. Commands are issued to SM210-M280 by loading the required registers in the command block with the supplied parameters, and then writing the command code to the Command register.

6.1 Command Set

Table 6-1 Command Set

| Code | Command | Code | Command |
|------|------------------------------|------|------------------------|
| E5h | Check Power Mode | F3h | Security Erase Prepare |
| 06h | Data Set Management | F4h | Security Erase Unit |
| 90h | Execute Device Diagnostic | F5h | Security Freeze Lock |
| E7h | Flush Cache | F1h | Security Set Password |
| EAh | Flush Cache EXT | F2h | Security Unlock |
| ECh | Identify Device | 70h | Seek |
| E3h | Idle | EFh | Set Features |
| E1h | Idle Immediate | C6h | Set Multiple Mode |
| 91h | Initialize Device Parameters | E6h | Sleep |
| C8h | Read DMA | B0h | SMART |
| 25h | Read DMA EXT | E2h | Standby |
| C4h | Read Multiple | E0h | Standby Immediate |
| 29h | Read Multiple EXT | CAh | Write DMA |
| 20h | Read Sector | 35h | Write DMA EXT |
| 24h | Read Sector EXT | C5h | Write Multiple |
| 40h | Read Verify Sectors | 39h | Write Multiple EXT |
| 42h | Read Verify Sectors EXT | 30h | Write Sector |
| 10h | Recalibrate | 34h | Write Sector EXT |
| F6h | Security Disable Password | | |

6.2 S.M.A.R.T.

S.M.A.R.T. is an abbreviation for Self-Monitoring, Analysis and Reporting Technology, a self-monitoring system that provides indicators of drive health as well as potential disk problems. It serves as a warning for users from unscheduled downtime by monitoring and displaying critical drive information. Ideally, this should allow taking proactive actions to prevent drive failure and make use of S.M.A.R.T. information for future product development reference.

Apacer devices use the standard SMART command B0h to read data out from the drive to activate our S.M.A.R.T. feature that complies with the ATA/ATAPI specifications. S.M.A.R.T. Attribute IDs shall include initial bad block count, total later bad block count, maximum erase count, average erase count, power on hours and power cycle. When the S.M.A.R.T. Utility running on the host, it analyzes and reports the disk status to the host before the device reaches in critical condition.

Note: Attribute IDs may vary from product models due to various solution design and supporting capabilities.

Apacer memory products come with S.M.A.R.T. commands and subcommands for users to obtain information of drive status and to predict potential drive failures. Users can take advantage of the following commands/subcommands to monitor the health of the drive.

| Code | SMART Subcommand |
|------|-----------------------------------|
| D0h | READ DATA |
| D1h | READ ATTRIBUTE THRESHOLDS |
| D2h | Enable/Disable Attribute Autosave |
| D4h | Execute Off-line Immediate |
| D5h | Read Log (optional) |
| D6h | Write Log (optional) |
| D8h | Enable Operations |
| D9h | Disable operations |
| DAh | Return Status |

General SMART attribute structure

| Byte | Description |
|-------|-------------|
| 0 | ID (Hex) |
| 1 – 2 | Status flag |
| 3 | Value |
| 4 | Worst |
| 5*-11 | Raw Data |

*Byte 5: LSB

SMART attribute ID list

| ID (Hex) | Attribute Name |
|------------|------------------------------------|
| 9 (0x09) | Power-on hours |
| 12 (0x0C) | Power cycle count |
| 163 (0xA3) | Max. erase count |
| 164 (0xA4) | Avg. erase count |
| 166 (0xA6) | Total later bad block count |
| 167 (0xA7) | SSD Protect Mode (vendor specific) |
| 168 (0xA8) | SATA PHY Error Count |
| 175 (0xAF) | Bad Cluster Table Count |
| 192 (0xC0) | Unexpected Power Loss Count |
| 194 (0xC2) | Temperature |
| 241 (0xF1) | Total sectors of write |

7. Electrical Specifications

7.1 Operating Voltage

Table 7-1 lists the supply voltage for SM210-M280.

Table 7-1 Operating Range

| Item | Range |
|----------------|--------------------------|
| Supply Voltage | 3.3V ± 5% (3.135-3.465V) |

7.2 Power Consumption

Table 7-2 lists the power consumption for SM210-M280.

Table 7-2 Power Consumption

| Mode \ Capacity | 32 GB | 64 GB | 128 GB | 256 GB | 512 GB |
|-----------------|-------|-------|--------|--------|--------|
| Active (mA) | 315 | 320 | 455 | 700 | 975 |
| Idle (mA) | 150 | 155 | 155 | 150 | 155 |

Note:

*All values are typical and may vary depending on flash configurations or host system settings.

**Active power is an average power measurement performed using CrystalDiskMark with 128KB sequential read/write transfers.

8. Physical Characteristics

8.1 Single Side

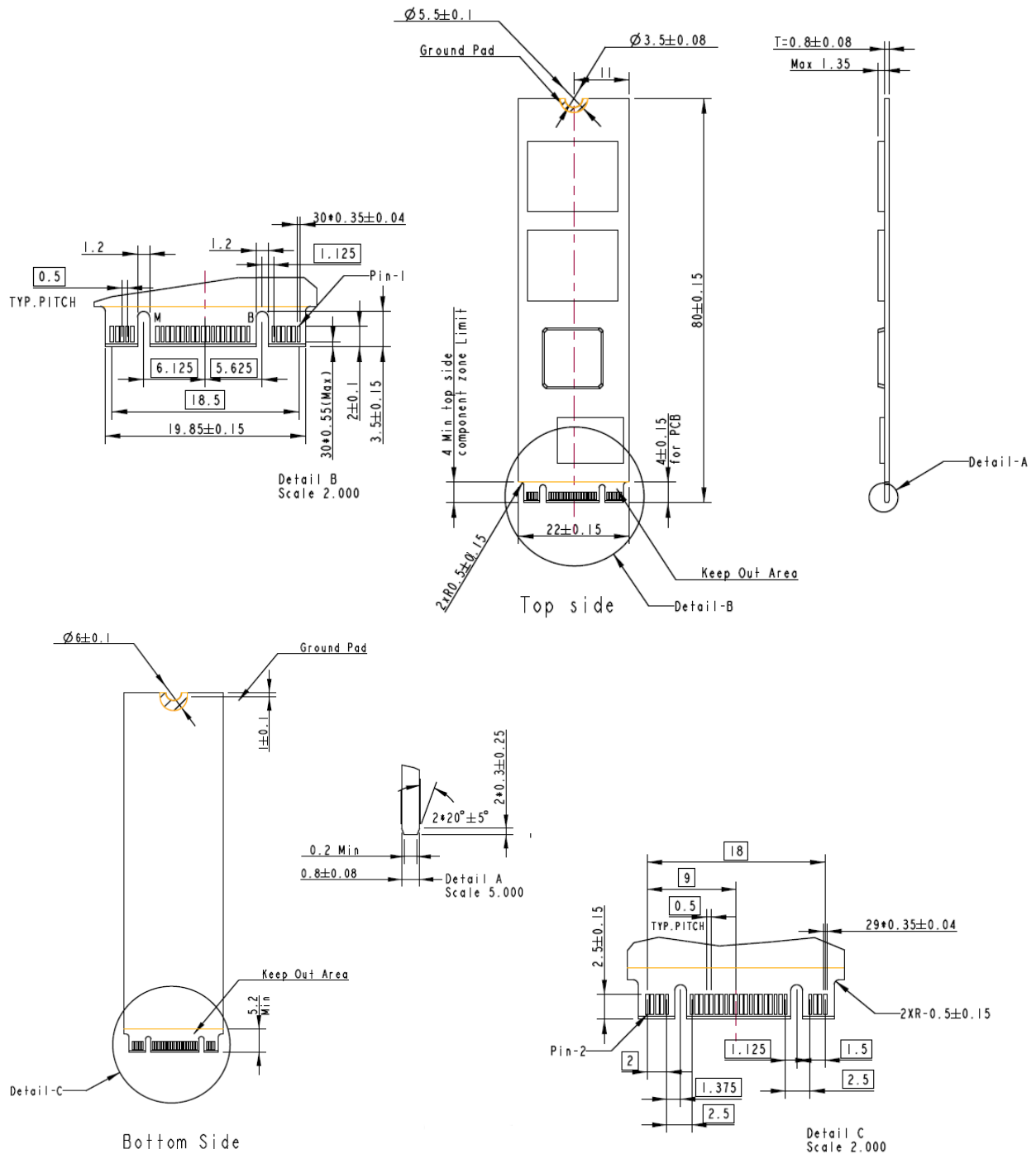

8.2 Double Side

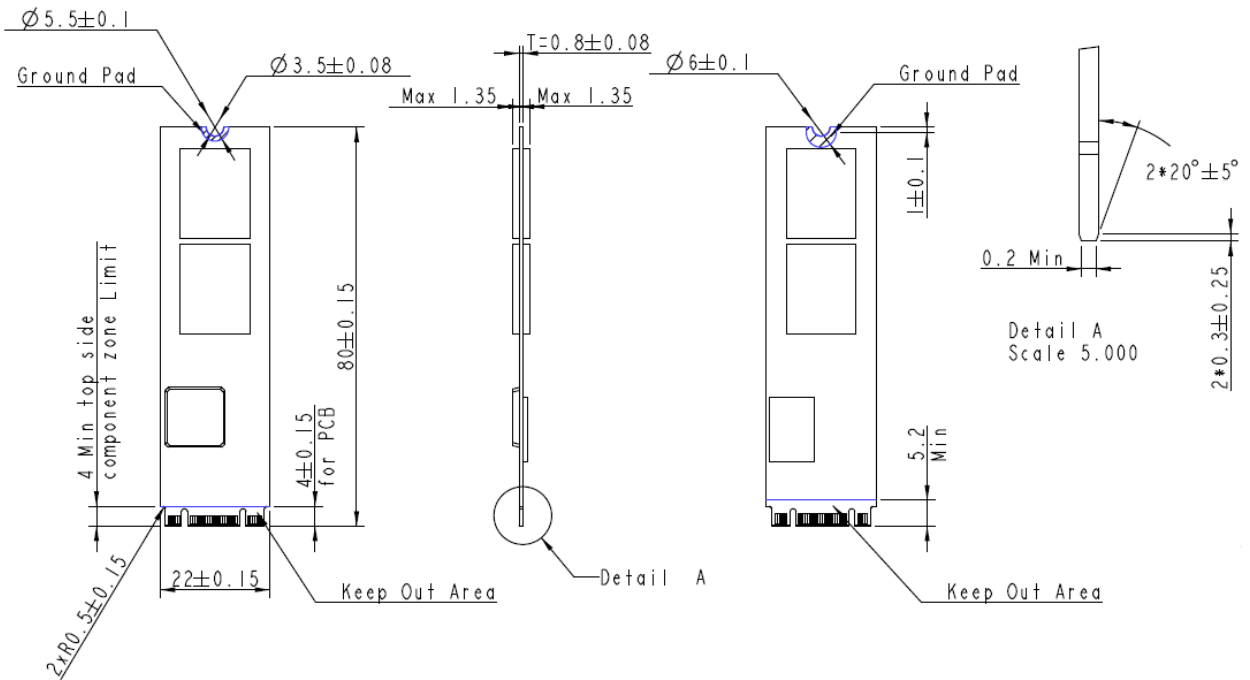

9. Product Ordering Information

9.1 Product Code Designations

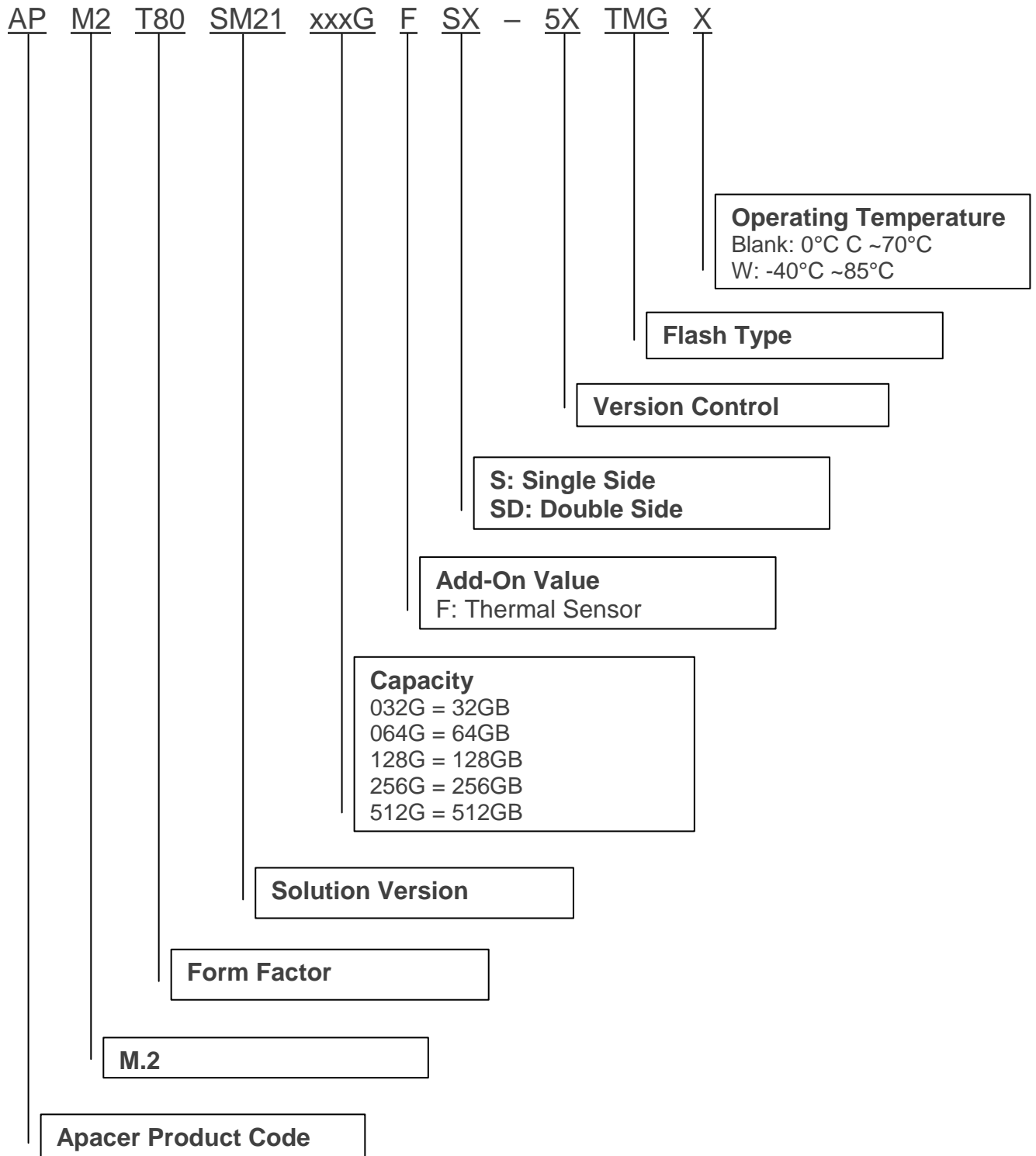

9.2 Valid Combinations

9.2.1 Standard Temperature

| Capacity | No DEVSLP | DEVSLP |
|----------|--------------------------|--------------------------|
| 32GB | APM2T80SM21032GTS-5ATMG | APM2T80SM21032GFS-5BTMG |
| 64GB | APM2T80SM21064GTS-5ATMG | APM2T80SM21064GFS-5BTMG |
| 128GB | APM2T80SM21128GTS-5ATMG | APM2T80SM21128GFS-5BTMG |
| 256GB | APM2T80SM21256GTS-5ATMG | APM2T80SM21256GFS-5BTMG |
| 512GB | APM2T80SM21512GTSD-5ATMG | APM2T80SM21512GFSD-5BTMG |

9.2.2 Extended Temperature

| Capacity | No DEVSLP | DEVSLP |
|----------|---------------------------|---------------------------|
| 32GB | APM2T80SM21032GTS-5ATMGW | APM2T80SM21032GFS-5BTMGW |
| 64GB | APM2T80SM21064GTS-5ATMGW | APM2T80SM21064GFS-5BTMGW |
| 128GB | APM2T80SM21128GTS-5ATMGW | APM2T80SM21128GFS-5BTMGW |
| 256GB | APM2T80SM21256GTS-5ATMGW | APM2T80SM21256GFS-5BTMGW |
| 512GB | APM2T80SM21512GTSD-5ATMGW | APM2T80SM21512GFSD-5BTMGW |

Note: Valid combinations are those products in mass production or will be in mass production. Consult your Apacer sales representative to confirm availability of valid combinations and to determine availability of new combinations.

Revision History

| Revision | Description | Date |
|----------|---|-----------|
| 1.0 | Official release | 5/10/2018 |
| 1.1 | Updated 3.3 Environmental Specifications and 3.5 Certification and Compliance | 5/11/2018 |
| 1.2 | <ul style="list-style-type: none">- Updated Endurance on Specifications Overview and 3.6 Endurance- Added Thermal Sensor to Reliability on Specifications Overview- Added 5. Reliability Features- Updated 9. Product Ordering Information by adding the code "F" which represents support of thermal sensor | 5/25/2018 |
| 1.3 | Updated 5.1 Thermal Sensor | 7/9/2018 |

Global Presence

Taiwan (Headquarters)

Apacer Technology Inc.

1F., No.32, Zhongcheng Rd., Tucheng Dist.,
New Taipei City 236, Taiwan R.O.C.
Tel: 886-2-2267-8000
Fax: 886-2-2267-2261
amtsales@apacer.com

U.S.A.

Apacer Memory America, Inc.

46732 Lakeview Blvd., Fremont, CA 94538
Tel: 1-408-518-8699
Fax: 1-510-249-9551
sa@apacerus.com

Japan

Apacer Technology Corp.

6F, Daiyontamachi Bldg., 2-17-12, Shibaura, Minato-Ku,
Tokyo, 108-0023, Japan
Tel: 81-3-5419-2668
Fax: 81-3-5419-0018
jpservices@apacer.com

Europe

Apacer Technology B.V.

Science Park Eindhoven 5051 5692 EB Son,
The Netherlands
Tel: 31-40-267-0000
Fax: 31-40-290-0686
sales@apacer.nl

China

Apacer Electronic (Shanghai) Co., Ltd

Room D, 22/FL, No.2, Lane 600, JieyunPlaza,
Tianshan RD, Shanghai, 200051, China
Tel: 86-21-6228-9939
Fax: 86-21-6228-9936
sales@apacer.com.cn

India

Apacer Technologies Pvt Ltd,

Unit No.201, "Brigade Corner", 7th Block
Jayanagar,
Yediyur Circle, Bangalore – 560082, India
Tel: 91-80-4152-9061
Fax: 91-80-4170-0215
sales_india@apacer.com