

RoHS Recast Compliant

Serial ATA Flash Drive

SU120 M.2 2280 Product Specifications

July 7, 2015

Version 1.1



Apacer Technology Inc.

1F, No.32, Zhongcheng Rd., Tucheng Dist., New Taipei City, Taiwan, R.O.C

Tel: +886-2-2267-8000 Fax: +886-2-2267-2261

www.apacer.com

Features:

- **Standard SATA Interface Compliance**
 - Serial ATA Revision 3.1 compliance
 - SATA 6.0 Gbps interface
 - ATA-8 command set
- **Capacities**
 - 8, 16, 32, 64, 128 GB
- **Performance***
 - Burst read/write: 600 MB/sec
 - Sustained read: up to 515 MB/sec
 - Sustained write: up to 180 MB/sec
- **Flash Management**
 - Built-in hardware ECC
 - Static/dynamic wear-leveling
 - Flash bad-block management
 - S.M.A.R.T.
 - Power Failure Management
 - ATA Secure Erase
 - TRIM
- **NAND Flash Type:** MLC
- **Firmware Version:** SLC-Lite
- **Endurance**
 - 8 GB: 72 TBW
 - 16 GB: 145 TBW
 - 32 GB: 290 TBW
 - 64 GB: 581 TBW
 - 128 GB: 1,163 TBW
- **Temperature ranges**
 - Operating:
 - Standard: 0°C to 70°C
 - Extended: -40°C to 85°C
 - Storage: -40°C to 85°C
- **Supply voltage**
 - 3.3 V ± 5%
- **Power consumption (typical)***
 - Active mode: 600 mA
 - Idle mode: 90 mA
- **Connector type**
 - 75-pin SATA-based M.2 module pinout
- **Form factor**
 - M.2 2280 form factor
 - Dimensions: 80.00 x 22.00 x 3.80, unit: mm
- **Shock & Vibration*****
 - Shock: 1500 G
 - Vibration: 15 G
- **MTBF:** >2,000,000 hours
- **RoHS Recast compliant (complies with 2011/65/EU standard)**
- **Device Sleep mode (optional)**

*Varies from capacities. The values for performances and power consumptions presented are typical and may vary depending on flash configurations or platform settings. The term idle refers to the standby state of the device.

**Non-operating

Table of Contents

1. General Description	3
2. Pin Assignments.....	3
3. Product Specifications.....	6
3.1 Capacity.....	6
3.2 Performance	6
3.3 Environmental Specifications	7
3.4 Mean Time Between Failures (MTBF)	7
3.5 Certification and Compliance	7
4. Flash Management	8
4.1 Error Correction/Detection.....	8
4.2 Bad Block Management	8
4.3 Wear Leveling.....	8
4.4 Power Failure Management	8
4.5 ATA Secure Erase.....	8
4.6 TRIM.....	9
4.7 SATA Power Management.....	9
4.8 SLC-Lite.....	9
4.9 Endurance	10
5. Software Interface	11
5.1 Command Set.....	11
5.2 S.M.A.R.T.	12
6. Electrical Specification	13
7. Physical Characteristics.....	14
8. Product Ordering Information.....	16

1. General Description

Apacer's SU120-M280 is the next generation modularized Solid State Drive (SSD) with the shape of all new M.2 form factor, aimed to be the more suitable for mobile and compact computers with standard width at only 22.00 mm. SU120-M280 appears in M.2 2280 mechanical dimensions and is believed to be the leading add-in storage solution for future host computing systems.

The M.2 SSD is designed with SATA-based connector pinouts, providing full compliance with the latest SATA Revision 3.2 interface specifications. Aside from SATA compliance, SU120-M280 delivers exceptional performance and power efficiency. On the other hand, the extreme thin and light form factor makes SU120-M280 the ideal choice for mobile computing systems, which appears to be the trend in near future.

Regarding reliability, SU120-M280 is built with a powerful SATA controller that supports on-the-module ECC as well as efficient wear leveling scheme. In terms of power efficiency, SU120-M280 is compliant with SATA 6.0 Gbps interface standard so that it can operate on SATA power management modes, which greatly save on power consumption.

2. Pin Assignments

This connector does not support hot plug capability. There are a total of 75 pins. 12 pin locations are used for mechanical key locations; this allows such a module to plug into both Key B and Key M connectors.

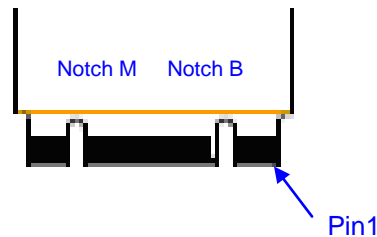

Pin	Type	Description
1	CONFIG_3	Ground (according to M.2 configurations for SSD-SATA definition)
2	3.3V	Supply Pin, 3.3V
3	GND	Ground
4	3.3V	Supply pin, 3.3V
5	No connect	No connect
6	Not available	No connect (used for other purposes)
7	Not available	No connect (used for other purposes)
8	Not available	No connect (used for other purposes)
9	No connect	No connect
10	DAS/DSS	Device Activity Signal/Disable Staggered Spin-up
11	No connect	No connect (used for other purposes)

M.2 2280 Flash Drive APM2T80P201xxxxAN-XTMX

12	(removed for key)	Mechanical notch B
13	(removed for key)	Mechanical notch B
14	(removed for key)	Mechanical notch B
15	(removed for key)	Mechanical notch B
16	(removed for key)	Mechanical notch B
17	(removed for key)	Mechanical notch B
18	(removed for key)	Mechanical notch B
19	(removed for key)	Mechanical notch B
20	Not available	No connect (used for other purposes)
21	CONFIG_0	Ground (according to M.2 configurations for SSD-SATA definition)
22	Not available	No connect (used for other purposes)
23	Not available	No connect (used for other purposes)
24	Not available	No connect (used for other purposes)
25	Not available	No connect (used for other purposes)
26	Not available	No connect (used for other purposes)
27	GND	Ground
28	Not available	No connect (used for other purposes)
29	PERn1	Not used
30	Not available	No connect (used for other purposes)
31	PERp1	Not used
32	Not available	No connect (used for other purposes)
33	GND	Ground
34	Not available	No connect (used for other purposes)
35	PETn1	Not used
36	Not available	No connect (used for other purposes)
37	PETp1	Not used
38	DEVSLP	Device Sleep, input. If driven high the host is informing the SSD to enter a low power state (optional)
39	GND	Ground
40	Not available	No connect (used for other purposes)
41	SATA-Rx+	Host receiver differential signal pair
42	Not available	No connect (used for other purposes)
43	SATA-Rx-	Host receiver differential signal pair
44	Not available	No connect (used for other purposes)
45	GND	Ground
46	Not available	No connect (used for other purposes)
47	SATA-Tx-	Host transmitter differential pair

M.2 2280 Flash Drive APM2T80P201xxxxAN-XTMX

48	Not available	No connect (used for other purposes)
49	SATA-Tx+	Host transmitter differential pair
50	PERST#	Not used
51	GND	Ground
52	CLKREQ#	Not used
53	REFCLKN	Not used
54	PEWAKE#	Not used
55	REFCLKP	Not used
56	MFG1	Manufacturing pin. Use determined by vendor (no connect on a host)
57	GND	Ground
58	MFG2	Manufacturing pin. Use determined by vendor (no connect on a host)
59	(removed for key)	Mechanical notch M
60	(removed for key)	Mechanical notch M
61	(removed for key)	Mechanical notch M
62	(removed for key)	Mechanical notch M
63	(removed for key)	Mechanical notch M
64	(removed for key)	Mechanical notch M
65	(removed for key)	Mechanical notch M
66	(removed for key)	Mechanical notch M
67	Not available	No connect (used for other purposes)
68	SUSCLK	Not used
69	CONFIG_1	Ground
70	3.3V	Supply pin, 3.3V
71	GND	Ground
72	3.3V	Supply pin, 3.3V
73	GND	Ground
74	3.3V	Supply pin, 3.3V
75	CONFIG_2	Ground

3. Product Specifications

3.1 Capacity

Capacity specification of SU120-M280 is available as shown in Table 3-1. It lists the specific capacity and the default numbers of heads, sectors and cylinders for each product line.

Table 3-1: Capacity specifications

Capacity	Total bytes*	Cylinders	Heads	Sectors	Max LBA
8 GB	8,012,390,400	15,525	16	63	15,649,200
16 GB	16,013,942,784	16,383	16	63	31,277,232
32 GB	32,017,047,552	16,383	16	63	62,533,296
64 GB	64,023,257,088	16,383	16	63	125,045,424
128 GB	128,035,676,160	16,383	16	63	250,069,680

*Display of total bytes varies from file systems, which means not all of the bytes can be used for storage.

**Notes: 1 GB = 1,000,000,000 bytes; 1 sector = 512 bytes.

LBA count addressed in the table above indicates total user storage capacity and will remain the same throughout the lifespan of the device. However, the total usable capacity of the SSD is most likely to be less than the total physical capacity because a small portion of the capacity is reserved for device maintenance usages.

3.2 Performance

Performances of SU120-M280 are listed below in table 3-2.

Table 3-2: Performance

Capacity	8 GB	16 GB	32 GB	64 GB	128 GB
Performance					
Sustained read (MB/s)	300	510	515	515	515
Sustained write (MB/s)	170	180	180	180	180

Note: Results were measured by CrystalDiskMark and may differ from various flash configurations or host system setting

3.3 Environmental Specifications

Environmental specification of SU120-M280 series follows MIL-STD-810 standards as shown in Table 3-3.

Table 3-3 SU120-M280 environmental specifications

Item	Specification
Operating temperature	0°C~70°C (standard) ; -40°C~85°C (extended)
Non-operating temperature	-40°C~85°C
Operating humidity	40°C, 90%RH
Non-operating humidity	40°C, 93%RH
Vibration (Non-operating)	Frequency/Displacement: 20Hz~80Hz/1.52mm Frequency/Acceleration: 80Hz~2000Hz/20G X, Y, Z axis/60mins
shock (Non-operating)	1500G, 0.5ms
Drop (Non-operating)	80cm free fall, 6 face of each unit
Bending (non-operating)	≥20N, hold 1min/5times
Torque (non-operating)	0.5N-m or ±2.5 deg, hold 1min/5times
ESD (Electrostatic)	Passed (at relative temp/humidity: 24°C, 49%RH)

3.4 Mean Time Between Failures (MTBF)

Mean Time Between Failures (MTBF) is predicted based on reliability data for the individual components in SU120-M280. The prediction result for SU120-M280 is more than 2,000,000 hours.

Notes about the MTBF:

The MTBF is predicated and calculated based on “Telcordia Technologies Special Report, SR-332, Issue 2” method.

3.5 Certification and Compliance

SU120-M280 complies with the following standards:

- CE: EN55022
- FCC :CISPR22
- BSMI 13438
- RoHS Recast

4. Flash Management

4.1 Error Correction/Detection

SU120-M280 implements a hardware ECC scheme, based on the BCH algorithm. It can detect and correct up to 72 bits error in 1K bytes.

4.2 Bad Block Management

Current production technology is unable to guarantee total reliability of NAND flash memory array. When a flash memory device leaves factory, it comes with a minimal number of initial bad blocks during production or out-of-factory as there is no currently known technology that produce flash chips free of bad blocks. In addition, bad blocks may develop during program/erase cycles. When host performs program/erase command on a block, bad block may appear in Status Register. Since bad blocks are inevitable, the solution is to keep them in control. Apacer flash devices are programmed with ECC, block mapping technique and S.M.A.R.T to reduce invalidity or error. Once bad blocks are detected, data in those blocks will be transferred to free blocks and error will be corrected by designated algorithms.

4.3 Wear Leveling

Flash memory devices differ from Hard Disk Drives (HDDs) in terms of how blocks are utilized. For HDDs, when a change is made to stored data, like erase or update, the controller mechanism on HDDs will perform overwrites on blocks. Unlike HDDs, flash blocks cannot be overwritten and each P/E cycle wears down the lifespan of blocks gradually. Repeatedly program/erase cycles performed on the same memory cells will eventually cause some blocks to age faster than others. This would bring flash storages to their end of service term sooner. Wear leveling is an important mechanism that level out the wearing of blocks so that the wearing-down of blocks can be almost evenly distributed. This will increase the lifespan of SSDs. Commonly used wear leveling types are Static and Dynamic.

4.4 Power Failure Management

Power Failure Management plays a crucial role when experiencing unstable power supply. Power disruption may occur when users are storing data into the SSD. In this urgent situation, the controller would run multiple write-to-flash cycles to store the metadata for later block rebuilding. This urgent operation requires about several milliseconds to get it done. At the next power up, the firmware will perform a status tracking to retrieve the mapping table and resume previously programmed NAND blocks to check if there is any incompleteness of transmission.

Note: The controller unit of this product model is designed with a DRAM as a write cache for improved performance and data efficiency. Though unlikely to happen in most cases, the data cached in the volatile DRAM might be potentially affected if a sudden power loss takes place before the cached data is flushed into non-volatile NAND flash memory.

4.5 ATA Secure Erase

ATA Secure Erase is an ATA disk purging command currently embedded in most of the storage drives. Defined in ATA specifications, (ATA) Secure Erase is part of Security Feature Set that allows storage drives to erase all user data areas. The erase process usually runs on the firmware level as most of the ATA-based storage media currently in the market are built-in with this command. ATA Secure Erase can securely wipe out the user data in the drive and protects it from malicious attack.

4.6 TRIM

TRIM, though in capital letters usually, is a memory computation command rather than an abbreviation. It is mainly a SATA command that enables the operating system to inform the SSD (Solid State Drive) which blocks of previously stored data are no longer valid, due to erases by the host or operating system, such as file deletions or disk formatting. Once notified, SSD will begin the discard of the invalid LBAs and retain more space for itself, in fact, the discarded is no longer recoverable.

When an LBA is replaced by the operating system, as with overwrite of a file, the SSD is informed that the originally occupied LBA is determined as no longer in use or invalid. The SSD will not save those blocks in garbage collected sectors. Noticeably, a file deletion command by host or operating system never actually erases the actual content, rather, just the file is marked as deleted. This issue is even specifically noticeable for flash based memory devices, such as SSDs. In fact, an SSD will keep garbage collecting the invalid, previously occupied LBAs, if it is not informed that these LBAs can be erased. Thus, the SSD would experience a significant performance downfall.

4.7 SATA Power Management

By complying with SATA 6.0 Gb/s specifications, the SSD supports the following SATA power saving modes:

- ACTIVE: PHY ready, full power, Tx & Rx operational
- PARTIAL: Reduces power, resumes in under 10 μ s (microseconds)
- SLUMBER: Reduces power, resumes in under 10 ms (milliseconds)
- HIPM: Host-Initiated Power Management
- DIPM: Device-Initiated Power Management
- Device Sleep (DevSleep or DEVSLP): PHY powered down; power consumption \leq 5 mW; host assertion time \leq 10 ms; exit timeout from this state \leq 20 ms (unless specified otherwise in SATA Identify Device Log).

Note:

1. The behaviors of power management features would depend on host/device settings.
2. Device Sleep mode is optional, depending on product ordering selections.

4.8 SLC-Lite

To achieve SLC-like performance and endurance, cell distribution management for MLC is necessary in order to greatly adjust the voltage delta and charge sensing. By programming only the least significant bit (LSB), the cell distribution behaves almost identical to that of SLC flash. This highly improves the precision of delta and the threshold voltage of each cell. Thus, the MLC performance and endurance, especially in P/E cycles, will be escalating by multiplies, to the level almost on par with SLC. In this case, users would get all the benefits of both the quality and the cost.

4.9 Endurance

The endurance of a storage device is predicted by TeraBytes Written based on several factors related to usage, such as the amount of data written into the drive, block management conditions, and daily workload for the drive. Thus, key factors, such as Write Amplifications and the number of P/E cycles, can influence the lifespan of the drive.

Capacity	TeraBytes Written
8 GB	72
16 GB	145
32 GB	290
64 GB	581
128 GB	1,163

Notes:

- The measurement assumes the data written to the SSD for test is under a typical and constant rate.
- The measurement follows the standard metric: 1 TB (Terabyte) = 1000 GB.
- This estimation complies with JEDEC JESD-219, enterprise endurance workload of random data with payload size distribution.

5. Software Interface

5.1 Command Set

This section defines the software requirements and the format of the commands the host sends to SU120-M280. Commands are issued to SU120-M280 by loading the required registers in the command block with the supplied parameters, and then writing the command code to the Command register.

Table 6-1: Command set

Command	Code	Command	Code
Data Set Management	06h	CHECK POWER MODE	98h
Recalibrate	10h-1Fh	SLEEP	99h
Read Sectors	20h	SMART	B0h
Read Sectors without Retry	21h	DEVICE CONFIGURATION	B1h
Read Sectors EXT	24h	Read Multiple	C4h
Read DMA EXT	25h	Write Multiple	C5h
Read Native Max Address EXT	27h	Set Multiple Mode	C6h
Read Multiple EXT	29h	Read DMA	C8h
Read Log EXT	2Fh	Read DMA without Retry	C9h
Write Sectors	30h	Write DMA	CAh
Write Sectors without Retry	31h	Write DMA without Retry	CBh
Write Sectors EXT	34h	Write Multiple FUA EXT	CEh
Write DMA EXT	35h	Standby Immediate	E0h
Set Native Max Address EXT	37h	Idle Immediate	E1h
CFA WRITE SECTORS WITHOUT ERASE	38h	Standby	E2h
Write Multiple EXT	39h	IDLE	E3h
Write DMA FUA EXT	3Dh	Read Buffer	E4h
Write Long EXT	3Fh	Check Power Mode	E5h
Read Verify Sectors	40h	Sleep	E6h
Read Verify Sectors without Retry	41h	Flush Cache	E7h
Read Verify Sectors EXT	42h	Write Buffer	E8h
WRITE UNCORRECTABLE EXT	45h	Flush Cache EXT	EAh
Read FPDMA Queued	60h	Identify Device	ECh
Write FPDMA Queued	61h	Set Features	EFh
Seek	70h-71h	Security Set Password	F1h
Execute Device Diagnostic	90h	Security Unlock	F2h
Initialize Device Parameters	91h	Security Erase Prepare	F3h
Download Microcode	92h	Security Erase Unit	F4h

M.2 2280 Flash Drive APM2T80P201xxxxAN-XTMX



DOWNLOAD MICROCODE DMA	93h	Security Freeze Lock	F5h
STANDBY IMMEDIATE	94h	Security Disable Password	F6h
IDLE IMMEDIATE	95h	Read Native Max Address	F8
STANDBY	96h	Set Max Address	F9
IDLE	97h		

5.2 S.M.A.R.T.

SMART, an acronym for Self-Monitoring, Analysis and Reporting Technology, is an open standard that allows a hard disk drive to automatically detect its health and report potential failures. When a failure is recorded by SMART, users can choose to replace the drive to prevent unexpected outage or data loss. Moreover, SMART can inform users of impending failures while there is still time to perform proactive actions, such as copy data to another device

6. Electrical Specification

Table 6-1: Operating range

Ambient Temperature	0°C~70°C (standard) -40°C~85°C (extended)
Supply Voltage	3.3V±5% (3.135-3.465V)

Table 6-2: Power consumption (typical)

Modes \ Capacity	8 GB	16 GB	32 GB	64 GB	128 GB
Active (mA)	355	470	445	535	600
Idle (mA)	85	85	90	90	90

Note: Results may differ from various flash configurations or host system setting

7. Physical Characteristics

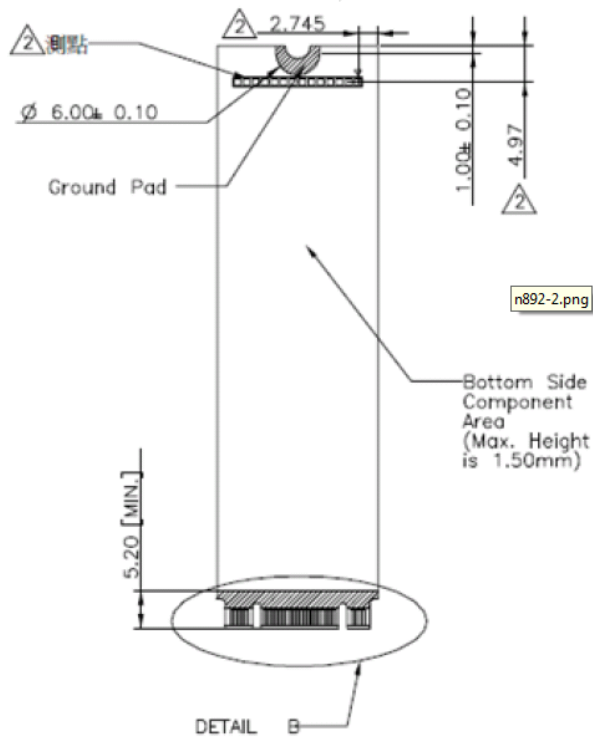
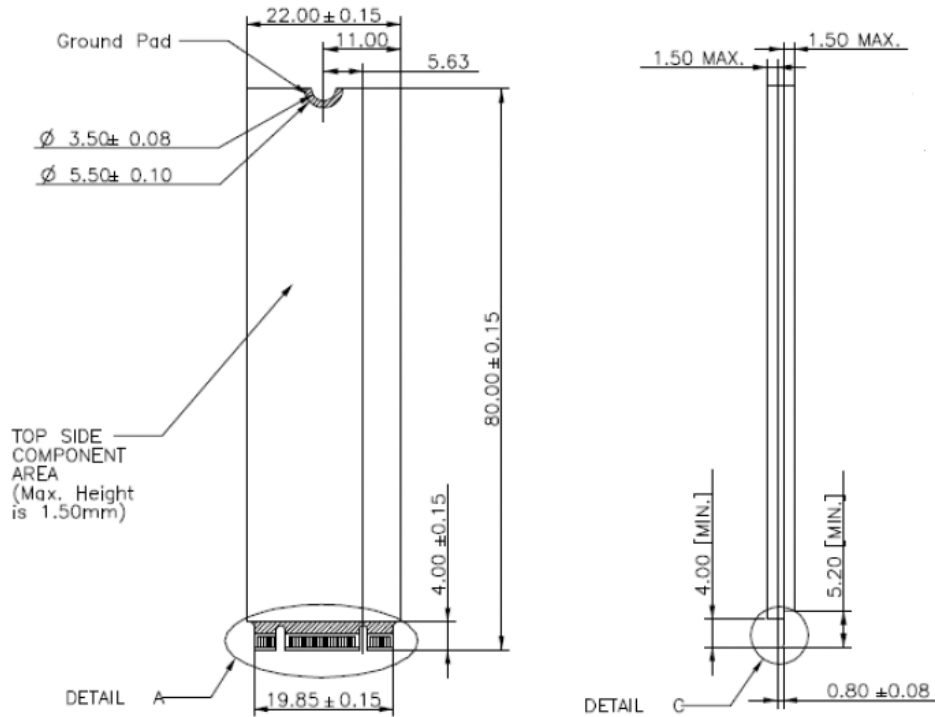

Unit: mm
Tolerance: ± 0.2 mm

M.2 2280 Flash Drive
 APM2T80P201xxxxAN-XTMX

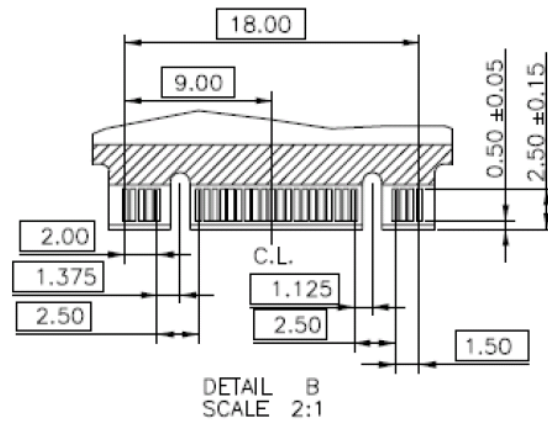
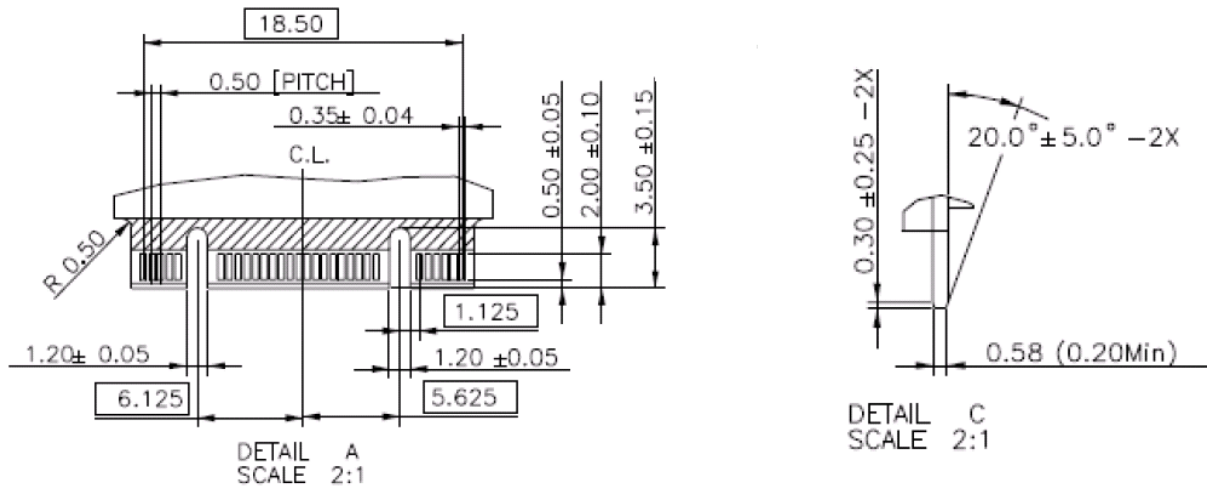

Unit: mm
 Tolerance: ±0.2 mm

8. Product Ordering Information

8.1 Product Code Designations

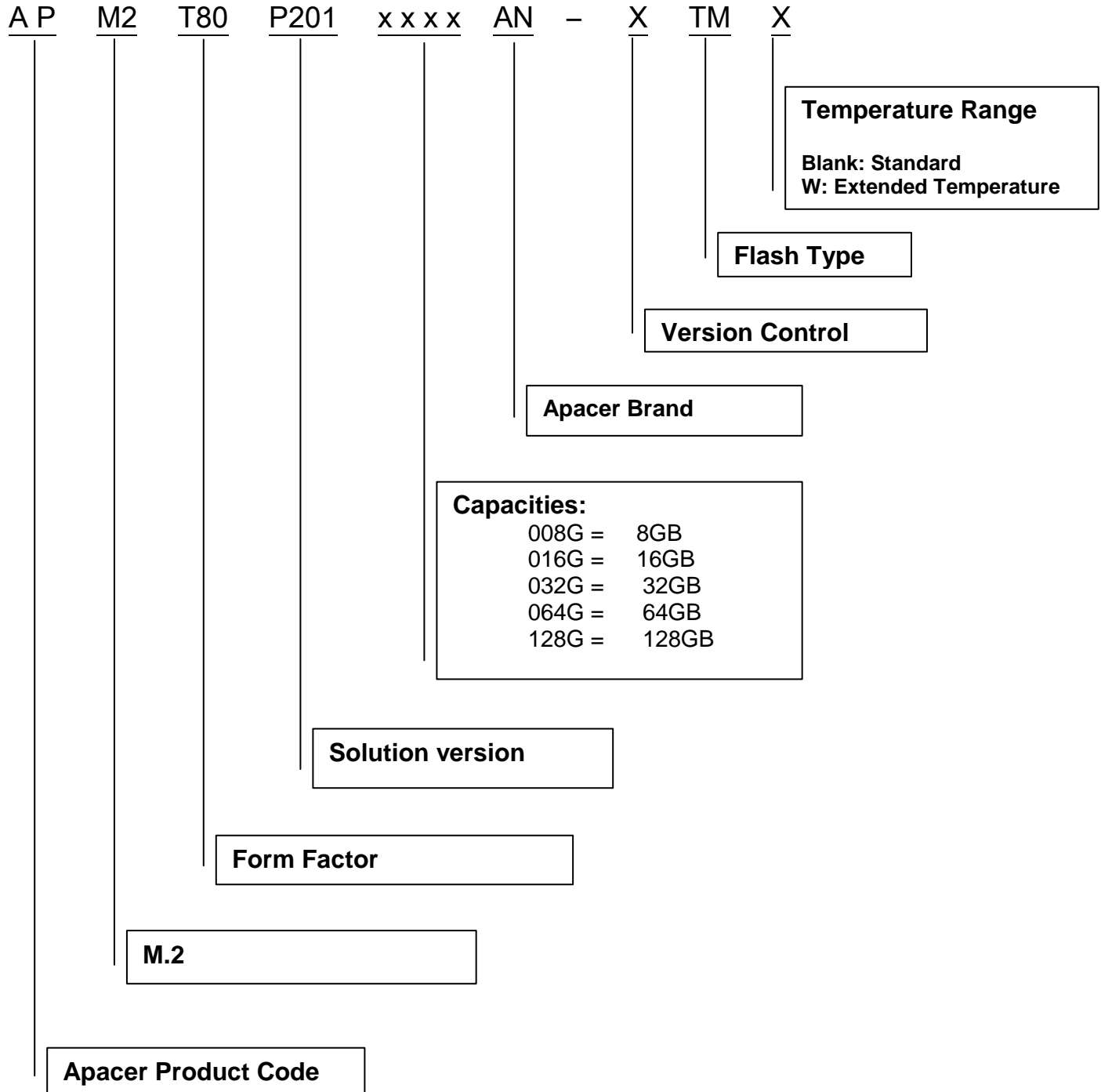

8.2 Valid Combinations

8.2.1 Standard Temperature

Capacity	No DEVSLP	DEVSLP
8GB	APM2T80P201008GAN-LTM	APM2T80P201008GAN-MTM
16GB	APM2T80P201016GAN-LTM	APM2T80P201016GAN-MTM
32GB	APM2T80P201032GAN-LTM	APM2T80P201032GAN-MTM
64GB	APM2T80P201064GAN-LTM	APM2T80P201064GAN-MTM
128GB	APM2T80P201128GAN-LTM	APM2T80P201128GAN-MTM

8.2.2 Extended Temperature

Capacity	No DEVSLP	DEVSLP
8GB	APM2T80P201008GAN-LTMW	APM2T80P201008GAN-MTMW
16GB	APM2T80P201016GAN-LTMW	APM2T80P201016GAN-MTMW
32GB	APM2T80P201032GAN-LTMW	APM2T80P201032GAN-MTMW
64GB	APM2T80P201064GAN-LTMW	APM2T80P201064GAN-MTMW
128GB	APM2T80P201128GAN-LTMW	APM2T80P201128GAN-MTMW

Note: Valid combinations are those products in mass production or will be in mass production. Consult your Apacer sales representative to confirm availability of valid combinations and to determine availability of new combinations.

Revision History

Revision	Date	Description	Remark
1.0	06/08/2015	First release	
1.1	07/07/2015	Added endurance information	

Global Presence

Taiwan (Headquarters)	Apacer Technology Inc. 1F., No.32, Zhongcheng Rd., Tucheng Dist., New Taipei City 236, Taiwan R.O.C. Tel: 886-2-2267-8000 Fax: 886-2-2267-2261 amtsales@apacer.com
U.S.A.	Apacer Memory America, Inc. 386 Fairview Way, Suite102, Milpitas, CA 95035 Tel: 1-408-518-8699 Fax: 1-408-935-9611 sa@apacerus.com
Japan	Apacer Technology Corp. 5F, Matsura Bldg., Shiba, Minato-Ku Tokyo, 105-0014, Japan Tel: 81-3-5419-2668 Fax: 81-3-5419-0018 jpservices@apacer.com
Europe	Apacer Technology B.V. Science Park Eindhoven 5051 5692 EB Son, The Netherlands Tel: 31-40-267-0000 Fax: 31-40-267-0000#6199 sales@apacer.nl
China	Apacer Electronic (Shanghai) Co., Ltd Room D,22/FL,No2,Lane600,JieyunPlaza, Tianshan RD,Shanghai,200051,China Tel: 86-21-6228-9939 Fax: 86-21-6228-9936 sales@apacer.com.cn
India	Apacer Technologies Pvt Ltd, # 535, 1st Floor, 8th cross, JP Nagar 3rd Phase, Bangalore – 560078, India Tel: 91-80-4152-9061 sales_india@apacer.com