

RoHS Compliant

Serial ATA Flash Drive

SM140-M280 Product Specifications (Toshiba 15nm)

March 14, 2016

Version 1.1



Apacer Technology Inc.

1F, No.32, Zhongcheng Rd., Tucheng Dist., New Taipei City, Taiwan, R.O.C

Tel: +886-2-2267-8000

Fax: +886-2-2267-2261

www.apacer.com

M.2 2280 Flash Drive

APM2T80SM14xxxGAN-XTM



Features:

- **Compliance with SATA Revision 3.1**
 - SATA 6.0 Gbps interface
 - Backward compatible with SATA 1.5/3.0 Gbps interfaces
 - ATA command set
- **Capacity**
 - Single side: 64, 128, 256 GB
 - Double side: 512 GB
- **Performance***
 - Interface burst read/write: 600 MB/sec
 - Sustained read: up to 520 MB/sec
 - Sustained write: up to 380 MB/sec
- **Flash Management**
 - Built-in hardware ECC
 - Wear leveling
 - Bad block management
 - S.M.A.R.T.
 - Power failure management
 - TRIM
- **NAND Flash Type: MLC**
- **MTBF: >1,000,000 hours**
- **Endurance**
 - 64GB: 107 TBW
 - 128GB: 215 TBW
 - 256GB: 431 TBW
 - 512GB: 863 TBW
- **Temperature Range**
 - Operating: 0°C to 70°C
 - Storage: -40°C to 100°C
- **Supply Voltage**
 - 3.3 V \pm 5%
- **Power Consumption***
 - Active mode: 1,126 mA
 - Idle mode: 130 mA
- **Connector Type**
 - 75-pin SATA-based M.2 module pinout
- **Form Factor**
 - M.2 2280 form factor
 - Dimensions:
 - Single side: 80.00 x 22.00 x 2.30, unit: mm
 - Double side: 80.00 x 22.00 x 3.80, unit: mm
- **Device Sleep Mode**
- **RoHS Compliant**

*Varies from capacities. The values addressed here are typical and may vary depending on host system settings.

Table of Contents

1. Product Description	3
1.1 Introduction	3
1.2 Capacity Specifications	3
1.3 Performance	3
1.4 Pin Assignments	4
2. Software Interface	6
2.1 Command Set	6
2.2 S.M.A.R.T.	7
3. Flash Management	8
3.1 Error Correction/Detection	8
3.2 Bad Block Management	8
3.3 Wear Leveling	8
3.4 Power Failure Management	8
3.5 TRIM	8
3.6 Secure Erase	8
3.7 Endurance	9
4. Environment Specifications	10
4.1 Environmental	10
4.2 Mean Time Between Failures (MTBF)	10
4.3 Certification and Compliance	10
5. Electrical Characteristics	11
5.1 Operating Voltage	11
5.2 Power Consumption	11
6. Physical Characteristics	12
7. Product Ordering Information	14
7.1 Product Code Designations	14
7.2 Valid Combinations	15

1. Product Description

1.1 Introduction

Apacer SM140-M280 (M.2 2280) is the next generation modularized Solid State Drive (SSD) with the shape of all new M.2 form factor, aimed to be the more suitable for mobile and compact computers with standard width at only 22.00 mm. SM140-M280 appears in M.2 2280 mechanical dimensions and is believed to be the leading add-in storage solution for future host computing systems.

The M.2 SSD is designed with SATA-based connector pinouts, providing full compliance with the latest SATA Revision 3.1 interface specifications. Aside from SATA compliance, SM140-M280 delivers exceptional performance and power efficiency. On the other hand, the extreme thin and light form factor makes SM140-M280 the ideal choice for mobile computing systems, which appears to be the trend in near future.

Regarding reliability, SM140-M280 is built with a powerful SATA controller that supports on-the-module ECC as well as efficient wear leveling scheme. In terms of power efficiency, SM140-M280 is compliant with SATA 6.0 Gbps interface standard so that it can operate on SATA power management modes, which greatly save on power consumption.

1.2 Capacity Specifications

Table 1-1 Capacity Specifications

Capacity	Total Bytes	Cylinders	Heads	Sectors	Max LBA
64 GB	64,023,257,088	16,383	16	63	125,045,424
128 GB	128,035,676,160	16,383	16	63	250,069,680
256 GB	256,060,514,304	16,383	16	63	500,118,192
512 GB	512,110,190,592	16,383	16	63	1,000,215,216

*Display of total bytes varies from file systems.

**Cylinders, heads or sectors are not applicable for these capacities. Only LBA addressing applies.

LBA count addressed in the table above indicates total user storage capacity and will remain the same throughout the lifespan of the device. However, the total usable capacity of the SSD is most likely to be less than the total physical capacity because a small portion of the capacity is reserved for device maintenance usages.

1.3 Performance

Performance of SM140-M280 is shown in Table 1-2.

Table 1-2 Performance Specifications

Capacity Performance	64 GB	128 GB	256 GB	512 GB
Sustained Read (MB/s)	520	520	520	520
Sustained Write (MB/s)	100	200	380	380

Note: Performance varies from flash configurations or host system settings.

1.4 Pin Assignments

This connector does not support hot plug capability. There are a total of 75 pins. 12 pin locations are used for mechanical key locations; this allows such a module to plug into both Key B and Key M connectors.

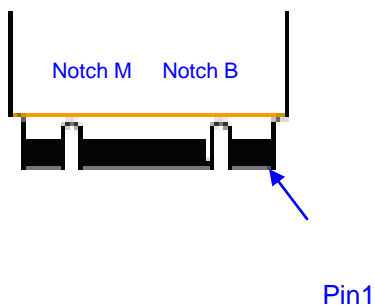

Table 1-3 Pin Assignments

Pin	Type	Description
1	CONFIG_3	Ground (according to M.2 configurations for SSD-SATA definition)
2	3.3V	Supply Pin, 3.3V
3	GND	Ground
4	3.3V	Supply pin, 3.3V
5	N/C	No connect
6	N/C	No connect
7	N/C	No connect
8	N/C	No connect
9	N/C or GND	No connect
10	DAS/DSS	Device Activity Signal/Disable Staggered Spin-up
11	N/C	No connect
12	(removed for key)	Mechanical notch B
13	(removed for key)	Mechanical notch B
14	(removed for key)	Mechanical notch B
15	(removed for key)	Mechanical notch B
16	(removed for key)	Mechanical notch B
17	(removed for key)	Mechanical notch B
18	(removed for key)	Mechanical notch B
19	(removed for key)	Mechanical notch B
20	N/C	No connect (used for other purposes)
21	CONFIG_0	Ground (according to M.2 configurations for SSD-SATA definition)
22	N/C	No connect
23	N/C	No connect
24	N/C	No connect
25	N/C	No connect
26	N/C	No connect
27	GND	Ground
28	N/C	No connect
29	N/C	Not used
30	N/C	No connect
31	N/C	No connect
32	N/C	No connect
33	GND	Ground
34	N/C	No connect
35	N/C	No connect
36	N/C	No connect

M.2 2280 Flash Drive APM2T80SM14xxxGAN-XTM



Table 1-3 Pin Assignments

Pin	Type	Description
37	N/C	No connect
38	DEVSLP	Device Sleep, input. If driven high the host is informing the SSD to enter a low power state
39	GND	Ground
40	N/C	No connect
41	SATA-Rx+	Host receiver differential signal pair
42	N/C	No connect
43	SATA-Rx-	Host receiver differential signal pair
44	N/C	No connect
45	GND	Ground
46	N/C	No connect
47	SATA-Tx-	Host transmitter differential pair
48	N/C	No connect
49	SATA-Tx+	Host transmitter differential pair
50	N/C	No connect
51	GND	Ground
52	N/C	No connect
53	N/C	No connect
54	N/C	No connect
55	N/C	No connect
56	MFG1	Manufacturing pin. Use determined by vendor (no connect on a host)
57	GND	Ground
58	MFG2	Manufacturing pin. Use determined by vendor (no connect on a host)
59	(removed for key)	Mechanical notch M
60	(removed for key)	Mechanical notch M
61	(removed for key)	Mechanical notch M
62	(removed for key)	Mechanical notch M
63	(removed for key)	Mechanical notch M
64	(removed for key)	Mechanical notch M
65	(removed for key)	Mechanical notch M
66	(removed for key)	Mechanical notch M
67	N/C	No connect
68	SUSCLK	Not used
69	CONFIG_1	Ground
70	3.3V	Supply pin, 3.3V
71	GND	Ground
72	3.3V	Supply pin, 3.3V
73	GND	Ground
74	3.3V	Supply pin, 3.3V
75	CONFIG_2	Ground

2. Software Interface

2.1 Command Set

Table 2-1 summarizes the ATA commands supported by SM140-M280.

Table 2-1 Command Set

Code	Command	Code	Command
00h	NOP	60h	Read FPDMA Queued
06h	Data Set management	61h	Write FPDMA Queued
10h	Recalibrate	70h	Seek
20h	Read Sectors	90h	Execute Device Diagnostic
21h	Read Sectors without Retry	91h	Initialize Device Parameters
24h	Read Sectors EXT	92h	Download Microcode
25h	Read DMA EXT	93h	Download Microcode DMA
27h	Read Native max Address EXT	B0h	SMART
29h	Read Multiple EXT	B0h/D0h	SMART READ DATA
2Fh	Read Log EXT	B0h/D1h	SMART READ DATA ATTRIBUTE THRESHOLD
30h	Write Sectors	B0h/D2h	SMART ENABLE/DISABLE ATTRIBUTE AUTOSAVE
31h	Write Sectors without Retry	B0h/D3h	SMART SAVE ATTRIBUTE VALUES
34h	Write Sectors EXT	B0h/D4h	SMART EXECUTE OFF-LINE IMMEDIATR
35h	Write DMA EXT	B0h/D5h	SMART READ LOG
37h	Set Native Max Address EXT	B0h/D6h	SMART WRITE LOG
39h	Write Multiple EXT	B0h/D8h	SMART ENABLE OPERATIONS
3Dh	Write DMA FUA EXT	B0h/D9h	SMART DISABLE OPERATIONS
3Fh	Write Long EXT	B0h/DAh	SMART RETURN STATUS
40h	Read Verify Sectors	B0h/DBh	SMART ENABLE/DISABLE AUTOMATIC OFF-LINE
41h	Read Verify Sectors without Retry	B1h	DEVICE CONFIGURATION OVERLAY
42h	Read Verify Sectors EXT	B1h/C0h	DEVICE CONFIGURATION RESTORE
45h	Write Uncorrectable EXT	B1h/C1h	DEVICE CONFIGURATION FREEZE LOCK
47h	Read Log DMA EXT	B1h/C2h	DEVICE CONFIGURATION IDENTIFY
57h	Write Log DMA EXT	B1h/C3h	DEVICE CONFIGURATION SET
B1h/C4h	DEVICE CONFIGURATION IDENTIFY DMA	ECh	Identify Device
B1h/C5h	DEVICE CONFIGURATION DMA	EFh	Set Features
C4h	Read Multiple	EFh/02h	Enable 8-bit PIO transfer mode
C5h	Write Multiple	EFh/03h	Set transfer mode based on value in Count field
C6h	Set Multiple Mode	EFh/05h	Enable advanced power management
C8h	Read DMA	EFh/10h	Enable use or Serial ATA feature

M.2 2280 Flash Drive
APM2T80SM14xxxGAN-XTM



Code	Command	Code	Command
C9h	Read DMA without Retry	EFh/10h/02h	Enable DMA Setup FIS Auto-Active optimization
CAh	Write DMA	EFh/10h/03h	Enable Device-initiated interface power state(DIPM) transitions
CBh	Write DMA without Retry	EFh/10h/06h	Enable Software Setting Preservation(SSP)
CEh	Write Multiple FUA EXT	EFh/10h/07h	Enable Device Automatic Partial to Slumber transitions
E0h	Standby Immediate	EFh/10h/09h	Enable Device Sleep
E1h	Idle Immediate	EFh/55H	Disable read look-ahead feature
E2h	Standby	EFh/66h	Disable reverting to power-on defaults
E3h	Idle	EFh/82h	Disable write cache
E4h	Read Buffer	EFh/85h	Disable advanced power management
E5h	Check Power Mode	EFh/90h	Disable use of Serial ATA feature set
E6h	Sleep	EFh/90h/02h	Disable DMA Setup FIS Auto-Activate optimization
E7h	Flush Cache	EFh/90h/03h	Disable Device-initiated interface power state(DIPM) transitions
E8h	Write Buffer	EFh/90h/06h	Disable Software Setting Preservation(SSP)
E9h	Read Buffer DMA	EFh/90h/07h	Disable Device Automatic Partial to Slumber transitions
EAh	Flush Cache EXT	EFh/90h/09h	Disable Device Sleep
EBh	Write Buffer DMA	EFh/AAh	Enable read look-ahead feature
EFh/CCh	Enable reverting to power-on defaults	F4h	Security Erase Unit
F1h	Security Set Password	F5h	Security Freeze Lock
F2h	Security Unlock	F6h	Security Disable Password
F3h	Security Erase Prepare	F8h	Read Native Max Address

Note. Security command will only be workable when device runs in non-OPAL compliant mode.

2.2 S.M.A.R.T.

SMART, an acronym for Self-Monitoring, Analysis and Reporting Technology, is an open standard that allows a hard disk drive to automatically detect its health and report potential failures. When a failure is recorded by SMART, users can choose to replace the drive to prevent unexpected outage or data loss. Moreover, SMART can inform users of impending failures while there is still time to perform proactive actions, such as copy data to another device.

3. Flash Management

3.1 Error Correction/Detection

Flash memory cells will deteriorate with use, which might generate random bit errors in the stored data. Thus, this M.2 2280 SSD module applies the BCH ECC Algorithm, which can detect and correct errors occur during Read process, ensure data been read correctly, as well as protect data from corruption. This device can correct up to 72bit/1K data.

3.2 Bad Block Management

Bad blocks are blocks that include one or more invalid bits, and their reliability is not guaranteed. Blocks that are identified and marked as bad by the manufacturer are referred to as “Initial Bad Blocks”. Bad blocks that are developed during the lifespan of the flash are named “Later Bad Blocks”. Apacer implements an efficient bad block management algorithm to detect the factory-produced bad blocks and manages any bad blocks that appear with use. This practice further prevents data being stored into bad blocks and improves the data reliability.

3.3 Wear Leveling

NAND Flash devices can only undergo a limited number of program/erase cycles, and in most cases, the flash media are not used evenly. If some areas get updated more frequently than others, the lifetime of the device would be reduced significantly. Thus, Wear Leveling technique is applied to extend the lifespan of NAND Flash by evenly distributing write and erase cycles across the media.

Apacer provides advanced Wear Leveling algorithm, which can efficiently spread out the flash usage through the whole flash media area. Moreover, by implementing both dynamic and static Wear Leveling algorithms, the life expectancy of the NAND Flash is greatly improved.

3.4 Power Failure Management

Power Failure Management plays a crucial role when experiencing unstable power supply. Power disruption may occur when users are storing data into the SSD. In this urgent situation, the controller would run multiple flush cycles to store the metadata for later block rebuilding. This urgent operation requires about several milliseconds to get it done. At the next power up, the firmware will perform a status tracking to retrieve the mapping table and resume previously programmed NAND blocks to check if there is any incompleteness of transmission.

3.5 TRIM

TRIM is a feature which helps improve the read/write performance and speed of solid-state drives (SSD). Unlike hard disk drives (HDD), SSDs are not able to overwrite existing data, so the available space gradually becomes smaller with each use. With the TRIM command, the operating system can inform the SSD which blocks of data are no longer in use and can be removed permanently. Thus, the SSD will perform the erase action, which prevents unused data from occupying blocks all the time.

3.6 Secure Erase

Secure Erase is a standard ATA command and will write all “0xFF” to fully wipe all the data on hard drives and SSDs. When this command is issued, the SSD controller will empty its storage blocks and return to its factory default settings.

Note: Secure erase command belongs to ATA security command.

3.7 Endurance

The endurance of a storage device is predicted by Tera Bytes Written based on several factors related to usage, such as the amount of data written into the drive, block management conditions, and daily workload for the drive. Thus, key factors, such as Write Amplifications and the number of P/E cycles, can influence the lifespan of the drive.

Capacity	Tera Bytes Written
64 GB	107
128 GB	215
256 GB	431
512 GB	863

Notes:

- The measurement assumes the data written to the SSD for test is under a typical and constant rate.
- The measurement follows the standard metric: 1 TB (Terabyte) = 1,000 GB.
- This estimation complies with JEDEC JESD-219, enterprise endurance workload of random data with payload size distribution.

4. Environment Specifications

4.1 Environmental

Table 4-1 Environmental Specifications

Environment	Specifications
Temperature	0°C to 70°C (Operating)
	-40°C to 100°C (in storage)
Shock	1500G, 0.5ms
Vibration	20Hz~80Hz/1.52mm (frequency/displacement) 80Hz~2000Hz/20G (frequency/displacement) X, Y, Z axis/60mins each
Drop	80cm free fall, 6 face of each
Bending	≥20N, hold 1min/5times
Torque	0.5N-m or 5deg, hold 5min/5times
ESD	Pass

Note: Shock and Vibration specifications are subject to change without notice.

4.2 Mean Time Between Failures (MTBF)

MTBF, an acronym for Mean Time Between Failures, is a measure of a device's reliability. Its value represents the average time between a repair and the next failure. The measure is typically in units of hours. The higher the MTBF value, the higher the reliability of the device. The predicted result of this M.2 2280 device is higher than 1,000,000 hours.

4.3 Certification and Compliance

SM140-M280 complies with the following standards:

- SATA Revision 3.1
- RoHS
- ATA/ATAPI
- FCC
- CE
- BSMI

5. Electrical Characteristics

5.1 Operating Voltage

Table 5-1 lists the supply voltage for SM140-M280.

Table 5-1 Operating Voltage

Parameter	Condition
Supply voltage	3.3V ± 5%

5.2 Power Consumption

Table 5-2 lists the power consumption for SM140-M280.

Table 5-2 Power Consumption (typical)

Mode \ Capacity	64 GB	128 GB	256 GB	512 GB
Active (mA)	640	730	1,100	1,126
Idle (mA)	130	130	130	130

Note: Power consumptions may vary depending on host system settings.

6. Physical Characteristics

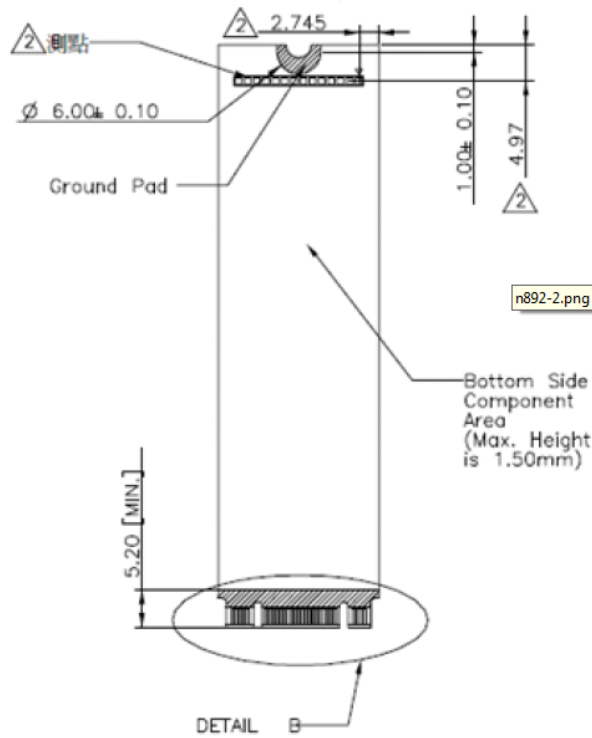
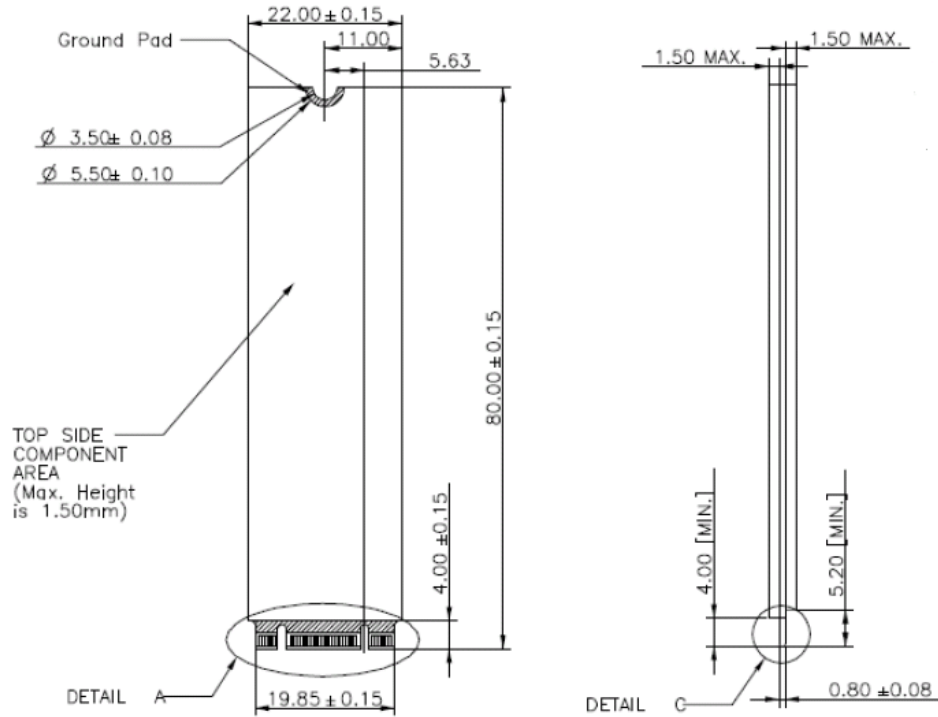

Unit: mm
 Tolerance: ±0.2 mm

M.2 2280 Flash Drive
APM2T80SM14xxxGAN-XTM

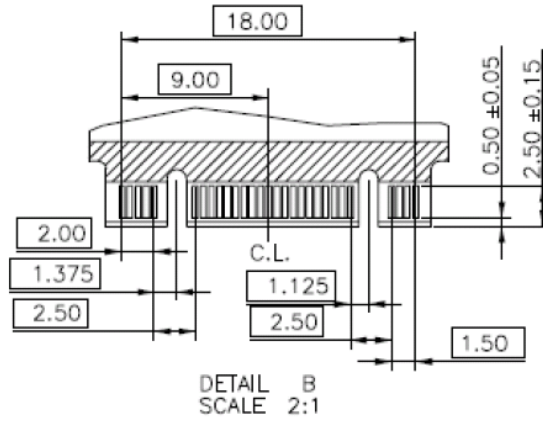
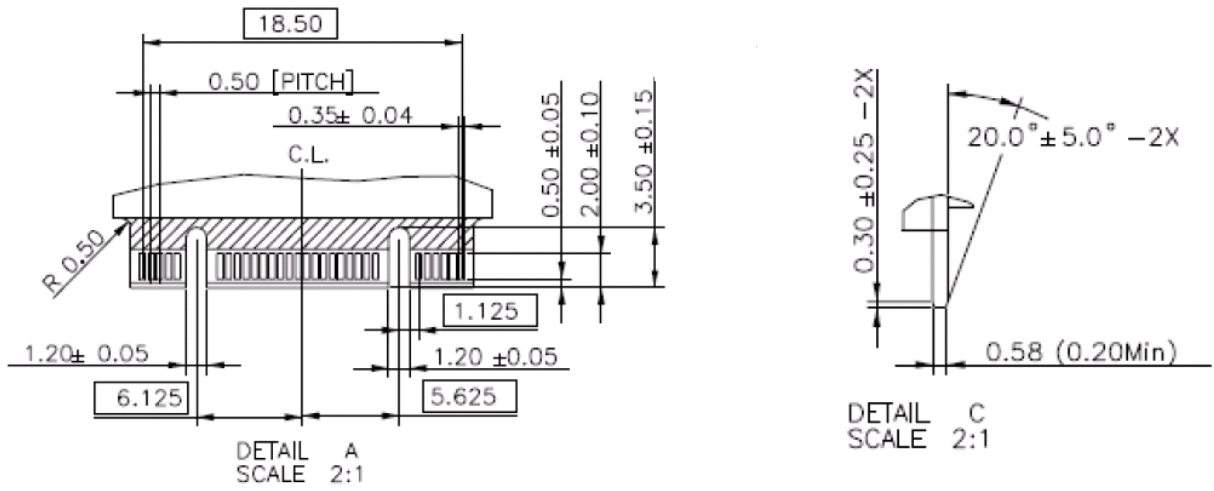

Unit: mm
 Tolerance: ±0.2 mm

7. Product Ordering Information

7.1 Product Code Designations

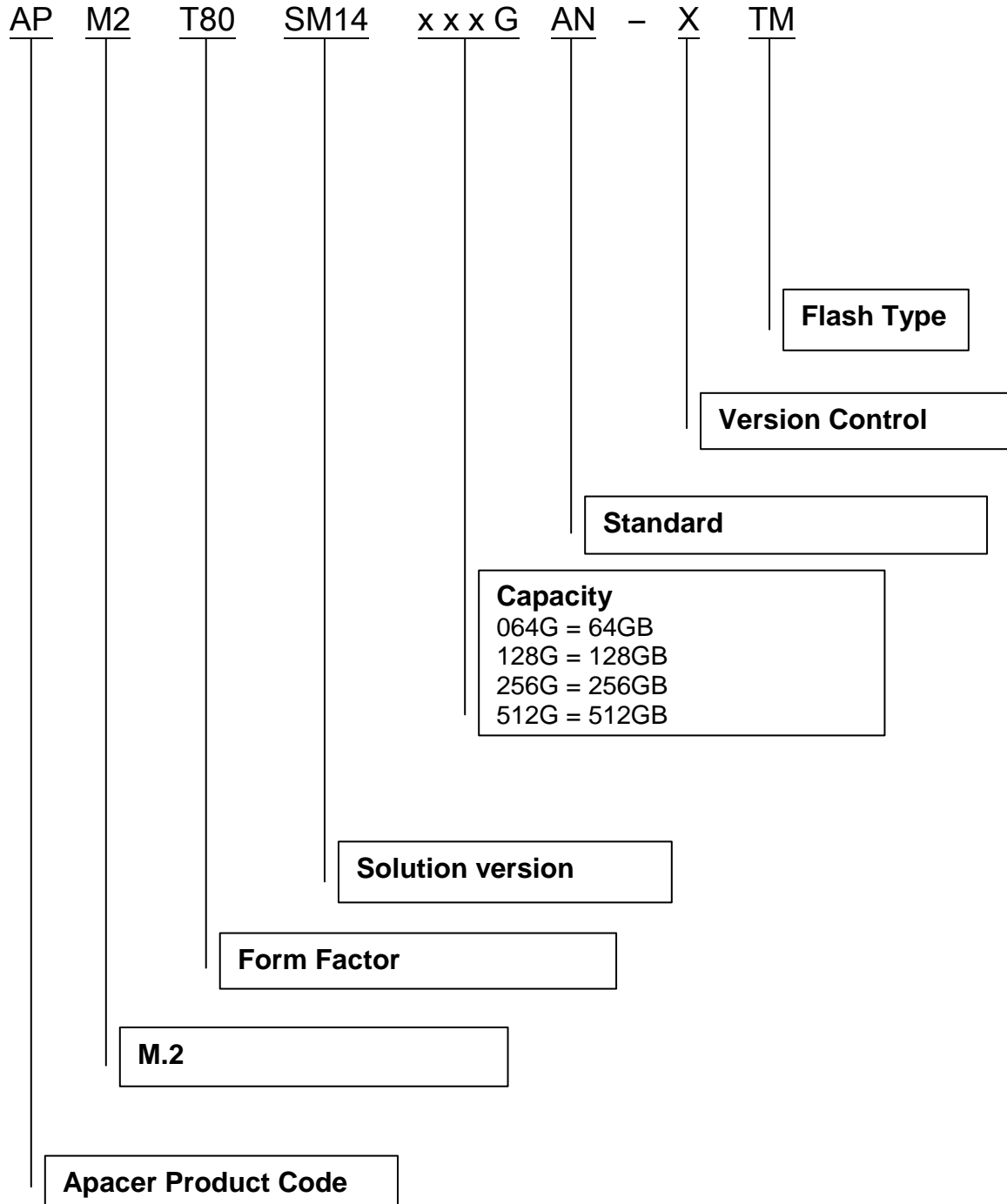

M.2 2280 Flash Drive
APM2T80SM14xxxGAN-XTM



7.2 Valid Combinations

Capacity	No DEVSLP	DEVSLP
64GB	APM2T80SM14064GAN-6TM	APM2T80SM14064GAN-7TM
128GB	APM2T80SM14128GAN-6TM	APM2T80SM14128GAN-7TM
256GB	APM2T80SM14256GAN-6TM	APM2T80SM14256GAN-7TM
512GB	APM2T80SM14512GAN-6TM	APM2T80SM14512GAN-7TM

Note: Valid combinations are those products in mass production or will be in mass production. Consult your Apacer sales representative to confirm availability of valid combinations and to determine availability of new combinations.

Revision History

Revision	Description	Date
1.0	Official release	2/5/2016
1.1	Specified single/double side for supported capacities	3/14/2016

Global Presence

Taiwan (Headquarters)	Apacer Technology Inc. 1F., No.32, Zhongcheng Rd., Tucheng Dist., New Taipei City 236, Taiwan R.O.C. Tel: 886-2-2267-8000 Fax: 886-2-2267-2261 amtsales@apacer.com
U.S.A.	Apacer Memory America, Inc. 46732 Lakeview Blvd., Fremont, CA 94538 Tel: 1-408-518-8699 Fax: 1-510-249-9568 sa@apacerus.com
Japan	Apacer Technology Corp. 5F, Matsura Bldg., Shiba, Minato-Ku Tokyo, 105-0014, Japan Tel: 81-3-5419-2668 Fax: 81-3-5419-0018 jpsservices@apacer.com
Europe	Apacer Technology B.V. Science Park Eindhoven 5051 5692 EB Son, The Netherlands Tel: 31-40-267-0000 Fax: 31-40-267-0000#6199 sales@apacer.nl
China	Apacer Electronic (Shanghai) Co., Ltd Room D, 22/FL, No.2, Lane 600, JieyunPlaza, Tianshan RD, Shanghai, 200051, China Tel: 86-21-6228-9939 Fax: 86-21-6228-9936 sales@apacer.com.cn
India	Apacer Technologies Pvt Ltd, Unit No.201, "Brigade Corner", 7 th Block Jayanagar, Yediyur Circle, Bangalore – 560082, India Tel: 91-80-4152-9061 Fax: 91-80-4170-0215 sales_india@apacer.com