

RoHS Compliant

Serial ATA Flash Drive

SK120 M.2 2280 Product Specifications

July 7, 2015

Version 1.4



Apacer Technology Inc.

1F, No.32, Zhongcheng Rd., Tucheng Dist., New Taipei City, Taiwan, R.O.C

Tel: +886-2-2267-8000

Fax: +886-2-2267-2261

www.apacer.com

Features:

- **Compliance with SATA Revision 3.1**
 - SATA 6.0 Gbps interface
 - Backward compatible with SATA 1.5/3.0 Gbps interfaces
 - ATA command set
- **Capacities**
 - 32, 64, 128 GB
- **Performance***
 - Interface burst read/write: 600 MB/sec
 - Sustained read: up to 530 MB/sec
 - Sustained write: up to 135 MB/sec
- **Flash Management**
 - Built-in hardware ECC
 - Wear leveling
 - Bad block management
 - S.M.A.R.T.
 - Power Failure Management
 - TRIM
- **NAND Flash Type: MLC**
- **Endurance**
 - 32GB: 28 TBW
 - 64GB: 57 TBW
 - 128GB: 114 TBW
- **Temperature ranges**
 - Operating: 0°C to 70°C
 - Storage: -40°C to 100°C
- **Supply voltage**
 - 3.3 V \pm 5%
- **Power consumption (typical)***
 - Active mode: 480 mA
 - Idle mode: 110 mA
- **Connector type**
 - 75-pin SATA-based M.2 module pinout
- **Form factor**
 - M.2 2280 form factor
 - Dimensions: 80.00x22.00x3.80, unit: mm
- **RoHS compliant**
- **Device Sleep**

*Varies from capacities. The values addressed here are typical and may vary depending on host system settings.

Table of Contents

1. Product Description	3
1.1 Introduction	3
1.2 Capacity Specification	3
1.3 Performance	3
1.4 Pin Assignments	4
2. Software Interface	6
2.1 Command Set	6
2.2 S.M.A.R.T.	6
3. Flash Management	7
3.1 Error Correction/Detection	7
3.2 Bad Block Management.....	7
3.3 Wear Leveling	7
3.4 Power Failure Management.....	7
3.5 TRIM	7
3.6 Secure Erase	7
3.7 Endurance.....	8
4. Environment Specifications.....	9
4.1 Environmental	9
4.2 Mean Time Between Failures (MTBF).....	9
4.3 Certification and Compliance	9
5. Electrical Characteristics.....	10
5.1 Operating Voltage.....	10
5.2 Power Consumption.....	10
6. Physical Characteristics.....	11
7. Product Ordering Information.....	13
7.1 Product Code Designations	13
7.2 Valid Combinations	14

1. Product Description

1.1 Introduction

Apacer's SK120 M.2 2280 is the next generation modularized Solid State Drive (SSD) with the shape of all new M.2 form factor, aimed to be the more suitable for mobile and compact computers with standard width at only 22.00 mm. SK120 M.2 2280 appears in M.2 2280 mechanical dimensions and is believed to be the leading add-in storage solution for future host computing systems.

The M.2 SSD is designed with SATA-based connector pinouts, providing full compliance with the latest SATA Revision 3.1 interface specifications. Aside from SATA compliance, SK120 M.2 2280 delivers exceptional performance and power efficiency. On the other hand, the extreme thin and light form factor makes SK120 M.2 2280 the ideal choice for mobile computing systems, which appears to be the trend in near future.

Regarding reliability, SK120 M.2 2280 is built with a powerful SATA controller that supports on-the-module ECC as well as efficient wear leveling scheme. In terms of power efficiency, SK120 M.2 2280 is compliant with SATA 6.0 Gbps interface standard so that it can operate on SATA power management modes, which greatly save on power consumption.

1.2 Capacity Specification

Table 1-1 Capacity Specification

Capacity	Total Bytes	Cylinders	Heads	Sectors	Max LBA
32 GB	32,017,047,552	16,383	16	63	62,533,296
64 GB	64,023,257,088	16,383	16	63	125,045,424
128 GB	128,035,676,160	16,383	16	63	250,069,680

*Display of total bytes varies from file systems.

**Cylinders, heads or sectors are not applicable for these capacities. Only LBA addressing applies.

LBA count addressed in the table above indicates total user storage capacity and will remain the same throughout the lifespan of the device. However, the total usable capacity of the SSD is most likely to be less than the total physical capacity because a small portion of the capacity is reserved for device maintenance usages.

1.3 Performance

Performance of SK120 M.2 2280 is shown in Table 1-2.

Table 1-2 Performance Specification

Capacity Performance	32 GB	64 GB	128 GB
Sustained Read (MB/s)	280	520	530
Sustained Write (MB/s)	70	130	135

Note: Performance varies from flash configurations or host system settings.

1.4 Pin Assignments

This connector does not support hot plug capability. There are a total of 75 pins. 12 pin locations are used for mechanical key locations; this allows such a module to plug into both Key B and Key M connectors.

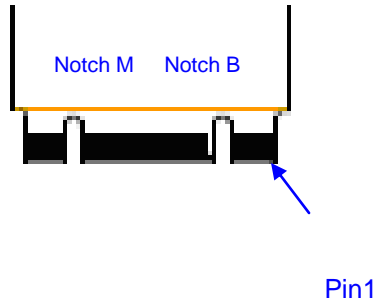

Table 1-3 Pin Assignments

Pin	Type	Description
1	CONFIG_3	Ground (according to M.2 configurations for SSD-SATA definition)
2	3.3V	Supply Pin, 3.3V
3	GND	Ground
4	3.3V	Supply pin, 3.3V
5	No connect	No connect
6	Not available	No connect (used for other purposes)
7	Not available	No connect (used for other purposes)
8	Not available	No connect (used for other purposes)
9	No connect	No connect
10	DAS/DSS	Device Activity Signal/Disable Staggered Spin-up
11	No connect	No connect (used for other purposes)
12	(removed for key)	Mechanical notch B
13	(removed for key)	Mechanical notch B
14	(removed for key)	Mechanical notch B
15	(removed for key)	Mechanical notch B
16	(removed for key)	Mechanical notch B
17	(removed for key)	Mechanical notch B
18	(removed for key)	Mechanical notch B
19	(removed for key)	Mechanical notch B
20	Not available	No connect (used for other purposes)
21	CONFIG_0	Ground (according to M.2 configurations for SSD-SATA definition)
22	Not available	No connect (used for other purposes)
23	Not available	No connect (used for other purposes)
24	Not available	No connect (used for other purposes)
25	Not available	No connect (used for other purposes)
26	Not available	No connect (used for other purposes)
27	GND	Ground
28	Not available	No connect (used for other purposes)
29	PERn1	Not used
30	Not available	No connect (used for other purposes)
31	PERp1	Not used
32	Not available	No connect (used for other purposes)
33	GND	Ground
34	Not available	No connect (used for other purposes)
35	PETn1	Not used
36	Not available	No connect (used for other purposes)

M.2 2280 Flash Drive
APM2T80P201xxxGAN-6MCM



Table 1-3 Pin Assignments

Pin	Type	Description
37	PETp1	Not used
38	DEVSLP	Device Sleep, input. If driven high the host is informing the SSD to enter a low power state
39	GND	Ground
40	Not available	No connect (used for other purposes)
41	SATA-Rx+	Host receiver differential signal pair
42	Not available	No connect (used for other purposes)
43	SATA-Rx-	Host receiver differential signal pair
44	Not available	No connect (used for other purposes)
45	GND	Ground
46	Not available	No connect (used for other purposes)
47	SATA-Tx-	Host transmitter differential pair
48	Not available	No connect (used for other purposes)
49	SATA-Tx+	Host transmitter differential pair
50	PERST#	Not used
51	GND	Ground
52	CLKREQ#	Not used
53	REFCLKN	Not used
54	PEWAKE#	Not used
55	REFCLKP	Not used
56	MFG1	Manufacturing pin. Use determined by vendor (no connect on a host)
57	GND	Ground
58	MFG2	Manufacturing pin. Use determined by vendor (no connect on a host)
59	(removed for key)	Mechanical notch M
60	(removed for key)	Mechanical notch M
61	(removed for key)	Mechanical notch M
62	(removed for key)	Mechanical notch M
63	(removed for key)	Mechanical notch M
64	(removed for key)	Mechanical notch M
65	(removed for key)	Mechanical notch M
66	(removed for key)	Mechanical notch M
67	Not available	No connect (used for other purposes)
68	SUSCLK	Not used
69	CONFIG_1	Ground
70	3.3V	Supply pin, 3.3V
71	GND	Ground
72	3.3V	Supply pin, 3.3V
73	GND	Ground
74	3.3V	Supply pin, 3.3V
75	CONFIG_2	Ground

2. Software Interface

2.1 Command Set

Table 2-1 summarizes the ATA commands supported by SK120 M.2 2280.

Table 2-1 Command Set

Code	Command	Code	Command
E5h	Check power mode	F6h	Security Disable Password
06h	Data Set management	F3h	Security Erase Prepare
B1H	DCO	F4h	Security Erase Unit
92h	Download Microcode PIO	F5h	Security Freeze Lock
93h	Download Microcode DMA	F1h	Security Set Password
90h	Execute drive diagnostic	F2h	Security Unlock
E7h	Flush cache	70h	Seek
EAh	Flush cache Ext	EFh	Set features
ECh	Identify device	F9h	Set Max Address
E3h	Idle	37h	Set Max Address Ext
E1h	Idle immediate	C6h	Set multiple mode
91h	Initialize drive parameters	E6h	Sleep
E4h	Read buffer	B0h	Smart
C9h	Read DMA (w/o retry)	E2h	Standby
C8h	Read DMA (w/retry)	E0h	Standby immediate
25h	Read DMA Ext	E8h	Write buffer
60h	Read FPDMA QUEUED	CBh	Write DMA (w/o retry)
2Fh	Read Log Ext	CAh	Write DMA (w/retry)
C4h	Read multiple	35h	Write DMA Ext
29h	Read multiple Ext	3Dh	Write DMA FUA Ext
F8h	Read native max address	61h	Write FPDMA QUEUED
27h	Read native max Ext	3Fh	Write Log Ext
21h	Read sector(s) (w/o retry)	C5h	Write multiple
20h	Read sector(s) (w/retry)	39h	Write multiple Ext
24h	Read sector(s) Ext	CEh	Write multiple FUA Ext
42h	Read Verify Ext	31h	Write sector(s) (w/o retry)
41h	Read verify sector(s) (w/o retry)	30h	Write sector(s) (w/retry)
40h	Read verify sector(s) (w/retry)	34h	Write sector(s) Ext
10h	Recalibrate	45h	Write uncorrectable

Note. Security command will only be workable when device runs in non-OPAL compliant mode.

2.2 S.M.A.R.T.

SMART, an acronym for Self-Monitoring, Analysis and Reporting Technology, is an open standard that allows a hard disk drive to automatically detect its health and report potential failures. When a failure is recorded by SMART, users can choose to replace the drive to prevent unexpected outage or data loss. Moreover, SMART can inform users of impending failures while there is still time to perform proactive actions, such as copy data to another device.

3. Flash Management

3.1 Error Correction/Detection

Flash memory cells will deteriorate with use, which might generate random bit errors in the stored data. Thus, this M.2 2280 SSD module applies the BCH ECC Algorithm, which can detect and correct errors occur during Read process, ensure data been read correctly, as well as protect data from corruption. This device can correct up to 72bit/1K data.

3.2 Bad Block Management

Bad blocks are blocks that include one or more invalid bits, and their reliability is not guaranteed. Blocks that are identified and marked as bad by the manufacturer are referred to as “Initial Bad Blocks”. Bad blocks that are developed during the lifespan of the flash are named “Later Bad Blocks”. Apacer implements an efficient bad block management algorithm to detect the factory-produced bad blocks and manages any bad blocks that appear with use. This practice further prevents data being stored into bad blocks and improves the data reliability.

3.3 Wear Leveling

NAND Flash devices can only undergo a limited number of program/erase cycles, and in most cases, the flash media are not used evenly. If some areas get updated more frequently than others, the lifetime of the device would be reduced significantly. Thus, Wear Leveling technique is applied to extend the lifespan of NAND Flash by evenly distributing write and erase cycles across the media.

Apacer provides advanced Wear Leveling algorithm, which can efficiently spread out the flash usage through the whole flash media area. Moreover, by implementing both dynamic and static Wear Leveling algorithms, the life expectancy of the NAND Flash is greatly improved.

3.4 Power Failure Management

Power Failure Management plays a crucial role when experiencing unstable power supply. Power disruption may occur when users are storing data into the SSD. In this urgent situation, the controller would run multiple flush cycles to store the metadata for later block rebuilding. This urgent operation requires about several milliseconds to get it done. At the next power up, the firmware will perform a status tracking to retrieve the mapping table and resume previously programmed NAND blocks to check if there is any incompleteness of transmission.

3.5 TRIM

TRIM is a feature which helps improve the read/write performance and speed of solid-state drives (SSD). Unlike hard disk drives (HDD), SSDs are not able to overwrite existing data, so the available space gradually becomes smaller with each use. With the TRIM command, the operating system can inform the SSD which blocks of data are no longer in use and can be removed permanently. Thus, the SSD will perform the erase action, which prevents unused data from occupying blocks all the time.

3.6 Secure Erase

Secure Erase is a standard ATA command and will write all “0xFF” to fully wipe all the data on hard drives and SSDs. When this command is issued, the SSD controller will empty its storage blocks and return to its factory default settings.

Note: Secure erase command belongs to ATA security command.

3.7 Endurance

The endurance of a storage device is predicted by Tera Bytes Written based on several factors related to usage, such as the amount of data written into the drive, block management conditions, and daily workload for the drive. Thus, key factors, such as Write Amplifications and the number of P/E cycles, can influence the lifespan of the drive.

Capacity	Tera Bytes Written
32 GB	28
64 GB	57
128 GB	114

Notes:

- The measurement assumes the data written to the SSD for test is under a typical and constant rate.
- The measurement follows the standard metric: 1 TB (Terabyte) = 1000 GB.
- This estimation complies with JEDEC JESD-219, enterprise endurance workload of random data with payload size distribution.

4. Environment Specifications

4.1 Environmental

Table 4-1 Environmental Specifications

Environment	Specification
Temperature	0°C to 70°C (Operating)
	-40°C to 100°C (in storage)
Humidity	RH 90% under 40°C
Shock	1500G, 0.5ms
Vibration	20Hz~80Hz/1.52mm (frequency/displacement)
	80Hz~2000Hz/20G (frequency/displacement)
	X, Y, Z axis/60mins each
Drop	80cm free fall, 6 face of each
Bending	≥ 20N, hold 1min/5times
Torque	0.5N-m or 5deg, hold 5min/5times
ESD	Pass

Note: Shock and Vibration specifications are subject to change without notice.

4.2 Mean Time Between Failures (MTBF)

MTBF, an acronym for Mean Time Between Failures, is a measure of a device's reliability. Its value represents the average time between a repair and the next failure. The measure is typically in units of hours. The higher the MTBF value, the higher the reliability of the device. The predicted result of this M.2 2280 device is higher than 1,000,000 hours.

4.3 Certification and Compliance

SK120 M.2 2280 complies with the following standards:

- SATA Revision 3.1
- RoHS
- ATA/ATAPI
- FCC
- CE
- BSMI

5. Electrical Characteristics

5.1 Operating Voltage

Table 5-1 lists the supply voltage for SK120 M.2 2280.

Table 5-1 Operating Voltage

Parameter	Conditions
Supply voltage	3.3V \pm 5%

5.2 Power Consumption

Table 5-2 lists the power consumption for SK120 M.2 2280.

Table 5-2 Power Consumption(typical)

Mode	Capacity	32 GB	64 GB	128 GB
Active (mA)		350	470	480
Idle (mA)		110	110	110

Note: Power consumptions may vary depending on host system settings.

6. Physical Characteristics

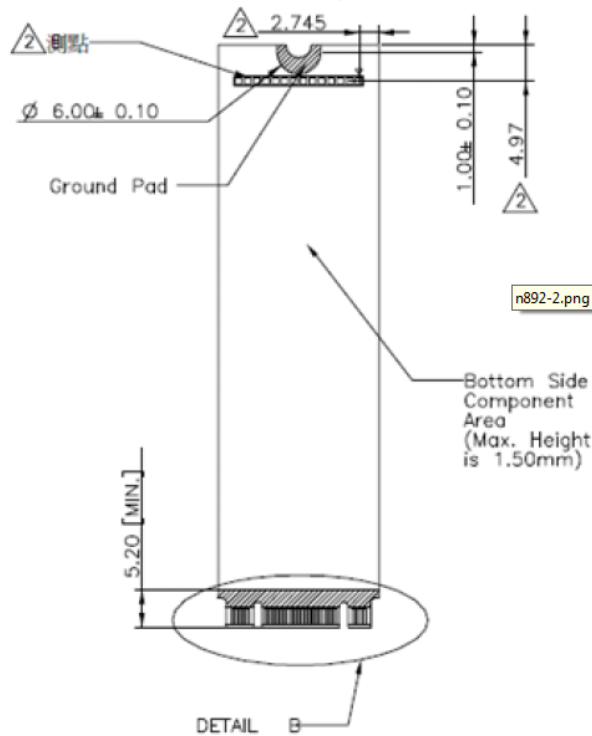
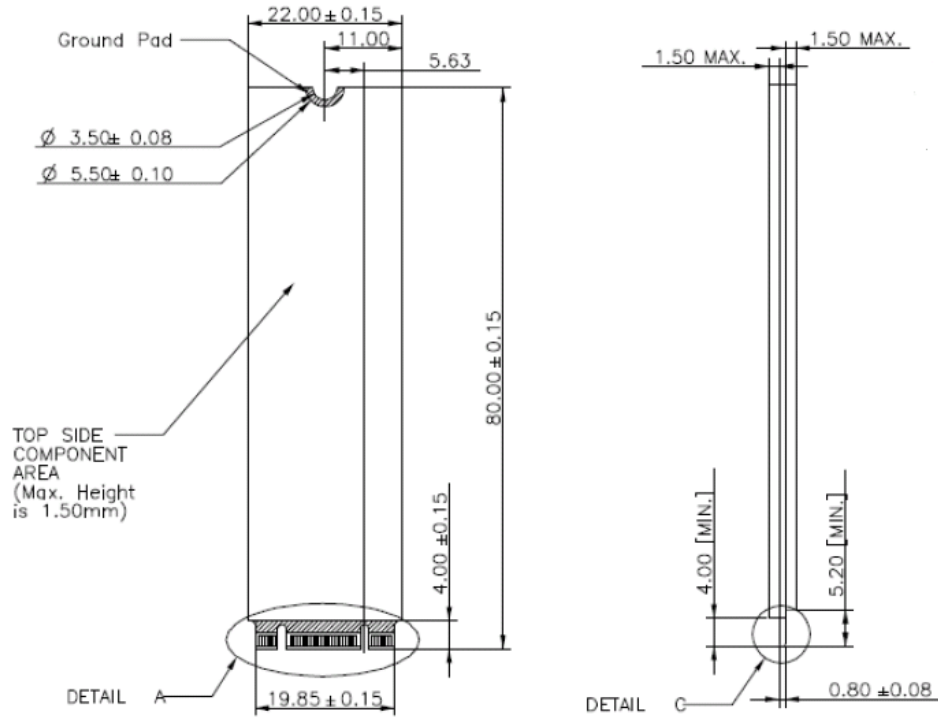

Unit: mm
 Tolerance: ±0.2 mm

M.2 2280 Flash Drive
 APM2T80P201xxxGAN-6MCM

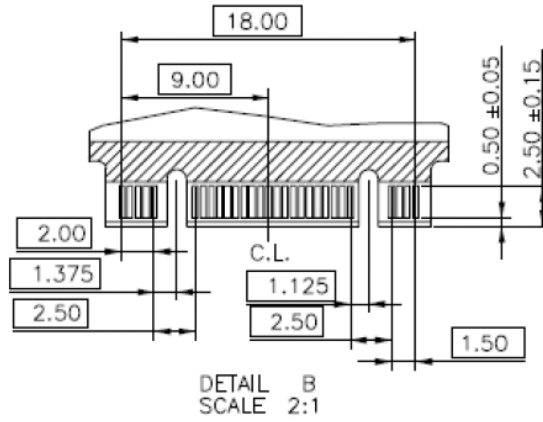
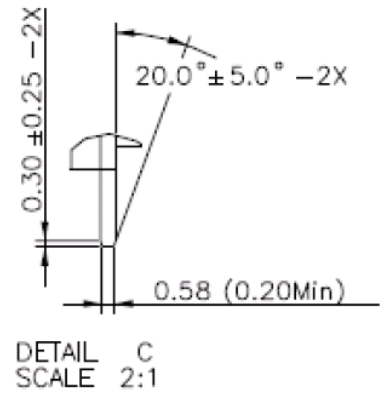
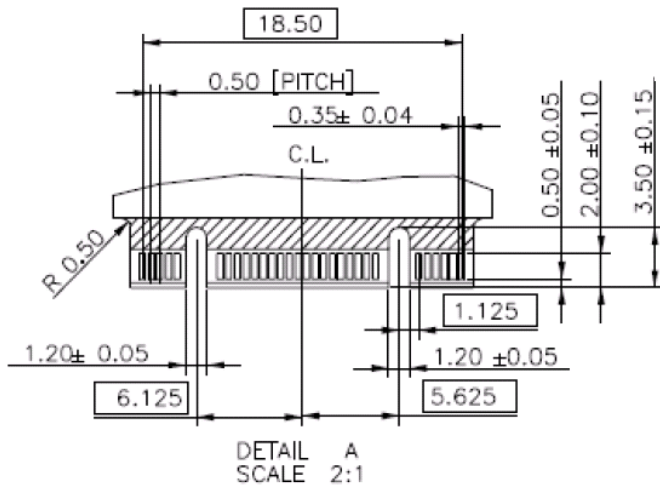

Unit: mm
 Tolerance: ± 0.2 mm

7. Product Ordering Information

7.1 Product Code Designations

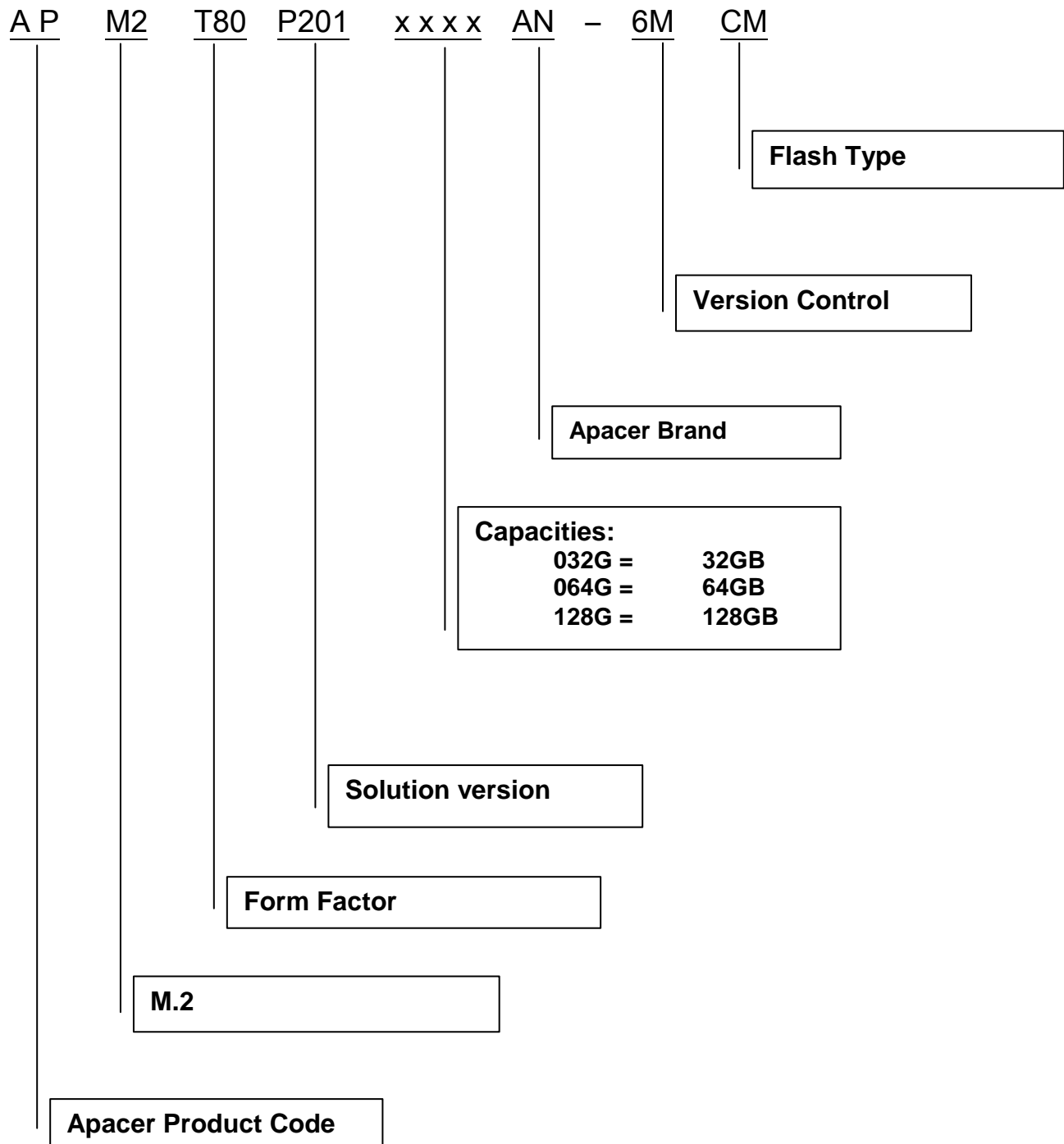

7.2 Valid Combinations

Capacity	DEVSLP
32GB	APM2T80P201032GAN-6MCM
64GB	APM2T80P201064GAN-6MCM
128GB	APM2T80P201128GAN-6MCM

Note: Valid combinations are those products in mass production or will be in mass production. Consult your Apacer sales representative to confirm availability of valid combinations and to determine availability of new combinations.

Revision History

Revision	Description	Date
1.0	Official release	02/16/2015
1.1	Revised series name : K1200-> SK120	04/09/2015
1.2	Revised performance and power consumption due to firmware change	04/13/2015
1.3	- Revised product ordering information - Revised storage temperature range : -40°C to 85°C->-40°C to 100°C	05/12/2015
1.4	Added endurance information	07/07/2015

Global Presence

Taiwan (Headquarters)	Apacer Technology Inc. 1F., No.32, Zhongcheng Rd., Tucheng Dist., New Taipei City 236, Taiwan R.O.C. Tel: 886-2-2267-8000 Fax: 886-2-2267-2261 amtsales@apacer.com
U.S.A.	Apacer Memory America, Inc. 386 Fairview Way, Suite102, Milpitas, CA 95035 Tel: 1-408-518-8699 Fax: 1-408-935-9611 sa@apacerus.com
Japan	Apacer Technology Corp. 5F, Matsura Bldg., Shiba, Minato-Ku Tokyo, 105-0014, Japan Tel: 81-3-5419-2668 Fax: 81-3-5419-0018 jpservices@apacer.com
Europe	Apacer Technology B.V. Science Park Eindhoven 5051 5692 EB Son, The Netherlands Tel: 31-40-267-0000 Fax: 31-40-267-0000#6199 sales@apacer.nl
China	Apacer Electronic (Shanghai) Co., Ltd 1301, No.251, Xiaomuqiao Road, Shanghai, 200032, China Tel: 86-21-5529-0222 Fax: 86-21-5206-6939 sales@apacer.com.cn
India	Apacer Technologies Pvt Ltd, # 535, 1st Floor, 8th cross, JP Nagar 3rd Phase, Bangalore – 560078, India Tel: 91-80-4152-9061 sales_india@apacer.com