

RoHS Recast Compliant

M.2 2260 Flash Drive

A200-MK Product Specifications

April 21st, 2014

Version 1.1



Apacer Technology Inc.

1F, No.32, Zhongcheng Rd., Tucheng Dist., New Taipei City, Taiwan, R.O.C

Tel: +886-2-2267-8000 Fax: +886-2-2267-2261

www.apacer.com

Features:

- **Standard SATA Interface Compliance**
 - Serial ATA Revision 3.2 compliance
 - SATA 6.0 Gbps interface
 - ATA-8 command set
- **Capacities**
 - 30, 60, 120, 240 GB
- **Performance***
 - Interface burst read/write: 600 MB/sec
 - Sustained read: up to 505 MB/sec
 - Sustained write: up to 285 MB/sec
 - Random read (4K): up to 69,000 IOPS
 - Random write (4K): up to 69,000 IOPS
- **Flash Management**
 - Built-in hardware ECC, enabling up to 40 bit correction per 1K bytes
 - Static/dynamic wear-leveling
 - Flash bad-block management
 - S.M.A.R.T.
 - Power Failure Management
 - ATA Secure Erase
 - TRIM
- **NAND Flash Type: MLC**
- **Temperature ranges**
 - Operating: 0°C to 70°C (32 ~ 158°F)
 - Storage: -40°C to 100°C (-40° ~ 212°F)
- **Supply voltage**
 - 3.3 V ± 5%
- **Power consumption (typical)***
 - Active mode: 810 mA
 - Idle mode: 100 mA
- **Connector type**
 - 75-pin SATA-based M.2 module pinout
- **Form factor**
 - M.2 2260 form factor
 - Dimensions: 22.00x 60.00x3.40, unit: mm
- **Shock & Vibration*****
 - Shock:1500 G
 - Vibration: 15 G
- **MTBF: >1,000,000 hours**
- **RoHS Recast compliant (complies with 2011/65/EU standard)**
- **Device Sleep mode**

*Varies from capacities. The values for performances and power consumptions presented are typical and may vary depending on flash configurations or platform settings. The term idle refers to the standby state of the device.

**Non-operating

Table of Contents

1. GENERAL DESCRIPTION	3
2. PIN ASSIGNMENTS	3
3. PRODUCT SPECIFICATIONS	6
3.1 CAPACITY	6
3.2 PERFORMANCE	6
3.3 ENVIRONMENTAL SPECIFICATIONS	7
3.4 MEAN TIME BETWEEN FAILURES (MTBF)	7
3.5 CERTIFICATION AND COMPLIANCE	7
4. FLASH MANAGEMENT	8
4.1 ERROR CORRECTION/DETECTION	8
4.2 BAD BLOCK MANAGEMENT	8
4.3 WEAR LEVELING	8
4.4 POWER FAILURE MANAGEMENT.....	8
4.5 ATA SECURE ERASE	8
4.6 TRIM	9
4.7 SATA POWER MANAGEMENT	9
5. SOFTWARE INTERFACE	10
5.1 COMMAND SET	10
5.2 S.M.A.R.T.....	10
6. ELECTRICAL SPECIFICATION	12
7. MECHANICAL SPECIFICATIONS	13
8. PRODUCT ORDERING INFORMATION	14

1. General Description

Apacer's A200-MK is the next generation modularized Solid State Drive (SSD) with the shape of all new M.2 form factor, aimed to be the more suitable for mobile and compact computers with standard width at only 22.00 mm. A200-MK appears in M.2 2260 mechanical dimensions and is believed to be the leading add-in storage solution for future host computing systems.

The M.2 SSD is designed with SATA-based connector pinouts, providing full compliance with the latest SATA Revision 3.2 interface specifications. Aside from SATA compliance, A200-MK delivers exceptional performance and power efficiency. On the other hand, the extreme thin and light form factor makes A200-MK the ideal choice for mobile computing systems, which appears to be the trend in near future.

Regarding reliability, A200-MK is built with a powerful SATA controller that supports on-the-module ECC as well as efficient wear leveling scheme. In terms of power efficiency, A200-MK is compliant with SATA 6.0 Gbps interface standard so that it can operate on SATA power management modes, which greatly save on power consumption.

2. Pin Assignments

This connector does not support hot plug capability. There are a total of 75 pins. 12 pin locations are used for mechanical key locations; this allows such a module to plug into both Key B and Key M connectors.

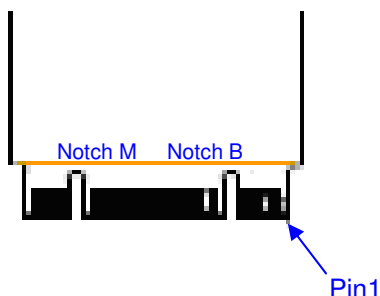

Pin	Type	Description
1	CONFIG_3	Ground (according to M.2 configurations for SSD-SATA definition)
2	3.3V	Supply Pin, 3.3V
3	GND	Ground
4	3.3V	Supply pin, 3.3V
5	No connect	No connect
6	Not available	No connect (used for other purposes)
7	Not available	No connect (used for other purposes)
8	Not available	No connect (used for other purposes)
9	No connect	No connect
10	DAS/DSS	Device Activity Signal/Disable Staggered Spin-up

M.2 2260 Flash Drive APM2T60A200xxxxD-2BXM

11	No connect	No connect (used for other purposes)
12	(removed for key)	Mechanical notch B
13	(removed for key)	Mechanical notch B
14	(removed for key)	Mechanical notch B
15	(removed for key)	Mechanical notch B
16	(removed for key)	Mechanical notch B
17	(removed for key)	Mechanical notch B
18	(removed for key)	Mechanical notch B
19	(removed for key)	Mechanical notch B
20	Not available	No connect (used for other purposes)
21	CONFIG_0	Ground (according to M.2 configurations for SSD-SATA definition)
22	Not available	No connect (used for other purposes)
23	Not available	No connect (used for other purposes)
24	Not available	No connect (used for other purposes)
25	Not available	No connect (used for other purposes)
26	Not available	No connect (used for other purposes)
27	GND	Ground
28	Not available	No connect (used for other purposes)
29	PERn1	Not used
30	Not available	No connect (used for other purposes)
31	PERp1	Not used
32	Not available	No connect (used for other purposes)
33	GND	Ground
34	Not available	No connect (used for other purposes)
35	PETn1	Not used
36	Not available	No connect (used for other purposes)
37	PETp1	Not used
38	DEVSLP	Device Sleep, input. If driven high the host is informing the SSD to enter a low power state (optional)
39	GND	Ground
40	Not available	No connect (used for other purposes)
41	SATA-Rx+	Host receiver differential signal pair
42	Not available	No connect (used for other purposes)
43	SATA-Rx-	Host receiver differential signal pair
44	Not available	No connect (used for other purposes)
45	GND	Ground
46	Not available	No connect (used for other purposes)

M.2 2260 Flash Drive
APM2T60A200xxxxD-2BXM



47	SATA-Tx-	Host transmitter differential pair
48	Not available	No connect (used for other purposes)
49	SATA-Tx+	Host transmitter differential pair
50	PERST#	Not used
51	GND	Ground
52	CLKREQ#	Not used
53	REFCLKN	Not used
54	PEWAKE#	Not used
55	REFCLKP	Not used
56	MFG1	Manufacturing pin. Use determined by vendor (no connect on a host)
57	GND	Ground
58	MFG2	Manufacturing pin. Use determined by vendor (no connect on a host)
59	(removed for key)	Mechanical notch B
60	(removed for key)	Mechanical notch B
61	(removed for key)	Mechanical notch B
62	(removed for key)	Mechanical notch B
63	(removed for key)	Mechanical notch B
64	(removed for key)	Mechanical notch B
65	(removed for key)	Mechanical notch B
66	(removed for key)	Mechanical notch B
67	Not available	No connect (used for other purposes)
68	SUSCLK	Not used
69	CONFIG_1	Ground
70	3.3V	Supply pin, 3.3V
71	GND	Ground
72	3.3V	Supply pin, 3.3V
73	GND	Ground
74	3.3V	Supply pin, 3.3V
75	CONFIG_2	Ground

3. Product Specifications

3.1 Capacity

Capacity specification of A200-MK is available as shown in Table 3-1. It lists the specific capacity and the default numbers of heads, sectors and cylinders for each product line.

Table 3-1: Capacity specifications

Capacity	Total Bytes	Cylinders	Heads	Sectors	Max LBA
30 GB	30,016,659,456	16,383	16	63	58,626,288
60 GB	60,022,480,896	16,383	16	63	117,231,408
120 GB	120,034,123,776	16,383	16	63	234,441,648
240 GB	240,057,409,536	16,383	16	63	468,862,128

*Display of total bytes varies from file systems, which means not all of the bytes can be used for storage.

**Notes: 1 GB = 1,000,000,000 bytes; 1 sector = 512 bytes.

LBA count addressed in the table above indicates total user storage capacity and will remain the same throughout the lifespan of the device. However, the total usable capacity of the SSD is most likely to be less than the total physical capacity because a small portion of the capacity is reserved for device maintenance usages.

3.2 Performance

Performances of A200-MK are listed below in table 3-2.

Table 3-2: Performance

Capacity	30 GB	60 GB	120 GB	240 GB
Performance				
Sustained read (MB/s)	180	265	505	505
Sustained write (MB/s)	38	75	145	285
Random Read 4K (IOPS)	19,000	34,000	62,000	69,000
Random Write 4K (IOPS)	8,000	18,000	35,000	69,000

Note: Results may differ from various flash configurations or host system setting
 IOPS: measured on 8GB span (16777216 sectors Disk Size), 32 Outstanding I/Os (QD=32), Full Random Data pattern, 4KB Align I/Os and test durations 15minutes.

3.3 Environmental Specifications

Environmental specification of A200-MK series follows MIL-STD-810 standards as shown in Table 3-3.

Table 3-3 A200-MK environmental specifications

Item	Specification
Operating temp.	0~70°C
Non-operating temp.	-40~100(°C)
Operating vibration	20~2000(Hz), 7.69 (Grms), random wave, X, Y, Z axis
Non-operating vibration	10~2000(Hz), 15(G), sine wave, X, Y, Z axis
Operating shock	50(G), 11(ms), half-sine wave
Non-operating shock	1500(G), 0.5(ms), half-sine wave

3.4 Mean Time Between Failures (MTBF)

Mean Time Between Failures (MTBF) is predicted based on reliability data for the individual components in A200-MK. The prediction result for A200-MK is more than 1,000,000 hours.

Notes about the MTBF:

The MTBF is predicated and calculated based on “Telcordia Technologies Special Report, SR-332, Issue 2” method.

3.5 Certification and Compliance

A200-MK complies with the following standards:

- CE
- FCC
- RoHS Recast
- MIL-STD-810

4. Flash Management

4.1 Error Correction/Detection

A200-MK implements a hardware ECC scheme, based on the BCH algorithm. It can detect and correct up to 40 bits error in 1K bytes.

4.2 Bad Block Management

Current production technology is unable to guarantee total reliability of NAND flash memory array. When a flash memory device leaves factory, it comes with a minimal number of initial bad blocks during production or out-of-factory as there is no currently known technology that produce flash chips free of bad blocks. In addition, bad blocks may develop during program/erase cycles. When host performs program/erase command on a block, bad block may appear in Status Register. Since bad blocks are inevitable, the solution is to keep them in control. Apacer flash devices are programmed with ECC, block mapping technique and S.M.A.R.T to reduce invalidity or error. Once bad blocks are detected, data in those blocks will be transferred to free blocks and error will be corrected by designated algorithms.

4.3 Wear Leveling

Flash memory devices differ from Hard Disk Drives (HDDs) in terms of how blocks are utilized. For HDDs, when a change is made to stored data, like erase or update, the controller mechanism on HDDs will perform overwrites on blocks. Unlike HDDs, flash blocks cannot be overwritten and each P/E cycle wears down the lifespan of blocks gradually. Repeatedly program/erase cycles performed on the same memory cells will eventually cause some blocks to age faster than others. This would bring flash storages to their end of service term sooner. Wear leveling is an important mechanism that level out the wearing of blocks so that the wearing-down of blocks can be almost evenly distributed. This will increase the lifespan of SSDs. Commonly used wear leveling types are Static and Dynamic.

4.4 Power Failure Management

Power Failure Management plays a crucial role when experiencing unstable power supply. Power disruption may occur when users are storing data into the SSD. In this urgent situation, the controller would run multiple write-to-flash cycles to store the metadata for later block rebuilding. This urgent operation requires about several milliseconds to get it done. At the next power up, the firmware will perform a status tracking to retrieve the mapping table and resume previously programmed NAND blocks to check if there is any incompleteness of transmission.

Note: The controller unit of this product model is designed with a DRAM as a write cache for improved performance and data efficiency. Though unlikely to happen in most cases, the data cached in the volatile DRAM might be potentially affected if a sudden power loss takes place before the cached data is flushed into non-volatile NAND flash memory.

4.5 ATA Secure Erase

ATA Secure Erase is an ATA disk purging command currently embedded in most of the storage drives. Defined in ATA specifications, (ATA) Secure Erase is part of Security Feature Set that allows storage drives to erase all user data areas. The erase process usually runs on the firmware level as most of the ATA-based storage media currently in the market are built-in with this command. ATA Secure Erase can securely wipe out the user data in the drive and protects it from malicious attack.

4.6 TRIM

TRIM is a SATA command that helps improve the read/write performance and efficiency of solid-state drives (SSD). The command enables the host operating system to inform SSD controller which blocks contain invalid data, mostly because of the erase commands from host. The invalid will be discarded permanently and the SSD will retain more space for itself.

4.7 SATA Power Management

By complying with SATA 6.0 Gb/s specifications, the SSD supports the following SATA power saving modes:

- ACTIVE: PHY ready, full power, Tx & Rx operational
- PARTIAL: Reduces power, resumes in under 10 μ s (microseconds)
- SLUMBER: Reduces power, resumes in under 10 ms (milliseconds)
- HIPM: Host-Initiated Power Management
- DIPM: Device-Initiated Power Management
- AUTO-SLUMBER: Automatic transition from partial to slumber.
- Device Sleep (DevSleep or DEVSLP): PHY powered down; power consumption \leq 5 mW; host assertion time \leq 10 ms; exit timeout from this state \leq 20 ms (unless specified otherwise in SATA Identify Device Log).

Note:

1. The behaviors of power management features would depend on host/device settings.

5. Software Interface

5.1 Command Set

This section defines the software requirements and the format of the commands the host sends to A200-MK. Commands are issued to A200-MK by loading the required registers in the command block with the supplied parameters, and then writing the command code to the Command register.

Table 6-1: Command set

Code	Command	Code	Command
E5h	Check Power Mode	F3h	Security Erase Prepare
06h	Data Set Management	F4h	Security Erase Unit
90h	Execute Device Diagnostic	F5h	Security Freeze Lock
E7h	Flush Cache	F1h	Security Set Password
EAh	Flush Cache EXT	F2h	Security Unlock
Ech	Identify Device	70h	Seek
E3h	Idle	Efh	Set Features
E1h	Idle Immediate	C6h	Set Multiple Mode
91h	Initialize Device Parameters	E6h	Sleep
C8h	Read DMA	B0h	SMART
25h	Read DMA EXT	E2h	Standby
C4h	Read Multiple	E0h	Standby Immediate
29h	Read Multiple EXT	Cah	Write DMA
20h	Read Sector	35h	Write DMA EXT
24h	Read Sector EXT	C5h	Write Multiple
40h	Read Verify Sectors	39h	Write Multiple EXT
42h	Read Verify Sectors EXT	30h	Write Sector
10h	Recalibrate	34h	Write Sector EXT
F6h	Security Disable Password		

5.2 S.M.A.R.T.

S.M.A.R.T. is an abbreviation for Self-Monitoring, Analysis and Reporting Technology, a self-monitoring system that provides indicators of drive health as well as potential disk problems. It serves as a warning for users from unscheduled downtime by monitoring and displaying critical drive information. Ideally, this should allow taking proactive actions to prevent drive failure and make use of S.M.A.R.T. information for future product development reference.

Apacer devices use the standard SMART command B0h to read data out from the drive to activate our S.M.A.R.T. feature that complies with the ATA/ATAPI specifications. S.M.A.R.T. Attribute IDs shall

M.2 2260 Flash Drive APM2T60A200xxxxD-2BXM



include initial bad block count, total later bad block count, maximum erase count, average erase count, power on hours and power cycle. When the S.M.A.R.T. Utility running on the host, it analyzes and reports the disk status to the host before the device reaches in critical condition.

Note: attribute IDs may vary from product models due to various solution design and supporting capabilities.

Apacer memory products come with S.M.A.R.T. commands and subcommands for users to obtain information of drive status and to predict potential drive failures. Users can take advantage of the following commands/subcommands to monitor the health of the drive.

Code	SMART Subcommand
D0h	READ DATA
D1h	READ ATTRIBUTE THRESHOLDS
D2h	Enable/Disable Attribute Autosave
D4h	Execute Off-line Immediate
D5h	Read Log (optional)
D6h	Write Log (optional)
D8h	Enable Operations
D9h	Disable operations
Dah	Return Status

General SMART attribute structure

Byte	Description
0	ID (Hex)
1 – 2	Status flag
3	Value
4	Worst
5*-11	Raw Data

*Byte 5: LSB

SMART attribute ID list

ID (Hex)	Attribute Name
9 (0x09)	Power-on hours
12 (0x0C)	Power cycle count
163 (0xA3)	Max. erase count
164 (0xA4)	Avg. erase count
166 (0xA6)	Total later bad block count
167 (0xA7)	SSD Protect Mode (vendor specific)
168 (0xA8)	SATA PHY Error Count
175 (0xAF)	Bad Cluster Table Count
192 (0xC0)	Unexpected Power Loss Count
194 (0xC2)	Temperature
241 (0xF1)	Total sectors of write

6. Electrical Specification

Table 6-1: Operating range

Ambient Temperature	0°C to +70°C
Supply Voltage	3.3V±5% (3.135-3.465V)

Table 6-2: Typical power consumption

Capacity	30 GB	60 GB	120 GB	240 GB
Modes				
Active (mA)	270	350	490	810
Idle (mA)	75	100	100	100

Note: Results may differ from various flash configurations or host system setting

7. Mechanical Specifications

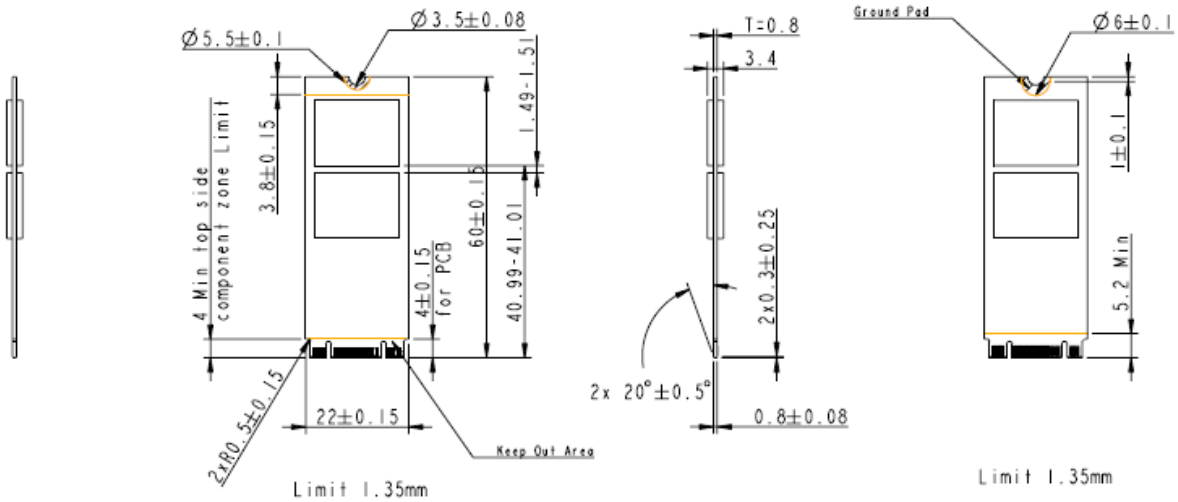

Unit: mm
 Tolerance: ± 0.25

8. Product Ordering Information

8.1 Product Code Designations

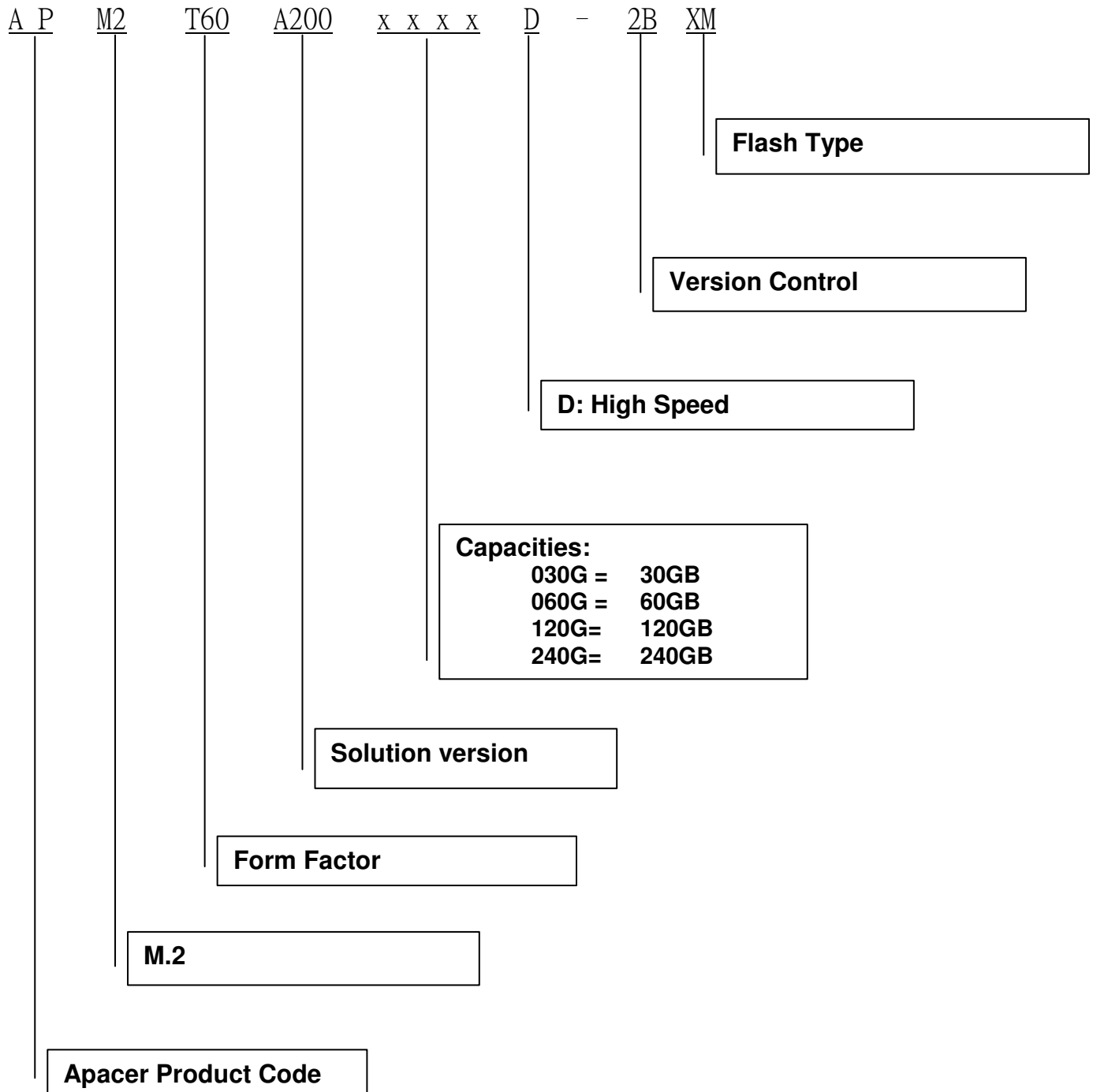

8.2 Valid Combinations

Capacity	DEVSLP
30GB	APM2T60A200030GD-2BCM
60GB	APM2T60A200060GD-2BLM
120GB	APM2T60A200120GD-2BLM
240GB	APM2T60A200240GD-2BLM

Note: Please consult with Apacer sales representatives for availabilities.

Revision History

Revision	Date	Description	Remark
1.0	04/09/2014	Official release	
1.1	04/21/2014	Updated product ordering information due to change in NAND flash configurations	

Global Presence

Taiwan (Headquarters)	Apacer Technology Inc. Apacer Technology Inc. 1F., No.32, Zhongcheng Rd., Tucheng Dist., New Taipei City 236, Taiwan R.O.C. Tel: 886-2-2267-8000 Fax: 886-2-2267-2261 amtsales@apacer.com
U.S.A.	Apacer Memory America, Inc. 386 Fairview Way, Suite102, Milpitas, CA 95035 Tel: 1-408-518-8699 Fax: 1-408-935-9611 sa@apacerus.com
Japan	Apacer Technology Corp. 5F, Matsura Bldg., Shiba, Minato-Ku Tokyo, 105-0014, Japan Tel: 81-3-5419-2668 Fax: 81-3-5419-0018 jpservices@apacer.com
Europe	Apacer Technology B.V. Science Park Eindhoven 5051 5692 EB Son, The Netherlands Tel: 31-40-267-0000 Fax: 31-40-267-0000#6199 sales@apacer.nl
China	Apacer Electronic (Shanghai) Co., Ltd 1301, No.251,Xiaomuqiao Road, Shanghai, 200032, China Tel: 86-21-5529-0222 Fax: 86-21-5206-6939 sales@apacer.com.cn
India	Apacer Technologies Pvt Ltd, # 535, 1st Floor, 8th cross, JP Nagar 3rd Phase, Bangalore – 560078, India Tel: 91-80-4152-9061 sales_india@apacer.com