

RoHS Compliant

SATA Flash Drive

SU130-25 2.5" Product Specifications

October 11, 2017

Version 1.0



Apacer Technology Inc.

1F, No.32, Zhongcheng Rd., Tucheng Dist., New Taipei City, Taiwan, R.O.C

Tel: +886-2-2267-8000 Fax: +886-2-2267-2261

www.apacer.com

Features:

- **Serial ATA Revision 3.2 Compliance**
 - SATA 6.0 Gbps interface
 - Backward compatible with SATA 3.0/1.5 Gbps interface
 - ATA Command set
- **Capacity**
 - 512 GB
- **Performance***
 - Burst read/write: 600 MB/sec
 - Sequential read: up to 550 MB/sec
 - Sequential write: up to 530 MB/sec
- **Flash Management**
 - Built-in hardware ECC
 - Global Wear Leveling
 - Flash bad block management
 - S.M.A.R.T.
 - Power Failure Management
 - TRIM
- **NAND Flash Type:** MLC
- **Firmware Version:** SLC-lite
- **MTBF (hours):** >1,000,000
- **Endurance (in Terabytes Written: TBW)**
 - 512 GB: 5,300 TBW
- **Temperature Range**
 - Operating:
 - Standard: 0°C to 70°C
 - Extended: -40°C to 85°C
 - Storage: -40°C to 85°C
- **Supply Voltage**
 - 5 V ± 5%
- **Power Consumption***
 - Active mode: 905 mA@5 V
 - Idle mode: 95 mA@5 V
- **Form Factor**
 - 2.5 inch (100.10 x 69.85 x 7.00, unit: mm)
- **Connector**
 - 7-pin SATA male connector
 - 15-pin SATA power connector
- **Shock & Vibration****
 - Shock: 1,500 G
 - Vibration: 15 G
- **DDR3 Cache for Enhanced Random Performance**
- **Device Sleep**
- **RoHS Compliant**

*The values presented for Performances and Power Consumption are typical and may vary depending on different configurations and platforms.

**Non-operating

Table of Contents

1. Product Description	3
1.1 Introduction	3
1.2 Capacity Specifications	3
1.3 Performance	3
1.4 Pin Assignments	4
2. Software Interface	6
2.1 Command Set	6
2.2 S.M.A.R.T.	6
3. Flash Management	7
3.1 Error Correction/Detection	7
3.2 Flash Block Management	7
3.3 Global Wear Leveling	7
3.4 Power Failure Management.....	7
3.5 ATA Secure Erase	7
3.6 TRIM	8
3.7 SLC-lite Technology.....	8
4. Reliability Specifications	9
4.1 Environments	9
4.2 Mean Time Between Failures (MTBF).....	9
4.3 Certification and Compliance	9
4.4 Endurance.....	9
5. Electrical Characteristics.....	10
5.1 Operating Voltage	10
5.2 Power Consumption.....	10
6. Mechanical Specifications	11
7. Product Ordering Information.....	12
7.1 Product Code Designation.....	12
7.2 Valid Combinations	13

1. Product Description

1.1 Introduction

Apacer SU130-25 (2.5 inch) Embedded Solid State Drive is a speedy and reliable companion for industrial PC and laptops. Designed in SATA 6.0 Gb/s interface, the drive can deliver outstanding performance up to 550 MB/s sustained transfer rate, highly suitable to serve as operating system boot drive or storage media of important data. With its compliance with the latest SATA specification, this cutting edge device supports power management, which greatly saves in power consumption, making it more environmental and economical than traditional hard disk drives.

Regarding data reliability, the controller unit of SU130-25 is built with a powerful ECC engine in the device correcting up to 72bit per 1KB data. For better I/O performance, the controller unit comes with an external DDR3 cache to strengthen the IOPS (Input Output Per Second) of the device, proving to be the ideal companion for PC and laptop users.

1.2 Capacity Specifications

Table 1-1 Capacity Specifications

Capacity	Total Bytes*	Cylinders	Heads	Sectors	Max LBA**
512 GB	512,110,190,592	16383	16	63	1,000,215,216

*Display of total bytes varies from file systems.

**Cylinders, heads or sectors are not applicable for these capacities. Only LBA addressing applies.

***Notes: 1 GB = 1,000,000,000 bytes; 1 sector = 512 bytes.

LBA count addressed in the table above indicates total user storage capacity and will remain the same throughout the lifespan of the device. However, the total usable capacity of the SSD is most likely to be less than the total physical capacity because a small portion of the capacity is reserved for device maintenance usages.

1.3 Performance

Table 1-2 Performance Specifications

	Capacity
Performance	512 GB
Sequential Read (MB/s)	550
Sequential Write (MB/s)	530

Note:

Results may differ from various flash configurations or host system setting.

*Sequential performance is based on CrystalDiskMark 5.2.1 with file size 1,000MB.

1.4 Pin Assignments

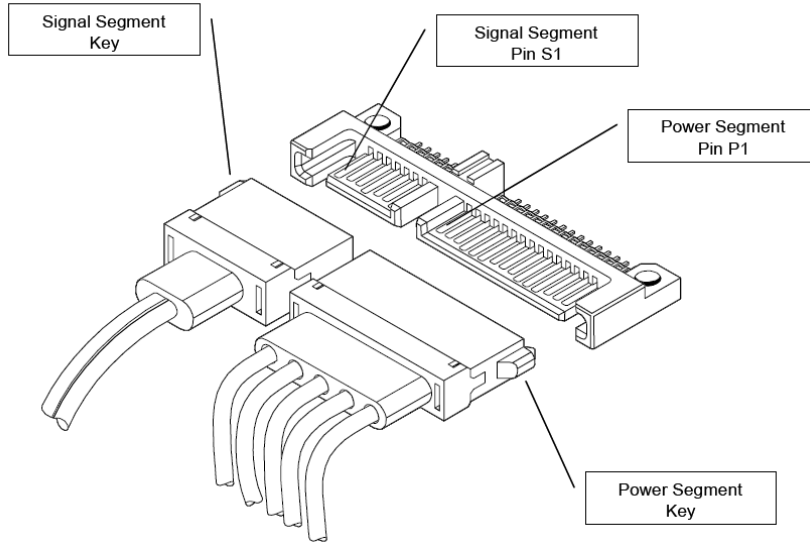

Table 1-3 Signal Segment

Pin	Type	Description
S1	GND	
S2	RxP	Serial Data Receiver Signal Pair
S3	RxN	
S4	GND	
S5	TxN	Serial Data Transmitter Signal Pair
S6	TxP	
S7	GND	

Table 1-4 Power Segment

Pin	Signal/Description
P1	Not used (3.3V)
P2	Not used (3.3V)
P3	Device Sleep
P4	Ground
P5	Ground
P6	Ground
P7	5V
P8	5V
P9	5V
P10	Ground
P11	Reserved
P12	Ground
P13	Not used (12V)
P14	Not used (12V)
P15	Not used (12V)

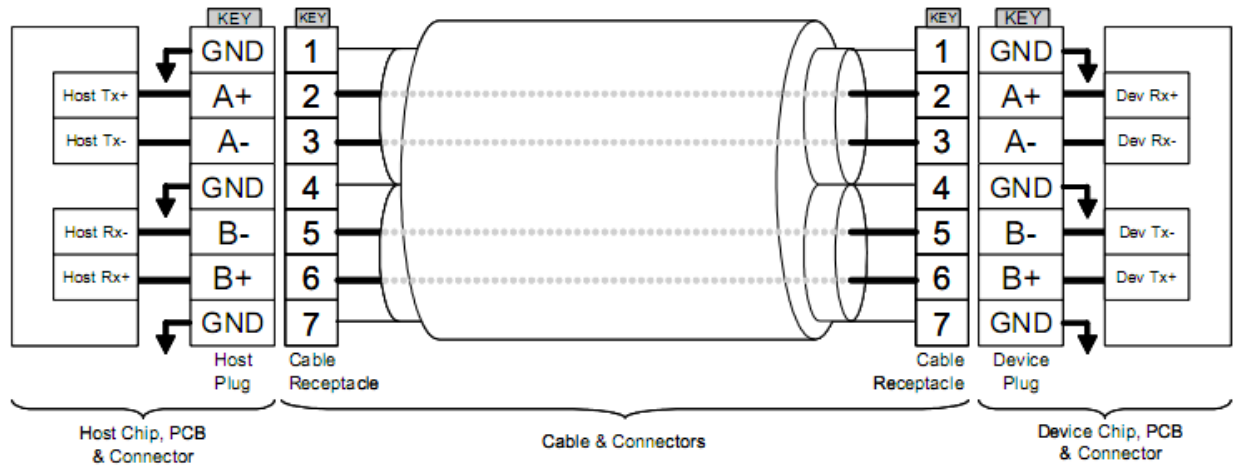

Figure 1-1 SATA Cable / Connector Connection Diagram

The connector on the left represents the Host with TX/RX differential pairs connected to a cable while the connector on the right shows the Device with TX/RX differential pairs also connected to the cable. Notice also the ground path connecting the shielding of the cable to the Cable Receptacle.

2. Software Interface

2.1 Command Set

Table 2-1 Command Set

Command	Code	Command	Code
CHECK Power Mode	E5h	Security Disable Password	F6h
Data Set Management	06h	Security Erase Prepare	F3h
DCO	B1h	Security Erase Unit	F4h
Download Microcode PIO	92h	Security Freeze Lock	F5h
Download Microcode DMA	93h	Security Set Password	F1h
Execute Drive Diagnostic	90h	Security Unlock	F2h
Flush Cache	E7h	Seek	70h
Flush Cache Ext	EAh	Set Features	EFh
Identify Device	ECh	Set Max Address	F9h
Idle	E3h	Set Max Address Ext	37h
Idle Immediate	E1h	Set Multiple Mode	C6h
Initialize Drive Parameters	91h	Sleep	E6h
Read Buffer	E4h	SMART	B0h
Read DMA (W/O retry)	C9h	Standby	E2h
Read DMA (W/ retry)	C8h	Standby Immediate	E0h
Read DMA Ext	25h	Write Buffer	E8h
Read FPDMA Queued	60h	Write DMA (W/O retry)	CBh
Read Log Ext	2Fh	Write DMA (W/ retry)	CAh
Read Multiple	C4h	Write DMA Ext	35h
Read Multiple Ext	29h	Write DMA FUA Ext	3Dh
Read Native Max Address	F8h	Write FPDMA Queued	61h
Read Native Max Ext	27h	Write Log Ext	3Fh
Read Sector(s) (W/O retry)	21h	Write Multiple	C5h
Read Sector(s) (W/ retry)	20h	Write Multiple Ext	39h
Read Sector(s) Ext	24h	Write Multiple FUA Ext	CEh
Read Verify Ext	42h	Write Sector(s) (W/O retry)	31h
Read Verify Sector(s) (W/O retry)	41h	Write Sector(s) (W/ retry)	30h
Read Verify sector(s) (W/ retry)	40h	Write Sector(s) Ext	34h
Recalibrate	10h	Write Uncorrectable	45h

2.2 S.M.A.R.T.

S.M.A.R.T. is an acronym for Self-Monitoring, Analysis and Reporting Technology, an open standard allowing disk drives to automatically monitor their own health and report potential problems. It protects the user from unscheduled downtime by monitoring and storing critical drive performance and calibration parameters. Ideally, this should allow taking proactive actions to prevent impending drive failure.

3. Flash Management

3.1 Error Correction/Detection

This device implements hardware ECC scheme based on the BCH algorithm which can detect and correct up to 72 bits error in 1K Bytes.

3.2 Flash Block Management

Current production technology is unable to guarantee total reliability of NAND flash memory array. When a flash memory device leaves factory, it comes with a minimal number of initial bad blocks during production or out-of-factory as there is no currently known technology that produce flash chips free of bad blocks. In addition, bad blocks may develop during program/erase cycles. When host performs program/erase command on a block, bad block may appear in Status Register. Since bad blocks are inevitable, the solution is to keep them in control. Apacer flash devices are programmed with ECC, block mapping technique and S.M.A.R.T to reduce invalidity or error. Once bad blocks are detected, data in those blocks will be transferred to free blocks and error will be corrected by designated algorithms.

3.3 Global Wear Leveling

Flash memory devices differ from Hard Disk Drives (HDDs) in terms of how blocks are utilized. For HDDs, when a change is made to stored data, like erase or update, the controller mechanism on HDDs will perform overwrites on blocks. Unlike HDDs, flash blocks cannot be overwritten and each P/E cycle wears down the lifespan of blocks gradually. Repeatedly program/erase cycles performed on the same memory cells will eventually cause some blocks to age faster than others. This would bring flash storages to their end of service term sooner. Global wear leveling is an important mechanism that levels out the wearing of all blocks so that the wearing-down of all blocks can be almost evenly distributed. This will increase the lifespan of SSDs.

3.4 Power Failure Management

Power Failure Management plays a crucial role when experiencing unstable power supply. Power disruption may occur when users are storing data into the SSD. In this urgent situation, the controller would run multiple write-to-flash cycles to store the metadata for later block rebuilding. This urgent operation requires about several milliseconds to get it done. At the next power up, the firmware will perform a status tracking to retrieve the mapping table and resume previously programmed NAND blocks to check if there is any incompleteness of transmission.

Note: The controller unit of this product model is designed with a DRAM as a write cache for improved performance and data efficiency. Though unlikely to happen in most cases, the data cached in the volatile DRAM might be potentially affected if a sudden power loss takes place before the cached data is flushed into non-volatile NAND flash memory.

3.5 ATA Secure Erase

ATA Secure Erase is an ATA disk purging command currently embedded in most of the storage drives. Defined in ATA specifications, (ATA) Secure Erase is part of Security Feature Set that allows storage drives to erase all user data areas. The erase process usually runs on the firmware level as most of the ATA-based storage media currently in the market are built-in with this command. ATA Secure Erase can securely wipe out the user data in the drive and protects it from malicious attack.

3.6 TRIM

TRIM is a SATA command that helps improve the read/write performance and efficiency of solid-state drives (SSD). The command enables the host operating system to inform SSD controller which blocks contain invalid data, mostly because of the erase commands from host. The invalid will be discarded permanently and the SSD will retain more space for itself.

3.7 SLC-lite Technology

SLC-lite is Apacer's proprietary technology that strikes a cost-performance balance between MLC and SLC flash types and it is an ideal alternative solution for mission-critical embedded or industrial applications. It utilizes the infrastructure of MLC flash together with the special firmware to simulate the performance and durability of industrial grade flash SLC, which enable the maximum endurance, retention and performance but lower cost.

4. Reliability Specifications

4.1 Environments

Table 4-1 Environmental Specifications

Environment		Specifications
Temperature	Operating	0°C to 70°C (Standard); -40°C to 85°C (Extended)
	Storage	-40°C to 85°C
Vibration		Non-operating: Sine wave, 15(G), 10~2000(Hz), Operating: Random, 7.69(Grms), 20~2000(Hz)
Shock		Non-operating: Acceleration, 1,500 G, 0.5 ms Operating: Peak acceleration, 50 G, 11 ms

Note: Shock and Vibration specifications are subject to change without notice.

4.2 Mean Time Between Failures (MTBF)

Mean Time Between Failures (MTBF) is predicted based on reliability data for the individual components in SFD drive. The prediction result for SU130-25 is more than 1,000,000 hours.

Note: The MTBF is predicated and calculated based on “Telcordia Technologies Special Report, SR-332, Issue 2” method.

4.3 Certification and Compliance

- CE
- FCC
- RoHS

4.4 Endurance

The endurance of a storage device is predicted by TeraBytes Written based on several factors related to usage, such as the amount of data written into the drive, block management conditions, and daily workload for the drive. Thus, key factors, such as Write Amplifications and the number of P/E cycles, can influence the lifespan of the drive.

Capacity	TeraBytes Written
512 GB	5,300

Note:

- The measurement assumes the data written to the SSD for test is under a typical and constant rate.
- The measurement follows the standard metric: 1 TB (Terabyte) = 1,000 GB.
- This estimation complies with JEDEC JESD-219, enterprise endurance workload of random data with payload size distribution.

5. Electrical Characteristics

5.1 Operating Voltage

Table 5-1 lists the supply voltage for SU130-25.

Table 5-1 Operating Voltage

Parameter	Conditions
Supply voltage	5V \pm 5%

5.2 Power Consumption

Table 5-2 lists the power consumption SU130-25.

Table 5-2 Power Consumption

Capacity	512 GB
Performance	
Active (mA)	905
Idle (mA)	95

Note:

*All values are typical and may vary depending on flash configurations or host system settings.

**Active power is an average power measurement performed using CrystalDiskMark with 128KB sequential read/write transfers.

6. Mechanical Specifications

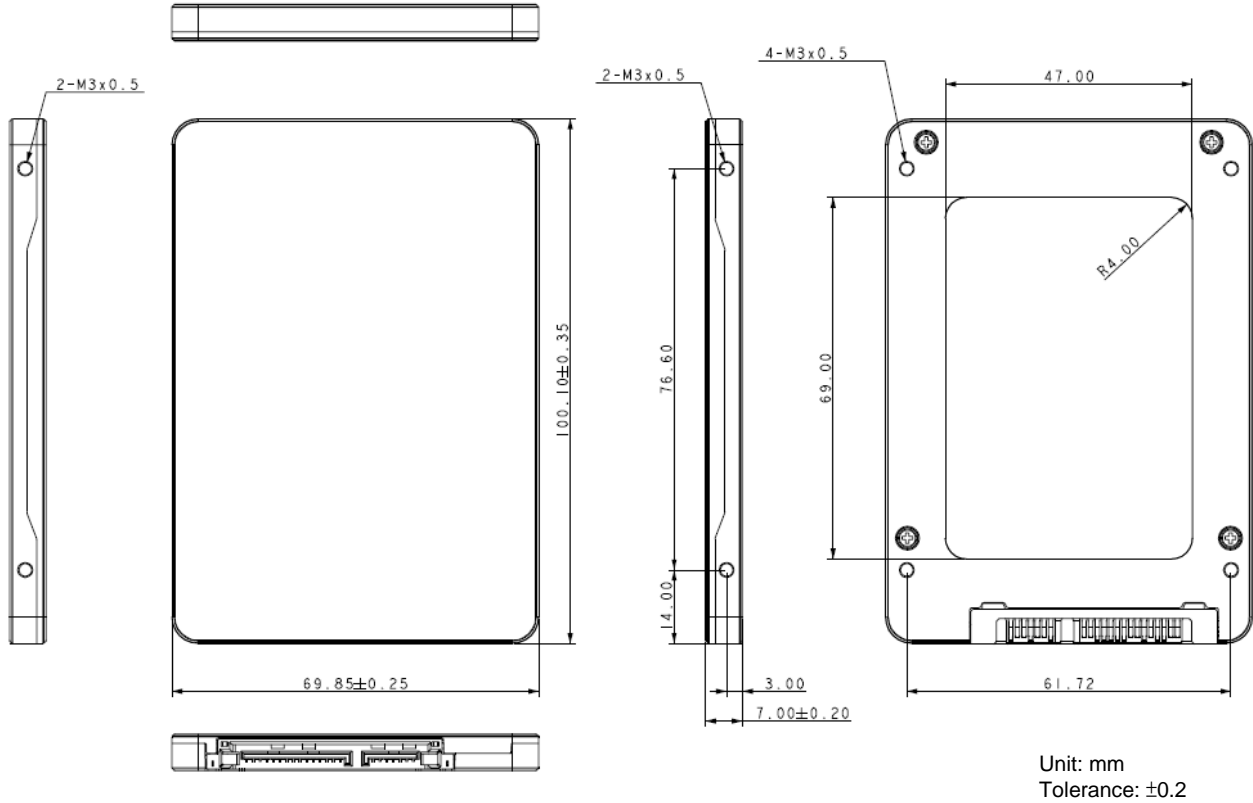

7. Product Ordering Information

7.1 Product Code Designation

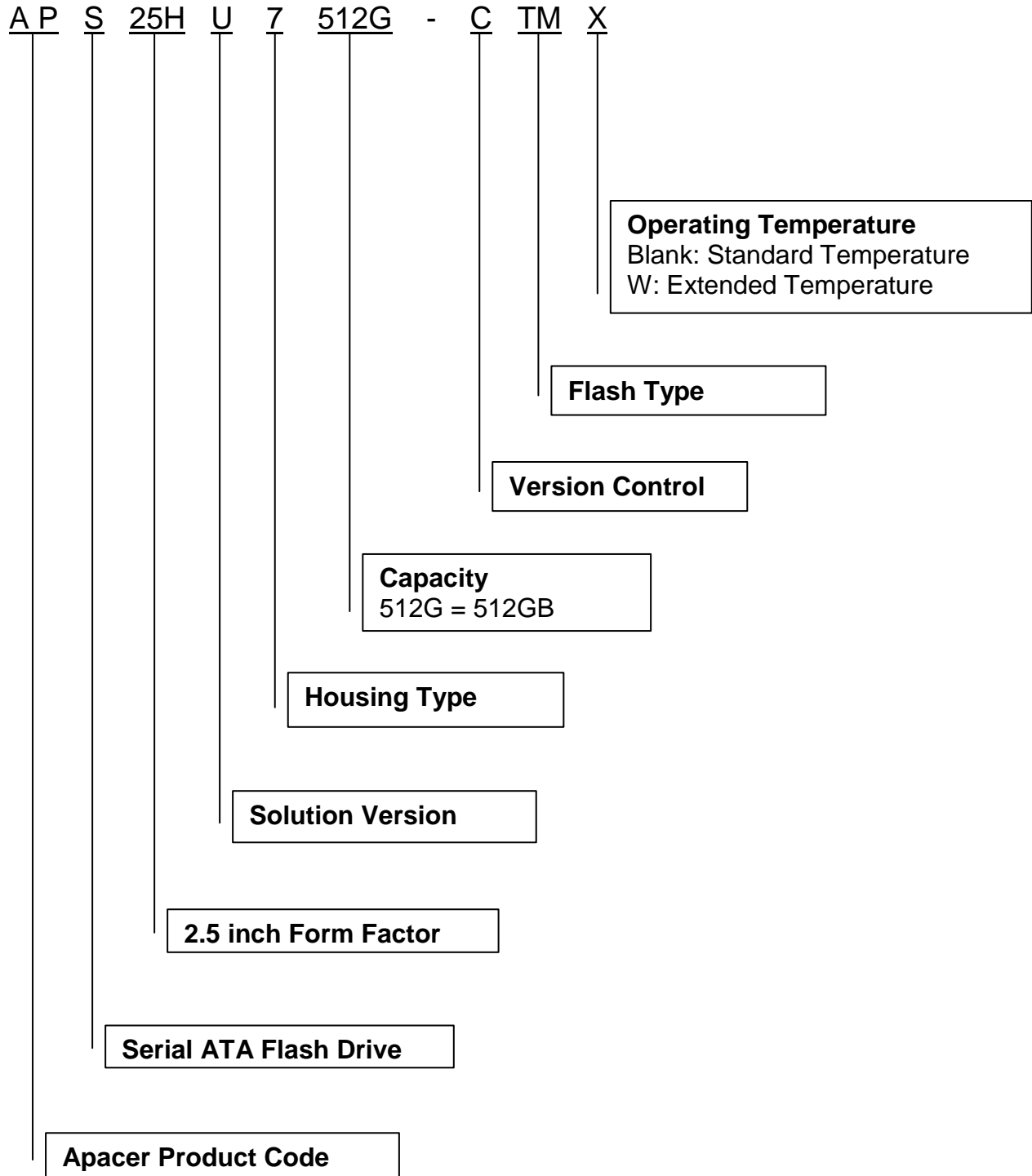

7.2 Valid Combinations

Capacity	Standard Temperature	Extended Temperature
512GB	APS25HU7512G-CTM	APS25HU7512G-CTMW

Note: Valid combinations are those products in mass production or will be in mass production. Consult your Apacer sales representative to confirm availability of valid combinations and to determine availability of new combinations.

Revision History

Revision	Description	Date
0.1	Preliminary release	11/2/2016
0.2	Updated product ordering information	4/20/2017
1.0	- Added Firmware Version and Endurance on Features page - Added 3.7 SLC-lite Technology and 4.4 Endurance	10/11/2017

Global Presence

Taiwan (Headquarters)	Apacer Technology Inc. 1F., No.32, Zhongcheng Rd., Tucheng Dist., New Taipei City 236, Taiwan R.O.C. Tel: 886-2-2267-8000 Fax: 886-2-2267-2261 amtsales@apacer.com
U.S.A.	Apacer Memory America, Inc. 46732 Lakeview Blvd., Fremont, CA 94538 Tel: 1-408-518-8699 Fax: 1-510-249-9551 sa@apacerus.com
Japan	Apacer Technology Corp. 5F, Matsura Bldg., Shiba, Minato-Ku Tokyo, 105-0014, Japan Tel: 81-3-5419-2668 Fax: 81-3-5419-0018 jpservices@apacer.com
Europe	Apacer Technology B.V. Science Park Eindhoven 5051 5692 EB Son, The Netherlands Tel: 31-40-267-0000 Fax: 31-40-290-0686 sales@apacer.nl
China	Apacer Electronic (Shanghai) Co., Ltd Room D, 22/FL, No.2, Lane 600, JieyunPlaza, Tianshan RD, Shanghai, 200051, China Tel: 86-21-6228-9939 Fax: 86-21-6228-9936 sales@apacer.com.cn
India	Apacer Technologies Pvt Ltd, Unit No.201, "Brigade Corner", 7 th Block Jayanagar, Yediyur Circle, Bangalore – 560082, India Tel: 91-80-4152-9061 Fax: 91-80-4170-0215 sales_india@apacer.com