

RoHS Compliant

Serial ATA Flash Drive

SFD25A -MK Product Specifications

May 23rd, 2014

Version 1.3



Apacer Technology Inc.

1F, No.32, Zhongcheng Rd., Tucheng Dist., New Taipei City, Taiwan, R.O.C

Tel: +886-2-2267-8000 Fax: +886-2-2267-2261

www.apacer.com

Features:

- **Compliance with SATA Revision 3.1**
 - Serial ATA Revision 3.1
 - SATA 6.0 Gbps interface
 - Backward compatible with SATA 1.5 and 3.0 Gbps interfaces
 - ATA-8 command set
- **Capacities**
 - 30, 60, 120, 240 GB
- **Performance***
 - Interface burst read/write: 600 MB/sec
 - Sustained read: up to 515 MB/sec
 - Sustained write: up to 285 MB/sec
 - Random read (4K): up to 69,000 IOPS
 - Random write (4K): up to 69,000 IOPS
- **Flash Management**
 - Built-in hardware ECC, enabling up to 40 bit correction per 1K bytes
 - Static/dynamic wear leveling
 - Flash bad-block management
 - S.M.A.R.T.
 - Power Failure Management
 - ATA Secure Erase
 - TRIM
- **NAND Flash Type: MLC**
- **Temperature ranges**
 - Operating: 0°C to 70°C
 - Storage: -40°C to 100°C
- **Supply voltage**
 - 5.0 V \pm 5%
- **Power consumption (typical)***
 - Active mode: 590 mA
 - Idle mode: 55 mA
- **Form factor**
 - 2.5"
 - Dimensions: 100.00 x 69.85 x 6.90, unit: mm
- **Connector**
 - 7-pin SATA signal connector
 - 15-pin SATA power connector
- **Shock & Vibration****
 - Shock: 1500 G
 - Vibration: 15 G
- **DRAM cache for enhanced random performance**
- **Device Sleep mode (optional)**
- **SATA power management modes**
- **RoHS compliant**

*The values addressed here are typical and may vary depending on settings and platforms.

**Non-operating

Table of Contents

| | |
|--|-----------|
| 1. Product Description | 3 |
| 1.1 Introduction | 3 |
| 1.2 Capacity Specification | 3 |
| 1.3 Performance..... | 3 |
| 1.4 Pin Assignments..... | 4 |
| 2. Software Interface | 6 |
| 2.1 Command Set | 6 |
| 2.2 S.M.A.R.T..... | 6 |
| 3. Flash Management | 8 |
| 3.1 Error Correction/Detection..... | 8 |
| 3.2 Bad Block Management | 8 |
| 3.3 Wear Leveling | 8 |
| 3.4 Power Failure Management..... | 8 |
| 3.5 ATA Secure Erase..... | 8 |
| 3.6 TRIM | 9 |
| 3.7 SATA Power Management | 9 |
| 4. Reliability Specifications | 10 |
| 4.1 Environmental | 10 |
| 4.2 Mean Time Between Failures (MTBF)..... | 10 |
| 4.3 Certification and Compliance | 10 |
| 5. Electrical Characteristics | 11 |
| 5.1 Operating Voltage | 11 |
| 5.2 Power Consumption | 11 |
| 6. Mechanical Specifications | 12 |
| 6.1 7mm Type Dimensions | 12 |
| 6.2 9.5mm Type Dimensions | 13 |
| 7. Product Ordering Information | 14 |
| 7.1 Product Code Designation..... | 14 |
| 7.2 Valid Combination..... | 15 |

1. Product Description

1.1 Introduction

Apacer's SFD25A-MK is a well-balanced solid-state disk (SSD) drive with standard form factor and great performance. Designed in SATA 6.0 Gbps interface, the SSD is able to deliver exceptional read/write speed, making it the ideal companion for heavy-loading industrial or server operations.

For data efficiency, the internal controlling unit of the SSD is engineered with DRAM for enhanced random performance. In regard of reliability, the drive comes with various implementations including powerful hardware ECC engine, power saving modes, wear leveling, flash block management, S.M.A.R.T., TRIM, and power failure management.

1.2 Capacity Specification

Table 1-1 Capacity specification

| Capacity | Total Bytes* | Cylinders | Heads | Sectors | Max LBA* |
|----------|-----------------|-----------|-------|---------|-------------|
| 30 GB | 30,016,659,456 | 16,383 | 16 | 63 | 58,626,288 |
| 60 GB | 60,022,480,896 | 16,383 | 16 | 63 | 117,231,408 |
| 120 GB | 120,034,123,776 | 16,383 | 16 | 63 | 234,441,648 |
| 240 GB | 240,057,409,536 | 16,383 | 16 | 63 | 468,862,128 |

*Display of total bytes varies from file systems.

**Cylinders, heads or sectors are not applicable for these capacities. Only LBA addressing applies.

LBA count addressed in the table above indicates total user storage capacity and will remain the same throughout the lifespan of the device. However, the total usable capacity of the SSD is most likely to be less than the total physical capacity because a small portion of the capacity is reserved for device maintenance usages.

1.3 Performance

Table 1-2 Performance

| Capacity \ Performance | 30 GB | 60 GB | 120 GB | 240 GB |
|-------------------------------|--------|--------|--------|--------|
| Sustained Read (MB/s) | 180 | 315 | 505 | 515 |
| Sustained Write (MB/s) | 38 | 75 | 135 | 285 |
| Random Read IOPS (4K) | 19,000 | 36,000 | 62,000 | 69,000 |
| Random Write IOPS (4K) | 9,000 | 18,000 | 33,000 | 69,000 |

Note: Performance varies from flash configurations or host system settings.

IOPS: measured on 8GB span (16777216 sectors Disk Size), 32 Outstanding I/Os (QD=32), Full Random Data pattern, 4KB Align I/Os and test durations 15minutes.

1.4 Pin Assignments

Table 1-3 describes the SFD signal segment, and Table 1-4, power segment.

Figure 1-2 SATA Connectors

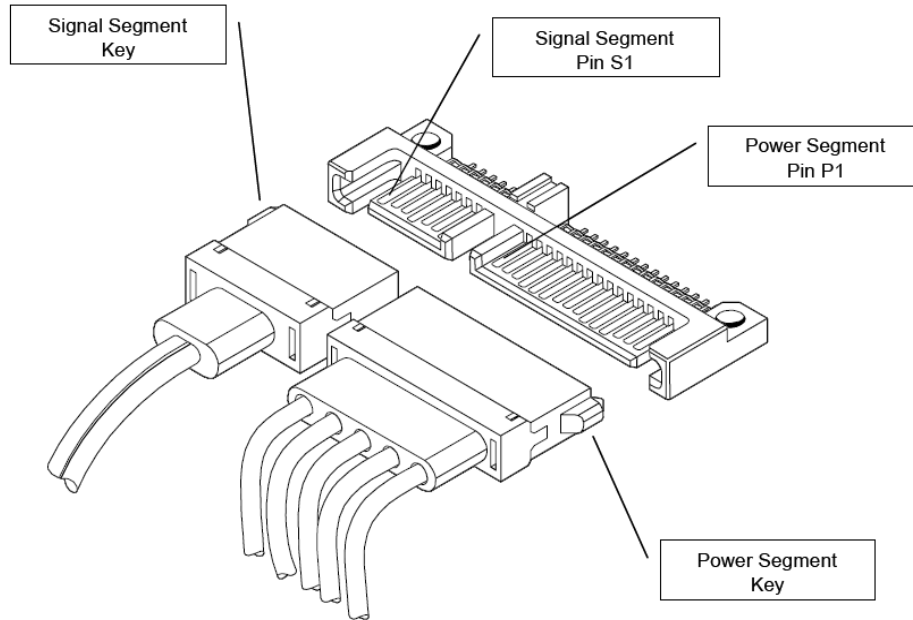

Table 1-3: Signal segment

| Pin | Type | Description |
|-----|------|--------------------------------|
| S1 | GND | |
| S2 | RxP | + Differential Receive Signal |
| S3 | RxN | - Differential Receive Signal |
| S4 | GND | |
| S5 | TxN | - Differential Transmit Signal |
| S6 | TxP | + Differential Transmit Signal |
| S7 | GND | |

Table 1-4: Power segment

| Pin | Signal/Description |
|-----|-------------------------------|
| P1 | Unused (3.3V) |
| P2 | Unused (3.3V) |
| P3 | Unused (3.3V) or Device Sleep |
| P4 | Ground |
| P5 | Ground |
| P6 | Ground |
| P7 | 5V |
| P8 | 5V |
| P9 | 5V |
| P10 | Ground |
| P11 | DAS |
| P12 | Ground |
| P13 | Unused (12V) |
| P14 | Unused (12V) |
| P15 | Unused (12V) |

*P3 can be configured as Device Sleep trigger pin

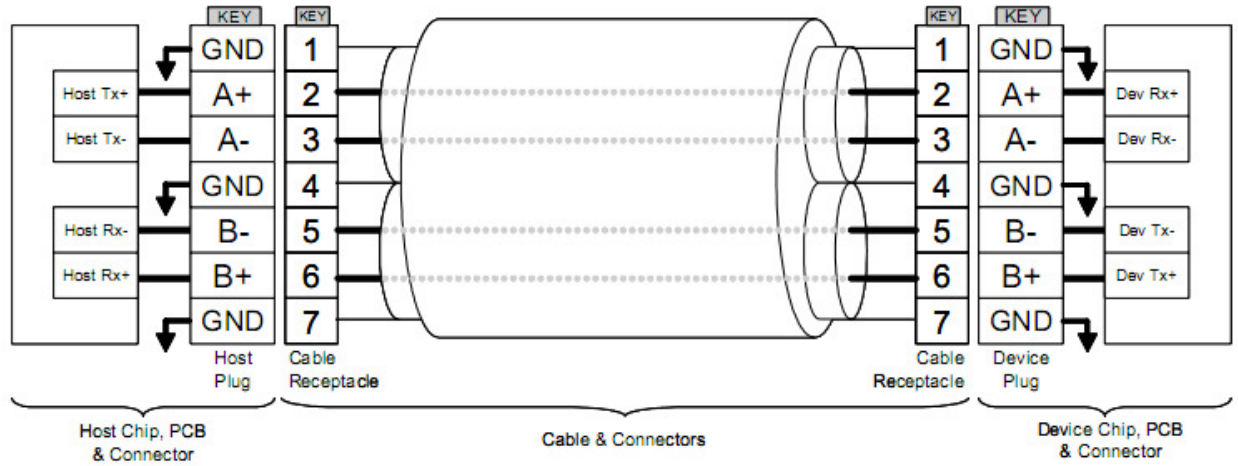

Figure 1-3 SATA Cable/Connector Connection Diagram

The connector on the left represents the Host with TX/RX differential pairs connected to a cable. The connector on the right shows the Device with TX/RX differential pairs also connected to the cable. Notice also the ground path connecting the shielding of the cable to the Cable Receptacle.

2. Software Interface

2.1 Command Set

Table 2-1 summarizes the ATA commands supported by SFD25A-MK.

Table 2-1: Command set

| Code | Command | Code | Command |
|-----------|------------------------------|------------|---------------------------|
| E5h | Check Power Mode | F6h | Security Disable Password |
| 90h | Execute Diagnostics | F3h | Security Erase Prepare |
| E7h | Flush Cache | F4h | Security Erase Unit |
| ECh | Identify Device | F5h | Security Freeze Lock |
| E3h | Idle | F1h | Security Set Password |
| E1h | Idle Immediate | F2h | Security Unlock |
| 91h | Initialize Device Parameters | 7xh | Seek |
| C8h | Read DMA | Efh | Set Features |
| 25h | Read DMA EXT | C6h | Set Multiple Mode |
| 60h | Read FPDMA Queued | E6h | Sleep |
| 47h | Read Log DMA EXT | B0h | S.M.A.R.T. |
| 2Fh | Read Log EXT | E2h | Standby |
| C4h | Read Multiple | E0h | Standby Immediate |
| 20 or 21h | Read Sector(s) | Cah | Write DMA |
| 40 or 41h | Read Verify Sector(s) | 35h | Write DMA EXT |
| 10h | Recalibrate | 61h | Write FPDMA Queued |
| 57h | Write Log DMA EXT | 3Fh | Write Log EXT |
| C5h | Write Multiple | 30h or 31h | Write Sector(s) |

2.2 S.M.A.R.T.

S.M.A.R.T. is an abbreviation for Self-Monitoring, Analysis and Reporting Technology, a self-monitoring system that provides indicators of drive health as well as potential disk problems. It serves as a warning for users from unscheduled downtime by monitoring and displaying critical drive information. Ideally, this should allow taking proactive actions to prevent drive failure and make use of S.M.A.R.T. information for future product development reference.

Apacer devices use the standard SMART command B0h to read data out from the drive to activate our S.M.A.R.T. feature that complies with the ATA/ATAPI specifications. S.M.A.R.T. Attribute IDs shall include initial bad block count, total later bad block count, maximum erase count, average erase count, power on hours and power cycle. When the S.M.A.R.T. Utility running on the host, it analyzes and reports the disk status to the host before the device reaches in critical condition.

Note: attribute IDs may vary from product models due to various solution design and supporting capabilities.

Serial ATA Flash Drive

APS25AXXxxxx-2XXM



Apacer memory products come with S.M.A.R.T. commands and subcommands for users to obtain information of drive status and to predict potential drive failures. Users can take advantage of the following commands/subcommands to monitor the health of the drive.

| Code | SMART Subcommand |
|------|-----------------------------------|
| D0h | READ DATA |
| D1h | READ ATTRIBUTE THRESHOLDS |
| D2h | Enable/Disable Attribute Autosave |
| D4h | Execute Off-line Immediate |
| D5h | Read Log (optional) |
| D6h | Write Log (optional) |
| D8h | Enable Operations |
| D9h | Disable operations |
| Dah | Return Status |

General SMART attribute structure

| Byte | Description |
|-------|-------------|
| 0 | ID (Hex) |
| 1 – 2 | Status flag |
| 3 | Value |
| 4 | Worst |
| 5*-11 | Raw Data |

*Byte 5: LSB

SMART attribute ID list

| ID (Hex) | Attribute Name |
|------------|------------------------------------|
| 9 (0x09) | Power-on hours |
| 12 (0x0C) | Power cycle count |
| 163 (0xA3) | Max. erase count |
| 164 (0xA4) | Avg. erase count |
| 166 (0xA6) | Total later bad block count |
| 167 (0xA7) | SSD Protect Mode (vendor specific) |
| 168 (0xA8) | SATA PHY Error Count |
| 175 (0xAF) | Bad Cluster Table Count |
| 192 (0xC0) | Unexpected Power Loss Count |
| 194 (0xC2) | Temperature |
| 241 (0xF1) | Total sectors of write |

3. Flash Management

3.1 Error Correction/Detection

SFD25A-MK implements a hardware ECC scheme, based on the BCH algorithm. It can detect and correct up to 40 bits error in 1K bytes.

3.2 Bad Block Management

Current production technology is unable to guarantee total reliability of NAND flash memory array. When a flash memory device leaves factory, it comes with a minimal number of initial bad blocks during production or out-of-factory as there is no currently known technology that produce flash chips free of bad blocks. In addition, bad blocks may develop during program/erase cycles. When host performs program/erase command on a block, bad block may appear in Status Register. Since bad blocks are inevitable, the solution is to keep them in control. Apacer flash devices are programmed with ECC, block mapping technique and S.M.A.R.T to reduce invalidity or error. Once bad blocks are detected, data in those blocks will be transferred to free blocks and error will be corrected by designated algorithms.

3.3 Wear Leveling

Flash memory devices differ from Hard Disk Drives (HDDs) in terms of how blocks are utilized. For HDDs, when a change is made to stored data, like erase or update, the controller mechanism on HDDs will perform overwrites on blocks. Unlike HDDs, flash blocks cannot be overwritten and each P/E cycle wears down the lifespan of blocks gradually. Repeatedly program/erase cycles performed on the same memory cells will eventually cause some blocks to age faster than others. This would bring flash storages to their end of service term sooner. Wear leveling is an important mechanism that level out the wearing of blocks so that the wearing-down of blocks can be almost evenly distributed. This will increase the lifespan of SSDs. Commonly used wear leveling types are Static and Dynamic.

3.4 Power Failure Management

Power Failure Management plays a crucial role when experiencing unstable power supply. Power disruption may occur when users are storing data into the SSD. In this urgent situation, the controller would run multiple write-to-flash cycles to store the metadata for later block rebuilding. This urgent operation requires about several milliseconds to get it done. At the next power up, the firmware will perform a status tracking to retrieve the mapping table and resume previously programmed NAND blocks to check if there is any incompleteness of transmission.

Note: The controller unit of this product model is designed with a DRAM as a write cache for improved performance and data efficiency. Though unlikely to happen in most cases, the data cached in the volatile DRAM might be potentially affected if a sudden power loss takes place before the cached data is flushed into non-volatile NAND flash memory.

3.5 ATA Secure Erase

ATA Secure Erase is an ATA disk purging command currently embedded in most of the storage drives. Defined in ATA specifications, (ATA) Secure Erase is part of Security Feature Set that allows storage drives to erase all user data areas. The erase process usually runs on the firmware level as most of the ATA-based storage media currently in the market are built-in with this command. ATA Secure Erase can securely wipe out the user data in the drive and protects it from malicious attack.

3.6 TRIM

TRIM is a SATA command that helps improve the read/write performance and efficiency of solid-state drives (SSD). The command enables the host operating system to inform SSD controller which blocks contain invalid data, mostly because of the erase commands from host. The invalid will be discarded permanently and the SSD will retain more space for itself.

3.7 SATA Power Management

By complying with SATA 6.0 Gb/s specifications, the SSD supports the following SATA power saving modes:

- ACTIVE: PHY ready, full power, Tx & Rx operational
- PARTIAL: Reduces power, resumes in under 10 μ s (microseconds)
- SLUMBER: Reduces power, resumes in under 10 ms (milliseconds)
- HIPM: Host-Initiated Power Management
- DIPM: Device-Initiated Power Management
- AUTO-SLUMBER: Automatic transition from partial to slumber.
- Device Sleep (DevSleep or DEVSLP): PHY powered down; power consumption \leq 5 mW; host assertion time \leq 10 ms; exit timeout from this state \leq 20 ms (unless specified otherwise in SATA Identify Device Log).

Note:

1. The behaviors of power management features would depend on host/device settings.
2. Device Sleep mode is optional, depending on product ordering selections.

4. Reliability Specifications

4.1 Environmental

SFD25A-MK environmental specifications follow MIL-STD-810F, as indicated in the following table.

Table 4-1 SFD25A-MK environmental specifications

| Environment | Specification |
|-------------|---|
| Temperature | 0°C to 70°C (Operating) |
| | -40°C to 100°C (Non-operating) |
| Vibration | Non-operating : Sine wave, 15(G), 10~2000(Hz), Operating : Random, 7.69(Grms), 20~2000(Hz) |
| Shock | Non-operating: Acceleration, 1,500 G, 0.5 ms Operating: Peak acceleration, 50 G, 11 ms |

4.2 Mean Time Between Failures (MTBF)

Mean Time Between Failures (MTBF) is predicted based on reliability data for the individual components in SFD drive. The prediction result for the SFD25A-MK is more than 1,000,000 hours.

Notes about the MTBF:

The MTBF is predicated and calculated based on "Telcordia Technologies Special Report, SR-332, Issue 2" method.

4.3 Certification and Compliance

SFD25A-MK complies with the following standards:

- CE
- FCC
- RoHS
- MIL-STD-810F

5. Electrical Characteristics

5.1 Operating Voltage

Table 5-1 lists the supply voltage for SFD25A-MK.

Table 5-1 SFD25A-MK operating voltage

| Parameter | Conditions |
|----------------|----------------------------|
| Supply voltage | 5V \pm 5% (4.75-5.25 V) |

5.2 Power Consumption

Table 5-2 Power consumption

| Mode \ Capacity | 30 GB | 60 GB | 120 GB | 240 GB |
|-----------------|-------------|-------|--------|--------|
| | Active (mA) | 185 | 240 | 345 |
| Idle (mA) | 50 | 50 | 50 | 55 |

Note: Power consumptions may vary depending on settings and platforms.

6. Mechanical Specifications

6.1 7mm Type Dimensions

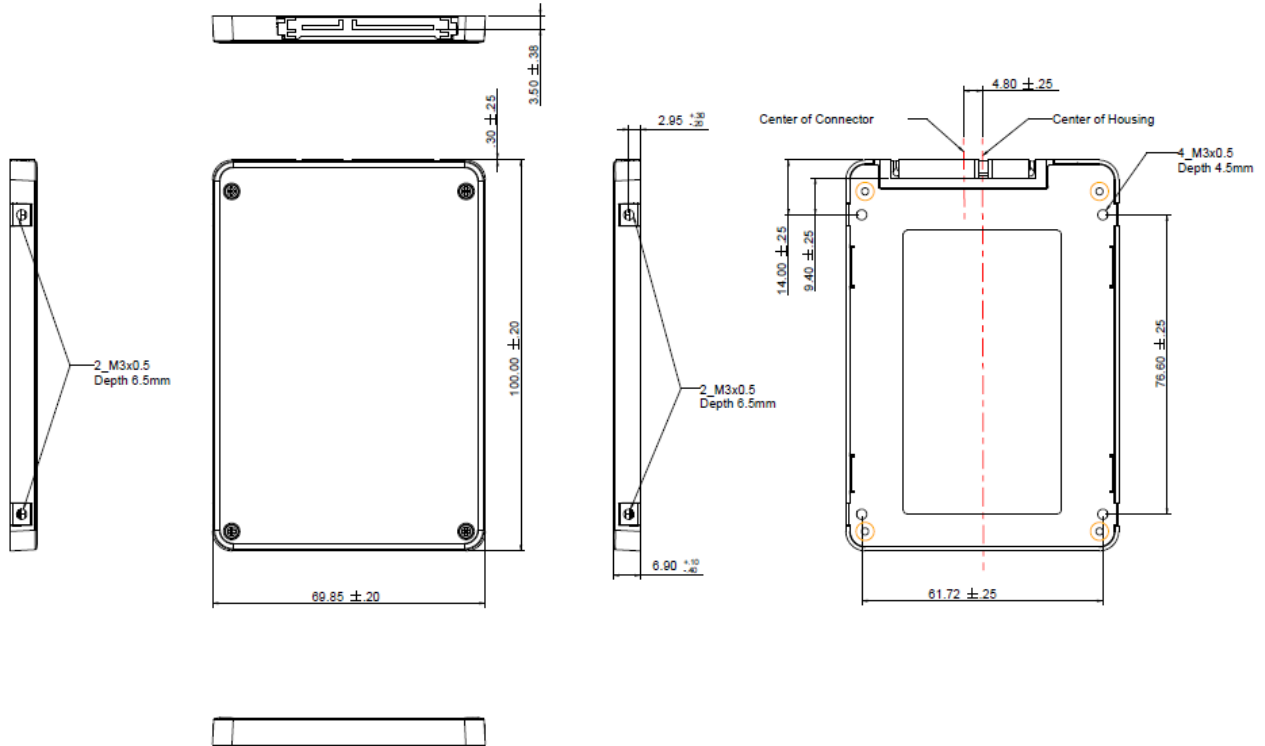

Unit: mm
Tolerance: ± 0.2

Figure 6-1 SFD25A-M with 7mm Housing physical dimensions

6.2 9.5mm Type Dimensions

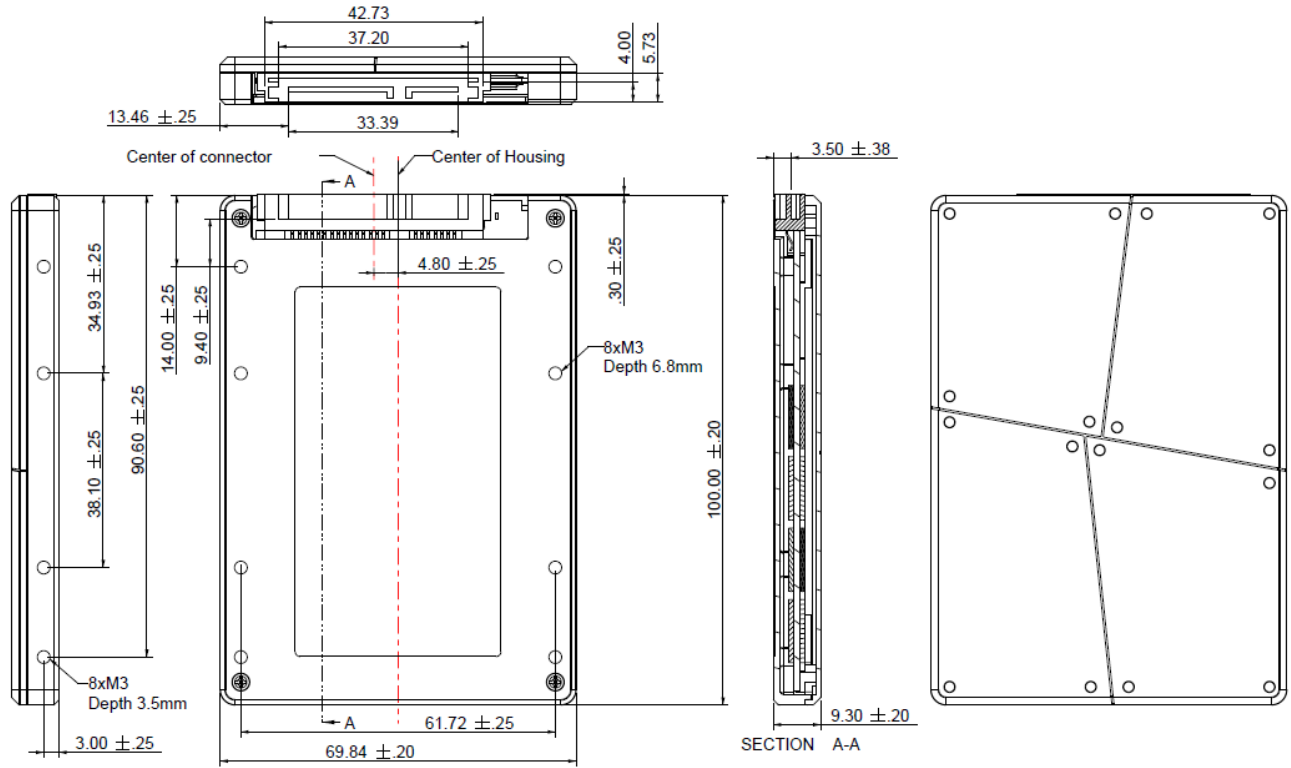

Unit: mm
 Tolerance: ± 0.2

Figure 6-2 SFD25A-M with 9.5mm Housing physical dimensions

7. Product Ordering Information

7.1 Product Code Designation

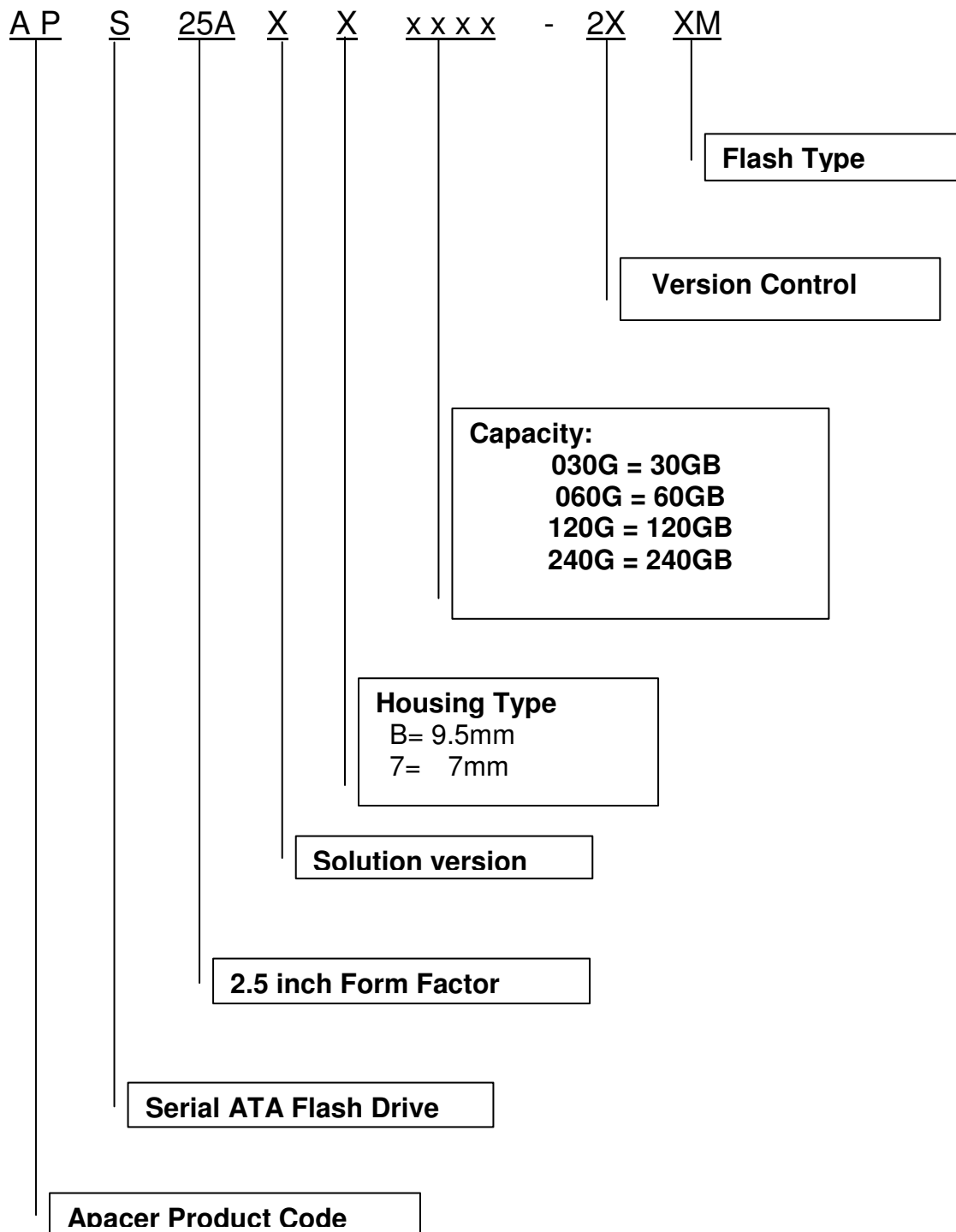

7.2 Valid Combination

7.2.1 9.5mm Metal Housing

| Capacity | NO DEVSLP | DEVSLP |
|----------|-------------------|-------------------|
| 30GB | APS25A4B030G-2ACM | APS25A4B030G-2BCM |
| 60GB | APS25A7B060G-2ACM | APS25A7B060G-2BCM |
| 120GB | APS25A7B120G-2ALM | APS25A7B120G-2BLM |
| 240GB | APS25A7B240G-2ALM | APS25A7B240G-2BLM |

7.2.2 7mm Housing

| Capacity | NO DEVSLP | DEVSLP |
|----------|-------------------|-------------------|
| 30GB | APS25A47030G-2ACM | APS25A47030G-2BCM |
| 60GB | APS25A77060G-2ACM | APS25A77060G-2BCM |
| 120GB | APS25A77120G-2ALM | APS25A77120G-2BLM |
| 240GB | APS25A77240G-2ALM | APS25A77240G-2BLM |

Note: Please consult with Apacer sales representatives for availabilities.

Revision History

| Revision | Description | Date |
|----------|---|------------|
| 0.1 | Preliminary release | 02/18/2014 |
| 0.2 | Added performance for 60GB, 120GB and 240GB models | 03/10/2014 |
| 0.3 | Revised the 60GB performance | 03/11/2014 |
| 1.0 | Official release | 03/27/2014 |
| 1.1 | Updated product ordering information due to change in NAND flash use for 30GB and 60 GB | 04/17/2014 |
| 1.2 | Revised performance information | 05/21/2014 |
| 1.3 | Revised product ordering information | 05/23/2014 |

Global Presence

Taiwan (Headquarters)

Apacer Technology Inc.
1F., No.32, Zhongcheng Rd., Tucheng Dist.,
New Taipei City 236, Taiwan R.O.C.
Tel: 886-2-2267-8000
Fax: 886-2-2267-2261
amtsales@apacer.com

U.S.A.

Apacer Memory America, Inc.
386 Fairview Way, Suite102,
Milpitas, CA 95035
Tel: 1-408-518-8699
Fax: 1-408-935-9611
sa@apacerus.com

Japan

Apacer Technology Corp.
5F, Matsura Bldg., Shiba, Minato-Ku
Tokyo, 105-0014, Japan
Tel: 81-3-5419-2668
Fax: 81-3-5419-0018
jpservices@apacer.com

Europe

Apacer Technology B.V.
Science Park Eindhoven 5051 5692 EB Son,
The Netherlands
Tel: 31-40-267-0000
Fax: 31-40-267-0000#6199
sales@apacer.nl

China

Apacer Electronic (Shanghai) Co., Ltd
1301, No.251,Xiaomuqiao Road, Shanghai,
200032, China
Tel: 86-21-5529-0222
Fax: 86-21-5206-6939
sales@apacer.com.cn

India

Apacer Technologies Pvt Ltd,
535, 1st Floor, 8th cross, JP Nagar 3rd Phase,
Bangalore – 560078, India
Tel: 91-80-4152-9061
sales_india@apacer.com