

Halogen Free

Value Added* **SATA-Disk Module I*

Specifications for 7P/270D

August 2nd, 2013

Revision 1.3



Apacer Technology Inc.

1F, No.32, Zhongcheng Rd., Tucheng Dist., New Taipei City, Taiwan, R.O.C

Tel: +886-2-2267-8000 Fax: +886-2-2267-2261

www.apacer.com

Features:

- **Standard Serial ATA Interface**
 - SATA Revision 1.0 compliance
 - SATA 1.5 Gbps interface speed
 - ATA command set
- **Connector type**
 - 7-pin signal connector
 - 2-pin power connector or power cable depending on ordering options
- **Power consumption (typical)***
 - Supply voltage: 5V
 - Active mode: 196mA
 - Idle mode: 124mA
- **Performance***
 - Burst transfer rate: 150 MB/sec
 - Sustained read: Up to 29 MB/sec
 - Sustained write: Up to 13 MB/sec
- **Capacity**
 - 128, 256, 512 MB
 - 1, 2, 4, 8 GB
- **NAND Flash Type: SLC**
- **Temperature ranges**
 - Operation: 0°C to 70°C
 - Storage: -40°C to 100°C
- **Flash management**
 - Advanced wear-leveling algorithms
 - S.M.A.R.T. technology
 - Built-in hardware ECC
 - Flash block management
 - Power failure management
 - ATA Security Erase
- **Form factor**
 - SATA Disk Module (7-pin/270-degree)
- **Shock & Vibration****
 - Shock: 1,500 G
 - Vibration: 15 G
- **Halogen Free**

*Varies from capacities. The values addressed for Performance and Power consumptions are typical and may vary depending on settings and platforms.

**Non-operating

Table of Contents

| | |
|--|-----------|
| 1. GENERAL DESCRIPTION | 3 |
| 2. FUNCTIONAL BLOCK | 3 |
| 3. PIN ASSIGNMENTS | 4 |
| 4. PRODUCT SPECIFICATIONS | 6 |
| 4.1 CAPACITY | 6 |
| 4.2 ATA MODES | 6 |
| 4.3 PERFORMANCE | 6 |
| 4.4 ENVIRONMENTAL SPECIFICATIONS | 7 |
| 5. FLASH MANAGEMENT | 8 |
| 5.1. ADVANCED WEAR-LEVELING ALGORITHMS | 8 |
| 5.2 S.M.A.R.T. TECHNOLOGY | 8 |
| 5.3 BUILT-IN HARDWARE ECC | 8 |
| 5.4 FLASH BLOCK MANAGEMENT | 8 |
| 5.5 POWER FAILURE MANAGEMENT..... | 8 |
| 5.6 ATA SECURITY ERASE | 9 |
| 6. SOFTWARE INTERFACE | 10 |
| 6.1 COMMAND SET | 10 |
| 7. ELECTRICAL SPECIFICATION | 12 |
| 8. PHYSICAL CHARACTERISTICS | 13 |
| 8.1 DIMENSION | 13 |
| 8.1.1 Power Cable Type..... | 13 |
| 8.1.2 Connector Pin Type | 15 |
| 9. PRODUCT ORDERING INFORMATION | 17 |
| 9.1 PRODUCT CODE DESIGNATIONS | 17 |
| 9.2 VALID COMBINATIONS | 18 |

1. General Description

Apacer's SATA-Disk Module (SDM) is a high-performance, embedded SSD DOM (Disk-on-module) designed to replace the conventional hard disk drive. SDM SSD can be plugged into a standard SATA connector commonly found in desktops, IT-STB, industrial PC and thin client systems. Moreover, Apacer provides an innovative way for design-in clients with limited spaces on their mainboard.

Apacer's SDM SSD has a built-in microcontroller with file management firmware that communicates with SATA standard interface. This product is well suited for embedded flash storage applications offering new and expanded functionalities as well as more cost-effective designs, better performance and increased reliability. SDM Series is designed to work at 5 volts and uses a standard SATA driver that complies with major operating systems such as the Windows series. Featuring technologies as Advanced Wear-leveling algorithms, S.M.A.R.T, flash block management, power failure management, and ATA Secure Erase, Apacer assures users of a versatile device on data storage.

2. Functional Block

The SATA-Disk Module (SDM) includes the SATA and Flash Management controllers, and flash media, as well as the SATA standard interface. Figure 2-1 shows the functional block diagram.

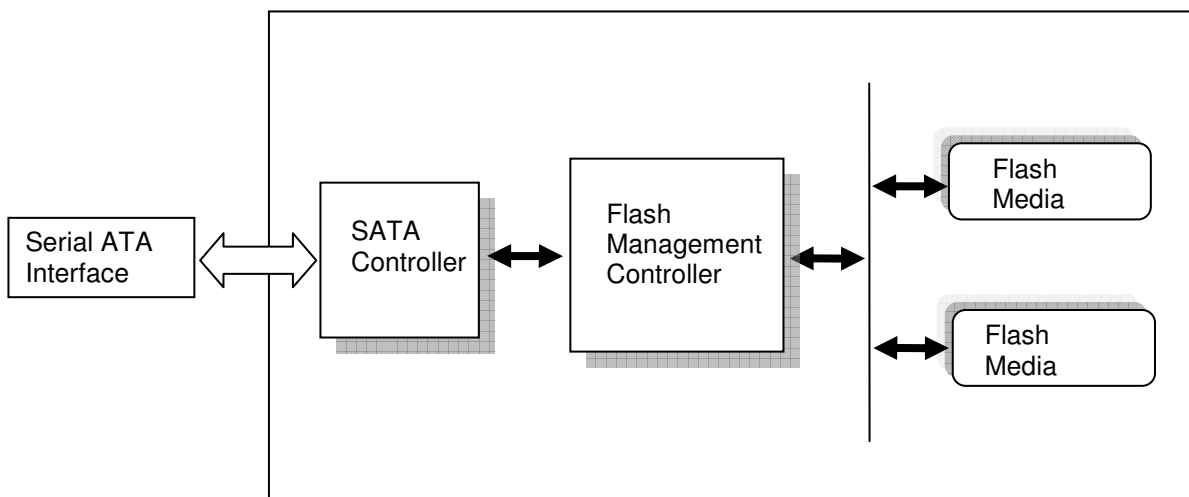

Figure 2-1: Functional block diagram

3. Pin Assignments

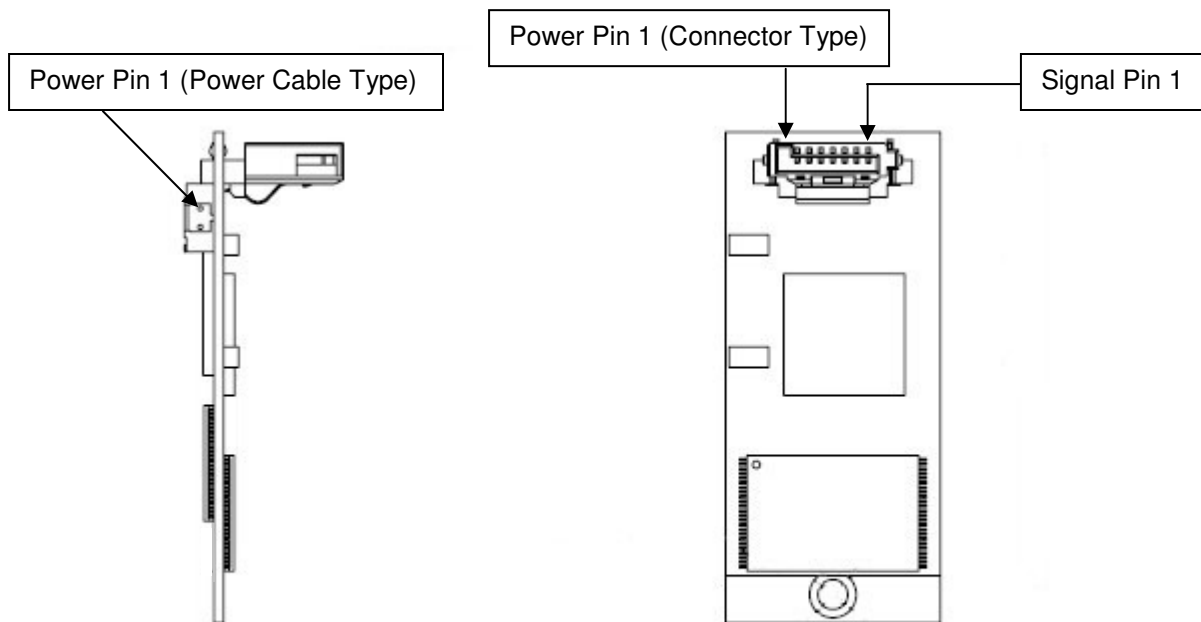

Table 3-1: Signal segment

| Pin | Type | Description |
|-----|------|--------------------------------|
| S1 | GND | |
| S2 | RxP | + Differential Receive Signal |
| S3 | RxN | - Differential Receive Signal |
| S4 | GND | |
| S5 | TxN | - Differential Transmit Signal |
| S6 | TxP | + Differential Transmit Signal |
| S7 | GND | |

Table 3-2: Power segment

| Pin | Signal/Description |
|-----|--------------------|
| P1 | VCC (5V) |
| P2 | GND |

Value Added SATA-Disk Module
AP-SDMxxxx8LANS-QTX

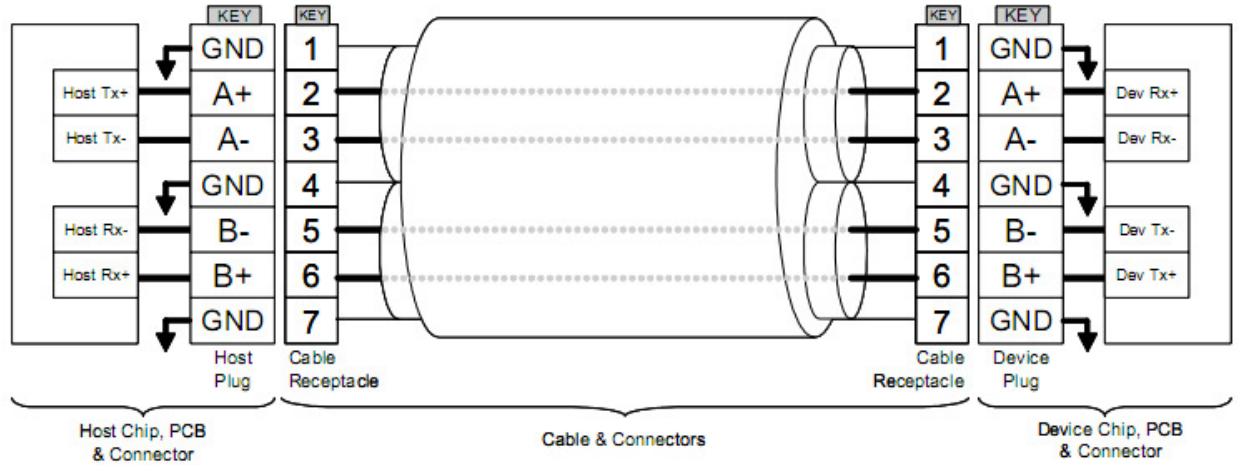

Figure 3-1 SATA Cable/Connector Connection Diagram

The connector on the left represents the Host with TX/RX differential pairs connected to a cable. The connector on the right shows the Device with TX/RX differential pairs also connected to the cable. Notice also the ground path connecting the shielding of the cable to the Cable Receptacle

4. Product Specifications

4.1 Capacity

Capacity specification of the SATA-Disk Module (SDM) product family is available as shown in Table 4-1.

Table 4-1: Capacity specifications

| Capacity | Total bytes* | Cylinders | Heads | Sectors | Max LBA |
|----------|---------------|-----------|-------|---------|------------|
| 128 MB | 128,057,344 | 977 | 8 | 32 | 250,112 |
| 256 MB | 256,901,120 | 980 | 16 | 32 | 501,760 |
| 512 MB | 512,483,328 | 993 | 16 | 63 | 1,000,944 |
| 1 GB | 1,024,966,656 | 1,986 | 16 | 63 | 2,001,888 |
| 2 GB | 2,048,385,024 | 3,969 | 16 | 63 | 4,000,752 |
| 4 GB | 4,096,253,952 | 7,937 | 16 | 63 | 8,000,496 |
| 8 GB | 8,001,552,384 | 15,504 | 16 | 63 | 15,628,032 |

*Display of total bytes varies from file systems. LBA count addressed in the table above indicates total user storage capacity and will remain the same throughout the lifespan of the device. However, the total usable capacity of the SSD is most likely to be less than the total physical capacity because a small portion of the capacity is reserved for device maintenance usages.

4.2 ATA Modes

The SATA Disk Module supports the following ATA operating modes:

- Supports up to PIO Mode-4
- Supports up to Multi-word DMA Mode-2
- Supports up to Ultra DMA Mode-4

4.3 Performance

Performances of SATA-Disk Modules are listed below in table 4-2.

Table 4-2: Performances

| Capacity | 128 MB | 256 MB | 512 MB | 1 GB | 2 GB | 4 GB | 8 GB |
|-------------------------------|--------|--------|--------|------|------|------|------|
| Performance | | | | | | | |
| Sustained read (MB/s) | 17 | 28 | 29 | 21 | 20 | 21 | 20 |
| Sustained write (MB/s) | 5 | 8 | 9 | 12 | 11 | 13 | 11 |

Note: Performances vary from host system configurations.

4.4 Environmental Specifications

Environmental specification of the SATA-Disk Module (SDM) product family follows the MIL-STD-810F standards as shown in Table 4-3.

Table 4-3: Environmental specifications

| Environment | | Specification |
|---------------------------|-----------|---|
| Temperature | Operation | 0 °C to 70 °C |
| | Storage | -40 °C to 100 °C |
| Vibration (Non-Operating) | | Sine wave: 10~2000Hz, 15G (X, Y, Z axes) |
| Shock (Non-Operating) | | Half sine wave, 1500 G, 0.5 ms (X, Y, Z ; All 6 axes) |

5. Flash Management

5.1. Advanced wear-leveling algorithms

Flash memory devices differ from Hard Disk Drives (HDDs) in terms of how blocks are utilized. For HDDs, when a change is made to stored data, like erase or update, the controller mechanism on HDDs will perform overwrites on blocks. Unlike HDDs, flash blocks cannot be overwritten and each P/E cycle wears down the lifespan of blocks gradually. Repeatedly program/erase cycles performed on the same memory cells will eventually cause some blocks to age faster than others. This would bring flash storages to their end of service term sooner. Wear leveling is an important mechanism that level out the wearing of blocks so that the wearing-down of blocks can be almost evenly distributed. This will increase the lifespan of SSDs. Commonly used wear leveling types are Static and Dynamic.

5.2 S.M.A.R.T. technology

S.M.A.R.T. is an acronym for Self-Monitoring, Analysis and Reporting Technology, an open standard allowing disk drives to automatically monitor their own health and report potential problems. It protects the user from unscheduled downtime by monitoring and storing critical drive performance and calibration parameters. Ideally, this should allow taking proactive actions to prevent impending drive failure. Apacer SMART feature adopts the standard SMART command B0h to read data from the drive. When the Apacer SMART Utility running on the host, it analyzes and reports the disk status to the host before the device is in critical condition.

5.3 Built-in hardware ECC

The SATA-Disk Module uses BCH Error Detection Code (EDC) and Error Correction Code (ECC) algorithms which correct up to eight random single-bit errors for each 512-byte block of data. High performance is fulfilled through hardware-based error detection and correction.

5.4 Flash block management

Current production technology is unable to guarantee total reliability of NAND flash memory array. When a flash memory device leaves factory, it comes with a minimal number of initial bad blocks during production or out-of-factory as there is no currently known technology that produce flash chips free of bad blocks. In addition, bad blocks may develop during program/erase cycles. When host performs program/erase command on a block, bad block may appear in Status Register. Since bad blocks are inevitable, the solution is to keep them in control. Apacer flash devices are programmed with ECC, block mapping technique and S.M.A.R.T to reduce invalidity or error. Once bad blocks are detected, data in those blocks will be transferred to free blocks and error will be corrected by designated algorithms.

5.5 Power Failure Management

Power Failure Management plays a crucial role when experiencing unstable power supply. Power disruption may occur when users are storing data into the SSD. In this urgent situation, the controller would run multiple write-to-flash cycles to store the metadata for later block rebuilding. This urgent operation requires about several milliseconds to get it done. At the next power up, the firmware will

perform a status tracking to retrieve the mapping table and resume previously programmed NAND blocks to check if there is any incompleteness of transmission.

5.6 ATA Security Erase

ATA Secure Erase is an ATA disk purging command currently embedded in most of the storage drives. Defined in ATA specifications, (ATA) Secure Erase is part of Security Feature Set that allows storage drives to erase all user data areas. The erase process usually runs on the firmware level as most of the ATA-based storage media currently in the market are built-in with this command. ATA Secure Erase can securely wipe out the user data in the drive and protects it from malicious attack.

6. Software Interface

6.1 Command Set

This section defines the software requirements and the format of the commands the host sends to the SATA-Disk Module (SDM). Commands are issued to the SDM by loading the required registers in the command block with the supplied parameters, and then writing the command code to the Command register.

Table 6-1: Command set (1 of 2)

| Command | Code |
|-----------------------------|------------|
| Check-Power-Mode | E5H or 98H |
| Execute-Drive-Diagnostic | 90H |
| Erase Sector(s) | C0H |
| Flush-Cache | E7H |
| Format Track | 50H |
| Identify-Drive | ECH |
| Idle | E3H or 97H |
| Idle-Immediate | E1H or 95H |
| Initialize-Drive-Parameters | 91H |
| NOP | 00H |
| Read-Buffer | E4H |
| Read-DMA | C8H or C9H |
| Read-Multiple | C4H |
| Read-Sector(s) | 20H or 21H |
| Read-Verify-Sector(s) | 40H or 41H |
| Recalibrate | 1XH |
| Request-Sense | 03H |
| Security-Disable-Password | F6H |
| Security-Erase-Prepare | F3H |
| Security-Erase-Unit | F4H |
| Security-Freeze-Lock | F5H |
| Security-Set-Password | F1H |
| Security-Unlock | F2H |
| Seek | 7XH |
| Set-Features | EFH |

Value Added **SATA-Disk Module1**
AP-SDMxxxx8LANS-QTX

Table 6-1: Command set (2 of 2)

| Command | Code |
|------------------------------|-------------|
| SMART | B0H |
| Set-Multiple-Mode | C6H |
| Set-Sleep-Mode | E6H or 99H |
| Standby | E2H or 96H |
| Standby-Immediate | E0H or 94H |
| Translate-Sector | 87H |
| Write-Buffer | E8H |
| Write-DMA | CAH or CBH |
| Write-Multiple | C5H |
| Write-Multiple-Without-Erase | CDH |
| Write-Sector(s) | 30H or 31H |
| Write-Sector-Without-Erase | 38H |
| Write-Verify | 3CH |

7. Electrical Specification

Caution: Absolute Maximum Stress Ratings – Applied conditions greater than those listed under “Absolute Maximum Stress Ratings” may cause permanent damage to the device. This is a stress rating only and functional operation of the device at these conditions or conditions greater than those defined in the operational sections of this data sheet is not implied. Exposure to absolute maximum stress rating conditions may affect device reliability.

Table 7-1: Operating range

| | |
|----------------------------|--------------|
| Ambient Temperature | 0°C to +70°C |
| Supply voltage | 4.75-5.25V |

Table 7-2: Absolute maximum power pin stress ratings

| Parameter | Symbol | Conditions |
|---|-----------------|---|
| Input Power | V _{DD} | -0.3V min. to 6.5V max. |
| Voltage on any pin except V _{DD} with respect to GND | V | -0.5V min. to V _{DD} + 0.5V max. |

Table 7-3: Recommended system power-up timing

| Symbol | Parameter | Typical | Maximum | Units |
|------------------------------------|-----------------------------|---------|---------|-------|
| T _{PU-READY} ¹ | Power-up to Ready Operation | 200 | 1000 | ms |
| T _{PU-WRITE} ¹ | Power-up to Write Operation | 200 | 1000 | ms |

1. This parameter is measured only for initial qualification and after a design or process change that could affect this parameter.

8. Physical Characteristics

8.1 Dimension

8.1.1 Power Cable Type

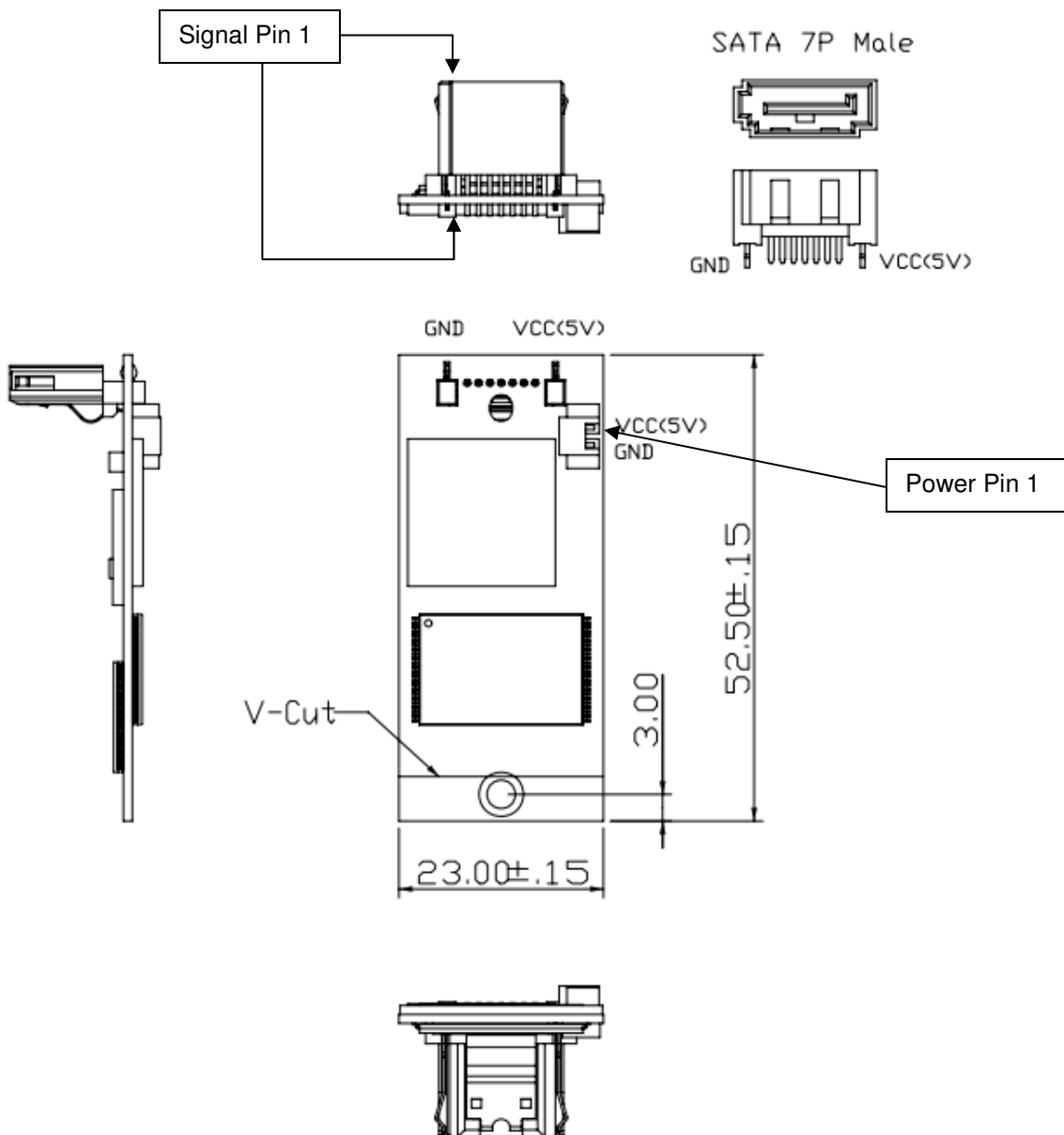

Unit: mm
Tolerance: ± 0.25

Value Added SATA-Disk Module
AP-SDMxxxx8LANS-QTX

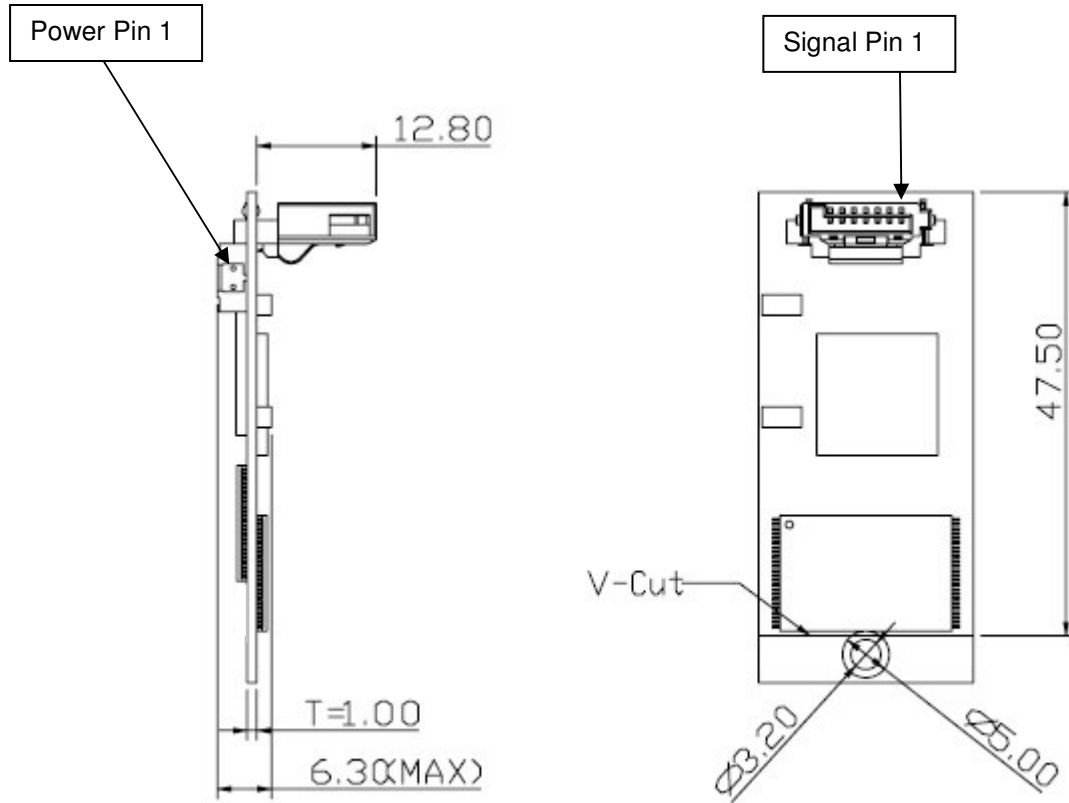

Unit: mm
Tolerance: ± 0.25

8.1.2 Connector Pin Type

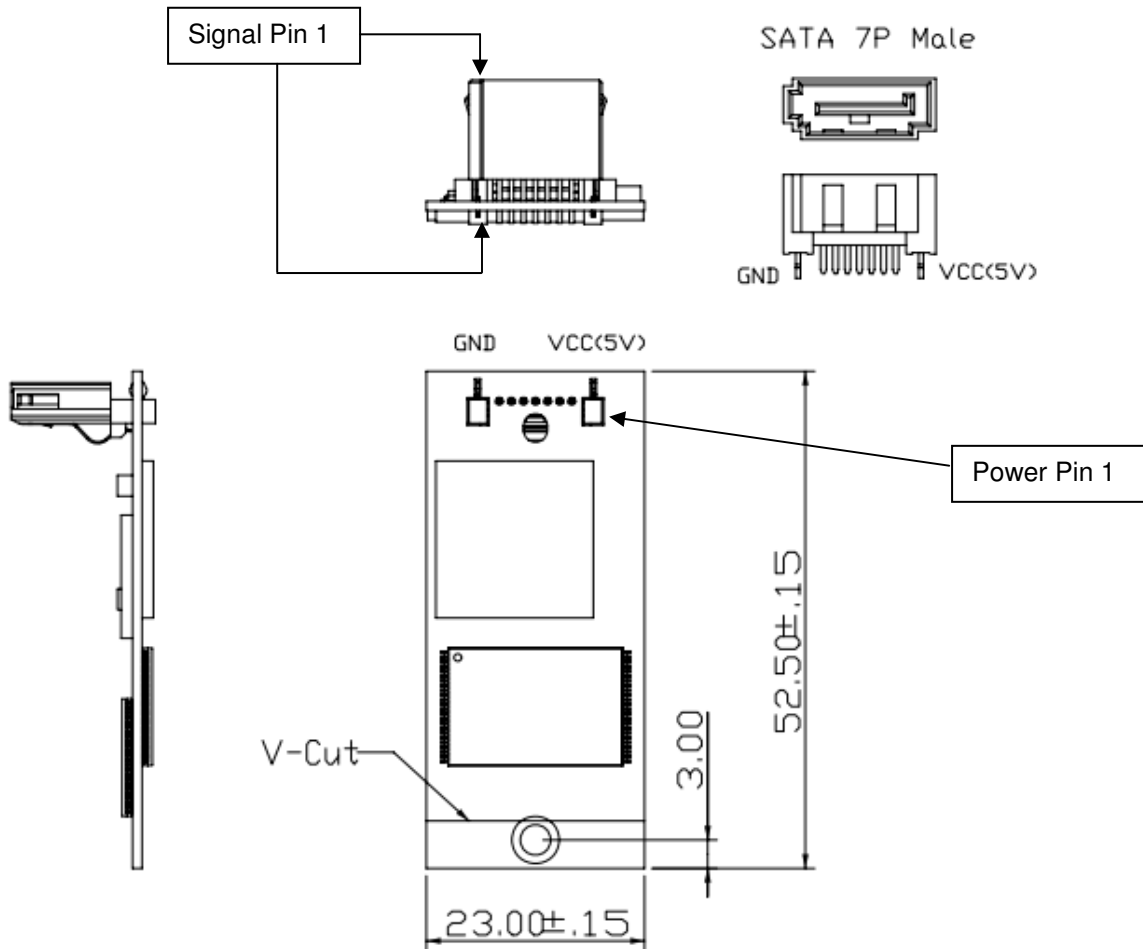

Note:

With the special SATA female connector, onboard SDM male socket accepts power-in from the certain host. Pay attention to short circuit when adopting cable design.

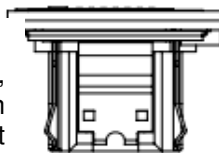

Value Added SATA-Disk Module
AP-SDMxxxx8LANS-QTX

Unit: mm
Tolerance: ± 0.25

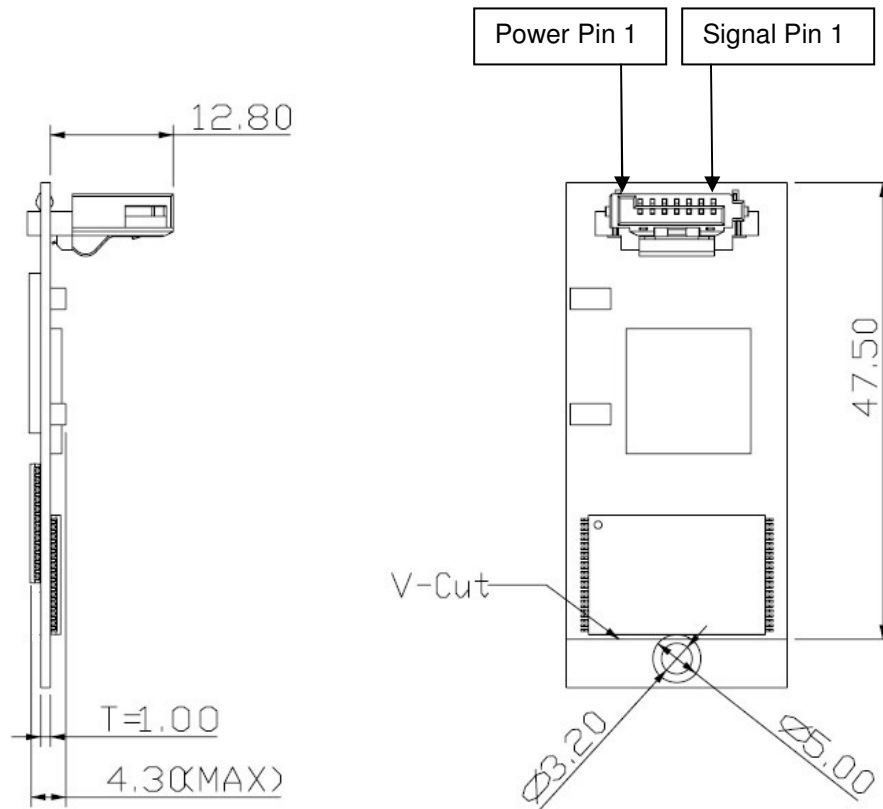

Unit: mm
Tolerance: ± 0.25

9. Product Ordering Information

9.1 Product Code Designations

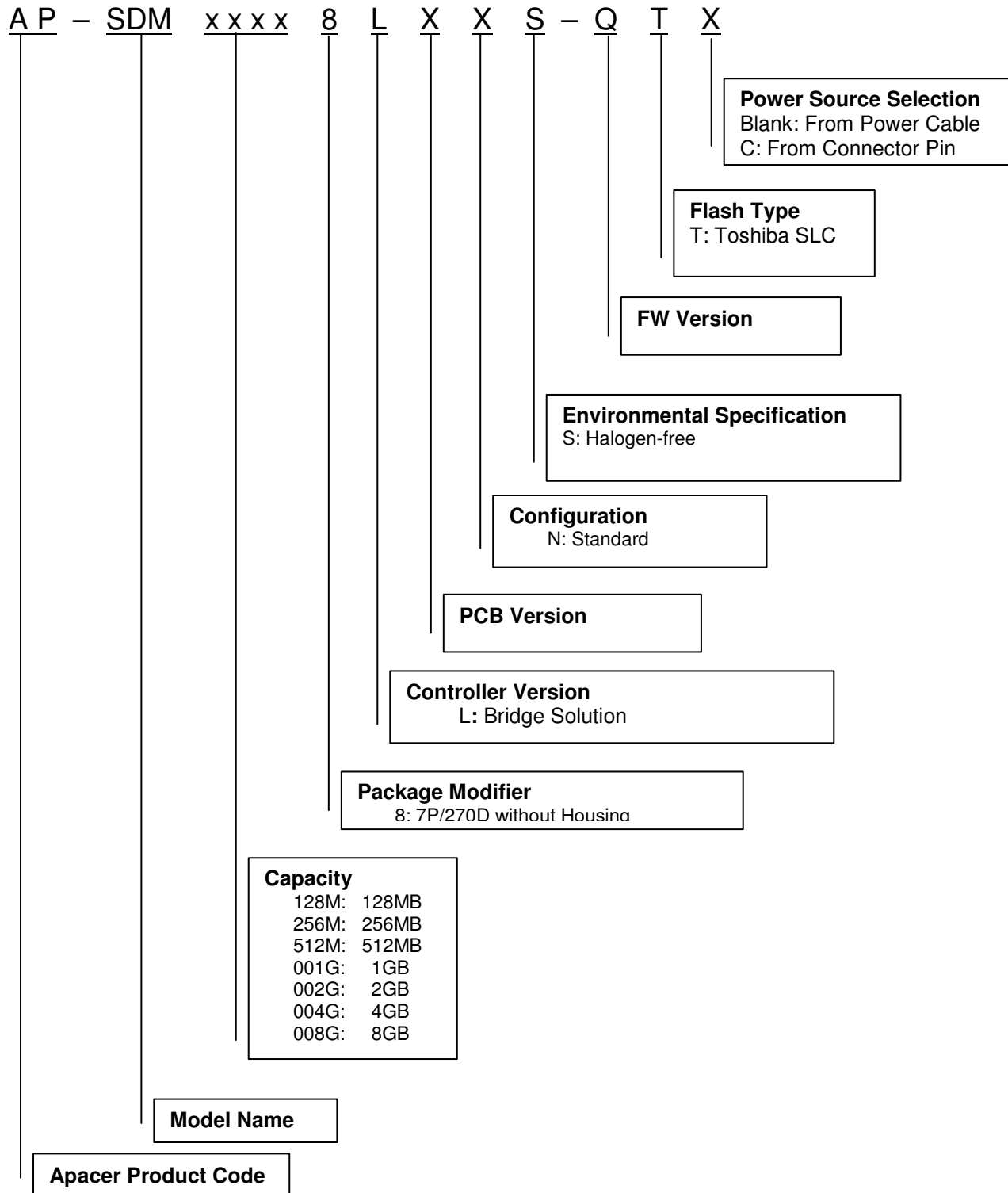

9.2 Valid Combinations

Power Cable Type

| Capacity | Standard |
|-----------------|--------------------|
| 128MB | AP-SDM128M8LANS-QT |
| 256MB | AP-SDM256M8LANS-QT |
| 512MB | AP-SDM512M8LANS-QT |
| 1GB | AP-SDM001G8LANS-QT |
| 2GB | AP-SDM002G8LANS-QT |
| 4GB | AP-SDM004G8LANS-QT |
| 8GB | AP-SDM008G8LANS-QT |

Connector Pin Type

| Capacity | Standard |
|-----------------|---------------------|
| 128MB | AP-SDM128M8LANS-QTC |
| 256MB | AP-SDM256M8LANS-QTC |
| 512MB | AP-SDM512M8LANS-QTC |
| 1GB | AP-SDM001G8LANS-QTC |
| 2GB | AP-SDM002G8LANS-QTC |
| 4GB | AP-SDM004G8LANS-QTC |
| 8GB | AP-SDM008G8LANS-QTC |

Revision History

| Revision | Date | Description | Remark |
|----------|------------|--|--------|
| 1.0 | 02/12/2009 | Official release | |
| 1.1 | 07/20/2009 | Updated drawings | |
| 1.2 | 03/01/2011 | Updated Product Ordering Information | |
| 1.3 | 08/02/2013 | Updated performance and product ordering information due to change in NAND flash use | |

Global Presence

| | |
|------------------------------|---|
| Taiwan (Headquarters) | Apacer Technology Inc. Apacer Technology Inc. 1F., No.32, Zhongcheng Rd., Tucheng Dist., New Taipei City 236, Taiwan R.O.C. Tel: 886-2-2267-8000 Fax: 886-2-2267-2261 amtsales@apacer.com |
| U.S.A. | Apacer Memory America, Inc. 386 Fairview Way, Suite102, Milpitas, CA 95035 Tel: 1-408-518-8699 Fax: 1-408-935-9611 sa@apacerus.com |
| Japan | Apacer Technology Corp. 5F, Matsura Bldg., Shiba, Minato-Ku Tokyo, 105-0014, Japan Tel: 81-3-5419-2668 Fax: 81-3-5419-0018 jpservices@apacer.com |
| Europe | Apacer Technology B.V. Science Park Eindhoven 5051 5692 EB Son, The Netherlands Tel: 31-40-267-0000 Fax: 31-40-267-0000#6199 sales@apacer.nl |
| China | Apacer Electronic (Shanghai) Co., Ltd 1301, No.251,Xiaomuqiao Road, Shanghai, 200032, China Tel: 86-21-5529-0222 Fax: 86-21-5206-6939 sales@apacer.com.cn |
| India | Apacer Technologies Pvt. Ltd. # 535, 1st Floor, 8th cross, JP Nagar 3rd Phase, Bangalore – 560078, India Tel: 91-80-4152-9061 sales_india@apacer.com |