

*RoHS Compliant*

# **SATA-Disk Module 4**

*SDM4-M 7P/90D Middle Profile Specifications*

November 4<sup>th</sup>, 2013

*Version 1.4*



***Apacer Technology Inc.***

1F, No.32, Zhongcheng Rd., Tucheng Dist., New Taipei City, Taiwan, R.O.C

Tel: +886-2-2267-8000 Fax: +886-2-2267-2261

[www.apacer.com](http://www.apacer.com)

## Features:

- **Standard Serial ATA Revision 2.6**
  - Compliance with SATA Revision 2.6 specifications
  - SATA 3.0 Gbps interface
  - ATA-compatible command set
- **Capacities**
  - 4, 8, 16, 32, 64 GB
- **Performance\***
  - Burst read/write: 300 MB/sec
  - Sustained read: up to 85 MB/sec
  - Sustained write: up to 43 MB/sec
- **Intelligent endurance design**
  - Built-in hardware ECC, enabling up to 16/24 bit correction per 1K bytes
  - Static/dynamic wear-leveling
  - Flash bad-block management
  - S.M.A.R.T.
  - Power Failure Management
  - ATA Secure Erase
  - TRIM
- **NAND Flash Type: MLC**
- **Temperature ranges**
  - Operation:
    - Standard: 0°C to 70°C (32 ~ 158°F)
    - Extended: -40°C to 85°C (-40° ~ 185°F)\*\*
  - Storage: -40°C to 100°C (-40° ~ 212°F)
- **Supply voltage**
  - 5.0 V ± 5%
- **Power consumption (typical)\***
  - Active mode: 225 mA@5.0 V
  - Idle mode: 83 mA@5.0 V
- **Connector type**
  - 7-pin signal connector
  - Power segment in two types: power cable and power cable-less types
- **Form factor**
  - Middle profile SATA Disk Module
  - Dimension: 58.0 x 24.0 x 1.0\*\*\*, unit: mm
- **Shock & Vibration\*\*\*\***
  - Shock: 1500 G
  - Vibration: 15 G
- **MTBF: >1,000,000 hours**
- **Write Protect (optional)**
  - Enabled by onboard hardware switch
- **RoHS compliant**

\*Varies from capacities. The values for performances and power consumptions presented are typical and may vary depending on flash configurations or platform settings. The term idle refers to the standby state of the device.

\*\*Only available in 8, 16 and 32GB models.

\*\*\*Implies to only the thickness of the module, without including the height/thickness of the connector head.

\*\*\*\*Non-operating

---

## Table of Contents

<b>1. GENERAL DESCRIPTION</b> .....	<b>3</b>
<b>2. FUNCTIONAL BLOCK</b> .....	<b>3</b>
<b>3. PIN ASSIGNMENTS</b> .....	<b>4</b>
<b>4. PRODUCT SPECIFICATION</b> .....	<b>6</b>
4.1 CAPACITY .....	6
4.2 PERFORMANCE .....	6
4.3 ENVIRONMENTAL SPECIFICATIONS .....	7
4.4 MEAN TIME BETWEEN FAILURES (MTBF) .....	7
4.5 CERTIFICATION AND COMPLIANCE .....	7
<b>5. FLASH MANAGEMENT</b> .....	<b>8</b>
5.1 ERROR CORRECTION/DETECTION .....	8
5.2 FLASH BLOCK MANAGEMENT .....	8
5.3 WEAR LEVELING .....	8
5.4 POWER FAILURE MANAGEMENT .....	8
5.5 ATA SECURE ERASE .....	8
5.6 S.M.A.R.T. ....	9
5.7 TRIM .....	9
<b>6. SOFTWARE INTERFACE</b> .....	<b>10</b>
6.1 COMMAND SET .....	10
<b>7. ELECTRICAL SPECIFICATION</b> .....	<b>11</b>
<b>8. PHYSICAL CHARACTERISTICS</b> .....	<b>12</b>
8.1 POWER CABLE TYPE .....	12
8.2 POWER CABLE-LESS TYPE .....	13
8.3 WRITE PROTECT SWITCH (OPTIONAL) .....	14
<b>9. PRODUCT ORDERING INFORMATION</b> .....	<b>15</b>
9.1 PRODUCT CODE DESIGNATIONS .....	15

## 1. General Description

Apacer's SATA-Disk Module 4 MLC version (SDM4-M) is a high-performance, embedded SSD DOM (Disk on Module) designed to replace the conventional SATA storage devices. SDM4-M can be fitted into a standard Serial ATA connectors commonly found in desktops, IT-STB, industrial PC and thin client systems. In addition, SDM4-M provides an innovative way for design-in clients with compact host computing systems.

Apacer's SDM4-M is built in with an efficient microcontroller that drives the potential of NAND flash and delivers optimal performance. With its compact form factor and SATA 3.0 Gbps interface, this product is well suited for embedded flash storage applications offering customizable and expanded functionalities as well as more cost-effective designs, better performance and increased reliability.

## 2. Functional Block

SDM4-M includes the SATA and Flash Management controllers, and flash media, as well as the SATA standard interface. Figure 2-1 shows the functional block diagram.

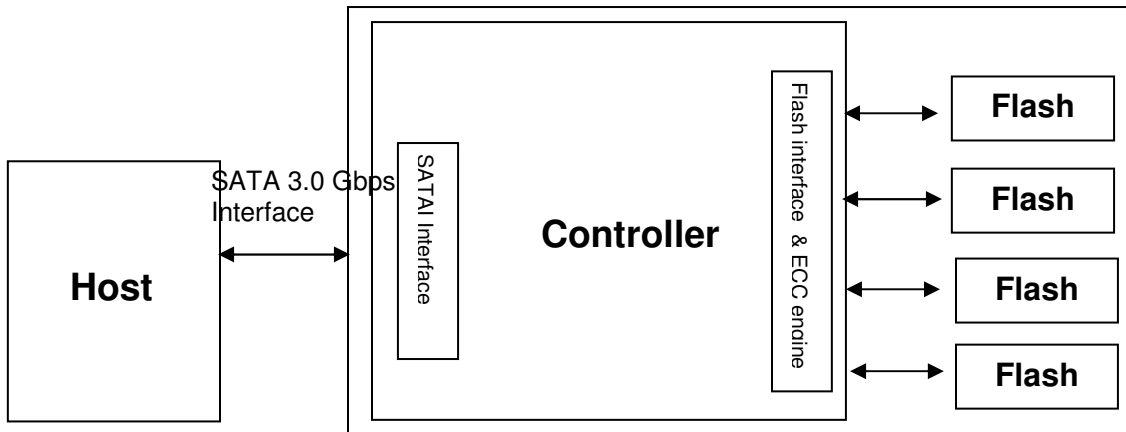

**Figure 2-1:** Functional block diagram

### 3. Pin Assignments

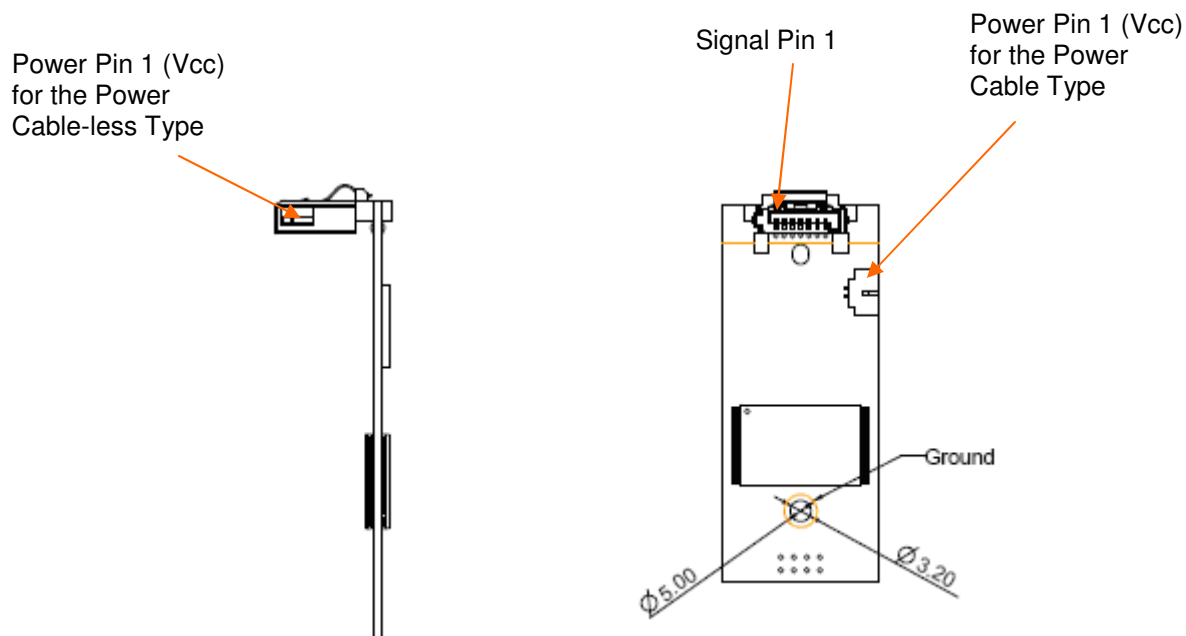
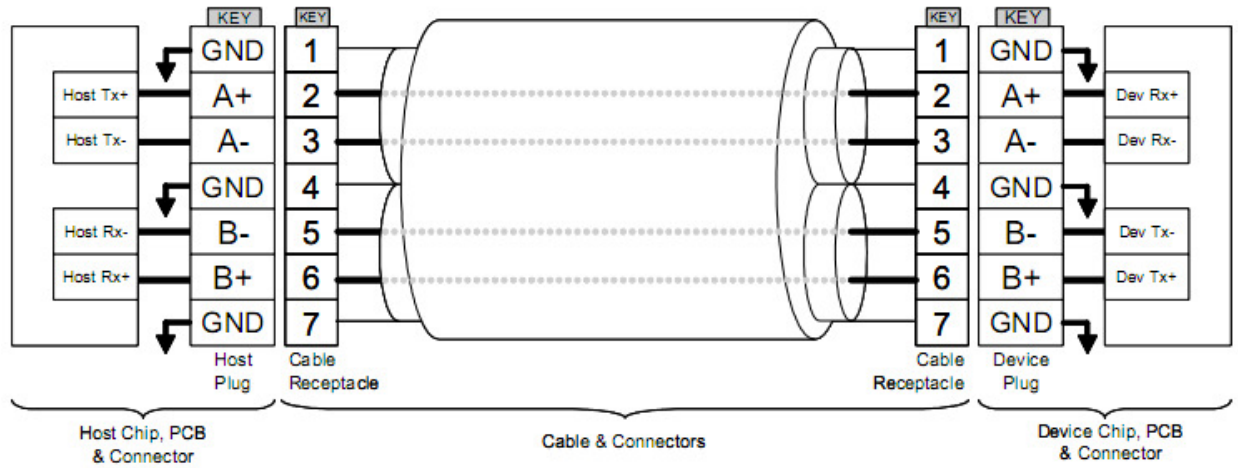

Table 3-1: Signal segment

Pin	Type	Description
Pin 1	GND	
Pin 2	RxP	+ Differential Receive Signal
Pin 3	RxN	- Differential Receive Signal
Pin 4	GND	
Pin 5	TxN	- Differential Transmit Signal
Pin 6	TxP	+ Differential Transmit Signal
Pin 7	GND	

Table 3-2: Power segment

Name	Description
Pin 1	VCC (5V)
Pin 2	GND



**Figure 3-1:** SATA Cable/Connector Connection Diagram

The connector on the left represents the Host with TX/RX differential pairs connected to a cable. The connector on the right shows the Device with TX/RX differential pairs also connected to the cable. Notice also the ground path connecting the shielding of the cable to the Cable Receptacle.

## 4. Product Specification

### 4.1 Capacity

Capacity specification of SDM4-M product family is available as shown in Table 4-1. It lists the specific capacity and the default numbers of heads, sectors and cylinders for each product line.

**Table 4-1:** Capacity specifications

Capacity	Total bytes	Cylinders	Heads	Sectors	Max LBA
4 GB	4,011,614,208	7,773	16	63	7,835,184
8 GB	8,012,390,400	15,525	16	63	15,649,200
16 GB	16,013,942,784	16,383	16	63	31,277,232
32 GB	32,017,047,552	16,383	16	63	62,533,296
64 GB	64,023,257,088	16,383	16	63	125,045,424

Notes:

Display of total bytes varies from file systems, which means not all of the bytes can be used for storage.

Cylinders, heads or sectors are not applicable for these capacities. Only LBA addressing applies.

LBA count addressed in the table above indicates total user storage capacity and will remain the same throughout the lifespan of the device. However, the total usable capacity of the SSD is most likely to be less than the total physical capacity because a small portion of the capacity is reserved for device maintenance usages.

### 4.2 Performance

Performances of SDM4-M are listed below in table 4-2.

**Table 4-2:** Performance (Typical)

Capacity	4 GB	8 GB	16 GB	32 GB	64 GB
<b>Performance</b>					
<b>Sustained read (MB/s)</b>	65	65	70	80	80
<b>Sustained write (MB/s)</b>	12	12	17	43	43

Note: Results may differ from various flash configurations or host system settings.

---

## 4.3 Environmental Specifications

---

Environmental specification of SDM4-M product family follows military standards, indicated in Table 4-3.

Table 4-3 SDM4-M environmental specifications

Item	Specification
Operating temperature	0~70(°C)
Extended temperature	-40 ~ +85(°C)
Storage temperature	-40~100(°C)
Vibration (non-operating)	10~2000(Hz), 15(G), sine wave, X, Y, Z axis
Vibration (operating)	20~2000(Hz), 7.69 (Grms), random wave, X, Y, Z axis
Shock (non-operating)	1500(G) half-sine wave, ±X, ±Y, ±Z axis
Shock (operating)	50(G), half sine wave, ±X, ±Y, ±Z axis

Note: extended operating temperature specifications are only available for 8, 16, 32GB capacities.

---

## 4.4 Mean Time Between Failures (MTBF)

---

Mean Time Between Failures (MTBF) is predicted based on reliability data for the individual components in SDM4-M. The prediction result for SDM4-M is more than 2,000,000 hours.

Notes about the MTBF:

The MTBF is predicated and calculated based on “Telcordia Technologies Special Report, SR-332, Issue 2” method.

---

## 4.5 Certification and Compliance

---

SDM4-M complies with the following standards:

- CE
- FCC
- RoHS
- MIL-STD-810

---

## **5. Flash Management**

### **5.1 Error Correction/Detection**

---

SDM4-M implements a hardware ECC scheme, based on the BCH algorithm. It can detect and correct up to 16 bits or 24 bits error in 1K bytes.

### **5.2 Flash Block Management**

---

Current production technology is unable to guarantee total reliability of NAND flash memory array. When a flash memory device leaves factory, it comes with a minimal number of initial bad blocks during production or out-of-factory as there is no currently known technology that produce flash chips free of bad blocks. In addition, bad blocks may develop during program/erase cycles. When host performs program/erase command on a block, bad block may appear in Status Register. Since bad blocks are inevitable, the solution is to keep them in control. Apacer flash devices are programmed with ECC, block mapping technique and S.M.A.R.T to reduce invalidity or error. Once bad blocks are detected, data in those blocks will be transferred to free blocks and error will be corrected by designated algorithms.

### **5.3 Wear Leveling**

---

Flash memory devices differ from Hard Disk Drives (HDDs) in terms of how blocks are utilized. For HDDs, when a change is made to stored data, like erase or update, the controller mechanism on HDDs will perform overwrites on blocks. Unlike HDDs, flash blocks cannot be overwritten and each P/E cycle wears down the lifespan of blocks gradually. Repeatedly program/erase cycles performed on the same memory cells will eventually cause some blocks to age faster than others. This would bring flash storages to their end of service term sooner. Wear leveling is an important mechanism that level out the wearing of blocks so that the wearing-down of blocks can be almost evenly distributed. This will increase the lifespan of SSDs. Commonly used wear leveling types are Static and Dynamic.

### **5.4 Power Failure Management**

---

Power Failure Management plays a crucial role when experiencing unstable power supply. Power disruption may occur when users are storing data into the SSD. In this urgent situation, the controller would run multiple write-to-flash cycles to store the metadata for later block rebuilding. This urgent operation requires about several milliseconds to get it done. At the next power up, the firmware will perform a status tracking to retrieve the mapping table and resume previously programmed NAND blocks to check if there is any incompleteness of transmission.

### **5.5 ATA Secure Erase**

---

AATA Secure Erase is an ATA disk purging command currently embedded in most of the storage drives. Defined in ATA specifications, (ATA) Secure Erase is part of Security Feature Set that allows storage drives to erase all user data areas. The erase process usually runs on the firmware level as most of the ATA-based storage media currently in the market are built-in with this command. ATA Secure Erase can securely wipe out the user data in the drive and protects it from malicious attack.

---

## **5.6 S.M.A.R.T.**

---

S.M.A.R.T. is an abbreviation for Self-Monitoring, Analysis and Reporting Technology, a self-monitoring system that provides indicators of drive health as well as potential disk problems. It serves as a warning for users from unscheduled downtime by monitoring and displaying critical drive information. Ideally, this should allow taking proactive actions to prevent drive failure and make use of S.M.A.R.T. information for future product development reference.

Apacer devices use the standard SMART command B0h to read data out from the drive to activate our S.M.A.R.T. feature that complies with the ATA/ATAPI specifications. S.M.A.R.T. Attribute IDs shall include initial bad block count, total later bad block count, maximum erase count, average erase count, power on hours and power cycle. When the S.M.A.R.T. Utility running on the host, it analyzes and reports the disk status to the host before the device reaches in critical condition.

Note: attribute IDs may vary from product models due to various solution design and supporting capabilities.

## **5.7 TRIM**

---

TRIM is a SATA command that helps improve the read/write performance and efficiency of solid-state drives (SSD). The command enables the host operating system to inform SSD controller which blocks contain invalid data, mostly because of the erase commands from host. The invalid will be discarded permanently and the SSD will retain more space for itself.

## 6. Software Interface

### 6.1 Command Set

This section defines the software requirements and the format of the commands the host sends to SDM4. Commands are issued to SDM4 by loading the required registers in the command block with the supplied parameters, and then writing the command code to the Command register.

**Table 6-1:** Command set

Code	Command	Code	Command
E5h	Check Power Mode	F3h	Security Erase Prepare
06h	Data Set Management	F4h	Security Erase Unit
90h	Execute Device Diagnostic	F5h	Security Freeze Lock
E7h	Flush Cache	F1h	Security Set Password
EAh	Flush Cache EXT	F2h	Security Unlock
Ech	Identify Device	70h	Seek
E3h	Idle	Efh	Set Features
E1h	Idle Immediate	C6h	Set Multiple Mode
91h	Initialize Device Parameters	E6h	Sleep
C8h	Read DMA	B0h	SMART
25h	Read DMA EXT	E2h	Standby
C4h	Read Multiple	E0h	Standby Immediate
29h	Read Multiple EXT	Cah	Write DMA
20h	Read Sector	35h	Write DMA EXT
24h	Read Sector EXT	C5h	Write Multiple
40h	Read Verify Sectors	39h	Write Multiple EXT
42h	Read Verify Sectors EXT	30h	Write Sector
10h	Recalibrate	34h	Write Sector EXT
F6h	Security Disable Password		

## 7. Electrical Specification

Table 7-1: Operating range

Item	Description
Required voltage	5V±5% (4.75-5.25V)
Operating temperature	0°C to +70°C (standard) -40°C to 85°C (extended)

Note: extended operating temperature specifications are only available for 8, 16, 32GB capacities.

Table 7-2: Typical power consumption

Capacity	4 GB	8 GB	16 GB	32 GB	64 GB
Modes					
Active (mA)	178	178	178	210	225
Idle (mA)	83	88	88	88	88

Note: Results may differ from various flash configurations or host system settings.

## 8. Physical Characteristics

### 8.1 Power Cable Type

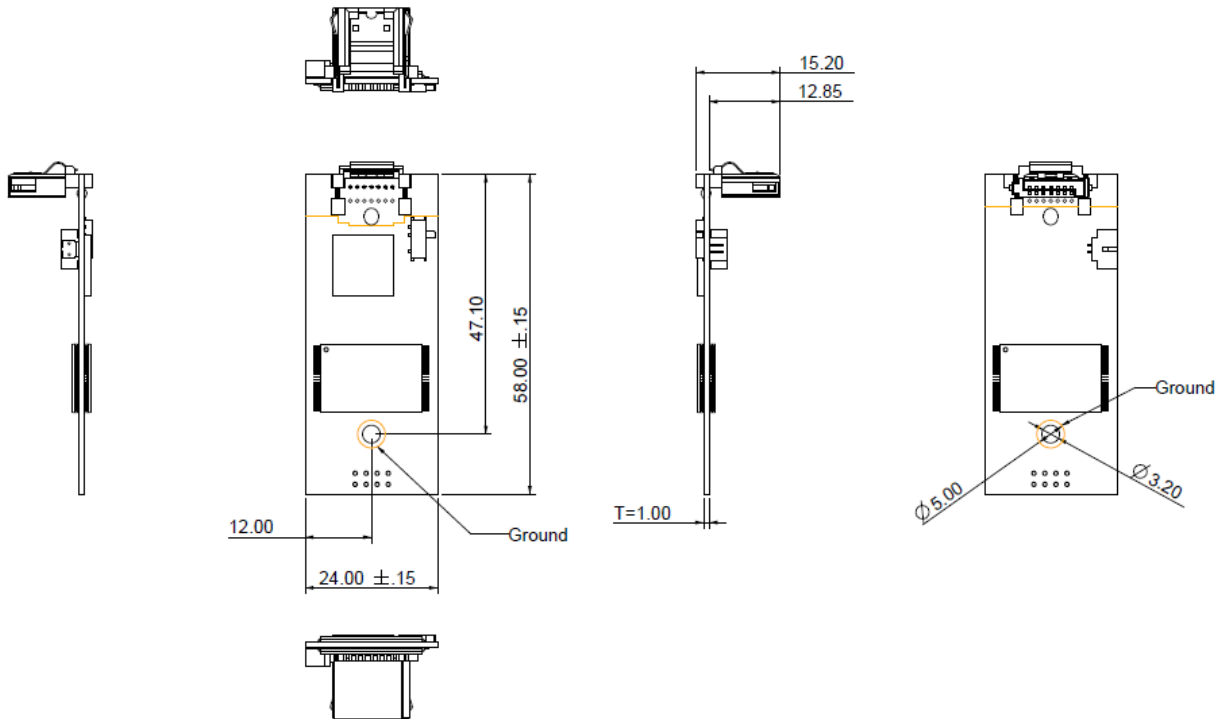

Unit: mm  
Tolerance: ± 0.25

# SATA-Disk Module 4 APSDMxxxxG5AN-PXXX

## 8.2 Power Cable-less Type

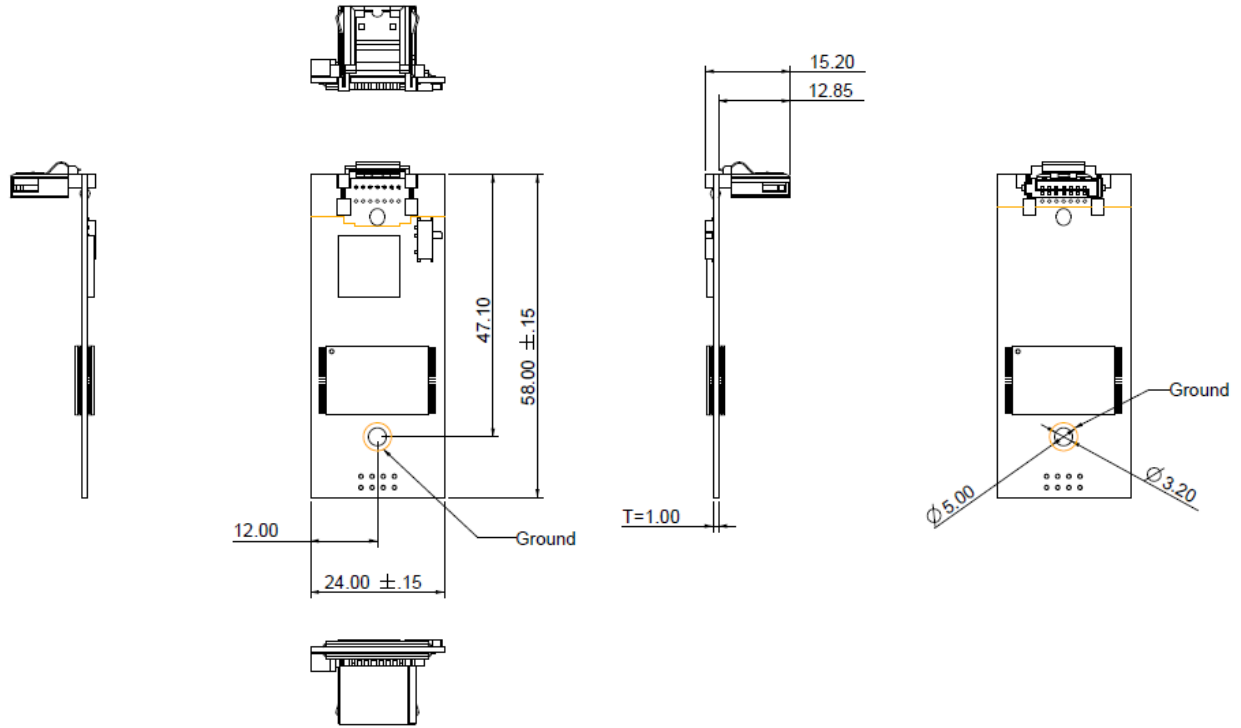

Unit: mm  
Tolerance: ± 0.25

### 8.3 Write Protect Switch (optional)

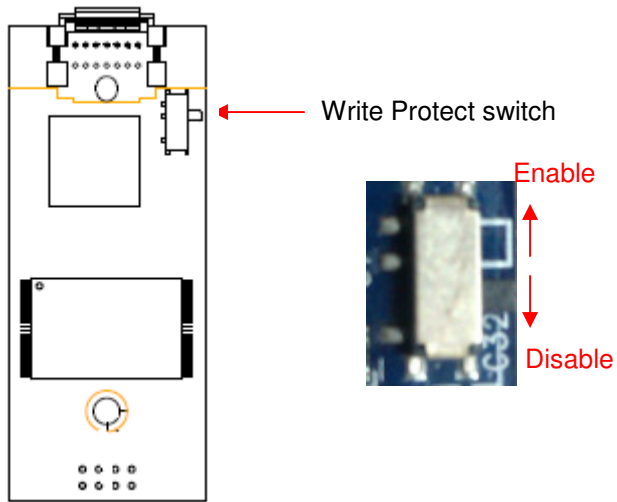

Description of Apacer Write Protect:

Apacer implements the Virtual Write scheme that allows write commands to go through the flash controller and data is temporarily stored, but no data has been actually written into the flash. Once the host resets or restarts the system, all the temporarily stored data will disappear and nowhere to be found in the drive. Since the Virtual Write scheme runs at device level, it requires no software or driver installation and is independent from the host OS.

## 9. Product Ordering Information

### 9.1 Product Code Designations

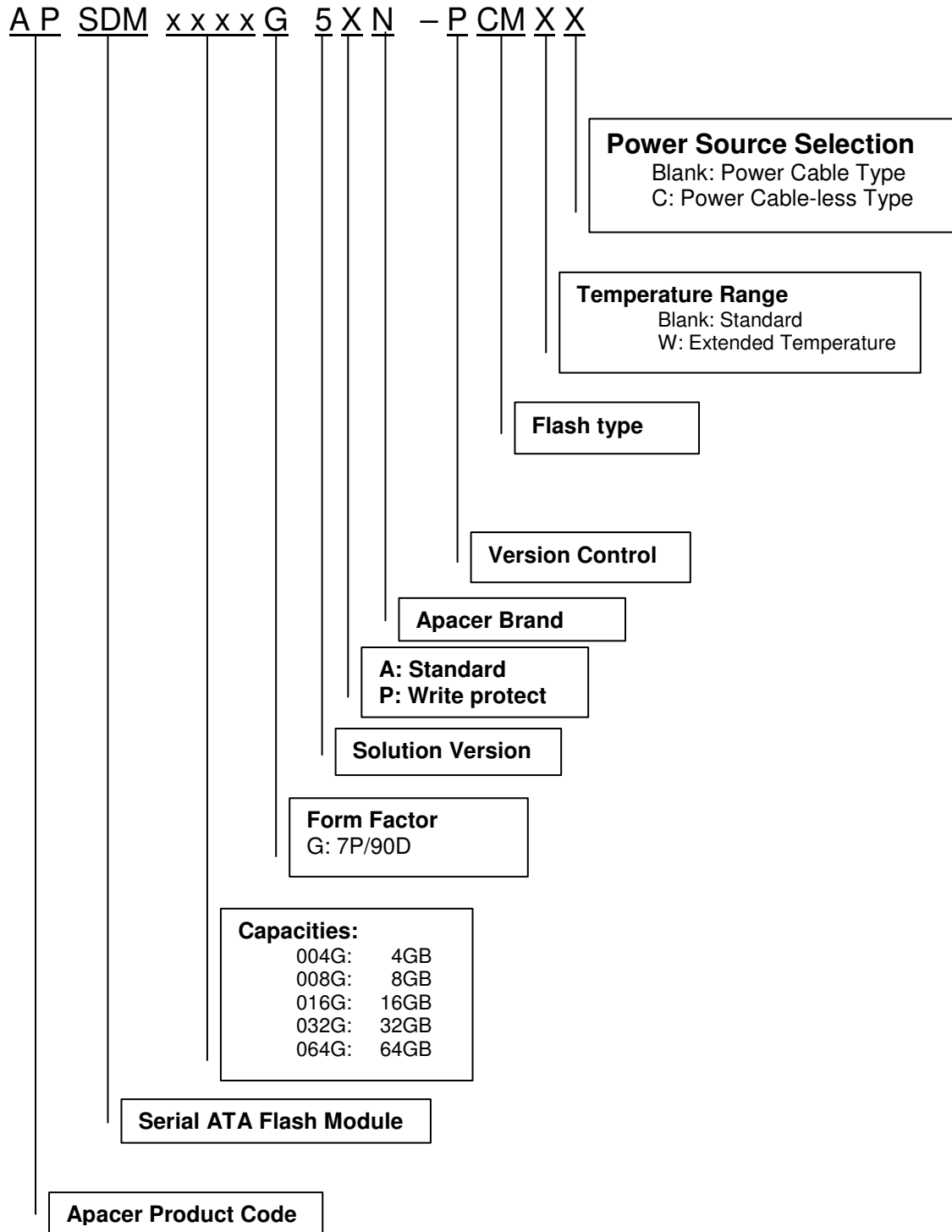

## 9.2 Valid Combinations

### 7P/90D MP: Power Cable Type

Capacity	Standard	Extended Temperature
4GB	APSDM004GG5AN-PCM	--
8GB	APSDM008GG5AN-PCM	APSDM008GG5AN-PCMW
16GB	APSDM016GG5AN-PCM	APSDM016GG5AN-PCMW
32GB	APSDM032GG5AN-PCM	APSDM032GG5AN-PCMW
64GB	APSDM064GG5AN-PCM	--

### 7P/90D MP: Power Cable-less Type

Capacity	Standard	Extended Temperature
4GB	APSDM004GG5AN-PCMC	--
8GB	APSDM008GG5AN-PCMC	APSDM008GG5AN-PCMWC
16GB	APSDM016GG5AN-PCMC	APSDM016GG5AN-PCMWC
32GB	APSDM032GG5AN-PCMC	APSDM032GG5AN-PCMWC
64GB	APSDM064GG5AN-PCMC	--

### 7P/90D MP: Power Cable Type with write protect

Capacity	Standard	Extended Temperature
4GB	APSDM004GG5PN-PCM	--
8GB	APSDM008GG5PN-PCM	APSDM008GG5PN-PCMW
16GB	APSDM016GG5PN-PCM	APSDM016GG5PN-PCMW
32GB	APSDM032GG5PN-PCM	APSDM032GG5PN-PCMW
64GB	APSDM064GG5PN-PCM	--

### 7P/90D MP: Power Cable-less Type with write protect

Capacity	Standard	Extended Temperature
4GB	APSDM004GG5PN-PCMC	--
8GB	APSDM008GG5PN-PCMC	APSDM008GG5PN-PCMWC
16GB	APSDM016GG5PN-PCMC	APSDM016GG5PN-PCMWC
32GB	APSDM032GG5PN-PCMC	APSDM032GG5PN-PCMWC
64GB	APSDM064GG5PN-PCMC	--

Note: Please consult with Apacer sales representative for availabilities.

---

## Revision History

Revision	Date	Description	Remark
1.0	12/02/2011	Official release	
1.1	1/17/2012	Revised capacity information Updated Product Ordering Information Added Power cable-less model	
1.2	11/09/2012	Updated Product Ordering Information due to firmware upgrade Added Write Protect option	
1.3	07/05/2013	Updated Product Ordering Information due to firmware upgrade	
1.4	11/04/2013	Simplified the TRIM section Updated the address of Taiwan headquarter	

---

## Global Presence

<b>Taiwan (Headquarters)</b>	<b>Apacer Technology Inc.</b> 1F., No.32, Zhongcheng Rd., Tucheng Dist., New Taipei City 236, Taiwan R.O.C. Tel: 886-2-2267-8000 Fax: 886-2-2267-2261 <a href="mailto:amtsales@apacer.com">amtsales@apacer.com</a>
<b>U.S.A.</b>	<b>Apacer Memory America, Inc.</b> 386 Fairview Way, Suite102, Milpitas, CA 95035 Tel: 1-408-518-8699 Fax: 1-408-935-9611 <a href="mailto:sa@apacerus.com">sa@apacerus.com</a>
<b>Japan</b>	<b>Apacer Technology Corp.</b> 5F, Matsura Bldg., Shiba, Minato-Ku Tokyo, 105-0014, Japan Tel: 81-3-5419-2668 Fax: 81-3-5419-0018 <a href="mailto:jpservices@apacer.com">jpservices@apacer.com</a>
<b>Europe</b>	<b>Apacer Technology B.V.</b> Science Park Eindhoven 5051 5692 EB Son, The Netherlands Tel: 31-40-267-0000 Fax: 31-40-267-0000#6199 <a href="mailto:sales@apacer.nl">sales@apacer.nl</a>
<b>China</b>	<b>Apacer Electronic (Shanghai) Co., Ltd</b> 1301, No.251, Xiaomujiao Road, Shanghai, 200032, China Tel: 86-21-5529-0222 Fax: 86-21-5206-6939 <a href="mailto:sales@apacer.com.cn">sales@apacer.com.cn</a>
<b>India</b>	<b>Apacer Technologies Pvt Ltd,</b> # 535, 1st Floor, 8th cross, JP Nagar 3rd Phase, Bangalore – 560078, India Tel: 91-80-4152-9061 <a href="mailto:sales_india@apacer.com">sales_india@apacer.com</a>