

RoHS Recast Compliant

SATA-Disk Module 4

SDM4 7P/180D Left-1U Type Specifications

May 10th, 2013

Version 1.3



Apacer Technology Inc.

4th Fl., 75 Hsin Tai Wu Rd., Sec.1, Xizhi, New Taipei City, Taiwan 221

Tel: +886-2-2698-2888 Fax: +886-2-2698-2889

www.apacer.com

Features:

- **Standard Serial ATA 2.6 (Gen. 2)**
 - Serial ATA 2.6 (Gen. 2)
 - SATA II, 3.0 Gbps
 - ATA-compatible command set
 - ATA modes support
- **Capacities**
 - 2, 4, 8, 16, 32 GB
- **Performance***
 - Burst read/write: 300 MB/sec
 - Sustained read: up to 85 MB/sec
 - Sustained write: up to 80 MB/sec
- **Intelligent endurance design**
 - Built-in hardware ECC, enabling up to 16/24 bit correction per 1K bytes
 - Static wear-leveling scheme together with dynamical block allocation to significantly increase the lifetime of a flash device and optimize the disk performance
 - Flash bad-block management
 - S.M.A.R.T.
 - Power Failure Management
 - ATA Secure Erase
 - TRIM
- **NAND Flash Type: SLC**
- **MTBF: >2,000,000 hours**
- **Endurance (TBW: Terabytes Written)**
 - 2GB: 96 TBW
 - 4GB: 192 TBW
 - 8GB: 384 TBW
 - 16GB: 769 TBW
 - 32GB: 1539 TBW
- **Temperature ranges**
 - Operation:
 - Standard: 0°C to 70°C
 - Extended: -40 ~ +85°C
 - Storage: -40°C to 100°C
- **Supply voltage**
 - 5.0 V \pm 5%
- **Power consumption (typical)***
 - Active mode: 233 mA@5.0 V
 - Idle mode: 75 mA@5.0 V
- **Connector type**
 - 7-pin signal connector
- **Form factor**
 - SATA Disk Module
 - Dimension (w/o housing):
42.00x30.35x1.00**, unit: mm
 - Dimension (w/ housing):45.90x32.35x7.70,
unit: mm
- **Shock & Vibration**
 - Shock: 500 G (non-operating)
 - Vibration: 15 G (non-operating)
- **Write Protect (optional)**
 - Triggered by onboard hardware switch
- **RoHS Recast compliant (2011/65/EU)**

*Varies from capacities. The values for performances and power consumptions presented are typical and may vary depending on flash configurations or platform settings. The term idle refers to the standby state of the device.

**The thickness of the module, without including the size of attached chips and connectors.

Table of Contents

| | |
|--|-----------|
| 1. GENERAL DESCRIPTION | 3 |
| 1.1 PERFORMANCE-OPTIMIZED CONTROLLER | 3 |
| 1.1.1 Power Management..... | 3 |
| 1.1.2 RAM..... | 3 |
| 2. FUNCTIONAL BLOCK | 4 |
| 3. PIN ASSIGNMENTS | 5 |
| 4. PRODUCT SPECIFICATIONS | 7 |
| 4.1 CAPACITY..... | 7 |
| 4.2 ATA MODES SUPPORT | 7 |
| 4.3 PERFORMANCE..... | 7 |
| 4.4 ENDURANCE | 8 |
| 4.5 ENVIRONMENTAL SPECIFICATIONS..... | 8 |
| 4.6 MEAN TIME BETWEEN FAILURES (MTBF)..... | 8 |
| 4.7 CERTIFICATION AND COMPLIANCE | 9 |
| 5. FLASH MANAGEMENT | 10 |
| 5.1 ERROR CORRECTION/DETECTION | 10 |
| 5.2 BAD BLOCK MANAGEMENT | 10 |
| 5.3 WEAR LEVELING | 10 |
| 5.4 POWER FAILURE MANAGEMENT..... | 10 |
| 5.5 ATA SECURE ERASE | 10 |
| 5.6 S.M.A.R.T..... | 11 |
| 5.7 TRIM | 11 |
| 6. SOFTWARE INTERFACE | 12 |
| 6.1 COMMAND SET | 12 |
| 7. ELECTRICAL SPECIFICATION | 13 |
| 8. PHYSICAL CHARACTERISTICS | 14 |
| 8.1 W/ HOUSING..... | 14 |
| 8.2 W/O HOUSING | 15 |
| 8.3 WRITE PROTECT SWITCH (OPTIONAL)..... | 16 |
| 9. PRODUCT ORDERING INFORMATION | 17 |
| 9.1 PRODUCT CODE DESIGNATIONS | 17 |
| 9.2 VALID COMBINATIONS..... | 18 |

1. General Description

Apacer's SATA-Disk Module 4-M (SDM4-M) is a high-performance, embedded SSD designed to replace the conventional SATA hard disk drive. SDM SSD can be plugged into a standard Serial ATA connectors commonly found in desktops, IT-STB, industrial PC and thin client systems.

Apacer's SDM4-M is built in with an efficient microcontroller that drives the potential of NAND flashy and delivers optimal performance. With its compact form factor and SATA II interface, this product is well suited for embedded flash storage applications offering customizable and expanded functionalities as well as more cost-effective designs, better performance and increased reliability.

SDM4-M Series is designed to work at 5 Volts and uses a standard SATA driver that complies with major operating systems such as Microsoft's Windows series. Featuring technologies as Apacer-specific Wear-leveling algorithms, S.M.A.R.T, bad block management, Power Failure Management, ATA Secure Erase, and TRIM, Apacer assures users of a versatile device on data storage.

1.1 Performance-Optimized Controller

The heart of SDM4 is the Flash controller, which translates standard SATA signals into the data and controls of the flash media. The SATA and Flash Management controller are specifically designed to attain high data throughput from the host to the flash.

1.1.1 Power Management

The controller comes with SATA physical interface (PHY) that takes a significant part of the total power budget of the host or other connected electronics. SATA interface provides the means to place the PHY into lowered power modes. When the parts of power for PHY are shut down to reserve power supply, the ability of the SATA interfaced device to respond to command can be affected. Thus, the SATA protocol is implemented with the capability to track the power modes of the devices and require the additional latency to wake up PHY from lowered power modes.

1.1.2 RAM

The controller is implemented with RAM as a data buffer to optimize data transfer between the host and the flash media.

2. Functional Block

SDM4 includes the SATA and Flash Management controllers, and flash media, as well as the SATA standard interface. Figure 2-1 shows the functional block diagram.

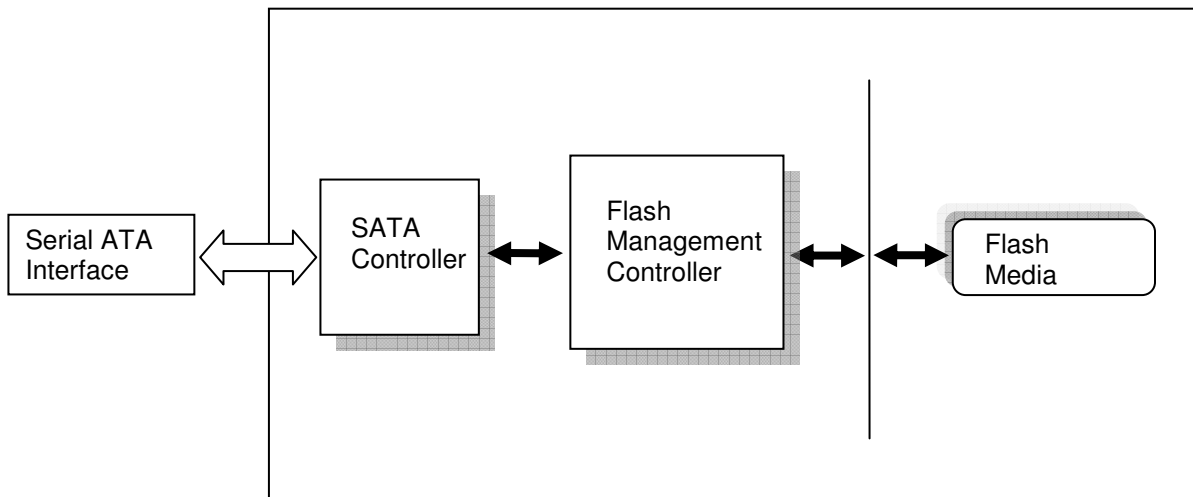
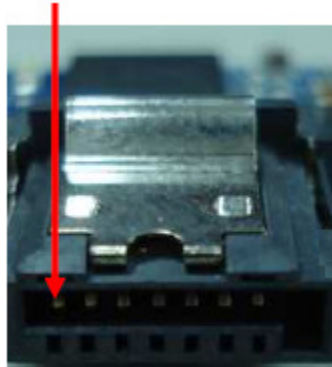

Figure 2-1: Functional block diagram

3. Pin Assignments

Signal P1



Power cable type w/o Housing

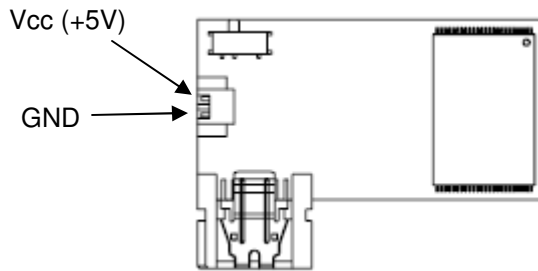

Power cable type w/ Housing

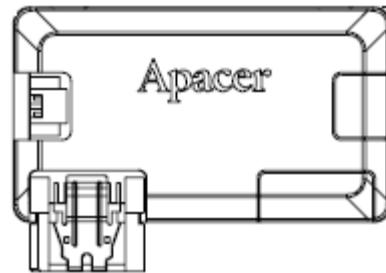

Signal Segment

| Pin | Type | Signal Description |
|-----|------|-------------------------------|
| S1 | GND | |
| S2 | RxP | +Differential Receive Signal |
| S3 | RxN | -Differential Receive Signal |
| S4 | GND | |
| S5 | TxN | -Differential Transmit Signal |
| S6 | TxP | +Differential Transmit Signal |
| S7 | GND | |

Power Segment

| Pin | Signal Description |
|-----|--------------------|
| P1 | Vcc (+5V) |
| P2 | GND |

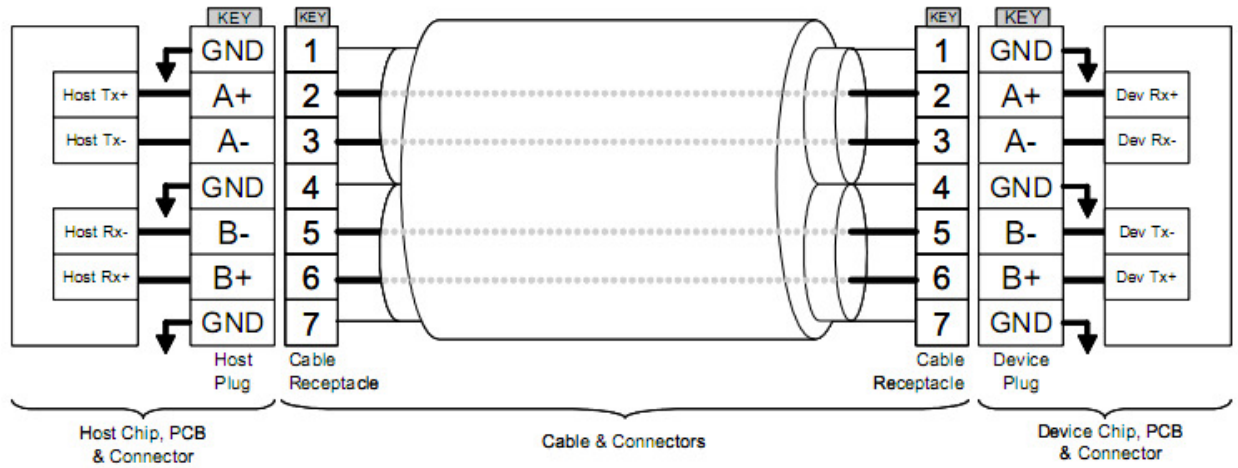

Figure 3-1: SATA Cable/Connector Connection Diagram

The connector on the left represents the Host with TX/RX differential pairs connected to a cable. The connector on the right shows the Device with TX/RX differential pairs also connected to the cable. Notice also the ground path connecting the shielding of the cable to the Cable Receptacle.

4. Product Specifications

4.1 Capacity

Capacity specification of SDM4 product family is available as shown in Table 4-1. It lists the specific capacity and the default numbers of heads, sectors and cylinders for each product line.

Table 4-1: Capacity specifications

| Capacity | Total bytes* | Cylinders | Heads | Sectors | Max LBA |
|----------|----------------|-----------|-------|---------|------------|
| 2 GB | 2,011,226,112 | 3,897 | 16 | 63 | 3,928,176 |
| 4 GB | 4,011,614,208 | 7,773 | 16 | 63 | 7,835,184 |
| 8 GB | 8,012,390,400 | 15,525 | 16 | 63 | 15,649,200 |
| 16 GB | 16,013,942,784 | 16,383 | 16 | 63 | 31,277,232 |
| 32 GB | 32,017,047,552 | 16,383 | 16 | 63 | 62,533,296 |

*Display of total bytes varies from file systems which means not all of the bytes can be used for storage.

**Notes: 1 GB = 1,000,000,000 bytes; 1 sector = 512 bytes.

LBA count addressed in the table above indicates total user storage capacity and will remain the same throughout the lifespan of the device. However, the total usable capacity of the device is most likely to be less than the total physical capacity because a small portion of the capacity is reserved for device maintenance usages.

4.2 ATA Modes support

SDM4 supports the following ATA operating modes:

- Supports up to PIO Mode-4
- Supports up to Multi-word DMA Mode-2
- Supports up to Ultra DMA Mode-5

4.3 Performance

Performances of SDM4 are listed below in table 4-2.

Table 4-2: Performance (Typical)

| Capacity | 2 GB | 4 GB | 8 GB | 16 GB | 32 GB |
|-------------------------------|------|------|------|-------|-------|
| Performance | | | | | |
| Sustained read (MB/s) | 75 | 80 | 80 | 85 | 85 |
| Sustained write (MB/s) | 28 | 50 | 55 | 80 | 80 |

Note: Results may differ from various flash configurations or host system settings.

4.4 Endurance

Terabytes Written (TBW) is an endurance rating system that indicates the maximum number of terabytes written by the host to the drive. NAND flash has a limit on how many P/E cycles it can withstand before its data retention becomes unreliable. Thus, key factors, such as wear leveling, flash configurations, Write Amplifications and the number of P/E cycles, can influence the endurance of the drive.

The TBW of the device are listed in the following table.

| Capacity | TBW (TB) |
|----------|----------|
| 2 GB | 96 |
| 4 GB | 192 |
| 8 GB | 384 |
| 16 GB | 769 |
| 32 GB | 1539 |

Notes:

- The measurement assumes the data written to the SSD for test is under a typical and constant rate.
- The measurement follows the standard metric: 1 TB (Terabyte) = 1000 GB.

4.5 Environmental Specifications

Environmental specification of SDM4 series follows the military standards, shown in the table below.

Table 4-3 SDM4 environmental specifications

| Item | Specification |
|---------------------------|---|
| Operating temperature | 0~70(°C) |
| Extended temperature | -40 ~ +85(°C) |
| Storage temperature | -40~100(°C) |
| Vibration (non-operating) | 10~2000(Hz), 15(G), sine wave, X, Y, Z axis |
| Shock (non-operating) | 500(G) half-sine wave, ±X, ±Y, ±Z axis |

4.6 Mean Time Between Failures (MTBF)

Mean Time Between Failures (MTBF) is predicted based on reliability data for the individual components in SDM4. The prediction result for SDM4 is more than 2,000,000 hours.

Notes about MTBF:

The prediction is based on Bellcore analysis method by assuming device failure rate can be generated by the sum of failure rates in each component.

4.7 Certification and Compliance

SDM4 complies with the following standards:

- CE
- FCC
- RoHS Recast
- MIL-STD-202 and MIL-STD-810

5. Flash Management

5.1 Error Correction/Detection

SDM4 implements a hardware ECC which is based on the BCH algorithm. It can detect and correct up to 16 bits or 24 bits error in 1K bytes depending on the NAND flash configuration used.

5.2 Bad Block Management

Current production technology is unable to guarantee total reliability of NAND flash memory array. When a flash memory device leaves factory, it comes with a minimal number of initial bad blocks during production or out-of-factory as there is no currently known technology that produce flash chips free of bad blocks. In addition, bad blocks may develop during program/erase cycles. When host performs program/erase command on a block, bad block may appear in Status Register. Since bad blocks are inevitable, the solution is to keep them in control. Apacer flash devices are programmed with ECC, block mapping technique and S.M.A.R.T to reduce invalidity or error. Once bad blocks are detected, data in those blocks will be transferred to free blocks and error will be corrected by designated algorithms.

5.3 Wear Leveling

Flash memory devices differ from Hard Disk Drives (HDDs) in terms of how blocks are utilized. For HDDs, when a change is made to stored data, like erase or update, the controller mechanism on HDDs will perform overwrites on blocks. Unlike HDDs, flash blocks cannot be overwritten and each P/E cycle wears down the lifespan of blocks gradually. Repeatedly program/erase cycles performed on the same memory cells will eventually cause some blocks to age faster than others. This would bring flash storages to their end of service term sooner. Wear leveling is an important mechanism that level out the wearing of blocks so that the wearing-down of blocks can be almost evenly distributed. This will increase the lifespan of SSDs. Commonly used wear leveling types are Static and Dynamic.

5.4 Power Failure Management

Power Failure Management plays a crucial role when experiencing unstable power supply. Power disruption may occur when users are storing data into the SSD. In this urgent situation, the controller would run multiple write-to-flash cycles to store the metadata for later block rebuilding. This urgent operation requires about several milliseconds to get it done. At the next power up, the firmware will perform a status tracking to retrieve the mapping table and resume previously programmed NAND blocks to check if there is any incompleteness of transmission.

5.5 ATA Secure Erase

ATA Secure Erase is an ATA disk purging command currently embedded in most of the storage drives. Defined in ATA specifications, (ATA) Secure Erase is part of Security Feature Set that allows storage drives to erase all user data areas. The erase process usually runs on the firmware level as most of the ATA-based storage media currently in the market are built-in with this command. ATA Secure Erase can securely wipe out the user data in the drive and protects it from malicious attack.

5.6 S.M.A.R.T.

S.M.A.R.T. is an abbreviation for Self-Monitoring, Analysis and Reporting Technology, a self-monitoring system that provides indicators of drive health as well as potential disk problems. It serves as a warning for users from unscheduled downtime by monitoring and displaying critical drive information. Ideally, this should allow taking proactive actions to prevent drive failure and make use of S.M.A.R.T. information for future product development reference.

Apacer devices use the standard SMART command B0h to read data out from the drive to activate our S.M.A.R.T. feature that complies with the ATA/ATAPI specifications. S.M.A.R.T. Attribute IDs shall include initial bad block count, total later bad block count, maximum erase count, average erase count, power on hours and power cycle. When the S.M.A.R.T. Utility running on the host, it analyzes and reports the disk status to the host before the device reaches in critical condition.

Note: attribute IDs may vary from product models due to various solution design and supporting capabilities.

5.7 TRIM

TRIM, though in capital letters usually, is a memory computation command rather than an abbreviation. It is mainly a SATA command that enables the operating system to inform the SSD (Solid State Drive) which blocks of previously stored data are no longer valid, due to erases by the host or operating system, such as file deletions or disk formatting. Once notified, SSD will begin the discard of the invalid LBAs and retain more space for itself, in fact, the discarded is no longer recoverable.

When an LBA is replaced by the operating system, as with overwrite of a file, the SSD is informed that the originally occupied LBA is determined as no longer in use or invalid. The SSD will not save those blocks in garbage collected sectors. Noticeably, a file deletion command by host or operating system never actually erases the actual content, rather, just the file is marked as deleted. This issue is even specifically noticeable for flash based memory devices, such as SSDs. In fact, an SSD will keep garbage collecting the invalid, previously occupied LBAs, if it is not informed that these LBAs can be erased. Thus, the SSD would experience a significant performance downfall.

6. Software Interface

6.1 Command Set

This section defines the software requirements and the format of the commands the host sends to SDM4. Commands are issued to SDM4 by loading the required registers in the command block with the supplied parameters, and then writing the command code to the Command register.

Table 6-1: Command set

| Code | Command | Code | Command |
|------|------------------------------|------|------------------------|
| E5h | Check Power Mode | F3h | Security Erase Prepare |
| 06h | Data Set Management | F4h | Security Erase Unit |
| 90h | Execute Device Diagnostic | F5h | Security Freeze Lock |
| E7h | Flush Cache | F1h | Security Set Password |
| EAh | Flush Cache EXT | F2h | Security Unlock |
| ECh | Identify Device | 70h | Seek |
| E3h | Idle | EFh | Set Features |
| E1h | Idle Immediate | C6h | Set Multiple Mode |
| 91h | Initialize Device Parameters | E6h | Sleep |
| C8h | Read DMA | B0h | SMART |
| 25h | Read DMA EXT | E2h | Standby |
| C4h | Read Multiple | E0h | Standby Immediate |
| 29h | Read Multiple EXT | CAh | Write DMA |
| 20h | Read Sector | 35h | Write DMA EXT |
| 24h | Read Sector EXT | C5h | Write Multiple |
| 40h | Read Verify Sectors | 39h | Write Multiple EXT |
| 42h | Read Verify Sectors EXT | 30h | Write Sector |
| 10h | Recalibrate | 34h | Write Sector EXT |
| F6h | Security Disable Password | | |

7. Electrical Specification

Caution: Absolute Maximum Stress Ratings – Applied conditions greater than those listed under “Absolute Maximum Stress Ratings” may cause permanent damage to the device. This is a stress rating only and functional operation of the device at these conditions or conditions greater than those defined in the operational sections of this data sheet is not implied. Exposure to absolute maximum stress rating conditions may affect device reliability.

Table 7-1: Absolute stress ratings

| Parameter | Conditions |
|----------------------|----------------|
| Standard | 0°C to +70°C |
| Extended Temperature | -40°C to +85°C |
| Power supply | 4.75-5.25V |

Table 7-2: Power consumption (typical)

| Capacity | 2 GB | 4 GB | 8 GB | 16 GB | 32 GB |
|-------------|------|------|------|-------|-------|
| Modes | | | | | |
| Active (mA) | 180 | 210 | 215 | 220 | 230 |
| Idle (mA) | 70 | 72 | 75 | 75 | 75 |

Note: Results may differ from various flash configurations or platforms.

8. Physical Characteristics

8.1 W/ Housing

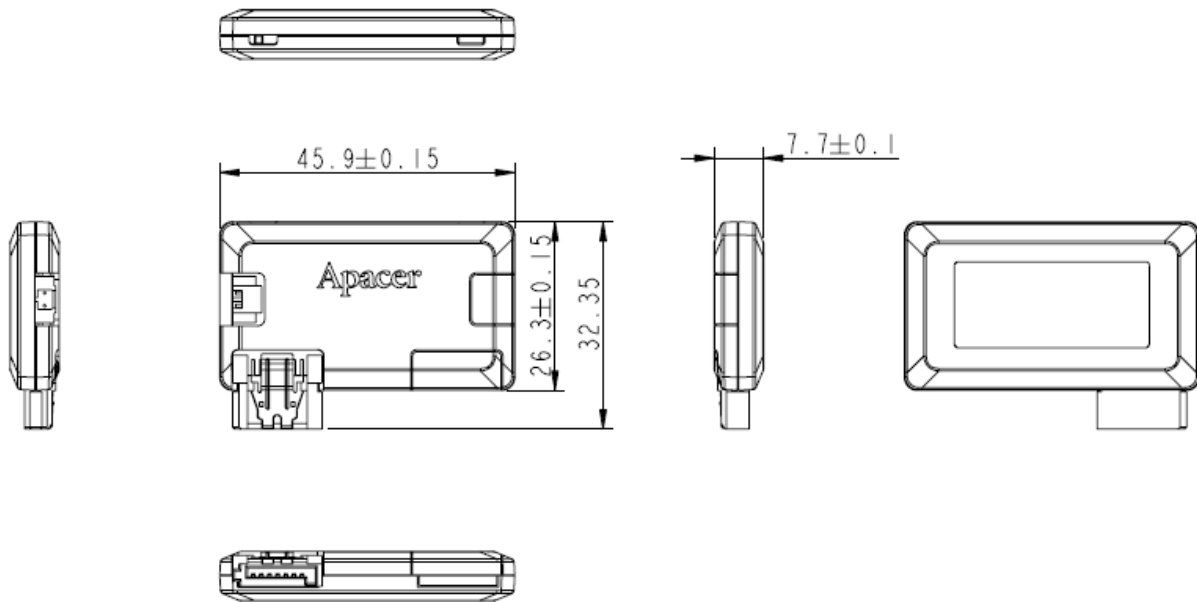

Unit: mm
Tolerance: ± 0.25

SATA-Disk Module 4
APSDMxxxxX5AN-PXX

8.2 W/o Housing

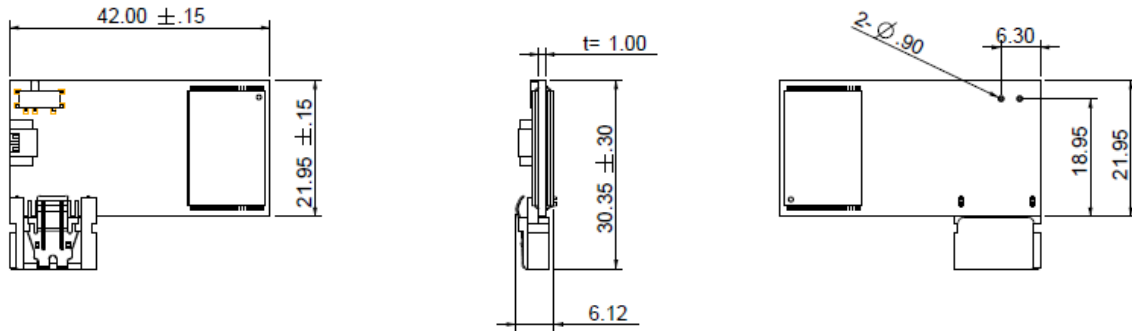

Unit: mm
Tolerance: ± 0.25

8.3 Write Protect Switch (optional)

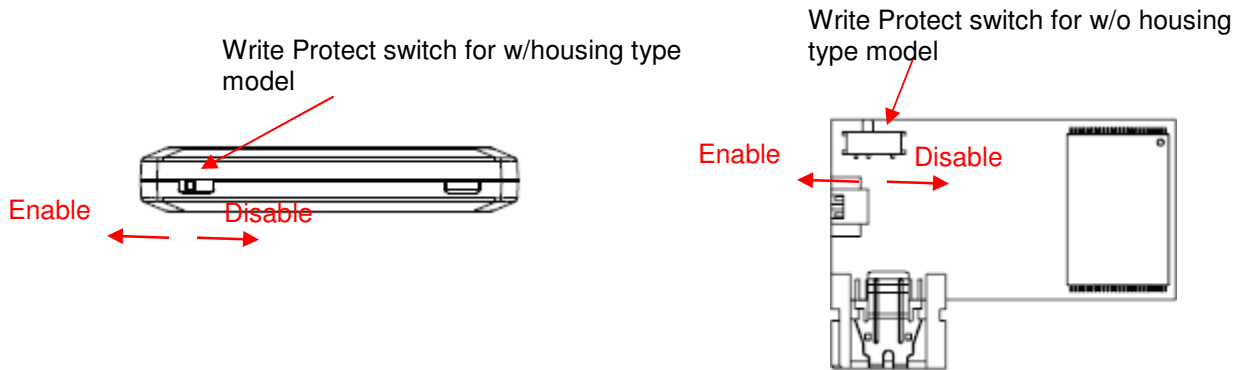

Description of Apacer Write Protect:

Apacer implements the Virtual Write scheme that allows write commands to go through the flash controller and data is temporarily stored, but no data has been actually written into the flash. Since the Virtual Write scheme runs at device level, it requires no software or driver installation and is independent from the host OS.

9. Product Ordering Information

9.1 Product Code Designations

A P SDM x x x x X 5 X N - P X X

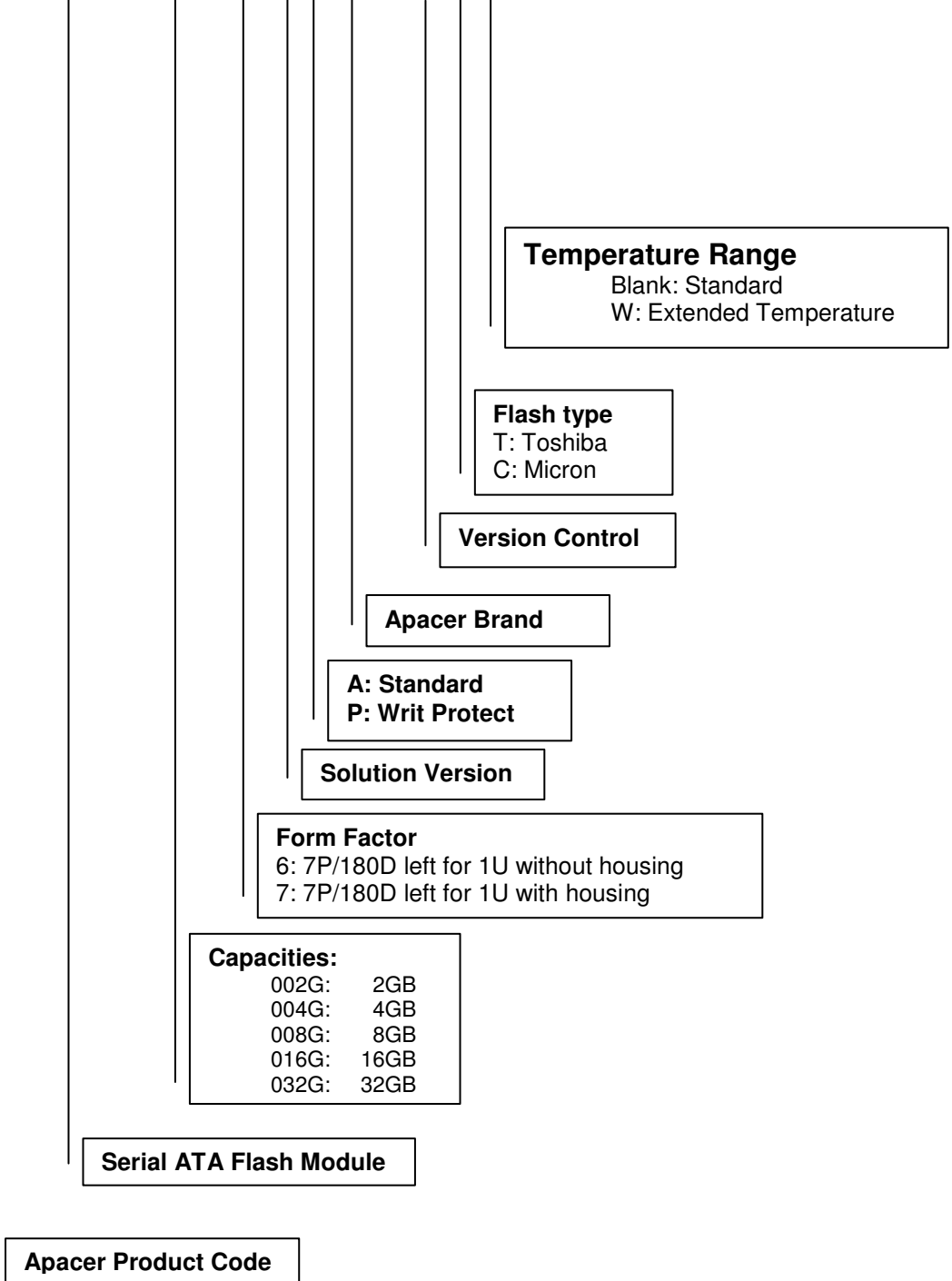

9.2 Valid Combinations

7P/180D RU (without housing): Standard

| Capacity | Standard | Extended Temperature |
|----------|------------------|----------------------|
| 2GB | APSDM002G65AN-PT | APSDM002G65AN-PTW |
| 4GB | APSDM004G65AN-PT | APSDM004G65AN-PTW |
| 8GB | APSDM008G65AN-PT | APSDM008G65AN-PTW |
| 16GB | APSDM016G65AN-PC | APSDM016G65AN-PCW |
| 32GB | APSDM032G65AN-PC | APSDM032G65AN-PCW |

7P/180D RUH (with housing): Standard

| Capacity | Standard | Extended Temperature |
|----------|------------------|----------------------|
| 2GB | APSDM002G75AN-PT | APSDM002G75AN-PTW |
| 4GB | APSDM004G75AN-PT | APSDM004G75AN-PTW |
| 8GB | APSDM008G75AN-PT | APSDM008G75AN-PTW |
| 16GB | APSDM016G75AN-PC | APSDM016G75AN-PCW |
| 32GB | APSDM032G75AN-PC | APSDM032G75AN-PCW |

7P/180D RU (without housing): Write protect

| Capacity | Standard | Extended Temperature |
|----------|------------------|----------------------|
| 2GB | APSDM002G65PN-PT | APSDM002G65PN-PTW |
| 4GB | APSDM004G65PN-PT | APSDM004G65PN-PTW |
| 8GB | APSDM008G65PN-PT | APSDM008G65PN-PTW |
| 16GB | APSDM016G65PN-PC | APSDM016G65PN-PCW |
| 32GB | APSDM032G65PN-PC | APSDM032G65PN-PCW |

7P/180D RUH (with housing): Write protect

| Capacity | Standard | Extended Temperature |
|----------|------------------|----------------------|
| 2GB | APSDM002G75PN-PT | APSDM002G75PN-PTW |
| 4GB | APSDM004G75PN-PT | APSDM004G75PN-PTW |
| 8GB | APSDM008G75PN-PT | APSDM008G75PN-PTW |
| 16GB | APSDM016G75PN-PC | APSDM016G75PN-PCW |
| 32GB | APSDM032G75PN-CC | APSDM032G75PN-CCW |

Note: please consult with Apacer sales representatives for availabilities.

Revision History

| Revision | Date | Description | Remark |
|----------|------------|--|--------|
| 1.0 | 08/03/2012 | Official release | |
| 1.1 | 09/14/2012 | Added Write Protect option | |
| 1.2 | 11/15/2012 | Revised Non-operating shock information: from 1500G to 500G | |
| 1.3 | 05/10/2013 | Updated Product Ordering Information due to firmware upgrade | |

Global Presence

| | |
|------------------------------|---|
| Taiwan (Headquarters) | Apacer Technology Inc. 4 th Fl., 75 Hsin Tai Wu Rd., Sec.1 Xizhi, New Taipei City Taiwan 221 R.O.C. Tel: +886-2-2698-2888 Fax: +886-2-2698-2889 amtsales@apacer.com |
| U.S.A. | Apacer Memory America, Inc. 386 Fairview Way, Suite102, Milpitas, CA 95035 Tel: 1-408-518-8699 Fax: 1-408-935-9611 sa@apacerus.com |
| Japan | Apacer Technology Corp. 5F, Matsura Bldg., Shiba, Minato-Ku Tokyo, 105-0014, Japan Tel: 81-3-5419-2668 Fax: 81-3-5419-0018 jpservices@apacer.com |
| Europe | Apacer Technology B.V. Science Park Eindhoven 5051 5692 EB Son, The Netherlands Tel: 31-40-267-0000 Fax: 31-40-267-0000#6199 sales@apacer.nl |
| China | Apacer Electronic (Shanghai) Co., Ltd 1301, No.251,Xiaomuqiao Road, Shanghai, 200032, China Tel: 86-21-5529-0222 Fax: 86-21-5206-6939 sales@apacer.com.cn |
| India | Apacer Technologies Pvt Ltd, # 535, 1st Floor, 8th cross, JP Nagar 3rd Phase, Bangalore – 560078, India Tel: 91-80-4152-9061 sales_india@apacer.com |