

*RoHS Compliant*

## **SATA-Disk Module 4**

***SDM4-M 7P/180D Low Profile 2 Specifications***

**October 25<sup>th</sup>, 2013**

*Version 1.2*



***Apacer Technology Inc.***

1F, No.32, Zhongcheng Rd., Tucheng Dist., New Taipei City, Taiwan, R.O.C

Tel: +886-2-2267-8000 Fax: +886-2-2267-2261

[www.apacer.com](http://www.apacer.com)

## Features:

- **Standard Serial ATA Revision 2.6**
  - Compliant with Serial ATA Revision 2.6
  - SATA 3.0 Gbps interface
  - ATA-compatible command set
- **Capacities**
  - 4, 8, 16, 32 GB
- **Performance\***
  - Burst read/write: 300 MB/sec
  - Sustained read: up to 43 MB/sec
  - Sustained write: up to 21 MB/sec
- **Intelligent endurance design**
  - Built-in hardware ECC, enabling up to 16/24 bit correction per 1K bytes
  - Static/dynamic wear-leveling
  - Flash bad-block management
  - S.M.A.R.T.
  - Power Failure Management
  - ATA Secure Erase
  - TRIM
- **NAND Flash Type: MLC**
- **MTBF: >1,000,000 hours**
- **Temperature ranges**
  - Operating:
    - Standard: 0°C to 70°C
    - Extended: -40 ~ +85°C \*\*\*
  - Storage: -40°C to 100°C
- **Supply voltage**
  - 5.0 V ± 5%
- **Power consumption (typical)\***
  - Active mode: 185 mA@5.0 V
  - Idle mode: 85 mA@5.0 V
- **Connector type**
  - 7-pin signal connector
  - 2-pin power connector
- **Form factor**
  - SATA Disk Module
  - Dimension\*\*: 33.00 x 29.30 x 9.15, unit: mm
- **Shock & Vibration\*\*\*\***
  - Shock: 1500 G
  - Vibration: 15 G
- **Write Protect by hardware switch (optional)**
  - Write Protect enabled by onboard switch
- **RoHS compliant**

\*Varies from capacities. The values for performances and power consumptions presented are typical and may vary depending on flash configurations or platform settings. The term idle refers to the standby state of the device.

\*\* The width (29.30 mm) includes the width of the SATA connector on the board, while the thickness (9.15 mm) indicates the maximum which includes the connectors on the board.

\*\*\*Only available in 4, 8, 16GB capacities. Please see "Product Ordering Information" for details.

\*\*\*\*Non-operating

---

## Table of Contents

<b>1. GENERAL DESCRIPTION</b> .....	<b>3</b>
<b>2. FUNCTIONAL BLOCK</b> .....	<b>3</b>
<b>3. PIN ASSIGNMENTS</b> .....	<b>4</b>
<b>4. PRODUCT SPECIFICATIONS</b> .....	<b>6</b>
4.1 CAPACITY .....	6
4.2 ATA MODES SUPPORT.....	6
4.3 PERFORMANCE .....	6
4.4 ENVIRONMENTAL SPECIFICATIONS.....	7
4.5 MEAN TIME BETWEEN FAILURES (MTBF).....	7
4.6 CERTIFICATION AND COMPLIANCE .....	7
<b>5. FLASH MANAGEMENT</b> .....	<b>8</b>
5.1 ERROR CORRECTION/DETECTION .....	8
5.2 BAD BLOCK MANAGEMENT .....	8
5.3 WEAR LEVELING .....	8
5.4 POWER FAILURE MANAGEMENT.....	8
5.5 ATA SECURE ERASE .....	8
5.6 S.M.A.R.T.....	9
5.7 TRIM .....	9
<b>6. SOFTWARE INTERFACE</b> .....	<b>10</b>
6.1 COMMAND SET .....	10
<b>7. ELECTRICAL SPECIFICATION</b> .....	<b>11</b>
<b>8. PHYSICAL CHARACTERISTICS</b> .....	<b>12</b>
8.1 DIMENSIONS .....	12
8.2 WRITE PROTECT SWITCH (OPTIONAL).....	13
<b>9. PRODUCT ORDERING INFORMATION</b> .....	<b>14</b>
9.1 PRODUCT CODE DESIGNATIONS .....	14

## 1. General Description

Apacer's SATA-Disk Module 4 (SDM4) is a high-performance, embedded SSD designed to replace the conventional SATA hard disk drive. SDM SSD can be plugged into a standard Serial ATA 7-pin connector commonly found in desktops, IT-STB, industrial PC and thin client systems. Moreover, SDM4 provides an innovative way for design-in clients with compact host systems. Though built with MLC, this SSD can work in highly demanding environment as it can withstand ambient temperature from -40°C to +85°C (for certain capacities only).

Apacer's SDM4 has a built-in microcontroller with file management firmware that communicates with SATA standard interface. Designed with compact size and flexibility, this product is well suited for embedded flash storage applications offering new and expanded functionalities as well as more cost-effective designs, better performance and increased reliability.

SDM4 Series is designed to work at 5 Volts and uses a standard SATA driver that complies with major operating systems such as Microsoft's Windows series. Featuring technologies as Apacer-specific Wear-leveling algorithms, S.M.A.R.T, Power Failure Management, ATA Secure Erase, and TRIM, Apacer assures users of a versatile device on data storage.

## 2. Functional Block

SDM4-M includes the SATA and Flash Management controllers, and flash media, as well as the SATA standard interface. Figure 2-1 shows the functional block diagram.

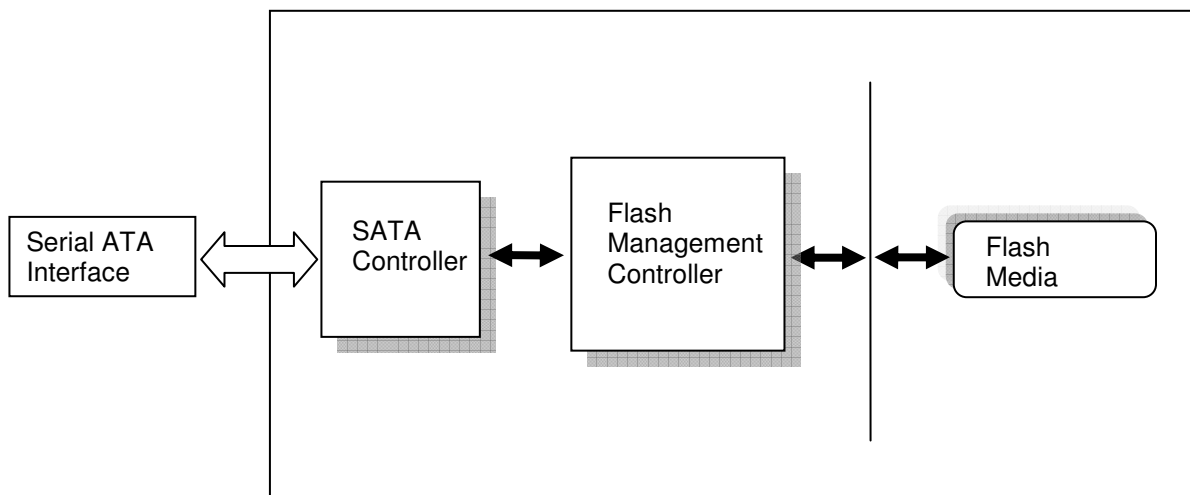

**Figure 2-1:** Functional block diagram

### 3. Pin Assignments

Signal Pin 1

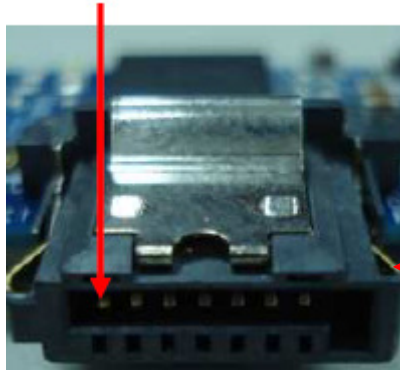

Power Pin1

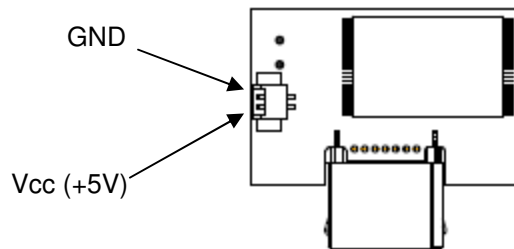

Signal Segment

Pin	Type	Signal Description
S1	GND	
S2	RxP	+Differential Receive Signal
S3	RxN	-Differential Receive Signal
S4	GND	
S5	TxN	-Differential Transmit Signal
S6	TxP	+Differential Transmit Signal
S7	GND	

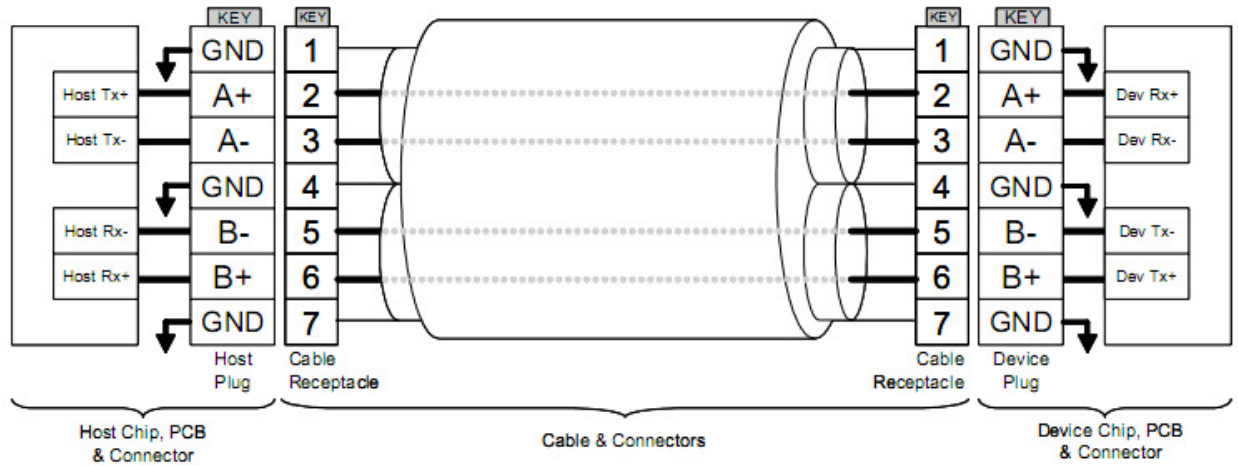

Figure 3-1: SATA Cable/Connector Connection Diagram

The connector on the left represents the Host with TX/RX differential pairs connected to a cable. The connector on the right shows the Device with TX/RX differential pairs also connected to the cable. Notice also the ground path connecting the shielding of the cable to the Cable Receptacle.

## 4. Product Specifications

### 4.1 Capacity

Capacity specification of SDM4-M product family is available as shown in Table 4-1. It lists the specific capacity and the default numbers of heads, sectors and cylinders for each product line.

**Table 4-1:** Capacity specifications

Capacity	Total bytes*	Cylinders	Heads	Sectors	Max LBA
4 GB	4,011,614,208	7,773	16	63	7,835,184
8 GB	8,012,390,400	15,525	16	63	15,649,200
16 GB	16,013,942,784	16,383	16	63	31,277,232
32 GB	32,017,047,552	16,383	16	63	62,533,296

\*Display of total bytes varies from file systems.

\*\*Notes: 1 GB = 1,000,000,000 bytes; 1 sector = 512 bytes.

LBA count addressed in the table above indicates total user storage capacity and will remain the same throughout the lifespan of the device. However, the total usable capacity of the SSD is most likely to be less than the total physical capacity because a small portion of the capacity is reserved for device maintenance usages.

### 4.2 ATA Modes Support

SDM4-M supports the following ATA operating modes:

- Supports up to PIO Mode-4
- Supports up to Multi-word DMA Mode-2
- Supports up to Ultra DMA Mode-5

### 4.3 Performance

Performances of SDM4-M are listed below in table 4-2.

**Table 4-2:** Performance (Typical)

Capacity	4 GB	8 GB	16 GB	32 GB
<b>Performance</b>				
<b>Sustained read (MB/s)</b>	34	38	40	43
<b>Sustained write (MB/s)</b>	6	11	19	21

Note: Results may differ from various flash configurations or host system setting.

---

## 4.4 Environmental Specifications

---

Environmental specification of SDM4-M product family follows MIL-STD-810 standards

**Table 4-3** SDM4-M environmental specifications

Item	Specification
Operating temp.	0~70°C (standard); -40 ~ +85°C (extended)
Non-operating temp.	-40~100(°C)
Vibration (operating)	20~2000(Hz), 7.69(Grms), random wave, x, y, z axis
Vibration (non-operating)	10~2000(Hz), 15(G), sine wave, x, y, z axis
Shock (operating)	50(G), 11(ms), half-sine wave
Shock (non-operating)	1500(G), 0.5(ms), half-sine wave

Note: extended operating temperature specifications are only available for 4, 8, 16GB capacities.

---

## 4.5 Mean Time Between Failures (MTBF)

---

Mean Time Between Failures (MTBF) is predicted based on reliability data for the individual components in SDM4-M. The prediction result for SDM4-M is more than 1,000,000 hours.

Notes about the MTBF:

The MTBF is predicated and calculated based on “Telcordia Technologies Special Report, SR-332, Issue 2” method.

---

## 4.6 Certification and Compliance

---

SDM4-M complies with the following standards:

- CE
- FCC
- RoHS
- MIL-STD-810

---

## **5. Flash Management**

### **5.1 Error Correction/Detection**

---

SDM4-M implements a hardware ECC scheme, based on the BCH algorithm. It can detect and correct up to 16 bits or 24 bits error in 1K bytes.

### **5.2 Bad Block Management**

---

Current production technology is unable to guarantee total reliability of NAND flash memory array. When a flash memory device leaves factory, it comes with a minimal number of initial bad blocks during production or out-of-factory as there is no currently known technology that produce flash chips free of bad blocks. In addition, bad blocks may develop during program/erase cycles. When host performs program/erase command on a block, bad block may appear in Status Register. Since bad blocks are inevitable, the solution is to keep them in control. Apacer flash devices are programmed with ECC, block mapping technique and S.M.A.R.T to reduce invalidity or error. Once bad blocks are detected, data in those blocks will be transferred to free blocks and error will be corrected by designated algorithms.

### **5.3 Wear Leveling**

---

Flash memory devices differ from Hard Disk Drives (HDDs) in terms of how blocks are utilized. For HDDs, when a change is made to stored data, like erase or update, the controller mechanism on HDDs will perform overwrites on blocks. Unlike HDDs, flash blocks cannot be overwritten and each P/E cycle wears down the lifespan of blocks gradually. Repeatedly program/erase cycles performed on the same memory cells will eventually cause some blocks to age faster than others. This would bring flash storages to their end of service term sooner. Wear leveling is an important mechanism that level out the wearing of blocks so that the wearing-down of blocks can be almost evenly distributed. This will increase the lifespan of SSDs. Commonly used wear leveling types are Static and Dynamic.

### **5.4 Power Failure Management**

---

Power Failure Management plays a crucial role when experiencing unstable power supply. Power disruption may occur when users are storing data into the SSD. In this urgent situation, the controller would run multiple write-to-flash cycles to store the metadata for later block rebuilding. This urgent operation requires about several milliseconds to get it done. At the next power up, the firmware will perform a status tracking to retrieve the mapping table and resume previously programmed NAND blocks to check if there is any incompleteness of transmission.

### **5.5 ATA Secure Erase**

---

ATA Secure Erase is an ATA disk purging command currently embedded in most of the storage drives. Defined in ATA specifications, (ATA) Secure Erase is part of Security Feature Set that allows storage drives to erase all user data areas. The erase process usually runs on the firmware level as most of the ATA-based storage media currently in the market are built-in with this command. ATA Secure Erase can securely wipe out the user data in the drive and protects it from malicious attack.

---

## **5.6 S.M.A.R.T.**

---

S.M.A.R.T. is an abbreviation for Self-Monitoring, Analysis and Reporting Technology, a self-monitoring system that provides indicators of drive health as well as potential disk problems. It serves as a warning for users from unscheduled downtime by monitoring and displaying critical drive information. Ideally, this should allow taking proactive actions to prevent drive failure and make use of S.M.A.R.T. information for future product development reference.

Apacer devices use the standard SMART command B0h to read data out from the drive to activate our S.M.A.R.T. feature that complies with the ATA/ATAPI specifications. S.M.A.R.T. Attribute IDs shall include initial bad block count, total later bad block count, maximum erase count, average erase count, power on hours and power cycle. When the S.M.A.R.T. Utility running on the host, it analyzes and reports the disk status to the host before the device reaches in critical condition.

Note: attribute IDs may vary from product models due to various solution design and supporting capabilities.

## **5.7 TRIM**

---

TRIM, though in capital letters usually, is a memory computation command rather than an abbreviation. It is mainly a SATA command that enables the operating system to inform the SSD (Solid State Drive) which blocks of previously stored data are no longer valid, due to erases by the host or operating system, such as file deletions or disk formatting. Once notified, SSD will begin the discard of the invalid LBAs and retain more space for itself, in fact, the discarded is no longer recoverable.

When an LBA is replaced by the operating system, as with overwrite of a file, the SSD is informed that the originally occupied LBA is determined as no longer in use or invalid. The SSD will not save those blocks in garbage collected sectors. Noticeably, a file deletion command by host or operating system never actually erases the actual content, rather, just the file is marked as deleted. This issue is even specifically noticeable for flash based memory devices, such as SSDs. In fact, an SSD will keep garbage collecting the invalid, previously occupied LBAs, if it is not informed that these LBAs can be erased. Thus, the SSD would experience a significant performance downfall.

## 6. Software Interface

### 6.1 Command Set

This section defines the software requirements and the format of the commands the host sends to SDM4-M. Commands are issued to SDM4-M by loading the required registers in the command block with the supplied parameters, and then writing the command code to the Command register.

**Table 6-1:** Command set

Code	Command	Code	Command
E5h	Check Power Mode	F3h	Security Erase Prepare
06h	Data Set Management	F4h	Security Erase Unit
90h	Execute Device Diagnostic	F5h	Security Freeze Lock
E7h	Flush Cache	F1h	Security Set Password
EAh	Flush Cache EXT	F2h	Security Unlock
ECh	Identify Device	70h	Seek
E3h	Idle	EFh	Set Features
E1h	Idle Immediate	C6h	Set Multiple Mode
91h	Initialize Device Parameters	E6h	Sleep
C8h	Read DMA	B0h	SMART
25h	Read DMA EXT	E2h	Standby
C4h	Read Multiple	E0h	Standby Immediate
29h	Read Multiple EXT	CAh	Write DMA
20h	Read Sector	35h	Write DMA EXT
24h	Read Sector EXT	C5h	Write Multiple
40h	Read Verify Sectors	39h	Write Multiple EXT
42h	Read Verify Sectors EXT	30h	Write Sector
10h	Recalibrate	34h	Write Sector EXT
F6h	Security Disable Password		

## 7. Electrical Specification

**Caution: Absolute Maximum Stress Ratings** – Applied conditions greater than those listed under “Absolute Maximum Stress Ratings” may cause permanent damage to the device. This is a stress rating only and functional operation of the device at these conditions or conditions greater than those defined in the operational sections of this data sheet is not implied. Exposure to absolute maximum stress rating conditions may affect device reliability.

**Table 7-1:** Operating range

Range	Ambient Temperature	5V
Standard	0 °C to +70 °C	4.75-5.25V
Extended Temperature	-40 °C to 85 °C	

Note: extended temperature is only available for 4, 8, 16GB capacities of this product family.

**Table 7-2:** Power consumption (typical)

Capacity	4 GB	8 GB	16 GB	32 GB
Modes				
<b>Active (mA)</b>	165	165	185	185
<b>Idle (mA)</b>	85	85	85	85

Note: Results may differ from various flash configurations or platforms.

## 8. Physical Characteristics

### 8.1 Dimensions

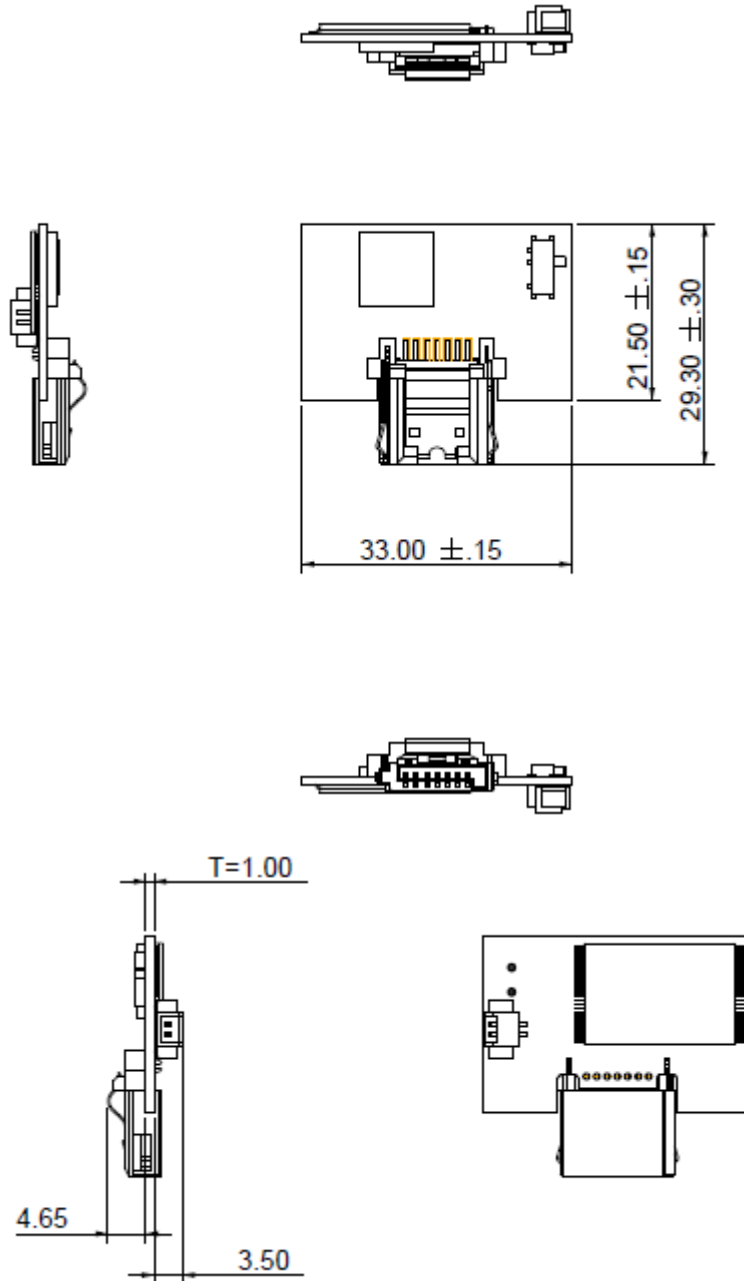

Unit: mm  
Tolerance:  $\pm 0.25$

---

## 8.2 Write Protect Switch (optional)

---

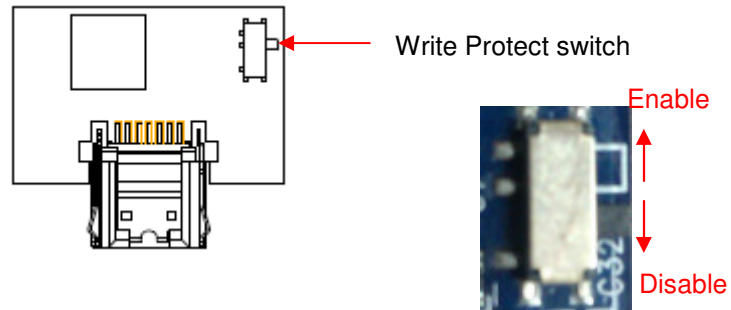

Description of Apacer Write Protect:

Apacer implements the Virtual Write scheme that allows write commands to go through the flash controller and data temporarily stored, but no data has been actually written into the flash. Since the Virtual Write scheme runs at device level, it requires no software or driver installation and is independent from the host OS.

## 9. Product Ordering Information

### 9.1 Product Code Designations

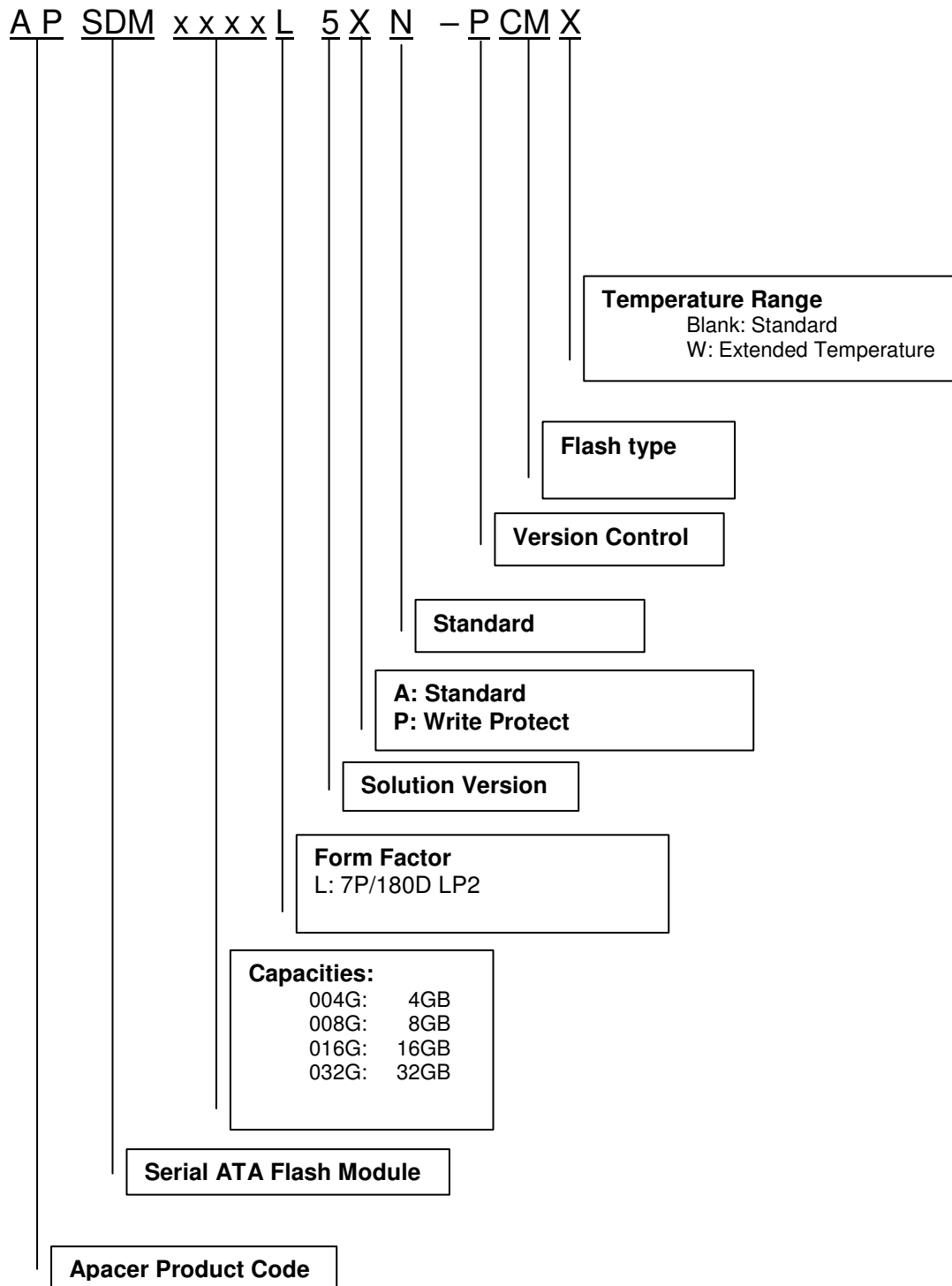

---

## 9.2 Valid Combinations

### 7P/180D LP2 with Write Protect

Capacity	Standard	Extended Temperature
4GB	APSDM004GL5PN-PCM	APSDM004GL5PN-PCMW
8GB	APSDM008GL5PN-PCM	APSDM008GL5PN-PCMW
16GB	APSDM016GL5PN-PCM	APSDM016GL5PN-PCMW
32GB	APSDM032GL5PN-PCM	--

### 7P/180D LP2 without Write Protect

Capacity	Standard	Extended Temperature
4GB	APSDM004GL5AN-PCM	APSDM004GL5AN-PCMW
8GB	APSDM008GL5AN-PCM	APSDM008GL5AN-PCMW
16GB	APSDM016GL5AN-PCM	APSDM016GL5AN-PCMW
32GB	APSDM032GL5AN-PCM	--

---

## Revision History

Revision	Date	Description	Remark
1.0	08/21/2012	Official release	
1.1	11/19/2012	Added details to the Write Protect section	
1.2	10/25/2013	Updated product ordering information due to firmware upgrade	

---

## Global Presence

<b>Taiwan (Headquarters)</b>	<b>Apacer Technology Inc.</b> 1F., No.32, Zhongcheng Rd., Tucheng Dist., New Taipei City 236, Taiwan R.O.C. Tel: 886-2-2267-8000 Fax: 886-2-2267-2261 <a href="mailto:amtsales@apacer.com">amtsales@apacer.com</a>
<b>U.S.A.</b>	<b>Apacer Memory America, Inc.</b> 386 Fairview Way, Suite102, Milpitas, CA 95035 Tel: 1-408-518-8699 Fax: 1-408-935-9611 <a href="mailto:sa@apacerus.com">sa@apacerus.com</a>
<b>Japan</b>	<b>Apacer Technology Corp.</b> 5F, Matsura Bldg., Shiba, Minato-Ku Tokyo, 105-0014, Japan Tel: 81-3-5419-2668 Fax: 81-3-5419-0018 <a href="mailto:jpservices@apacer.com">jpservices@apacer.com</a>
<b>Europe</b>	<b>Apacer Technology B.V.</b> Science Park Eindhoven 5051 5692 EB Son, The Netherlands Tel: 31-40-267-0000 Fax: 31-40-267-0000#6199 <a href="mailto:sales@apacer.nl">sales@apacer.nl</a>
<b>China</b>	<b>Apacer Electronic (Shanghai) Co., Ltd</b> 1301, No.251,Xiaomuqiao Road, Shanghai, 200032, China Tel: 86-21-5529-0222 Fax: 86-21-5206-6939 <a href="mailto:sales@apacer.com.cn">sales@apacer.com.cn</a>
<b>India</b>	<b>Apacer Technologies Pvt Ltd,</b> # 535, 1st Floor, 8th cross, JP Nagar 3rd Phase, Bangalore – 560078, India Tel: 91-80-4152-9061 <a href="mailto:sales_india@apacer.com">sales_india@apacer.com</a>