

***RoHS Recast Compliant***

# **Serial ATA Flash Drive**

***Specifications for SAFD 18P-M***

**June 26<sup>th</sup>, 2013**

***Version 1.9***



***Apacer Technology Inc.***

4<sup>th</sup> Fl., 75 Hsin Tai Wu Rd., Sec.1, Xizhi, New Taipei City, Taiwan 221

Tel: +886-2-2698-2888 Fax: +886-2-2698-2889

[www.apacer.com](http://www.apacer.com)

## Features:

- **Standard Serial ATA Interface**
  - Serial ATA Revision 2.6
  - SATA 3.0 Gbps
  - ATA-compatible command set
  - ATA modes support
- **Capacities**
  - 16, 32, 64, 128, 256 GB
- **Performance\***
  - Burst read/write: 300 MB/sec
  - Sustained read: up to 260 MB/sec
  - Sustained write: up to 160 MB/sec
  - Random read/write: up to 13349 IOPS
  - R/W latency: up to 0.071/0.102 ms
- **Intelligent endurance design**
  - Built-in hardware ECC, enabling up to 16/24 bit correction per 1024 bytes
  - Static wear-leveling scheme together with dynamical block allocation to significantly increase the lifetime of a flash device and optimize the disk performance
  - Flash bad-block management
  - S.M.A.R.T.
  - Power Failure Management
  - ATA Secure Erase
- **NAND Flash Type: MLC**
- **MTBF > 1,000,000 hours**
- **Temperature ranges**
  - Operating:
    - Standard: 0°C to 70°C (32 ~ 158°F)
    - Extended: -40 ~ +85°C (-40° ~ 185°F)\*\*
  - Storage: -40°C to 100°C (-40° ~ 212°F)
- **Supply voltage**
  - 3.3V & 5V
- **Power consumption (Typical)\***
  - Active mode: 820 mA
  - Idle mode: 210 mA
- **Form factor**
  - 1.8 inch SATA Flash Drive (78.5 x 54 x 5, unit: mm)
- **Connector**
  - 7-pin SATA male connector
  - 9-pin SATA power connector
- **Shock & Vibration\*\*\***
  - Shock: 1500 G
  - Vibration: 15 G
- **Endurance\*\*\*\*:**
  - 16 GB: 9.39 TBW
  - 32 GB: 18.78 TBW
  - 64 GB: 37.57 TBW
  - 128 GB: 75.15 TBW
  - 256 GB: 150.30 TBW
- **RoHS Recast compliant\*\*\*\*\***

\*Varies from capacities. The values addressed in the Performance and Power consumption are typical and may vary depending on settings and platforms.

\*\*Only available in 32, 64, 128 and 256GB capacities. Please see "Product Ordering Information" for further details.

\*\*\*At non-operating conditions

\*\*\*\*Endurance is based on TBW (TeraBytes Written).

\*\*\*\*\*Complies with 2011/65/EU standard

---

## Table of Contents

<b>1. Product Description .....</b>	<b>3</b>
1.1 Introduction.....	3
1.2 Functional Block Diagram.....	3
1.3 ATA Mode Support.....	4
1.4 Capacity Specification.....	4
1.5 Performance.....	4
1.6 Pin Assignments .....	5
<b>2. Software Interface .....</b>	<b>7</b>
2.1 Command Set .....	7
2.2 S.M.A.R.T. ....	8
<b>3. Flash Management .....</b>	<b>9</b>
3.1 Error Correction/Detection.....	9
3.2 Flash Block Management.....	9
3.3 Wear Leveling.....	9
3.4 Power Failure Management .....	9
3.5 ATA Secure Erase .....	9
3.6 TRIM.....	9
<b>4. Reliability Specifications .....</b>	<b>11</b>
4.1 Environments.....	11
4.2 Mean Time Between Failures (MTBF).....	11
4.3 Endurance .....	11
4.4 Certification and Compliance .....	12
<b>5. Electrical Characteristics .....</b>	<b>13</b>
5.1 Operating Voltage .....	13
5.2 Power Consumption .....	13
<b>6. Physical Characteristics.....</b>	<b>14</b>
<b>7. Product Ordering Information .....</b>	<b>16</b>
7.1 Product Code Designations .....	16
7.2 Valid Combinations .....	17

# 1. Product Description

## 1.1 Introduction

Apacer's Serial ATA Flash Drive (SAFD) is a solid-state disk (SSD) drive that contains a controller, embedded firmware, and flash media along with a male connector. Using NAND flash memory, the drive transfers data between the host and the storage devices at a radical high speed, making it a great partner for data centers, workstations, KIOSK and servers. Though built with MLC, this SSD can work in highly demanding environment as it can withstand ambient temperature from -40°C to +85°C (for certain capacities only).

SAFD 18P-M drive is designed with a single-chip controller, offering capacities of up to 256 gigabytes and providing full support for the SATA 3.0 Gbps high-speed interface standard. It can operate at sustained transfer rates up to 260 MB/s.

In addition, SAFD 18P-M adopts Global Wear-Leveling scheme to allow uniform use of all storage blocks, ensuring that the lifetime of a flash media can be significantly increased and the disk performance is optimized as well. SAFD 18P-M provides the S.M.A.R.T. feature that follows the SATA Rev. 2.6 specifications and uses the standard SMART command B0h to read data from the drive. This feature protects the user from unscheduled downtime by monitoring and storing critical drive performance.

## 1.2 Functional Block Diagram

SAFD 18P-M drive includes a single-chip SATA Controller and the flash media, as well as the SATA standard interface. The controller integrates the flash management unit with the controller itself to support multi-channel, multi-bank flash arrays. Figure 1-1 shows the functional block diagram.

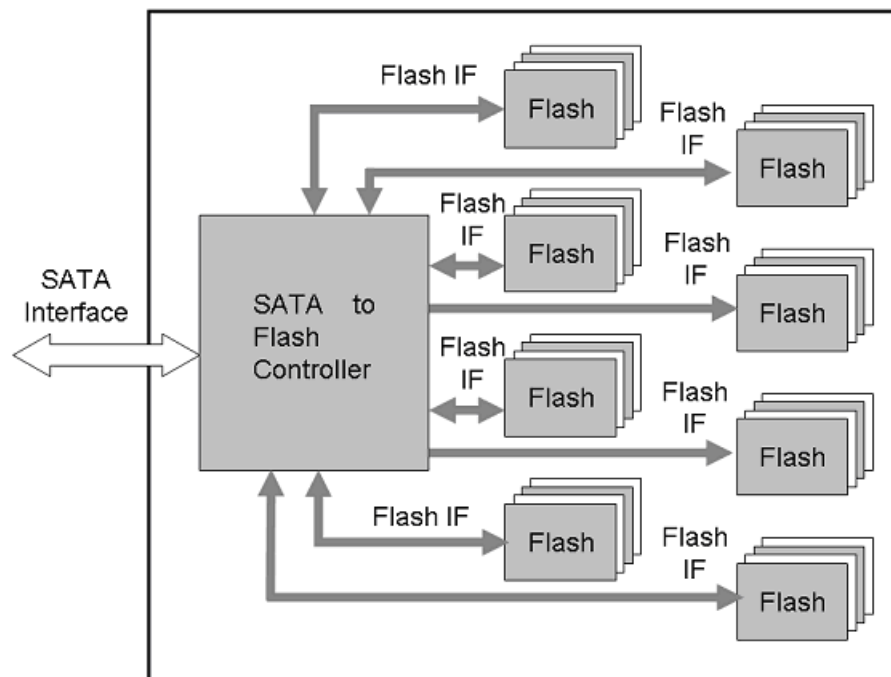

Figure 1-1 Apacer SAFD 18P-M block diagram

### 1.3 ATA Mode Support

SAFD 18P-M provides ATA mode support as follows:

- Up to PIO mode-4
- Up to Multiword DMA mode-2
- Up to UDMA mode-4

### 1.4 Capacity Specification

Capacity specifications (out-of-box/unformatted) of SAFD 18P-M series are available as shown in Table 1-1.

**Table 1-1** Capacity specification

Capacity	Total Bytes	Cylinders	Heads	Sectors	Max LBA*
16 GB	16,013,942,784	16383	16	63	31,277,232
32 GB	32,017,047,752	16,383	16	63	62,533,296
64 GB	64,023,257,088	16,383	16	63	125,045,424
128 GB	128,035,676,160	16,383	16	63	250,069,680
256 GB	253,437,379,584	16,383	16	63	494,994,882

\*Cylinders, heads or sectors are not applicable for these capacities. Only LBA addressing applies.

\*\*Notes: 1 GB = 1,000,000,000 bytes; 1 sector = 512 bytes.

LBA count addressed in the table above indicates total user storage capacity and will remain the same throughout the lifespan of the device. However, the total usable capacity of the SSD is most likely to be less than the total physical capacity because a small portion of the capacity is reserved for device maintenance usages.

### 1.5 Performance

Performances of SAFD 18P-M is shown in Table 1-2.

**Table 1-2** Performance & Random Read/Write 4K specifications

Capacity	16 GB	32 GB	64 GB	128 GB	256 GB
<b>Performance</b>					
<b>Sustained Read (MB/s)</b>	200	220	260	260	250
<b>Sustained Write (MB/s)</b>	50	50	80	160	150
<b>Random Read (IOPS)</b>	13103	13349	12732	12014	11239
<b>Random Write (IOPS)</b>	559	1028	1162	3140	3856
<b>Read Latency (ms)</b>	0.07	0.0699	0.0691	0.0697	0.071
<b>Write Latency (ms)</b>	0.0816	0.081	0.0802	0.0886	0.102

Note:

1. Write Cache enabled
2. Results may vary depending on host system configurations.
3. Sequential Read/Write: The read/write performances are measured by CrystalDiskMark under Windows XP operating system.
4. Random Read/Write: The IOPS number are measured using IOMeter at 8 GB span (16777216 sectors Disk Size), 32 Outstanding I/Os (QD=32), Full Random Data pattern, 4KB Align I/Os and 15-minutes duration.
5. About Latency: the numbers for latency were measured and tested at whole LBA, QD1 (1 Outstanding I/Os), Sequential Read/Write, Full Random Data Pattern, 4KB aligned I/Os and 5-minutes duration.

## 1.6 Pin Assignments

Table 1-3 describes SAFD 18P-M signal segment, and Table1-4, its power segment.

**Figure 1-2** SATA Connectors

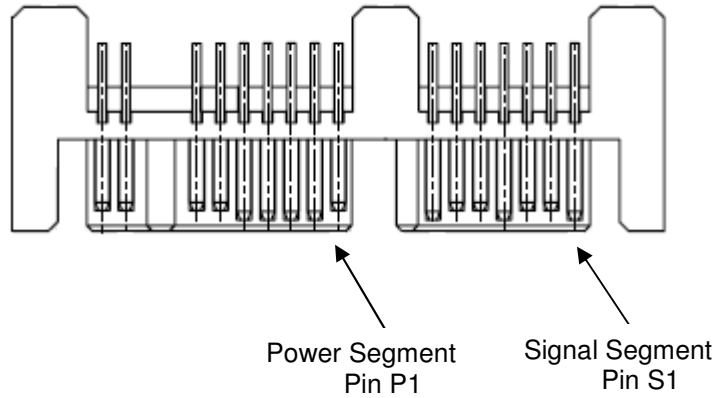

Name	Type	Description
S1	GND	
S2	RxP	+ Differential Receive Signal
S3	RxN	- Differential Receive Signal
S4	GND	
S5	TxN	- Differential Transmit Signal
S6	TxP	+ Differential Transmit Signal
S7	GND	

Pin	Type	Signal/Description
P1	V33	3.3 V Power
P2	V33	3.3 V Power
P3	GND	
P4	GND	
P5	V5	5 V Power
P6	V5	5 V Power
P7	GND	Reserved
P8	Optional	NC
P9	Optional	NC

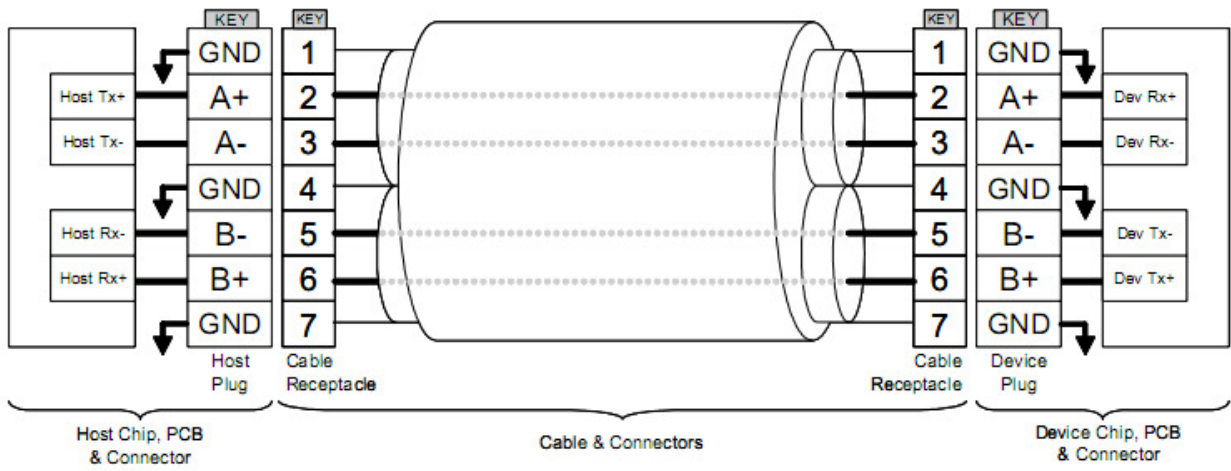

Figure 1-3 SATA Cable/Connector Connection Diagram

The connector on the left represents the Host with TX/RX differential pairs connected to a cable. The connector on the right shows the Device with TX/RX differential pairs also connected to the cable. Notice also the ground path connecting the shielding of the cable to the Cable Receptacle.

## 2. Software Interface

### 2.1 Command Set

Table 2-1 summarizes the ATA commands supported by SAFD 18P-M.

**Table 2-1** Command set

Command	Code
Check-Power-Mode	E5H
Execute-Drive-Diagnostic	90H
Flush-Cache	E7H
Identify-Drive	ECH
Idle	E3H
Idle-Immediate	E1H
Initialize-Drive-Parameters	91H
Read-DMA	C8H or C9H
Read-Multiple	C4H
Read-Sector(s)	20H or 21H
Read-Verify-Sector(s)	40H or 41H
Recalibrate	10H
Security-Disable-Password	F6H
Security-Erase-Prepare	F3H
Security-Erase-Unit	F4H
Security-Freeze-Lock	F5H
Security-Set-Password	F1H
Security-Unlock	F2H
Seek	7XH
Set-Features	EFH
Set-Multiple-Mode	C6H
Sleep	E6H
SMART	B0H
Standby	E2H
Standby-Immediate	E0H
Write-DMA	CAH
Write-Multiple	C5H
Write-Sector(s)	30H

## **2.2 S.M.A.R.T.**

---

S.M.A.R.T. is an abbreviation for Self-Monitoring, Analysis and Reporting Technology, a self-monitoring system that provides indicators of drive health as well as potential disk problems. It serves as a warning for users from unscheduled downtime by monitoring and displaying critical drive information. Ideally, this should allow taking proactive actions to prevent drive failure and make use of S.M.A.R.T. information for future product development reference.

Apacer devices use the standard SMART command B0h to read data out from the drive to activate our S.M.A.R.T. feature that complies with the ATA/ATAPI specifications. S.M.A.R.T. Attribute IDs shall include initial bad block count, total later bad block count, maximum erase count, average erase count, power on hours and power cycle. When the S.M.A.R.T. Utility running on the host, it analyzes and reports the disk status to the host before the device reaches in critical condition.

Note: attribute IDs may vary from product models due to various solution design and supporting capabilities.

---

## 3. Flash Management

### 3.1 Error Correction/Detection

---

SAFD 18P-M implements hardware ECC scheme based on the BCH algorithm which can detect and correct up to 16 bits or 24 bits error in 1024 bytes.

### 3.2 Flash Block Management

---

Current production technology is unable to guarantee total reliability of NAND flash memory array. When a flash memory device leaves factory, it comes with a minimal number of initial bad blocks during production or out-of-factory as there is no currently known technology that produce flash chips free of bad blocks. In addition, bad blocks may develop during program/erase cycles. When host performs program/erase command on a block, bad block may appear in Status Register. Since bad blocks are inevitable, the solution is to keep them in control. Apacer flash devices are programmed with ECC, block mapping technique and S.M.A.R.T to reduce invalidity or error. Once bad blocks are detected, data in those blocks will be transferred to free blocks and error will be corrected by designated algorithms.

### 3.3 Wear Leveling

---

Flash memory devices differ from Hard Disk Drives (HDDs) in terms of how blocks are utilized. For HDDs, when a change is made to stored data, like erase or update, the controller mechanism on HDDs will perform overwrites on blocks. Unlike HDDs, flash blocks cannot be overwritten and each P/E cycle wears down the lifespan of blocks gradually. Repeatedly program/erase cycles performed on the same memory cells will eventually cause some blocks to age faster than others. This would bring flash storages to their end of service term sooner. Wear leveling is an important mechanism that level out the wearing of blocks so that the wearing-down of blocks can be almost evenly distributed. This will increase the lifespan of SSDs. Commonly used wear leveling types are Static and Dynamic.

### 3.4 Power Failure Management

---

Power Failure Management plays a crucial role when experiencing unstable power supply. Power disruption may occur when users are storing data into the SSD. In this urgent situation, the controller would run multiple write-to-flash cycles to store the metadata for later block rebuilding. This urgent operation requires about several milliseconds to get it done. At the next power up, the firmware will perform a status tracking to retrieve the mapping table and resume previously programmed NAND blocks to check if there is any incompleteness of transmission.

Note: The controller unit of this product model is designed with a DRAM as a write cache for improved performance and data efficiency. Though unlikely to happen in most cases, the data cached in the volatile DRAM might be potentially affected if a sudden power loss takes place before the cached data is flushed into non-volatile NAND flash memory.

### 3.5 ATA Secure Erase

---

ATA Secure Erase is an ATA disk purging command currently embedded in most of the storage drives. Defined in ATA specifications, (ATA) Secure Erase is part of Security Feature Set that allows storage drives to erase all user data areas. The erase process usually runs on the firmware level as most of the ATA-based storage media currently in the market are built-in with this command. ATA Secure Erase can securely wipe out the user data in the drive and protects it from malicious attack.

### 3.6 TRIM

---

TRIM, though in capital letters usually, is a memory computation command rather than an abbreviation. It is mainly a SATA command that enables the operating system to inform the SSD (Solid State Drive) which blocks

## Serial ATA Flash Drive APS18P6Axxxx-5CMXX



---

of previously stored data are no longer valid, due to erases by the host or operating system, such as file deletions or disk formatting. Once notified, SSD will begin the discard of the invalid LBAs and retain more space for itself, in fact, the discarded is no longer recoverable.

When an LBA is replaced by the operating system, as with overwrite of a file, the SSD is informed that the originally occupied LBA is determined as no longer in use or invalid. The SSD will not save those blocks in garbage collected sectors. Noticeably, a file deletion command by host or operating system never actually erases the actual content, rather, just the file is marked as deleted. This issue is even specifically noticeable for flash based memory devices, such as SSDs. In fact, an SSD will keep garbage collecting the invalid, previously occupied LBAs, if it is not informed that these LBAs can be erased. Thus, the SSD would experience a significant performance downfall.

## 4. Reliability Specifications

### 4.1 Environments

SAFD 18P-M environmental specifications follow the US Military Standard MIL-STD-810F, as shown in Table 4-1.

**Table 4-1** SAFD 18P-M environmental specifications

Environment	Specification
Temperature	0°C to 70°C (Operating – Standard), -40 ~ +85°C (Operating-extended)* -40°C to 100°C (Non-operating)
Vibration**	Sine wave, 10 ~ 2000Hz Acceleration 15 G, X, Y, Z axis
Shock**	Half sine wave 1500 G, ± X, ±Y, ±Z axis

\*Extended Temperature specification is only available in 32, 64, 128 and 256GB capacities.

\*\*Results addressed here for shock and vibration are at non-operating conditions

### 4.2 Mean Time Between Failures (MTBF)

Mean Time Between Failures (MTBF) is predicted based on reliability data for the individual components in SAFD drive. The prediction result for SAFD 18P-M is more than 1,000,000 hours.

Notes about the MTBF:

The MTBF is predicated and calculated based on “Telcordia Technologies Special Report, SR-332, Issue 2” method

### 4.3 Endurance

Terabytes Written (TBW) is an endurance rating system that indicates the maximum number of terabytes written by the host to the drive. NAND flash has a limit on how many P/E cycles it can withstand before its data retention becomes unreliable. Thus, key factors, such as wear leveling, flash configurations, Write Amplifications and the number of P/E cycles, can influence the lifespan of the drive.

The TBW of the device are listed in the following table.

Capacity	TBW (TB)
16 GB	9.39
32 GB	18.78
64 GB	37.57
128 GB	75.15
256 GB	150.30

Notes:

- The measurement assumes the data written to the SSD for test is under a typical and constant rate.
- The measurement follows the standard metric: 1 TB (Terabyte) = 1000 GB.

---

## 4.4 Certification and Compliance

---

SAFD 18P-M drive complies with the following standards:

- CE
- FCC
- RoHS
- MIL-STD-810F

## 5. Electrical Characteristics

### 5.1 Operating Voltage

Table 5-1 lists the supply voltage for SAFD 18P-M.

**Table 5-1** SAFD 18P-M operating voltage

Parameter	Conditions
Supply voltage	3.3V $\pm$ 5% (3.135-3.465V) / 5V $\pm$ 5% (4.75-5.25V)

### 5.2 Power Consumption

The following table displays the power consumption information for capacities of SAFD 18P-M.

**Table 5-2** SAFD 18P-M power consumption (Typical)

Mode	Capacity	16 GB	32 GB	64 GB	128 GB	256 GB
<b>Active Mode (mA)</b>		270	500	550	790	820
<b>Idle Mode (mA)</b>		190	200	200	210	210

Note: power consumption may vary depending on flash configuration or voltage supply from platforms.

## 6. Physical Characteristics

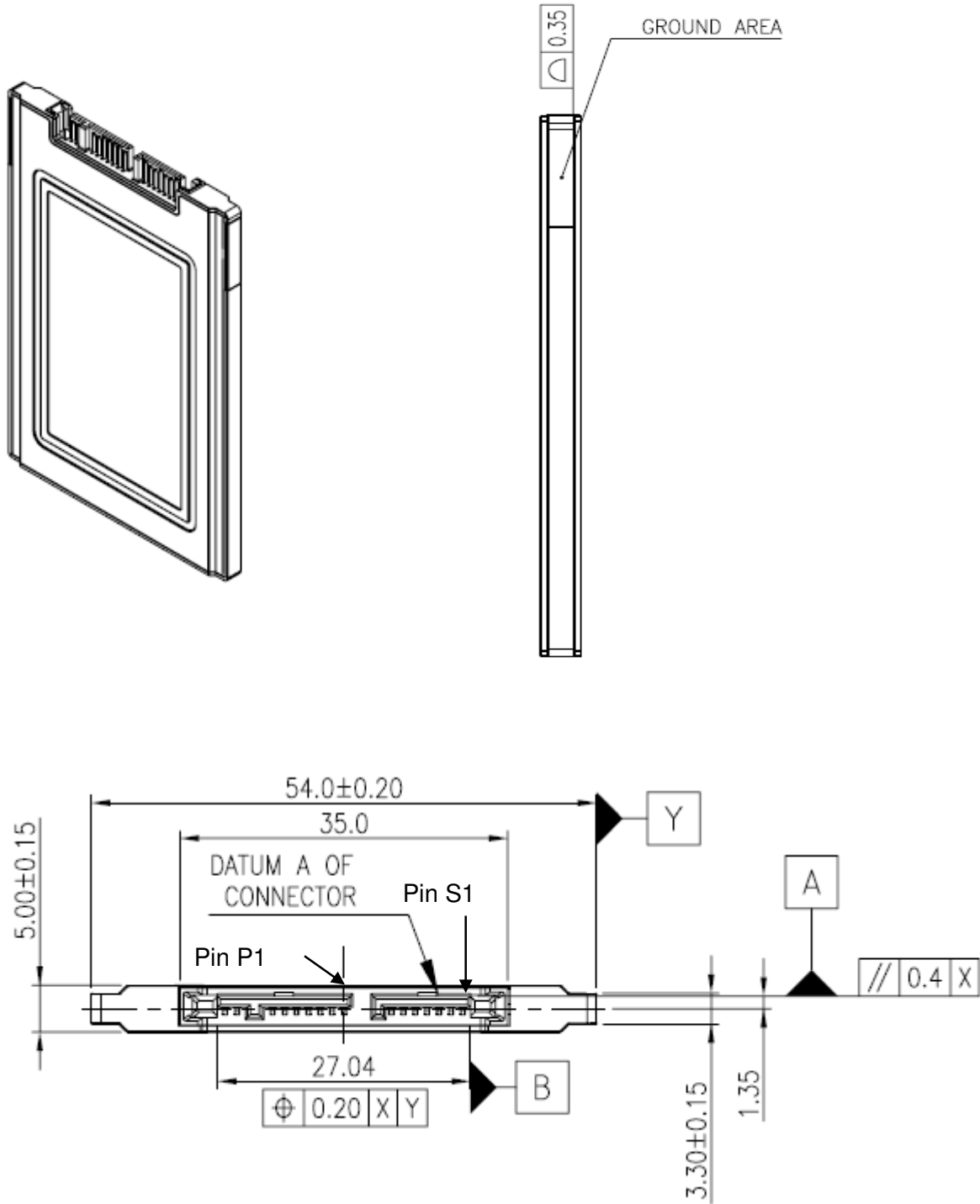

Unit: mm  
 Tolerance:  $\pm 0.2$

Serial ATA Flash Drive  
APS18P6Axxxx-5CMXX

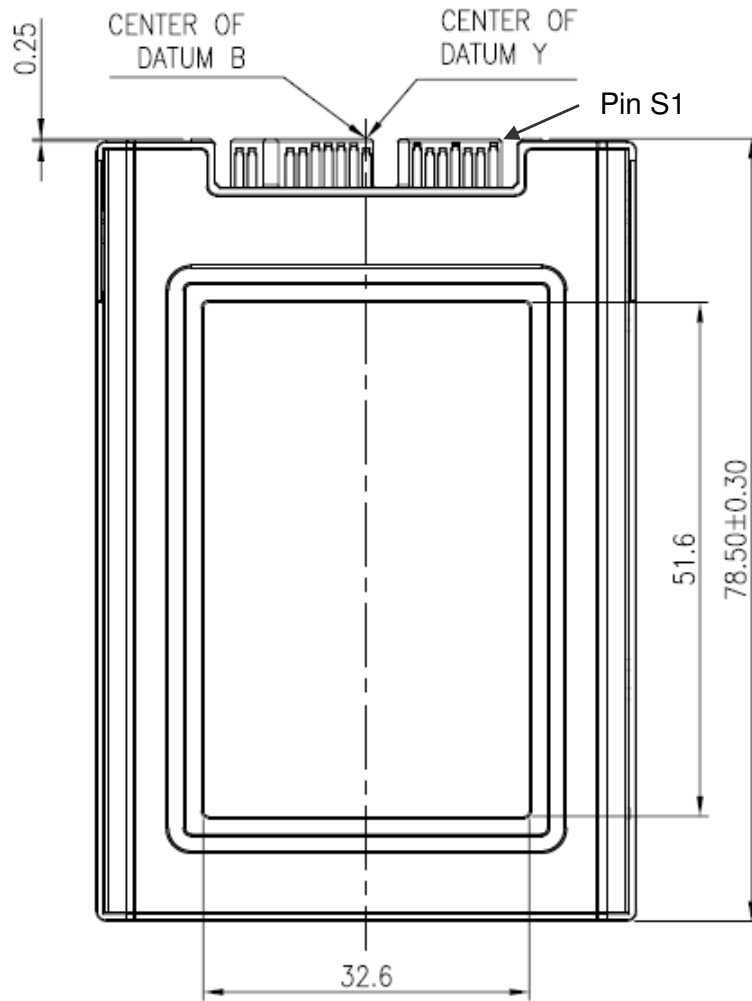

Unit: mm  
Tolerance: ± 0.2

## 7. Product Ordering Information

### 7.1 Product Code Designations

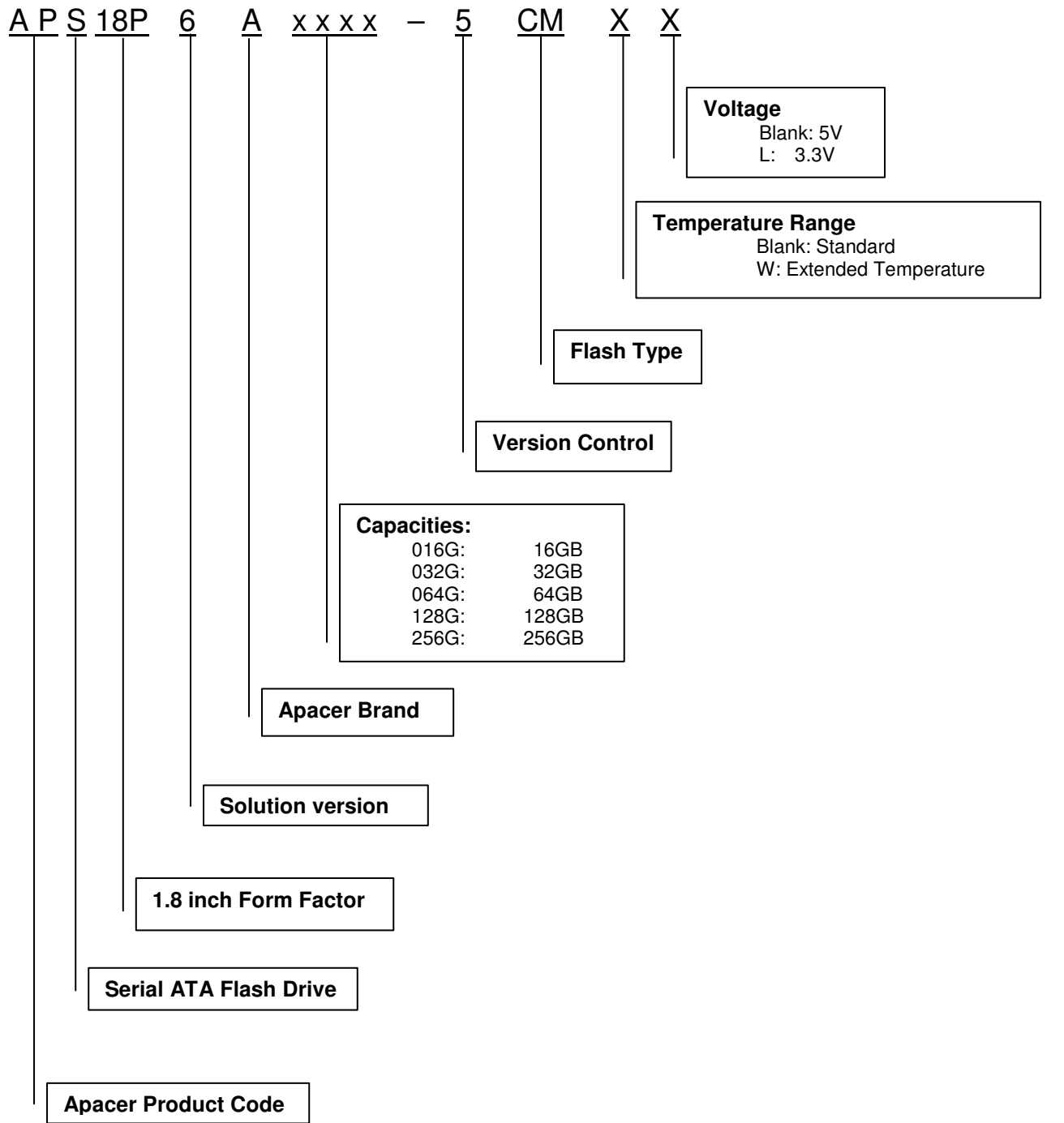

---

## 7.2 Valid Combinations

---

### SAFD18P (voltage: 5V)

Capacity	Standard	Extended Temperature
16 GB	APS18P6A016G-5CM	--
32 GB	APS18P6A032G-5CM	APS18P6A032G-5CMW
64 GB	APS18P6A064G-5CM	APS18P6A064G-5CMW
128 GB	APS18P6A128G-5CM	APS18P6A128G-5CMW
256 GB	APS18P6A256G-5CM	APS18P6A256G-5CMW

### SAFD18P (voltage: 3.3V)

Capacity	Standard	Extended Temperature
16 GB	APS18P6A016G-5CML	--
32 GB	APS18P6A032G-5CML	APS18P6A032G-5CMWL
64 GB	APS18P6A064G-5CML	APS18P6A064G-5CMWL
128 GB	APS18P6A128G-5CML	APS18P6A128G-5CMWL
256 GB	APS18P6A256G-5CML	APS18P6A256G-5CMWL

Note: Please consult with Apacer sales representatives for availabilities.

## Revision History

Revision	Description	Date
0.1	Preliminary release	01/19/2010
1.0	Official release	08/05/2011
1.1	Version updates <ul style="list-style-type: none"> <li>• Corrected power consumption</li> <li>• Added electrostatic discharge and electrical fast transient/burst</li> <li>• Added shock and vibration on the Feature page</li> <li>• Temperatures in Fahrenheit are added on the Feature page</li> </ul>	11/07/2011
1.2	Version updates <ul style="list-style-type: none"> <li>• Updated performance and power consumption</li> <li>• Updated address for our European base</li> <li>• Updated POI</li> </ul>	11/11/2011
1.3	Version updates <ul style="list-style-type: none"> <li>• Extended operating temperature</li> </ul>	11/30/2011
1.4	Version updates <ul style="list-style-type: none"> <li>• Revised S.M.A.R.T information</li> </ul>	03/23/2012
1.5	Version updates <ul style="list-style-type: none"> <li>• Added Endurance sub-section</li> <li>• Added Random read/write 4K data</li> </ul>	05/03/2012
1.6	Version updates <ul style="list-style-type: none"> <li>• Updated TBW section</li> <li>• Updated Random read/write 4K data</li> <li>• Added Read/Write latency</li> <li>• Revised Environmental specifications</li> </ul>	05/23/2012
1.7	Updated Product Ordering Information due to firmware upgrade	11/09/2012
1.8	Version updates: <ul style="list-style-type: none"> <li>• Extended operating temperature is available for 256GB</li> <li>• Environmental compliance: from RoHS to RoHS Recast</li> <li>• Added notes for power failure management</li> </ul>	12/17/2012
1.9	Updated Product Ordering Information due to firmware upgrade	06/26/2013

---

## Global Presence

<b>Taiwan (Headquarters)</b>	<b>Apacer Technology Inc.</b> 4 <sup>th</sup> Fl., 75 Hsin Tai Wu Rd., Sec.1 Xizhi, New Taipei City Taiwan 221 R.O.C. Tel: +886-2-2698-2888 Fax: +886-2-2698-2889 <a href="mailto:amtsales@apacer.com">amtsales@apacer.com</a>
<b>U.S.A.</b>	<b>Apacer Memory America, Inc.</b> 386 Fairview Way, Suite102, Milpitas, CA 95035 Tel: 1-408-518-8699 Fax: 1-408-935-9611 <a href="mailto:sa@apacerus.com">sa@apacerus.com</a>
<b>Japan</b>	<b>Apacer Technology Corp.</b> 5F, Matsura Bldg., Shiba, Minato-Ku Tokyo, 105-0014, Japan Tel: 81-3-5419-2668 Fax: 81-3-5419-0018 <a href="mailto:jpservices@apacer.com">jpservices@apacer.com</a>
<b>Europe</b>	<b>Apacer Technology B.V.</b> Science Park Eindhoven 5051 5692 EB Son, The Netherlands Tel: 31-40-267-0000 Fax: 31-40-267-0000#6199 <a href="mailto:sales@apacer.nl">sales@apacer.nl</a>
<b>China</b>	<b>Apacer Electronic (Shanghai) Co., Ltd</b> 1301, No.251,Xiaomuqiao Road, Shanghai, 200032, China Tel: 86-21-5529-0222 Fax: 86-21-5206-6939 <a href="mailto:sales@apacer.com.cn">sales@apacer.com.cn</a>
<b>India</b>	<b>Apacer Technologies Pvt Ltd,</b> # 535, 1st Floor, 8th cross, JP Nagar 3rd Phase, Bangalore – 560078, India Tel: 91-80-4152-9061 <a href="mailto:sales_india@apacer.com">sales_india@apacer.com</a>