

***RoHS Compliant***

# **SATA-Disk Chip II**

***Specification***

**Jun 3, 2011**

***Version 1.4***



***Apacer Technology Inc.***

4<sup>th</sup> Fl., 75 Hsin Tai Wu Rd., Sec.1 Hsichih, New Taipei City, Taiwan 221

Tel: +886-2-2698-2888 Fax: +886-2-2698-2889

[www.apacer.com](http://www.apacer.com)

## Features:

- **Standard Serial ATA 2.6 (Gen. 2)**
  - Serial ATA 2.6 (Gen. 2)
  - SATA II , 3.0 Gbps
  - ATA command set compatible
- **Connector type**
  - Standard 32/18 pin 600mil DIP
- **Low power consumption (typical)**
  - Supply voltage: 3.3V
  - Active mode: 300 mA
  - Idle mode: 197 mA
- **Performance**
  - Burst transfer rate: 300 MB/sec
  - Sustained read: 53 MB/sec
  - Sustained write: 45 MB/sec
- **Capacity**
  - 1, 2, 4, 8 GB
- **NAND Flash Type: SLC**
- **Temperature ranges**
  - Operation:
    - Standard: 0°C to 70°C
    - Extended Temperature: -40°C to 85°C
  - Storage: -40°C to 100°C
- **Intelligent endurance design**
  - Built-in hardware BCH ECC, correcting 8-bit or 15-bit error per 512-byte data sector
  - Static Wear-Leveling scheme together with dynamical block allocation to significantly increase the lifetime of a flash device and optimize the disk performance
  - Flash Bad-Block Management
  - Power Failure Management
  - ATA Secure Erase
  - S.M.A.R.T. technology
- **RoHS compliant**

---

## Table of Contents

|  |           |
|--|-----------|
| <b>1. GENERAL DESCRIPTION .....</b>          | <b>3</b>  |
| <b>2. FUNCTIONAL BLOCK .....</b>             | <b>4</b>  |
| 2.1 FUNCTIONAL SPECIFICATIONS.....           | 4         |
| 2.1.1 ATA Mode Support .....                 | 4         |
| 2.1.2 Performance .....                      | 4         |
| 2.1.3 Capacity Specification .....           | 5         |
| 2.2 ENVIRONMENTAL SPECIFICATIONS .....       | 5         |
| <b>3. PIN ASSIGNMENTS .....</b>              | <b>6</b>  |
| 3.1 32 PINS (16 X 2).....                    | 6         |
| 3.2 18 PINS (7X2 + 2X2).....                 | 7         |
| <b>4. FLASH MANAGEMENT .....</b>             | <b>8</b>  |
| 4.1 ERROR CORRECTION/DETECTION.....          | 8         |
| 4.2 BAD BLOCK MANAGEMENT .....               | 8         |
| 4.3 WEAR LEVELING .....                      | 8         |
| 4.4 POWER FAILURE MANAGEMENT.....            | 8         |
| 4.5 ATA SECURE ERASE .....                   | 8         |
| 4.6 S.M.A.R.T. TECHNOLOGY.....               | 9         |
| <b>5. SOFTWARE INTERFACE .....</b>           | <b>10</b> |
| 5.1 COMMAND SET .....                        | 10        |
| <b>6. PHYSICAL CHARACTERISTICS .....</b>     | <b>12</b> |
| 6.1 DIMENSION OF 32 PINS (16X2).....         | 12        |
| 6.2 DIMENSION OF 18 PINS (7X2 + 2X2).....    | 14        |
| <b>7. PRODUCT ORDERING INFORMATION .....</b> | <b>16</b> |
| 7.1 PRODUCT CODE DESIGNATIONS .....          | 16        |
| 7.2 VALID COMBINATIONS .....                 | 17        |

---

## 1. General Description

Apacer's SATA-Disk Chip (SDC) is a high performance, embedded flash memory data storage system. This product is designed for embedded flash storage applications with expanded functionality and is a cost-effective replacement for a conventional IDE hard disk drive. SDCs have a built-in micro-controller and file management firmware that communicates with SATA standard interfaces; therefore, SDCs do not require additional or proprietary host software such as Flash File System (FFS) and Memory Technology Driver (MTD) software. Packaged in a 600 mil 32 or 18 round pin DIP package for easy and cost-effective mounting to a system motherboard, SDCs are designed to work at 3.3 Volts and use a standard SATA driver that is part of all major operating systems such as Microsoft's Windows series, Apple's MAC OS family, and UNIX variants.

In addition to buffer management through dynamical allocation, SDC adopts the static wear-leveling scheme to allow uniform use of all storage blocks, ensuring that the lifetime of a flash media can be significantly increased and the disk performance is optimized as well. SDC provides the S.M.A.R.T. feature complies to the SATA Rev.2.6, ATA/ATAPI-7 specifications and uses the standard SMART command B0h to read data from the drive. This feature protects the user from unscheduled downtime by monitoring and storing critical drive performance.

## 2. Functional Block

The SATA-Disk Chip (SDC) includes the SATA and Flash Management controllers, and flash media, as well as the SATA standard interface. Figure 2-1 shows the functional block diagram.

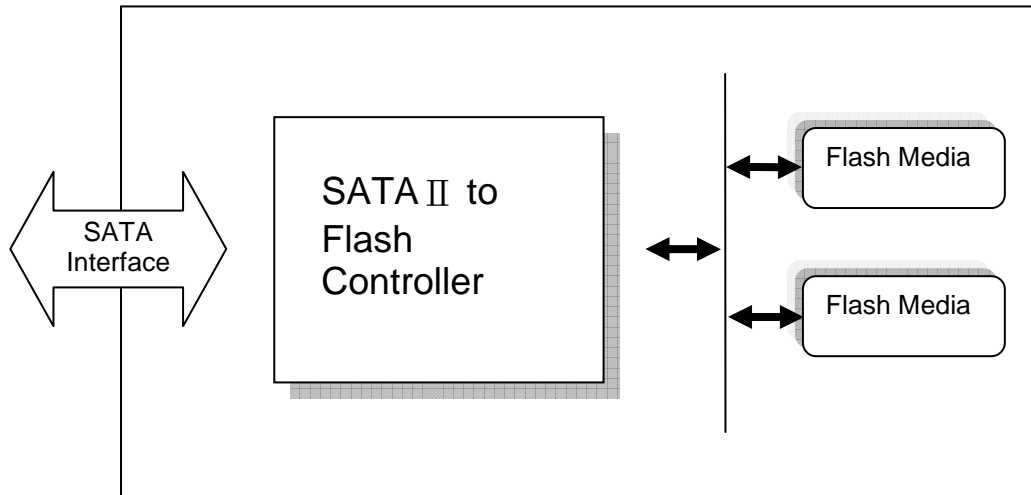

**Figure 2-1:** Functional block diagram

### 2.1 Functional Specifications

#### 2.1.1 ATA Mode Support

The SATA-Disk Chip supports the following ATA operating modes:

- Supports up to PIO Mode-4
- Supports up to Multi-word DMA Mode-2
- Supports up to Ultra DMA Mode-5

#### 2.1.2 Performance

Performance of SATA-Disk Chip is shown in table 2-1

**Table 2-1:** Performance specifications

| Capacity                      | 1 GB | 2 GB | 4 GB | 8 GB |
|-------------------------------|------|------|------|------|
| <b>Performance</b>            |      |      |      |      |
| <b>Sustained read (MB/s)</b>  | 27   | 27   | 53   | 53   |
| <b>Sustained write (MB/s)</b> | 12   | 22   | 45   | 45   |

Note: Performances vary from flash configurations.

### 2.1.3 Capacity Specification

Capacity specification of the SDC product family is available as shown in Table 2-2. It lists the specific capacity, the default numbers of logical cylinders and heads, and the number of logical sectors per track for each product line.

**Table 2-2** Capacity specification

| Capacity | Total Bytes   | Cylinders | Heads | Sectors | Max LBA    |
|----------|---------------|-----------|-------|---------|------------|
| 1 GB     | 992,968,704   | 1,924     | 16    | 63      | 1,939,392  |
| 2 GB     | 2,002,452,480 | 3,880     | 16    | 63      | 3,911,040  |
| 4 GB     | 4,021,936,128 | 7,793     | 16    | 63      | 7,855,344  |
| 8 GB     | 8,061,419,520 | 15,620    | 16    | 63      | 15,744,960 |

### 2.2 Environmental Specifications

Environmental specification of the SATA-Disk Chip (SDC) product family which follows the MIL-STD-810F standards is available as shown in Table 2-3.

**Table 2-3:** Environmental specifications

| Environment               |           | Specification  |
|---------------------------|-----------|--|
| Temperature               | Operation | 0°C to 70°C (Standard) ; -40°C to 85°C (E xtended Temperature)       |
|                           | Storage   | -40°C to 100°C   |
| Humidity                  |           | 5% to 95% RH (Non-condensing)  |
| Vibration (Non-Operation) |           | Sine wave: 20~2000Hz, 16.3g (X, Y, Z axes)                           |
| Shock (Non-Operation)     |           | Half sine wave, Peak acceleration 50 G, 11 ms (X, Y, Z ; All 6 axes) |

## 3. Pin Assignments

### 3.1 32 pins (16 x 2)

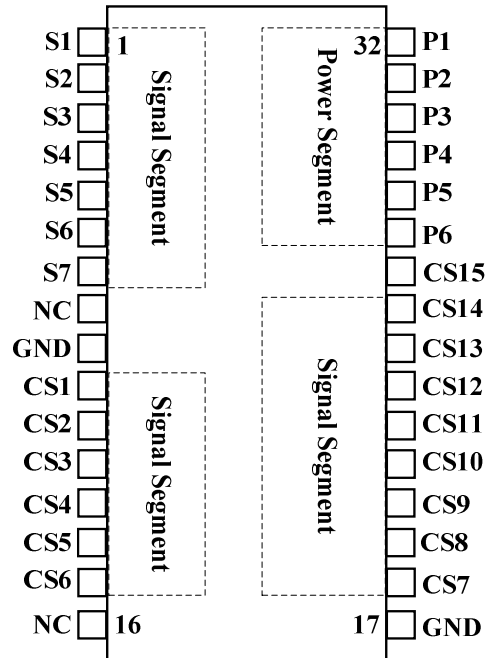

| Pin | Name | Type*   | Pin | Name | Type*     |
|-----|------|---------|-----|------|-----------|
| 1   | S1   | GND     | 17  | GND  | GND       |
| 2   | S2   | RX+     | 18  | CS7  | Data Act. |
| 3   | S3   | RX-     | 19  | CS8  | RS        |
| 4   | S4   | GND     | 20  | CS9  | RS        |
| 5   | S5   | TX-     | 21  | CS10 | RS        |
| 6   | S6   | TX+     | 22  | CS11 | RS        |
| 7   | S7   | GND     | 23  | CS12 | RS        |
| 8   | NC   | -       | 24  | CS13 | RS        |
| 9   | GND  | GND     | 25  | CS14 | RS        |
| 10  | CS1  | RS1     | 26  | CS15 | RS/WP     |
| 11  | CS2  | RS      | 27  | P6   | NA/UGND   |
| 12  | CS3  | RS      | 28  | P5   | NA/USB+   |
| 13  | CS4  | RS      | 29  | P4   | NA/USB-   |
| 14  | CS5  | RS      | 30  | P3   | NA/UVCC   |
| 15  | CS6  | PHY RDY | 31  | P2   | GND       |
| 16  | NC   | -       | 32  | P1   | VCC3.3    |

\*RS: Reserved

# SATA-Disk Chip II

## AP-SDCxxxxXQANS-XXHT

### 3.2 18 pins (7x2 + 2x2)

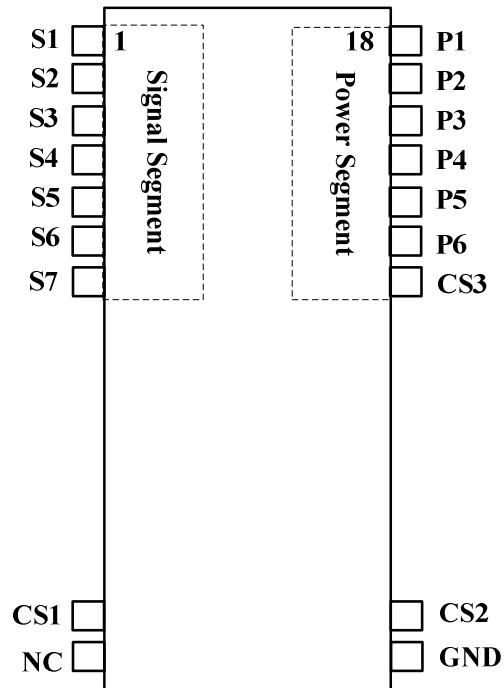

| Pin | Name | Type*   | Pin | Name | Type*     |
|-----|------|---------|-----|------|-----------|
| 1   | S1   | GND     | 10  | GND  | GND       |
| 2   | S2   | RX+     | 11  | CS2  | Data Act. |
| 3   | S3   | RX-     | 12  | CS3  | RS/WP     |
| 4   | S4   | GND     | 13  | P6   | NA/UGND   |
| 5   | S5   | TX-     | 14  | P5   | NA/USB+   |
| 6   | S6   | TX+     | 15  | P4   | NA/USB-   |
| 7   | S7   | GND     | 16  | P3   | NA/UVCC   |
| 8   | CS1  | PHY RDY | 17  | P2   | GND       |
| 9   | NC   | -       | 18  | P1   | VCC3.3    |

\*RS: Reserved

---

## 4. Flash Management

### 4.1 Error Correction/Detection

---

SDC implements a hardware ECC scheme, based on the BCH algorithm. It can detect and correct up to 8 bits or 15 bits error in 512 bytes.

### 4.2 Bad Block Management

---

Although bad blocks on the flash media are already identified by the flash manufacturer, they can also be accumulated over time during operation. SDC's controller maintains a table that lists those normal blocks with disk data, the free blocks for wear leveling, and bad blocks with errors. When a normal block is detected broken, it is replaced with a free block and listed as a bad block. When a free block is detected broken, it is then removed from the free block list and marked as a bad block.

During device operation, this ensures that newly accumulated bad blocks are transparent to the host. The device will stop file write service once there are only two free blocks left such that the read function is still available for copying the files from the disk into another.

### 4.3 Wear Leveling

---

The NAND flash devices are limited by a certain number of write cycles. When using a FAT-based file system, frequent FAT table updates are required. If some area on the flash wears out faster than others, it would significantly reduce the lifetime of the whole SSD, even if the erase counts of others are far from the write cycle limit. Thus, if the write cycles can be distributed evenly across the media, the lifetime of the media can be prolonged significantly. This scheme is called wear leveling.

Apacer's wear-leveling scheme is achieved both via buffer management and Apacer-specific static wear leveling. They both ensure that the lifetime of the flash media can be increased, and the disk access performance is optimized as well.

### 4.4 Power Failure Management

---

The Low Power Detection on the controller initiates crucial data saving before the power supplied to the device is too low. This feature prevents the device from crash and ensures data integrity during an unexpected power-off.

### 4.5 ATA Secure Erase

---

Accomplished by the Secure Erase (SE) command, which added to the open ANSI standards that control disk drives, "ATA Secure Erase" is built into the disk drive itself and thus far less susceptible to malicious software attacks than external software utilities. It is a positive easy-to-use data destroy command, amounting to electronic data shredding. Executing the command causes a drive to internally completely erase all possible user data. This command is carried out within disk drives, so no additional software is required. Once executed, neither data nor the erase counter on the device would be recoverable, which blurs the accuracy of device lifespan. The process to erase will not be stopped until finished while encountering power failure, and will be continued when power is back on.

---

## **4.6 S.M.A.R.T. Technology**

---

S.M.A.R.T. is an acronym for Self-Monitoring, Analysis and Reporting Technology, an open standard allowing disk drives to automatically monitor their own health and report potential problems. It protects the user from unscheduled downtime by monitoring and storing critical drive performance and calibration parameters. Ideally, this should allow taking proactive actions to prevent impending drive failure.

Apacer's SDC uses the standard SMART command B0h to read data from the drive for SMART feature as the SATA Rev.2.6 ATA/ATAPI-7 specifications. Based on the SFF-8035i Rev. 2.0 specifications, Apacer SMART defines 3 vendor-specified SMART Attribute IDs (E5h, EAh-EBh, and E8h) in the SDC. They represent Flash ID, maximum erase count, average erase count, good block count, free-list block count, and firmware version information. When the Apacer SMART Utility running on the host, it analyzes and reports the disk status to the host before the SDC is in critical condition.

## 5. Software Interface

### 5.1 Command Set

This section defines the software requirements and the format of the commands the host sends to the SATA-Disk Chip (SDC). Commands are issued to the SDC by loading the required registers in the command block with the supplied parameters, and then writing the command code to the Command register.

**Table 5-1:** Command set (1 of 2)

| Command                     | Code       | FR <sup>1</sup> | SC <sup>2</sup> | SN <sup>3</sup> | CY <sup>4</sup> | DH <sup>5</sup> | LBA <sup>6</sup> |
|-----------------------------|------------|-----------------|-----------------|-----------------|-----------------|-----------------|------------------|
| Check-Power-Mode            | E5H        | -               | -               | -               | -               | D <sup>8</sup>  | -                |
| Execute-Drive-Diagnostic    | 90H        | -               | -               | -               | -               | D               | -                |
| Flush-Cache                 | E7H        | -               | -               | -               | -               | D               | -                |
| Identify-Drive              | ECH        | -               | -               | -               | -               | D               | -                |
| Idle                        | E3H        | -               | Y               | -               | -               | D               | -                |
| Idle-Immediate              | E1H        | -               | -               | -               | -               | D               | -                |
| Initialize-Drive-Parameters | 91H        | -               | Y               | -               | -               | Y               | -                |
| Read-DMA                    | C8H or C9H | -               | Y               | Y               | Y               | Y               | Y                |
| Read-Multiple               | C4H        | -               | Y               | Y               | Y               | Y               | Y                |
| Read-Sector(s)              | 20H or 21H | -               | Y               | Y               | Y               | Y               | Y                |
| Read-Verify-Sector(s)       | 40H or 41H | -               | Y               | Y               | Y               | Y               | Y                |
| Recalibrate                 | 10H        | -               | -               | -               | -               | D               | -                |
| Security-Disable-Password   | F6H        | -               | -               | -               | -               | D               | -                |
| Security-Erase-Prepare      | F3H        | -               | -               | -               | -               | D               | -                |
| Security-Erase-Unit         | F4H        | -               | -               | -               | -               | D               | -                |
| Security-Freeze-Lock        | F5H        | -               | -               | -               | -               | D               | -                |
| Security-Set-Password       | F1H        | -               | -               | -               | -               | D               | -                |
| Security-Unlock             | F2H        | -               | -               | -               | -               | D               | -                |
| Seek                        | 7XH        | -               | -               | -               | Y               | Y               | -                |
| Set-Features                | EFH        | Y <sup>7</sup>  | -               | -               | -               | D               | -                |

**SATA-Disk Chip II**  
**AP-SDCxxxxXQANS-XXHT**



**Table 5-1:** Command set (2 of 2)

| Command           | Code | FR <sup>1</sup> | SC <sup>2</sup> | SN <sup>3</sup> | CY <sup>4</sup> | DH <sup>5</sup> | LBA <sup>6</sup> |
|-------------------|------|-----------------|-----------------|-----------------|-----------------|-----------------|------------------|
| Set-Multiple-Mode | C6H  | -               | Y               | -               | -               | D               | -                |
| Sleep             | E6H  | -               | -               | -               | -               | D               | -                |
| SMART             | B0H  | Y               | Y               | Y               | Y               | D               |                  |
| Standby           | E2H  | -               | -               | -               | -               | D               | -                |
| Standby-Immediate | E0H  | -               | -               | -               | -               | D               | -                |
| Write-DMA         | CAH  | -               | Y               | Y               | Y               | Y               | Y                |
| Write-Multiple    | C5H  | -               | Y               | Y               | Y               | Y               | Y                |
| Write-Sector(s)   | 30H  | -               | Y               | Y               | Y               | Y               | Y                |

1. FR - Features register
2. SC - Sector Count register
3. SN - Sector Number register
4. CY - Cylinder registers
5. DH - Drive/Head register
6. LBA - Logical Block Address mode supported (see command descriptions for use)
7. Y - The register contains a valid parameter for this command.
8. For the Drive/Head register:  
 Y means both the SDC and Head parameters are used  
 D means only the SDC parameter is valid and not the Head parameter

## 6. Physical Characteristics

### 6.1 Dimension of 32 pins (16x2)

TOP VIEW

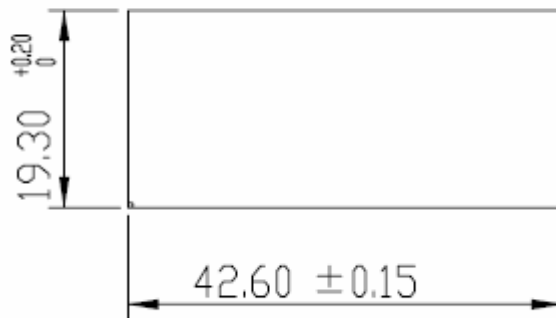

BOTTOM VIEW

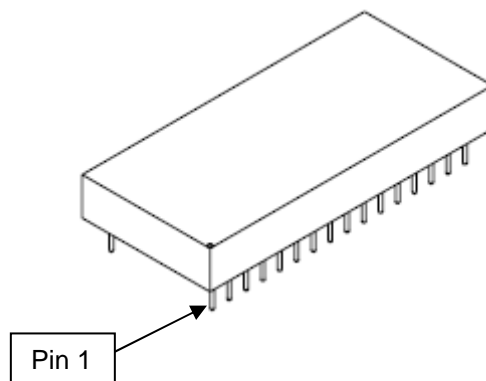
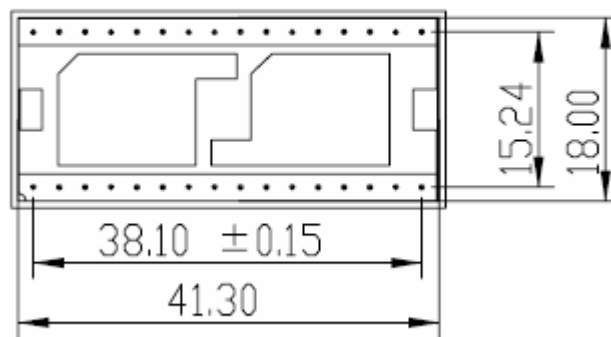

Unit: mm  
Tolerance: ± 0.25

SATA-Disk Chip II  
AP-SDCxxxxXQANS-XXHT

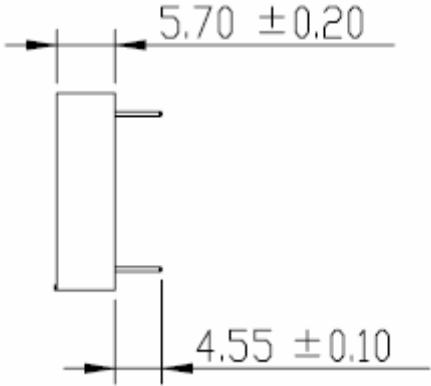
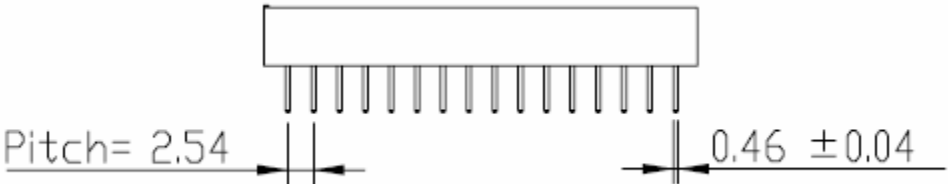

Unit: mm  
Tolerance:  $\pm 0.25$

---

6.2 Dimension of 18 pins (7x2 + 2x2)

---

TOP VIEW

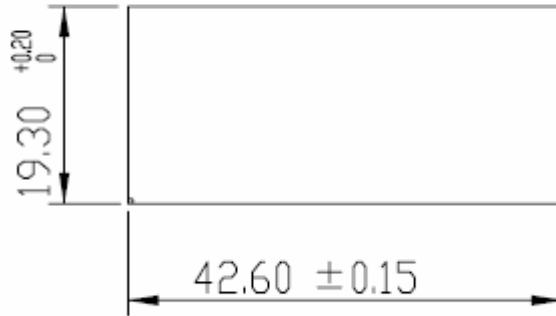

BOTTOM VIEW

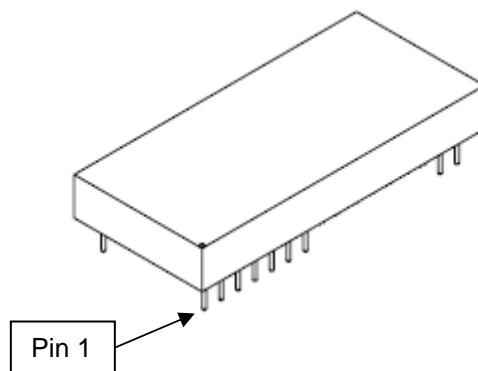
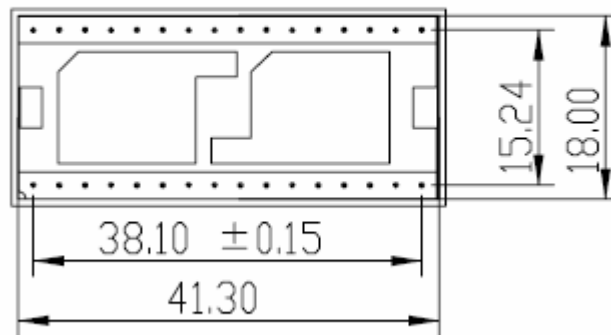

Unit: mm  
Tolerance:  $\pm 0.25$

SATA-Disk Chip II  
AP-SDCxxxxXQANS-XXHT

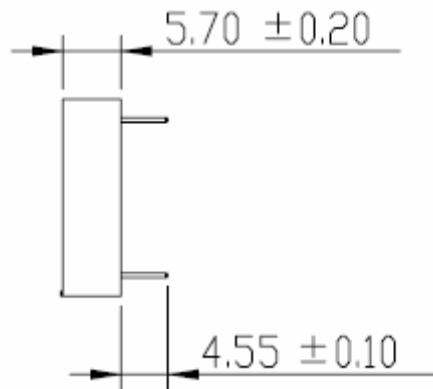
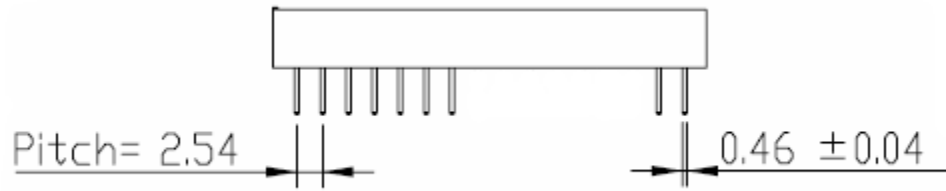

Unit: mm  
Tolerance:  $\pm 0.25$

## 7. Product Ordering Information

### 7.1 Product Code Designations

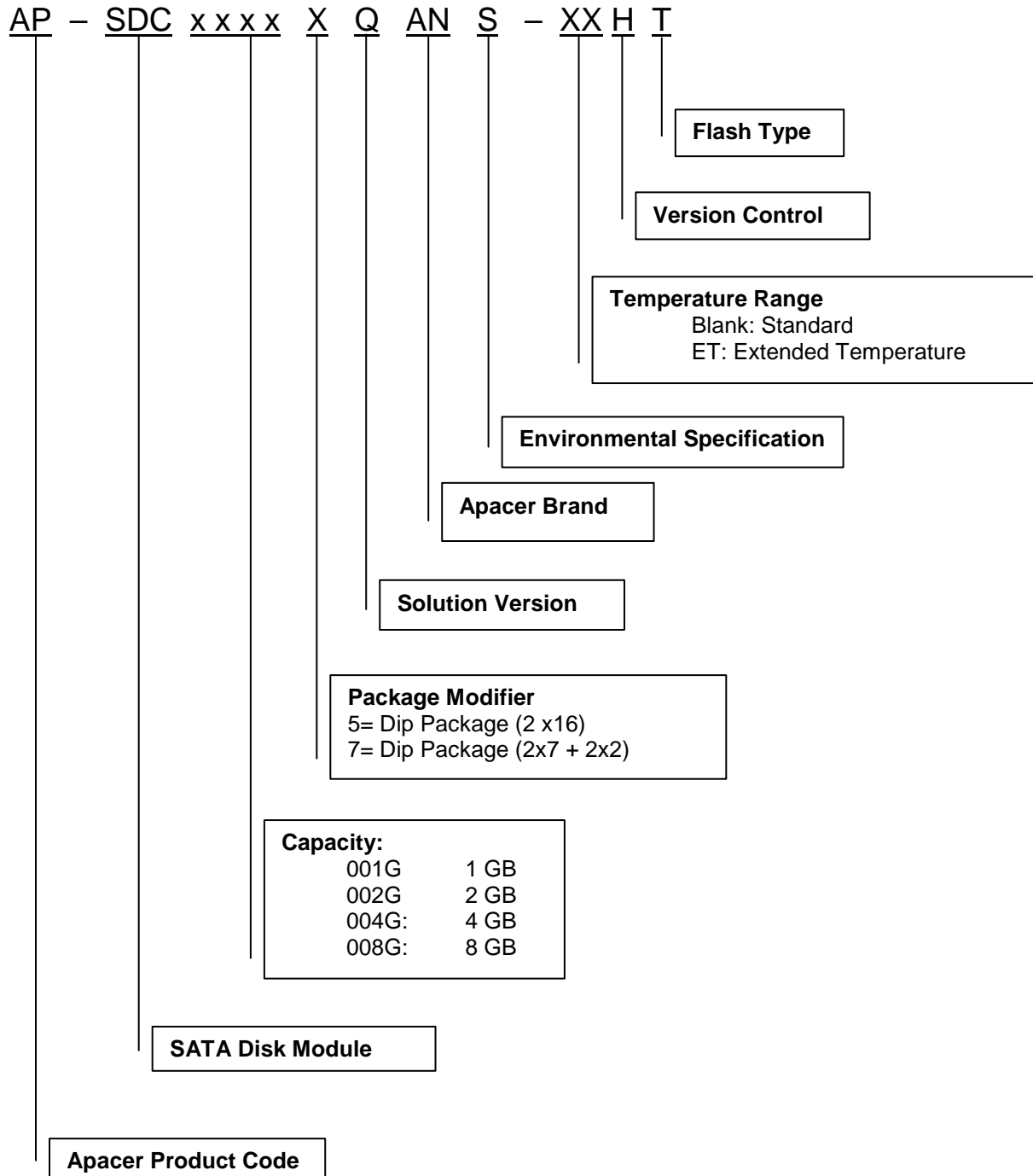

---

## 7.2 Valid Combinations

---

### SDCII 2 x 16 pin

| Capacity | Standard           | Extended Temperature |
|----------|--------------------|----------------------|
| 1GB      | AP-SDC001G5QANS-HT | AP-SDC001G5QANS-ETHT |
| 2GB      | AP-SDC002G5QANS-HT | AP-SDC002G5QANS-ETHT |
| 4GB      | AP-SDC004G5QANS-HT | AP-SDC004G5QANS-ETHT |
| 8GB      | AP-SDC008G5QANS-HT | AP-SDC008G5QANS-ETHT |

### SDCII (2x7 + 2x2) pin

| Capacity | Model Number       | Extended Temperature |
|----------|--------------------|----------------------|
| 1GB      | AP-SDC001G7QANS-HT | AP-SDC001G7QANS-ETHT |
| 2GB      | AP-SDC002G7QANS-HT | AP-SDC002G7QANS-ETHT |
| 4GB      | AP-SDC004G7QANS-HT | AP-SDC004G7QANS-ETHT |
| 8GB      | AP-SDC008G7QANS-HT | AP-SDC008G7QANS-ETHT |

**Note:** Valid combinations are those products in mass production or will be in mass production. Consult your Apacer sales representative to confirm availability of valid combinations and to determine availability of new combinations.

---

## Revision History

| Revision | Date       | Description                                 | Remark |
|----------|------------|---|--------|
| 1.0      | 08/04/2009 | Official release                            |        |
| 1.1      | 08/18/2009 | Updated performance                         |        |
| 1.2      | 11/18/2009 | Supplemented capacity specification details |        |
| 1.3      | 01/18/2011 | Updated product ordering information        |        |
| 1.4      | 06/03/2011 | Revised Environmental Specifications        |        |

---

## Global Presence

|                              |  |
|------------------------------|--|
| <b>Taiwan (Headquarters)</b> | <b>Apacer Technology Inc.</b><br>4 <sup>th</sup> Fl., 75 Xintai 5 <sup>th</sup> Rd., Sec.1<br>Hsichih, New Taipei City<br>Taiwan 221<br>R.O.C.<br>Tel: +886-2-2698-2888<br>Fax: +886-2-2698-2889<br><a href="mailto:amtsales@apacer.com">amtsales@apacer.com</a> |
| <b>U.S.A.</b>                | <b>Apacer Memory America, Inc.</b><br>386 Fairview Way, Suite102,<br>Milpitas, CA 95035<br>Tel: 1-408-518-8699<br>Fax: 1-408-935-9611<br><a href="mailto:sa@apacerus.com">sa@apacerus.com</a>  |
| <b>Japan</b>                 | <b>Apacer Technology Corp.</b><br>5F, Matsura Bldg., Shiba, Minato-Ku<br>Tokyo, 105-0014, Japan<br>Tel: 81-3-5419-2668<br>Fax: 81-3-5419-0018<br><a href="mailto:jpservices@apacer.com">jpservices@apacer.com</a>  |
| <b>Europe</b>                | <b>Apacer Technology B.V.</b><br>Aziëlaan 22,<br>5232 BA 's-Hertogenbosch,<br>The Netherlands<br>Tel: 31-73-645-9620<br>Fax: 31-73-645-9629<br><a href="mailto:sales@apacer.nl">sales@apacer.nl</a>  |
| <b>China</b>                 | <b>Apacer Electronic (Shanghai) Co., Ltd</b><br>1301, No.251,Xiaomujiao Road, Shanghai,<br>200032, China<br>Tel: 86-21-5529-0222<br>Fax: 86-21-5206-6939<br><a href="mailto:sales@apacer.com.cn">sales@apacer.com.cn</a>   |
| <b>India</b>                 | <b>Apacer Technologies Pvt Ltd,</b><br>#1064, 1st Floor, 7th 'A' Main,<br>3rd Block Koramangala, Bangalore – 560 034<br>Tel: +91 80 4152 9061/62/63<br>Fax: +91 80 4170 0215<br><a href="mailto:sales_india@apacer.com">sales_india@apacer.com</a>               |