

*RoHS Compliant*

# **PCI Express Disk Module**

*M.2 PT42 Product Specifications*

**March 22, 2017**

*Version 1.4*



**Apacer Technology Inc.**

1F, No.32, Zhongcheng Rd., Tucheng Dist., New Taipei City, Taiwan, R.O.C

Tel: +886-2-2267-8000 Fax: +886-2-2267-2261

[www.apacer.com](http://www.apacer.com)

## Features:

- **Standard PCI Express Bus Interface**
  - PCI Express Specification Rev.2.0\*
  - PCI Express Card Electromechanical Rev. 2.0
  - PCI Express Gen2 x 2
  - Supports Separate Reference Clock Independent SSC
- **Capacity**
  - 8, 16, 32, 64 GB
- **Performance\*\***
  - Sequential Read Speed up to 540 MB/s
  - Sequential Write Speed up to 180 MB/s
- **Flash Management**
  - Supports ECC up to 72 bit correction per 1K Byte data
  - Global Wear Leveling
  - Flash bad-block management
  - S.M.A.R.T.
  - Power Failure Management
- **NAND Flash: MLC**
- **Temperature Range**
  - Operating: 0°C to 80°C
  - Storage: -40°C to 85°C
- **Supply Voltage**
  - 3.3 V ± 5%
- **Power Consumption\*\***
  - Active mode: 1,025 mA
  - Idle mode: 530 mA
- **Form Factor**
  - M.2 2242-D2-B-M
  - Dimensions: 42.00 x 22.00 x 3.70, unit: mm
- **Supports NCQ (Native Command Queue) Commands**
- **Supports AHCI Programming Interface**
- **Supports UEFI Mode**
- **RoHS Compliant**

\*Not backward compatible. Operational instability or inefficiency will occur if this device is applied on a PCIe 1.0 socket.

\*\*Varies from capacities. The performance and power consumption values addressed here are typical and may vary from platforms.

---

## Table of Contents

<b>1. General Description .....</b>	<b>3</b>
1.1 Error Correction/Detection.....	3
1.2 Flash Block Management .....	3
1.3 Global Wear Leveling .....	3
1.4 Power Failure Management .....	3
1.5 S.M.A.R.T. ....	4
<b>2. Pin Assignments.....</b>	<b>5</b>
<b>3. Product Specifications.....</b>	<b>8</b>
3.1 Capacity.....	8
3.2 Performance .....	8
3.3 Environmental Specifications .....	8
<b>4. Electrical Specifications .....</b>	<b>9</b>
<b>5. Mechanical specifications .....</b>	<b>10</b>
<b>6. Product Ordering Information.....</b>	<b>11</b>
6.1 Product Code Designations.....	11
6.2 Valid Combinations.....	12

---

## 1. General Description

Apacer's M.2 PT42 module-type SSD offers a breakthrough in non-volatile memory storage. Formed as a compact M.2 2242 form factor, PT42 can fit in various types of embedded platforms, such as workstation, thin computing devices and high-end heavy duty servers where spaces are concerned. Regarding data transfer rate, PT42 delivers ideal data read/write performance.

Apacer M.2 PT42 is designed in PCI-Express 2.0 pinout, and is compatible with 5.0 Gbps maximum transfer rate. Compatibility wise, this M.2 SSD is not only fully compliant with PCI Express Specification Rev.2.0 and Electromechanical Rev.2.0, but also supports NCQ commands and AHCI operational modes.

### 1.1 Error Correction/Detection

---

The ECC engine in this device can detect and correct up to 72 bits error in 1K bytes.

### 1.2 Flash Block Management

---

Bad blocks are blocks that include one or more invalid bits, and their reliability is not guaranteed. Blocks that are identified and marked as bad by the manufacturer are referred to as "Initial Bad Blocks". Bad blocks that are developed during the lifespan of the flash are named "Later Bad Blocks". Thus, this device implements an efficient bad block management algorithm to detect the factory-produced bad blocks and manages any bad blocks that appear with use. This practice further prevents data being stored into bad blocks and improves the data reliability.

### 1.3 Global Wear Leveling

---

Flash memory devices differ from Hard Disk Drives (HDDs) in terms of how blocks are utilized. For HDDs, when a change is made to stored data, like erase or update, the controller mechanism on HDDs will perform overwrites on blocks. Unlike HDDs, flash blocks cannot be overwritten and each P/E cycle wears down the lifespan of blocks gradually. Repeatedly program/erase cycles performed on the same memory cells will eventually cause some blocks to age faster than others. This would bring flash storages to their end of service term sooner. Global wear leveling is an important mechanism that levels out the wearing of all blocks so that the wearing-down of all blocks can be almost evenly distributed. This will increase the lifespan of SSDs.

### 1.4 Power Failure Management

---

Power Failure Management plays a crucial role when experiencing unstable power supply. Power disruption may occur when users are storing data into the SSD. In this urgent situation, the controller would run multiple write-to-flash cycles to store the metadata for later block rebuilding. This urgent operation requires about several milliseconds to get it done. At the next power up, the firmware will perform a status tracking to retrieve the mapping table and resume previously programmed NAND blocks to check if there is any incompleteness of transmission.

---

## **1.5 S.M.A.R.T.**

---

SMART, an acronym for Self-Monitoring, Analysis and Reporting Technology, is an open standard that allows a hard disk drive to automatically detect its health and report potential failures. When a failure is recorded by SMART, users can choose to replace the drive to prevent unexpected outage or data loss. Moreover, SMART can inform users of impending failures while there is still time to perform proactive actions, such as copy data to another device.

## 2. Pin Assignments

This connector does not support hot plug capability. There are a total of 75 pins. 12 pin locations are used for mechanical key locations; this allows such a module to plug into both Key B and Key M connectors.

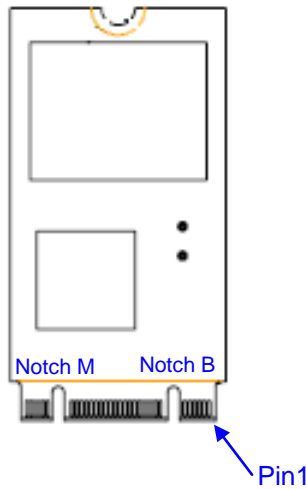

Pin	Type	Description
1	CONFIG_3	Ground (according to M.2 configurations for PCIe SSD definition)
2	3.3V	Supply Pin, 3.3V
3	GND	Ground
4	3.3V	Supply pin, 3.3V
5	No connect	No connect
6	Not available	No connect (used for other purposes)
7	Not available	No connect (used for other purposes)
8	Not available	No connect (used for other purposes)
9	No connect	No connect
10	DAS/DSS	Device Activity Signal/Disable Staggered Spin-up
11	No connect	No connect (used for other purposes)
12	(removed for key)	Mechanical notch B
13	(removed for key)	Mechanical notch B
14	(removed for key)	Mechanical notch B
15	(removed for key)	Mechanical notch B
16	(removed for key)	Mechanical notch B
17	(removed for key)	Mechanical notch B
18	(removed for key)	Mechanical notch B
19	(removed for key)	Mechanical notch B
20	Not available	No connect (used for other purposes)
21	CONFIG_0	Ground (according to M.2 configurations for PCIe SSD definition)

# PCI-Express Disk Module

## APPxxxG3FA-BTM



Pin	Type	Description
22	Not available	No connect (used for other purposes)
23	Not available	No connect (used for other purposes)
24	Not available	No connect (used for other purposes)
25	Not available	No connect (used for other purposes)
26	Not available	No connect (used for other purposes)
27	GND	Ground
28	Not available	No connect (used for other purposes)
29	PETn1	
30	Not available	No connect (used for other purposes)
31	PETp1	
32	Not available	No connect (used for other purposes)
33	GND	Ground
34	Not available	No connect (used for other purposes)
35	PERn1	
36	Not available	No connect (used for other purposes)
37	PERp1	
38	Not available	No connect (used for other purpose)
39	GND	Ground
40	Not available	No connect (used for other purposes)
41	PETn0	
42	Not available	No connect (used for other purposes)
43	PETp0	
44	Not available	No connect (used for other purposes)
45	GND	Ground
46	Not available	No connect (used for other purposes)
47	PERn0	
48	Not available	No connect (used for other purposes)
49	PERp0	
50	PERST#	
51	GND	Ground
52	Not Available	No connect (used for other purposes)
53	REFCLKN	
54	Not Available	No connect (used for other purposes)
55	REFCLKP	
56	Not Available	No connect (used for other purposes)
57	GND	Ground

**PCI-Express Disk Module**  
**APPxxxG3FA-BTM**



Pin	Type	Description
58	Not Available	No connect (used for other purposes)
59	(removed for key)	Mechanical notch B
60	(removed for key)	Mechanical notch B
61	(removed for key)	Mechanical notch B
62	(removed for key)	Mechanical notch B
63	(removed for key)	Mechanical notch B
64	(removed for key)	Mechanical notch B
65	(removed for key)	Mechanical notch B
66	(removed for key)	Mechanical notch B
67	Not available	No connect (used for other purposes)
68	Not available	No connect (used for other purposes)
69	CONFIG_1	No connect (according to M.2 configurations for PCIe SSD definition)
70	3.3V	Supply pin, 3.3V
71	GND	Ground
72	3.3V	Supply pin, 3.3V
73	GND	Ground
74	3.3V	Supply pin, 3.3V
75	CONFIG_2	Ground

## 3. Product Specifications

### 3.1 Capacity

Table 3-1 Capacity Specifications

Capacity	Total bytes*	Cylinders	Heads	Sectors	Max LBA
8 GB	8,012,390,400	15,525	16	63	15,649,200
16 GB	16,013,942,784	16,383	16	63	31,277,232
32 GB	32,017,047,552	16,383	16	63	62,533,296
64 GB	64,023,257,088	16,383	16	63	125,045,424

\*Display of total bytes varies from file systems.

\*\*Cylinders, heads or sectors are not applicable for these capacities. Only LBA addressing applies.

LBA count addressed in the table above indicates total user storage capacity and will remain the same throughout the lifespan of the device. However, the total usable capacity of M.2 PT42 is most likely to be less than the total physical capacity because a small portion of the capacity is reserved for device maintenance usages.

### 3.2 Performance

Performance of M.2 PT42 is listed in the following table.

Table 3-2 Performance

Performance \ Capacity	8 GB	16 GB	32 GB	64 GB
	<b>Sustained Read (MB/s)</b>	145	290	515
<b>Sustained Write (MB/s)</b>	44	85	155	180

Note: Results may differ from various flash configurations or host system settings.

### 3.3 Environmental Specifications

Environmental specifications of M.2 PT42 product family follow the MIL-STD-810F standard.

Table 3-3 Environmental Specifications

Environment		Specifications
Temperature	Operating	0°C to 80°C
	Storage	-40°C to 85°C
Humidity		5% to 95% RH (Non-condensing)
Vibration (Non-Operating)		Sine wave : 10~2000Hz, 15G (X, Y, Z axes)
Shock (Non-Operating)		Half sine wave, 1500 G (X, Y, Z ; All 6 axes)

## 4. Electrical Specifications

**Caution: Absolute Maximum Stress Ratings** – Applied conditions greater than those listed under “Absolute Maximum Stress Ratings” may cause permanent damage to the device. This is a stress rating only and functional operation of the device at these conditions or conditions greater than those defined in the operational sections of this data sheet is not implied. Exposure to absolute maximum stress rating conditions may affect device reliability.

**Table 4-1** Absolute Maximum Stress Ratings

Parameter	Min.	Typical	Max.	Units
Power supply	3.13	3.3	3.46	V
Operating case temperature	0		80	°C
Storage temperature	-40		85	°C

**Table 4-2** Power Consumption

State \ Capacity	8 GB	16 GB	32 GB	64 GB
<b>Active (mA)</b>	760	850	960	1025
<b>Idle (mA)</b>	530	530	530	530

Note: Results may differ from various flash configurations and platforms.

## 5. Mechanical specifications

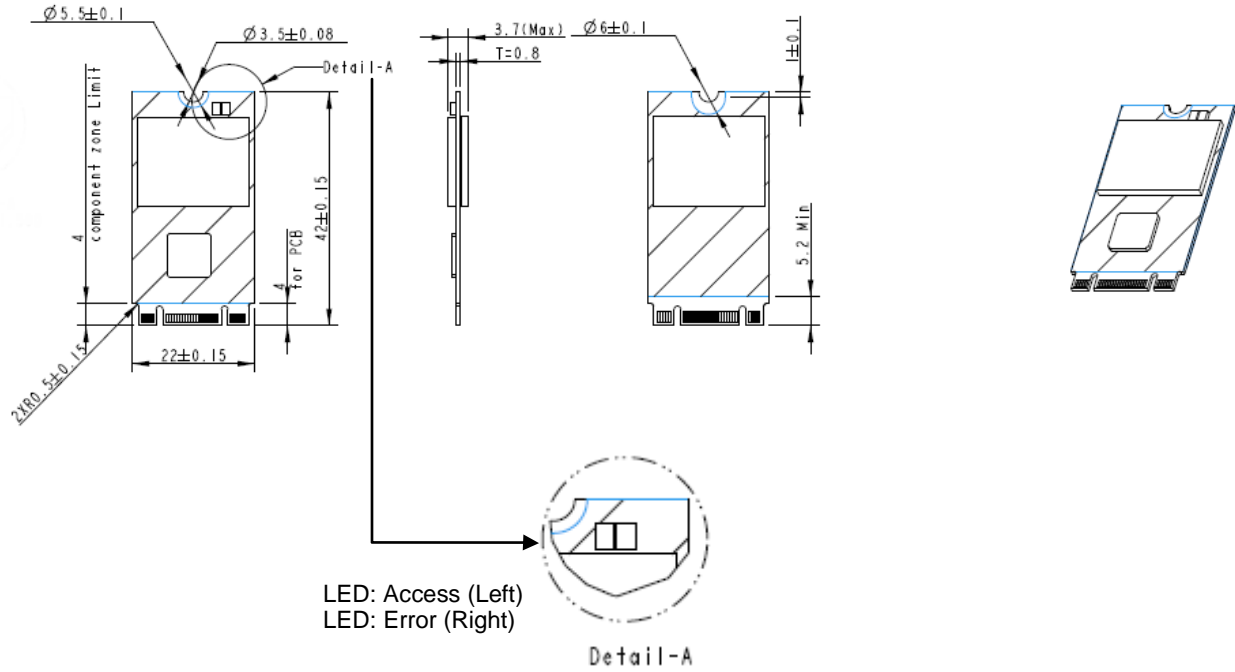

Unit: mm

Tolerance:  $\pm 0.25$

## 6. Product Ordering Information

### 6.1 Product Code Designations

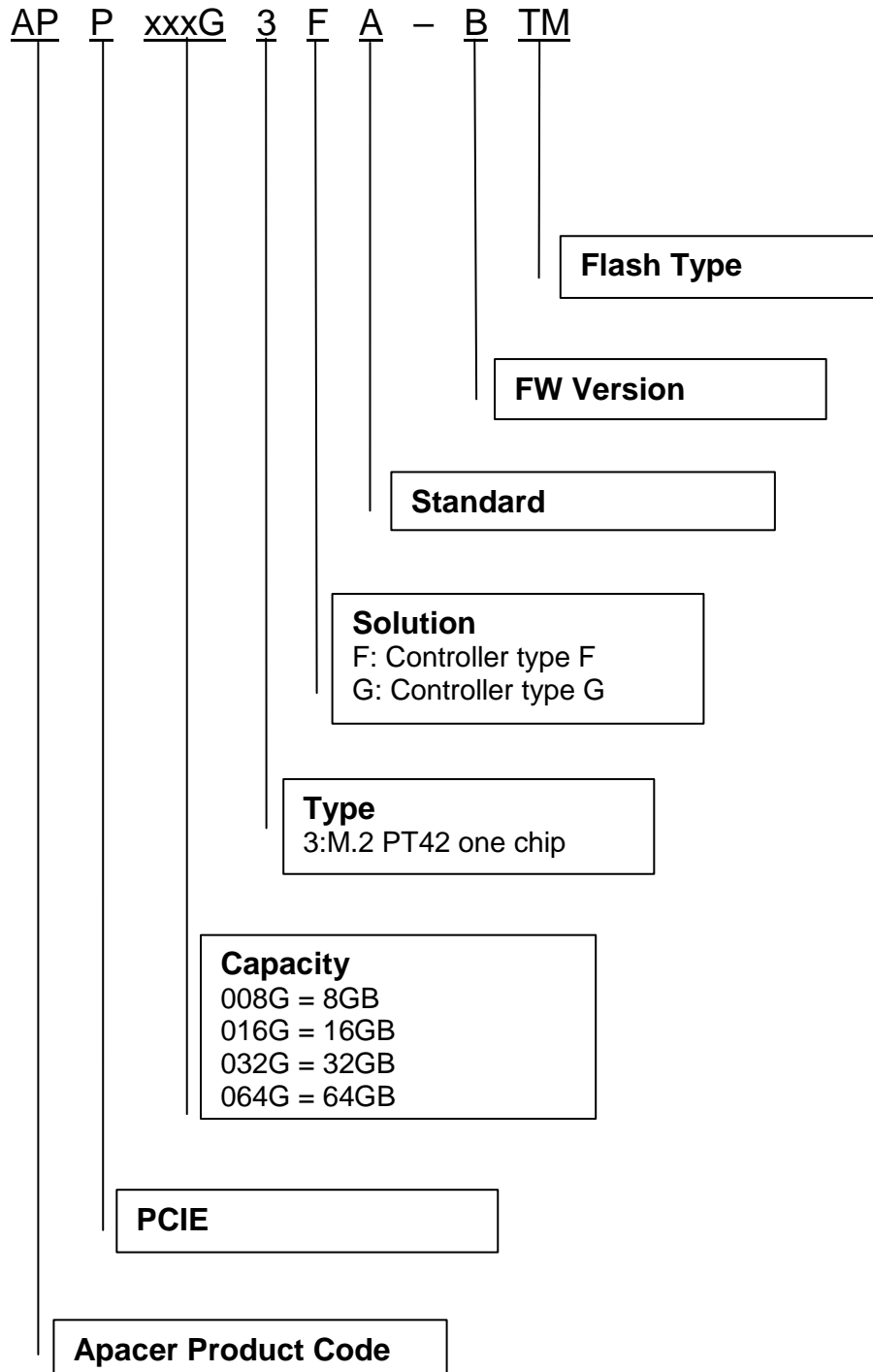

PCI-Express Disk Module  
APPxxxG3FA-BTM



---

## 6.2 Valid Combinations

---

Capacity	M/N
8GB	APP008G3FA-BTM
16GB	APP016G3FA-BTM
32GB	APP032G3FA-BTM
64GB	APP064G3FA-BTM

**Note:** Valid combinations are those products in mass production or will be in mass production. Consult your Apacer sales representative to confirm availability of valid combinations and to determine availability of new combinations.

---

## Revision History

Revision	Date	Description	Remark
1.0	10/29/2014	Official release	
1.1	12/17/2014	Updated product ordering information	
1.2	01/05/2015	Updated mechanical specifications	
1.3	04/13/2015	Revised product code designations	
1.4	3/22/2017	- Added "Supports UEFI Mode" on Features page - Updated product ordering information	

---

## Global Presence

<b>Taiwan (Headquarters)</b>	<b>Apacer Technology Inc.</b> 1F., No.32, Zhongcheng Rd., Tucheng Dist., New Taipei City 236, Taiwan R.O.C. Tel: 886-2-2267-8000 Fax: 886-2-2267-2261 <a href="mailto:amtsales@apacer.com">amtsales@apacer.com</a>
<b>U.S.A.</b>	<b>Apacer Memory America, Inc.</b> 46732 Lakeview Blvd., Fremont, CA 94538 Tel: 1-408-518-8699 Fax: 1-510-249-9551 <a href="mailto:sa@apacerus.com">sa@apacerus.com</a>
<b>Japan</b>	<b>Apacer Technology Corp.</b> 5F, Matsura Bldg., Shiba, Minato-Ku Tokyo, 105-0014, Japan Tel: 81-3-5419-2668 Fax: 81-3-5419-0018 <a href="mailto:jpservices@apacer.com">jpservices@apacer.com</a>
<b>Europe</b>	<b>Apacer Technology B.V.</b> Science Park Eindhoven 5051 5692 EB Son, The Netherlands Tel: 31-40-267-0000 Fax: 31-40-290-0686 <a href="mailto:sales@apacer.nl">sales@apacer.nl</a>
<b>China</b>	<b>Apacer Electronic (Shanghai) Co., Ltd</b> Room D, 22/FL, No.2, Lane 600, JieyunPlaza, Tianshan RD, Shanghai, 200051, China Tel: 86-21-6228-9939 Fax: 86-21-6228-9936 <a href="mailto:sales@apacer.com.cn">sales@apacer.com.cn</a>
<b>India</b>	<b>Apacer Technologies Pvt Ltd,</b> Unit No.201, "Brigade Corner", 7 <sup>th</sup> Block Jayanagar, Yediyur Circle, Bangalore – 560082, India Tel: 91-80-4152-9061 Fax: 91-80-4170-0215 <a href="mailto:sales_india@apacer.com">sales_india@apacer.com</a>