

RoHS Compliant

PCI Express Flash Drive

Industrial PH250-CFX BiCS5 Product Specifications



December 18, 2023

Version 1.0



Apacer Technology Inc.

1F, No.32, Zhongcheng Rd., Tucheng Dist., New Taipei City, Taiwan, R.O.C

Tel: +886-2-2267-8000 Fax: +886-2-2267-2261

www.apacer.com

Specifications Overview:

- **PCIe Interface**
 - Compliant with PCI Express 4.0
 - Compliant with NVMe 2.0
 - Compatible with PCIe Gen4 x2 interface
- **Capacity**
 - 160, 320 GB
- **Performance¹**
 - Interface burst read/write: 4 GB/sec
 - Sequential read: up to 3,740 MB/sec
 - Sequential write: up to 2,770 MB/sec
 - Random read (4K): up to 570,000 IOPS
 - Random write (4K): up to 573,000 IOPS
- **Flash Management**
 - Low-Density Parity-Check (LDPC) Code
 - Global Wear Leveling
 - Flash bad-block management
 - Flash Translation Layer: Page Mapping
 - DataDefender™
 - S.M.A.R.T.
 - TRIM
 - SLC-liteX (P/E cycle: 100K)
 - SMART Read Refresh™
- **NVMe Features²**
 - Supports HMB (Host Memory Buffer)
- **NAND Flash Type: 3D TLC (BiCS5)**
- **MTBF: >3,000,000 hours**
- **Endurance (in drive writes per day: DWPD)**
 - 160 GB: 42.05 DWPD
 - 320 GB: 41.16 DWPD
- **Temperature Range**
 - Operating:
 - Standard: 0°C to 70°C
 - Wide: -40°C to 85°C
 - Storage: -55°C to 100°C
- **Supply Voltage**
 - 3.3V ± 5%
- **Power Consumption¹**
 - Active mode (Max.): 1,135 mA
 - Idle mode: 155 mA
- **Power Management**
 - Supports APST
 - Supports ASPM L1.2
- **Physical Characteristics**
 - Form factor: CFexpress 2.0 Type B
 - Dimensions: 29.6 x 38.5 x 3.8, unit: mm
 - Net weight: 6.43g ± 5%
- **Security**
 - AES 256-bit hardware encryption
- **Reliability**
 - Thermal Sensor
 - Thermal Throttling
 - End-to-End Data Protection
- **RoHS Compliant**

Notes:

1. Varies from capacities. The values for performances and power consumptions presented are typical and may vary depending on flash configurations or platform settings.
2. Windows 10 (version 1703) onwards supports the HMB (Host Memory Buffer) function.

Table of Contents

1. General Description	4
2. Functional Block	4
3. Pin Assignments.....	5
4. Product Specifications.....	7
4.1 Capacity.....	7
4.2 Performance	7
4.3 Environmental Specifications	7
4.4 Mean Time Between Failures (MTBF)	8
4.5 Certification and Compliance.....	8
4.6 Endurance	8
5. Flash Management	9
5.1 Error Correction/Detection.....	9
5.2 Bad Block Management	9
5.3 Global Wear Leveling	9
5.4 Flash Translation Layer – Page Mapping.....	9
5.5 DataDefender™	10
5.6 TRIM.....	10
5.7 SLC-liteX.....	10
5.8 SMART Read Refresh™	10
6. NVMe Support Features	11
6.1 Host Memory Buffer.....	11
7. Security and Reliability Features	12
7.1 Advanced Encryption Standard	12
7.2 Thermal Sensor	12
7.3 Thermal Throttling	12
7.4 End-to-End Data Protection.....	12
8. Software Interface	13
8.1 Command Set.....	13
8.2 S.M.A.R.T.	14
9. Electrical Specifications.....	16

9.1 Operating Voltage.....	16
9.2 Power Consumption	16
10. Mechanical Specifications	17
11. Product Ordering Information.....	18
11.1 Product Code Designations.....	18
11.2 Valid Combinations.....	19

1. General Description

Apacer Industrial CFexpress PH250-CFX, utilizing 3D NAND for higher capacity up to 320GB and providing more power efficiency than 2D NAND, is the next generation Solid State Drive (SSD) with compact and high-speed storage to support larger, faster hosts deployed in a wide range of applications that require outstanding performance.

PH250-CFX provides full compliance with the latest PCIe Gen4 x2 and NVMe Express interface specifications which allows the SSD to not only operate in power management modes and greatly save on power consumption, but also deliver exceptionally low latency and high performance, up to 3,740MB/s read and 2,770MB/s write. This new standard is designed for a variety of applications ranging from industrial, imaging, computing to enterprise markets.

PH250-CFX is built with a powerful PCIe controller that supports on-the-module ECC as well as efficient wear leveling scheme, and implemented with LDPC (Low Density Parity Check) ECC engine and SLC-liteX technology to extend SSD endurance with P/E cycles up to 100,000 times and increase data reliability. Furthermore, PH250-CFX is equipped with a built-in thermal sensor to monitor the temperature of the SSD via S.M.A.R.T commands and configured with thermal throttling to dynamically adjust frequency scaling to enhance data reliability and provide sustained performance while overheating. For highly-intensive applications, End-to-End Data Protection ensures that data integrity can be assured at multiple points in the path to enable reliable delivery of data transfers.

Security-wise, Advanced Encryption Standard (AES) ensures data security and provides users with peace of mind knowing their data is safeguarded against unauthorized use at all times. PH250-CFX also adopts the latest page mapping file translation layer and comes with various implementations including flash block management, DataDefender, power saving modes, TRIM, and SMART Read Refresh.

With exceptional performance, trustable reliability, and enhanced data protection, PH250-CFX is definitely the ideal storage or cache solution for a variety of applications ranging from industrial, imaging, computing to enterprise markets.

2. Functional Block

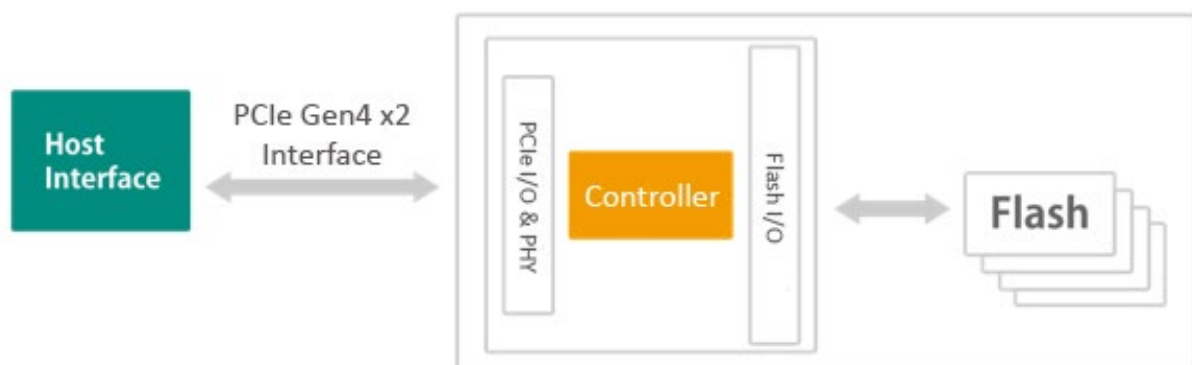

Note: The actual number of NAND flash used on Apacer PH250-CFX varies from capacities. The illustration is for reference only.

Figure 2-1 Functional Block Diagram

3. Pin Assignments

Table 3-1 lists the pin assignment of the media. The I/O column indicates the signal direction viewed from the media: “I” indicates the signal input to the media and “O” indicates the signal output from the media. In the Connection column, “R” indicates the signal is required, “Opt” indicates the signal is optional, and “NC” indicates the signal shall not be connected.

Table 3-1 Pin Assignments and Description

Pin No.	Signal	I/O	Media	Host	Notes
21	GND		R	R	
20	PETp0	I	R	R	
19	PETn0	I	R	R	
18	GND		R	R	
17	PERp0	O	R	R	
16	PERn0	O	R	R	
15	GND		R	R	
14	REFCLK+	I	R	R	
13	REFCLK-	I	R	R	
12	INS#	O	R	R	1
11	CLKREQ#	O	R	Opt	2
10	+3.3V		R	R	
9	PERST#	I	R	R	
8	Reserved		NC	NC	3
7	Reserved		NC	NC	4
6	PETp1	I	Opt	Opt	
5	PETn1	I	Opt	Opt	
4	GND		R	Opt	5
3	PERp1	O	Opt	Opt	
2	PERn1	O	Opt	Opt	
1	GND		R	R	

Notes:

1. A host pull-up resistor in the range of 100kΩ-200kΩ is required on this pin.
2. A host pull-up resistor (≥5kΩ) is required on this pin.
3. Reserved by Apacer, please do not connect to a host.
4. Reserved by Apacer, please do not connect to a host.
5. If the PCI Express Transmitter differential pair Lane 1 and Receiver differential pair Lane 1 are implemented, this pin shall be connected to ground.

Table 3-2 Signal and Pin Assignments

Category	Signal Name	Description
PCI Express	PETp0	PCI Express two Lanes. 2 transmitter differential pairs and 2 receiver differential pairs.
	PETn0	
	PERp0	
	PERn0	
	PETp1	
	PETn1	
	PERp1	
	PERn1	
Auxiliary	REFCLK+	PCI Express differential (and spread-spectrum) reference clock.
	REFCLK-	
	PERST#	PCI Express functional reset.
	INS#	This signal is used for media detection and power control.
	CLKREQ#	This signal is used to indicate when REFCLK is needed for the PCI Express interface.
Power Source	+3.3V	3.3V power
Ground	GND	Round

4. Product Specifications

4.1 Capacity

Capacity specifications of PH250-CFX are available as shown in Table 4-1.

Table 4-1 Capacity Specifications

Capacity	Total bytes	Total LBA
160 GB	160,041,885,696	312,581,808
320 GB	320,072,933,376	625,142,448

Notes:

- Display of total bytes varies from operating systems.
- 1 GB = 1,000,000,000 bytes; 1 sector = 512 bytes.
- LBA count addressed in the table above indicates total user storage capacity and will remain the same throughout the lifespan of the device. However, the total usable capacity of the SSD is most likely to be less than the total physical capacity because a small portion of the capacity is reserved for device maintenance usages.

4.2 Performance

Performance of PH250-CFX is listed below in Table 4-2.

Table 4-2 Performance Specifications

Performance	Capacity	160 GB	320 GB
	Sequential Read (MB/s)		3,715
Sequential Write (MB/s)		2,110	2,770
4K Random Read (IOPS)		241,000	570,000
4K Random Write (IOPS)		425,000	573,000

Notes:

- Measured with OS version: Win10 (64bit), version 1803 with HMB (Host Memory Buffer), performance may differ from various flash configurations or host system settings.
- Sequential read/write is based on CrystalDiskMark 8.0.4 with file size 1,000MB.
- Random read/write is measured using IOMeter with Queue Depth 128.

4.3 Environmental Specifications

Environmental specifications of PH250-CFX are shown in Table 4-3.

Table 4-3 Environmental Specifications

Parameter	Type	Specifications
Temperature	Operating	0°C to 70°C (Standard); -40°C to 85°C (Wide)
	Non-operating	-55°C to 100°C
Vibration	Operating	7.69 GRMS, 20~2000 Hz/random (compliant with MIL-STD-810G)
	Non-operating	4.02 GRMS, 15~2000 Hz/random (compliant with MIL-STD-810G)
Shock	Operating	Acceleration, 50(G)/11(ms)/half sine (compliant with MIL-STD-202G)
	Non-operating	Acceleration, 1500(G)/0.5(ms)/half sine (compliant with MIL-STD-883K)

Note: This Environmental Specification table indicates the conditions for testing the device. Real world usages may affect the results.

4.4 Mean Time Between Failures (MTBF)

Mean Time Between Failures (MTBF) is predicted based on reliability data for the individual components in PH250-CFX. The prediction result for PH250-CFX is more than 3,000,000 hours.

Note: The MTBF is predicated and calculated based on “Telcordia Technologies Special Report, SR-332, Issue 3” method.

4.5 Certification and Compliance

PH250-CFX complies with the following standards:

- CE
- UKCA
- FCC
- RoHS
- MIL-STD-810G
- UL

4.6 Endurance

The endurance of a storage device is predicted by Drive Writes Per Day based on several factors related to usage, such as the amount of data written into the drive, block management conditions, and daily workload for the drive. Thus, key factors, such as Write Amplifications and the number of P/E cycles, can influence the lifespan of the drive.

Table 4-4 Endurance Specifications

Capacity	Drive Writes Per Day
160 GB	42.05
320 GB	41.16

Notes:

- This estimation complies with JEDEC JESD-219, enterprise endurance workload of random data with payload size distribution.
- Flash vendor guaranteed 3D SLC-liteX P/E cycle: 100K
- WAF may vary from capacity, flash configurations and writing behavior on each platform.
- 1 Terabyte = 1,024GB
- DWPD (Drive Writes Per Day) is calculated based on the number of times that user overwrites the entire capacity of an SSD per day of its lifetime during the warranty period. (3D SLC-liteX warranty: 5 years)

5. Flash Management

5.1 Error Correction/Detection

PH250-CFX implements a hardware ECC scheme, based on the Low Density Parity Check (LDPC). LDPC is a class of linear block error correcting code which has apparent coding gain over BCH code because LDPC code includes both hard decoding and soft decoding algorithms. With the error rate decreasing, LDPC can extend SSD endurance and increase data reliability while reading raw data inside a flash chip.

5.2 Bad Block Management

Current production technology is unable to guarantee total reliability of NAND flash memory array. When a flash memory device leaves factory, it comes with a minimal number of initial bad blocks during production or out-of-factory as there is no currently known technology that produce flash chips free of bad blocks. In addition, bad blocks may develop during program/erase cycles. Since bad blocks are inevitable, the solution is to keep them in control. Apacer flash devices are programmed with ECC, page mapping technique and S.M.A.R.T to reduce invalidity or error. Once bad blocks are detected, data in those blocks will be transferred to free blocks and error will be corrected by designated algorithms.

5.3 Global Wear Leveling

Flash memory devices differ from Hard Disk Drives (HDDs) in terms of how blocks are utilized. For HDDs, when a change is made to stored data, like erase or update, the controller mechanism on HDDs will perform overwrites on blocks. Unlike HDDs, flash blocks cannot be overwritten and each P/E cycle wears down the lifespan of blocks gradually. Repeatedly program/erase cycles performed on the same memory cells will eventually cause some blocks to age faster than others. This would bring flash storages to their end of service term sooner. Global wear leveling is an important mechanism that levels out the wearing of all blocks so that the wearing-down of all blocks can be almost evenly distributed. This will increase the lifespan of SSDs.

5.4 Flash Translation Layer – Page Mapping

Page mapping is an advanced flash management technology whose essence lies in the ability to gather data, distribute the data into flash pages automatically, and then schedule the data to be evenly written. Page-level mapping uses one page as the unit of mapping. The most important characteristic is that each logical page can be mapped to any physical page on the flash memory device. This mapping algorithm allows different sizes of data to be written to a block as if the data is written to a data pool and it does not need to take extra operations to process a write command. Thus, page mapping is adopted to increase random access speed and improve SSD lifespan, reduce block erase frequency, and achieve optimized performance and lifespan.

5.5 DataDefender™

Apacer's DataDefender is an advanced technology of power failure management which combines both firmware and hardware mechanisms to ensure data integrity. When power disruption occurs, the low voltage detector will be triggered. When this happens, the SSD's protection mechanism is activated and cuts off data transmission from the host. Once the power supply is resumed, the firmware protection mechanism will ensure the integrity of the firmware as well as the data already written into the NAND flash media.

5.6 TRIM

TRIM is a feature which helps improve the read/write performance and speed of solid-state drives (SSD). Unlike hard disk drives (HDD), SSDs are not able to overwrite existing data, so the available space gradually becomes smaller with each use. With the TRIM command, the operating system can inform the SSD which blocks of data are no longer in use and can be removed permanently. Thus, the SSD will perform the erase action, which prevents unused data from occupying blocks all the time.

5.7 SLC-liteX

Apacer's 3D NAND SLC-liteX technology breaks through the limitations of existing technology and provides up to 100,000 P/E cycles, which is over 33 times more than MLC or industrial 3D TLC. Powered by carefully selected NAND components, the firmware structure is specifically optimized to enhance NAND flash stability during daily operations, and the error handling algorithm is significantly improved to avoid any unexpected ECC errors. The longest lifespans are therefore available at reasonable cost.

5.8 SMART Read Refresh™

Apacer's SMART Read Refresh plays a proactive role in avoiding read disturb errors from occurring to ensure health status of all blocks of NAND flash. Developed for read-intensive applications in particular, SMART Read Refresh is employed to make sure that during read operations, when the read operation threshold is reached, the data is refreshed by re-writing it to a different block for subsequent use.

6. NVMe Support Features

6.1 Host Memory Buffer

Host Memory Buffer (HMB) allows HOST to allocate system memory for SSD's exclusive use in order to provide better performance and endurance, especially for DRAMless solutions.

7. Security and Reliability Features

7.1 Advanced Encryption Standard

Advanced Encryption Standard (AES) is a specification for the encryption of electronic data. AES has been adopted by the U.S. government since 2001 to protect classified information and is now widely implemented in embedded computing applications. The AES algorithm used in software and hardware is symmetric so that encrypting/decrypting requires the same encryption key. Without the key, the encrypted data is inaccessible to ensure information security.

Notably in flash memory applications, AES 256-bit hardware encryption is the mainstream to protect sensitive or confidential data. The hardware encryption provides better performance, reliability, and security than software encryption. It uses a dedicated processor, which is built inside the controller, to process the encryption and decryption. This enormously shortens the processing time and makes it efficient.

7.2 Thermal Sensor

Apacer Thermal Sensor is a digital temperature sensor with serial interface. By using designated pins for transmission, storage device owners are able to read temperature data.

7.3 Thermal Throttling

Thermal throttling can monitor the temperature of the SSD equipped with a built-in thermal sensor. This method can ensure the temperature of the device stays within temperature limits by drive throttling, i.e. reducing the speed of the drive when the device temperature reaches the threshold level, so as to prevent overheating, guarantee data reliability, and prolong product lifespan. When the temperature exceeds the maximum threshold level, thermal throttling will be triggered to reduce performance step by step to prevent hardware components from being damaged. Performance is only permitted to drop to the extent necessary for recovering a stable temperature to cool down the device's temperature. Once the temperature decreases to the minimum threshold value, transfer speeds will rise back to its optimum performance level.

7.4 End-to-End Data Protection

End-to-End Data Protection is a feature implemented in Apacer SSD products that extends error control to cover the entire path from the host computer to the drive and back, and that ensures data integrity at multiple points in the path to enable reliable delivery of data transfers. Unlike ECC which does not exhibit the ability to determine the occurrence of errors throughout the process of data transmission, End-to-End Data Protection allows SSD controller to identify an error created anywhere in the path and report the error to the host computer before it is written to the drive. This error-checking and error-reporting mechanism therefore guarantees the trustworthiness and reliability of the SSD.

8. Software Interface

8.1 Command Set

Table 8-1 summarizes the commands supported by PH250-CFX.

Table 8-1 Admin Commands

Opcode	Command Description
00h	Delete I/O Submission Queue
01h	Create I/O Submission Queue
02h	Get Log Page
04h	Delete I/O Completion Queue
05h	Create I/O Completion Queue
06h	Identify
08h	Abort
09h	Set Features
0Ah	Get Features
0Ch	Asynchronous Event Request
10h	Firmware Commit
11h	Firmware Image Download
14h	Device Self-test

Table 8-2 Admin Commands – NVM Command Set Specific

Opcode	Command Description
80h	Format NVM
84h	Sanitize

Table 8-3 NVM Commands

Opcode	Command Description
00h	Flush
01h	Write
02h	Read
04h	Write Uncorrectable
05h	Compare
08h	Write Zeroes
09h	Dataset Management

8.2 S.M.A.R.T.

SMART, an acronym for Self-Monitoring, Analysis and Reporting Technology, is an open standard that allows a hard disk drive to automatically detect its health and report potential failures. When a failure is recorded by SMART, users can choose to replace the drive to prevent unexpected outage or data loss. Moreover, SMART can inform users of impending failures while there is still time to perform proactive actions, such as copy data to another device.

Table 8-4 SMART (02h)

Byte	Length	Description
0	1	Critical Warning
1-2	2	Composite Temperature
3	1	Available Spare
4	1	Available Spare Threshold
5	1	Percentage Used (Average Erase Count / P/E Cycle Count)
6-31	26	Reserved
32-47	16	Data Units Read
48-63	16	Data Units Written
64-79	16	Host Read Commands
80-95	16	Host Write Commands
96-111	16	Controller Busy Time
112-127	16	Power Cycles
128-143	16	Power On Hours
144-159	16	Unsafe Shutdowns
160-175	16	Media and Data Integrity Errors
176-191	16	Number of Error Information Log Entries
192-195	4	Warning Composite Temperature Time
196-199	4	Critical Composite Temperature Time
200-201	2	Temperature Sensor 1: Controller Temperature
202-203	2	Temperature Sensor 2: PCB Temperature
204-205	2	Temperature Sensor 3: NAND Flash Temperature
206-207	2	Temperature Sensor 4
208-209	2	Temperature Sensor 5
210-211	2	Temperature Sensor 6
212-213	2	Temperature Sensor 7
214-215	2	Temperature Sensor 8
216-511	296	Reserved

Note: Temperature display of the Temperature Sensor from 1 to 8 (corresponding bytes from 200 to 215) is not supported if the return value is 0h.

Table 8-5 SMART (C0h)

Byte	Length	Description
0-255	256	Reserved
256-257	2	SSD Protect Mode
258-261	4	Host Read UNC Count
262-265	4	Reserved
266-269	4	CRC Error Count
270-273	4	Total Early Bad Block Count
274-277	4	Total Later Bad Block Count
278-281	4	Max Erase Count
282-285	4	Average Erase Count
286-289	4	Program Fail Count
290-293	4	Erase Fail Count
294-301	8	Flash Write Sector
302-305	4	Total Spare Block
306-309	4	Current Spare Block
310-313	4	Read Retry Count
314-511	210	Reserved

9. Electrical Specifications

9.1 Operating Voltage

Table 9-1 lists the supply voltage for PH250-CFX.

Table 9-1 Operating Range

Item	Range
Supply Voltage	3.3V ± 5%

9.2 Power Consumption

Table 9-2 lists the power consumption for PH250-CFX.

Table 9-2 Power Consumption

Mode	Capacity	Unit	160 GB	320 GB
Active (Max.)		mA	1,135	1,110
Idle			155	150

Notes:

- All values are typical and may vary depending on flash configurations or host system settings.
- Power consumption is measured using CrystalDiskMark 8.0.4 with file size 1,000MB.

10. Mechanical Specifications

Table 10-1 Physical Information

Parameter	Unit	160 GB	320 GB
Length	mm	38.50 ± 0.20	
Width		29.60 ± 0.10	
Height		3.80 ± 0.15	
Weight	g ± 5%	6.3	6.43

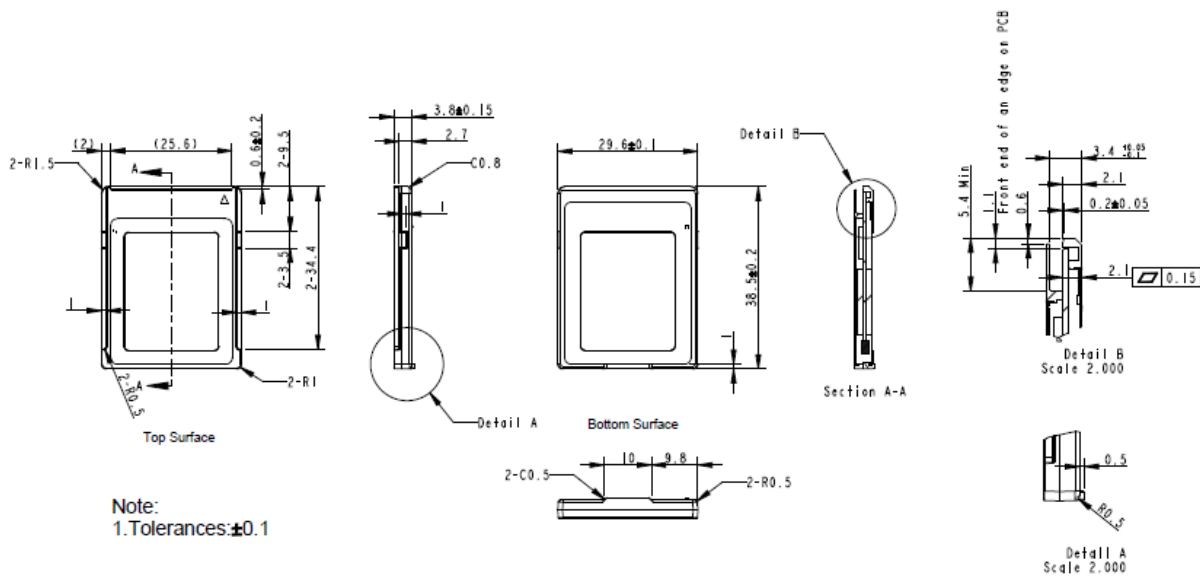

Figure 10-1 Physical Dimensions

11. Product Ordering Information

11.1 Product Code Designations

Apacer's PH250-CFX SSD is available in different configurations and densities. See the chart below for a comprehensive list of options for the PH250-CFX series devices.

Code	1	2	3	4	5	6	7	8	9	10	11	12	13	14	15	16
	B	D	2	.	2	5	9	X	H	A	.	0	0	1	1	6

Code 1-3 (Product Line & Form Factor)	PCIe + CFexpress
Code 5-6 (Model/Solution)	PH250
Code 7-8 (Product Capacity)	9K: 160GB 9L: 320GB
Code 9 (Flash Type & Product Temp)	Y: 3D TLC SLC-liteX Standard Temperature Z: 3D TLC SLC-liteX Wide Temperature
Code 10 (Product Spec)	CFexpress 2.0 Type B
Code 12-14 (Version Number)	Random numbers generated by system
Code 15-16 (Firmware Version)	SLC-liteX Thermal Sensor

11.2 Valid Combinations

The following table lists the available models of the PH250-CFX series which are in mass production or will be in mass production. Consult your Apacer sales representative to confirm availability of valid combinations and to determine availability of new combinations.

Capacity	Standard Temperature	Wide Temperature
160GB	BD2.259KYA.00116	BD2.259KZA.00116
320GB	BD2.259LYA.00116	BD2.259LZA.00116

Revision History

Revision	Description	Date
1.0	Initial release	12/18/2023

Global Presence

Taiwan (Headquarters)

Apacer Technology Inc.

1F., No.32, Zhongcheng Rd., Tucheng Dist.,
New Taipei City 236, Taiwan R.O.C.
Tel: 886-2-2267-8000
Fax: 886-2-2267-2261
amtsales@apacer.com

U.S.A.

Apacer Memory America, Inc.

46732 Lakeview Blvd., Fremont, CA 94538
Tel: 1-408-518-8699
Fax: 1-510-249-9551
sa@apacerus.com

Japan

Apacer Technology Corp.

6F, Daiyontamachi Bldg., 2-17-12, Shibaura, Minato-Ku,
Tokyo, 108-0023, Japan
Tel: 81-3-5419-2668
Fax: 81-3-5419-0018
jpservices@apacer.com

Europe

Apacer Technology B.V.

Science Park Eindhoven 5051 5692 EB Son,
The Netherlands
Tel: 31-40-267-0000
Fax: 31-40-290-0686
sales@apacer.nl

China

Apacer Electronic (Shanghai) Co., Ltd

Room D, 22/FL, No.2, Lane 600, JieyunPlaza,
Tianshan RD, Shanghai, 200051, China
Tel: 86-21-6228-9939
Fax: 86-21-6228-9936
sales@apacer.com.cn

India

Apacer Technologies Pvt Ltd,

1874, South End C Cross, 9th Block Jayanagar,
Bangalore-560069, India
Tel: 91-80-4152-9061/62
Fax: 91-80-4170-0215
sales_india@apacer.com