

***Halogen Free***

***Value Added ATA Disk Module III***

***Specifications for Standard ADM (40P/180D) Middle Profile***

**October 8<sup>th</sup>, 2013**

*Version 1.2*



***Apacer Technology Inc.***

1F, No.32, Zhongcheng Rd., Tucheng Dist., New Taipei City, Taiwan, R.O.C

Tel: +886-2-2267-8000 Fax: +886-2-2267-2261

[www.apacer.com](http://www.apacer.com)

## Features:

- **Standard ATA/IDE Bus Interface**
  - 512 bytes per sector
  - ATA command set compatible
  - ATA operating mode supports up to:
    - PIO Mode-4
    - Multiword DMA Mode-2
    - Ultra DMA Mode-4
- **Connector type**
  - 40-pin female connector
- **Power consumption (typical)\***
  - Supply voltage: 3.3V & 5V
  - Active mode: 85mA/95mA (3.3V/5V)
  - Sleep mode: 500µA /600µA (3.3V/5V)
- **Performance\***
  - Sustained read: Up to 21 MB/sec
  - Sustained write: Up to 15 MB/sec
- **Capacity**
  - 128, 256, 512 MB
  - 1, 2, 4, 8, 16 GB
- **NAND flash type: SLC**
- **Endurance (TBW: Terabytes Written)**
  - 128 MB: 3.5 TBW
  - 256 MB: 6.9 TBW
  - 512 MB: 14.0 TBW
  - 1 GB: 27.4 TBW
  - 2 GB: 45.5 TBW
  - 4 GB: 54.7 TBW
  - 8 GB: 80.6 TBW
- **Temperature ranges**
  - Operating:
    - Standard: 0 °C to 70 °C
    - Extended: -40 °C to 85 °C
  - Storage: -40 °C to 100 °C
  -
- **Flash management**
  - Advanced wear-leveling algorithms
  - S.M.A.R.T. technology
  - Built-in hardware ECC
  - Flash block management
  - Power failure management
  - ATA Security Erase
- **Form factor**
  - ATA Disk Module (40-pin/180-degree )
  - Dimensions w/housing:  
58.90x28.34x10.2, unit: mm
  - Dimensions w/o housing:  
51.40x25.30x7.00, unit: mm
- **Shock & Vibration\*\***
  - Shock: 1,500 G
  - Vibration: 15 G
- **Halogen Free**
- **Pin20 blocked**
- **Hardware switch for Master/Slave setting and/or Write Protect (optional)**

\*Varies from capacities. The values addressed for Performance and Power consumptions are typical and may vary depending on settings and platforms.

\*\*Non-operating

---

## Table of Contents

<b>1. GENERAL DESCRIPTION .....</b>	<b>3</b>
<b>2. FUNCTIONAL BLOCK .....</b>	<b>3</b>
<b>3. PIN ASSIGNMENTS .....</b>	<b>4</b>
<b>4. PRODUCT SPECIFICATIONS.....</b>	<b>5</b>
4.1 CAPACITY.....	5
4.2 PERFORMANCE .....	5
4.3 ENVIRONMENTAL SPECIFICATION.....	6
4.4 ENDURANCE .....	6
<b>5. FLASH MANAGEMENT .....</b>	<b>7</b>
5.1. ADVANCED WEAR-LEVELING ALGORITHMS .....	7
5.2 S.M.A.R.T. TECHNOLOGY .....	7
5.3 BUILT-IN HARDWARE ECC .....	7
5.4 FLASH BLOCK MANAGEMENT .....	7
5.5 POWER FAILURE MANAGEMENT.....	7
5.6 ATA SECURITY ERASE.....	8
<b>6. SOFTWARE INTERFACE .....</b>	<b>9</b>
6.1 COMMAND SET.....	9
<b>7. ELECTRICAL SPECIFICATION .....</b>	<b>11</b>
<b>8. PHYSICAL CHARACTERISTICS.....</b>	<b>12</b>
8.1 DIMENSION.....	12
8.1.1 40-pin/180-Degree Middle Profile Without Housing .....	12
8.1.2 40-pin/180-degree Middle Profile With Housing.....	13
<b>9. PRODUCT ORDERING INFORMATION.....</b>	<b>15</b>
9.1 PRODUCT CODE DESIGNATIONS .....	15
9.2 VALID COMBINATIONS .....	16

## 1. General Description

Apacer's ATA-Disk Module (ADM) is a high-performance, embedded flash drive designed to replace the conventional PATA (ATA/IDE) hard disk drive. The ADMs can be plugged into a standard PATA connector commonly found in desktops, IT-STB, industrial PCs and thin client systems. Apacer's ADM SSD has a built-in microcontroller with file management firmware that communicates with the ATA standard interfaces. No additional or proprietary host software is required.

The ADM is well suited for embedded flash storage applications by offering new and expanded functionalities as well as more cost-effective designs, better performance and increased reliability. The ATA DOM is designed to work at either 5 or 3.3 Volts, supports the standard PATA (ATA/IDE) protocol for up to PIO Mode-4, Multiword DMA Mode-2 and Ultra DMA Mode-4 interfaces, and uses the standard ATA driver complying with most major operating systems.

Featuring technologies as Advanced Wear-leveling algorithms, S.M.A.R.T, flash block management, power failure management, and ATA Secure Erase, Apacer's ADM assures users of a versatile device on data storage.

## 2. Functional Block

The ATA-Disk Module (ADM) includes the ATA controller and flash media, as well as the ATA standard interface. Figure 2-1 shows the functional block diagram.

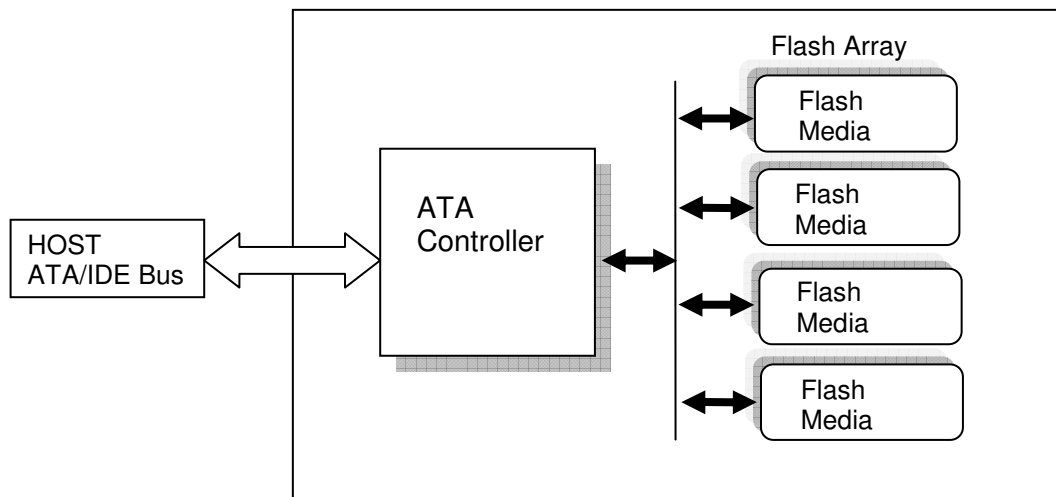

Figure 2-1: Functional block diagram

## 3. Pin Assignments

Table 3-1 lists the pin assignments with respective signal names for the 40-pin configuration. A “#” suffix indicates the active low signal. The pin type can be input, output or input/output.

**Table 3-1:** Pin assignments for the 40-pin configuration

Pin No.	Signal Name	Pin Type	I/O Type	Pin No.	Signal Name	Pin Type	I/O Type
1	RESET#	I	I2U	2	GND	-	Ground
3	D7	I/O	I1Z, O2	4	D8	I/O	I1Z, O2
5	D6	I/O	I1Z, O2	6	D9	I/O	I1Z, O2
7	D5	I/O	I1Z, O2	8	D10	I/O	I1Z, O2
9	D4	I/O	I1Z, O2	10	D11	I/O	I1Z, O2
11	D3	I/O	I1Z, O2	12	D12	I/O	I1Z, O2
13	D2	I/O	I1Z, O2	14	D13	I/O	I1Z, O2
15	D1	I/O	I1Z, O2	16	D14	I/O	I1Z, O2
17	D0	I/O	I1Z, O2	18	D15	I/O	I1Z, O2
19	GND	-	Ground	20	NC	-	Power
21	DMARQ	O	O1	22	GND	-	Ground
23	IOWR# STOP	I	I2Z	24	GND	-	Ground
25	IORD# HDMARDY# HSTROBE#	I	I2Z	26	GND	-	Ground
27	IORDY DDMARDY# DSTROBE	O	O1	28	CSEL	I	I1U
29	DMACK#	I	I2U-	30	NC/WP#*	-/I	-/I1U
31	INTRQ	O	O1	32	IOCS16#	O	O2
33	A1	I	I1Z	34	PDIAG#	I/O	I1U, O1
35	A0	I	I1Z	36	A2	I	I1Z
37	CS1FX#	I	I2Z	38	CS3FX#	I	I2Z
39	DASP#	I/O	I1U, O6	40	GND	-	Ground

\*Pin 30 is selectable as NC or WP# through a zero ohm resistor jumper. Default is NC. Note that pin 30 is a GND pin on standard ATA interface. This pin could be redesigned for host to control the write protect function on ADM

## 4. Product Specifications

### 4.1 Capacity

Capacity specification of the ATA-Disk Module (ADM) product family is available as shown in Table 4-1. It lists the specific capacity and the default numbers of heads, sectors and cylinders for each product line.

**Table 4-1:** Capacity specifications

Capacity	Total bytes*	Cylinders	Heads	Sectors	Max LBA
128 MB	128,057,344	977	8	32	250,112
256 MB	256,901,120	980	16	32	501,760
512 MB	512,483,328	993	16	63	1,000,944
1 GB	1,024,966,656	1986	16	63	2,001,888
2 GB	2,048,385,024	3969	16	63	4,000,752
4 GB	4,096,253,952	7937	16	63	8,000,496
8 GB	8,001,552,384	15504	16	63	15,628,032

\*Display of total bytes varies from file systems. LBA count addressed in the table above indicates total user storage capacity and will remain the same throughout the lifespan of the device. However, the total usable capacity of the SSD is most likely to be less than the total physical capacity because a small portion of the capacity is reserved for device maintenance usages.

### 4.2 Performance

Performances of the ATA-Flash Disk are listed in Table 4-2.

**Table 4-2:** Standard Performance specifications

Capacity	128 MB	256 MB	512 MB	1 GB	2 GB	4 GB	8 GB
<b>Performance</b>							
<b>Sustained read (MB/s)</b>	17	17	19	18	20	21	20
<b>Sustained write (MB/s)</b>	4	4	7	7	11	13	11

Note: Performances vary from flash configurations or host system settings.

### 4.3 Environmental Specification

Environmental specification of the ATA-Disk Module (ADM) product family follows the MIL-STD-810F standard which is shown in Table 4-3.

**Table 4-3:** Environmental specifications

Environment		Specification
Temperature	Operating	0°C to 70°C; -40°C to 85°C (Extended Temperature)
	Storage	-40°C to 100°C
Vibration (Non-Operating)		Sine wave: 10~2000Hz, 15G (X, Y, Z 3-axis)
Shock (Non-Operating)		Half sine wave, 1500G, 0.5msec (X, Y, Z ; All 6-axis)

### 4.4 Endurance

The endurance of a storage device is predicted by TeraBytes Written based on several factors related to usage, such as the amount of data written into the drive, block management conditions, and daily workload for the drive. Thus, key factors, such as Write Amplifications and the number of P/E cycles, can influence the lifespan of the drive.

The TBW of the device are listed in the following table.

Capacity	TeraBytes Written
128 MB	3.5
256 MB	6.9
512 MB	14.0
1 GB	27.4
2 GB	45.5
4 GB	54.7
8 GB	80.6

Notes:

- The measurement assumes the data written to the SSD for test is under a typical and constant rate.
- The measurement follows the standard metric: 1 TB (Terabyte) = 1000 GB.

---

## 5. Flash Management

### 5.1. Advanced wear-leveling algorithms

---

Flash memory devices differ from Hard Disk Drives (HDDs) in terms of how blocks are utilized. For HDDs, when a change is made to stored data, like erase or update, the controller mechanism on HDDs will perform overwrites on blocks. Unlike HDDs, flash blocks cannot be overwritten and each P/E cycle wears down the lifespan of blocks gradually. Repeatedly program/erase cycles performed on the same memory cells will eventually cause some blocks to age faster than others. This would bring flash storages to their end of service term sooner. Wear leveling is an important mechanism that level out the wearing of blocks so that the wearing-down of blocks can be almost evenly distributed. This will increase the lifespan of SSDs. Commonly used wear leveling types are Static and Dynamic.

### 5.2 S.M.A.R.T. technology

---

S.M.A.R.T. is an acronym for Self-Monitoring, Analysis and Reporting Technology, an open standard allowing disk drives to automatically monitor their own health and report potential problems. It protects the user from unscheduled downtime by monitoring and storing critical drive performance and calibration parameters. Ideally, this should allow taking proactive actions to prevent impending drive failure. Apacer SMART feature adopts the standard SMART command B0h to read data from the drive. When the Apacer SMART Utility running on the host, it analyzes and reports the disk status to the host before the device is in critical condition.

### 5.3 Built-in hardware ECC

---

The ATA-Disk Module uses BCH Error Detection Code (EDC) and Error Correction Code (ECC) algorithms which correct up to eight random single-bit errors for each 512-byte block of data. High performance is fulfilled through hardware-based error detection and correction.

### 5.4 Flash block management

---

Current production technology is unable to guarantee total reliability of NAND flash memory array. When a flash memory device leaves factory, it comes with a minimal number of initial bad blocks during production or out-of-factory as there is no currently known technology that produce flash chips free of bad blocks. In addition, bad blocks may develop during program/erase cycles. When host performs program/erase command on a block, bad block may appear in Status Register. Since bad blocks are inevitable, the solution is to keep them in control. Apacer flash devices are programmed with ECC, block mapping technique and S.M.A.R.T to reduce invalidity or error. Once bad blocks are detected, data in those blocks will be transferred to free blocks and error will be corrected by designated algorithms.

### 5.5 Power Failure Management

---

Power Failure Management plays a crucial role when experiencing unstable power supply. Power disruption may occur when users are storing data into the SSD. In this urgent situation, the controller would run multiple write-to-flash cycles to store the metadata for later block rebuilding. This urgent operation requires about several milliseconds to get it done. At the next power up, the firmware will perform a status tracking to retrieve the mapping table and resume previously programmed NAND blocks to check if there is any incompleteness of transmission.

---

## 5.6 ATA Security Erase

---

ATA Secure Erase is an ATA disk purging command currently embedded in most of the storage drives. Defined in ATA specifications, (ATA) Secure Erase is part of Security Feature Set that allows storage drives to erase all user data areas. The erase process usually runs on the firmware level as most of the ATA-based storage media currently in the market are built-in with this command. ATA Secure Erase can securely wipe out the user data in the drive and protects it from malicious attack.

## 6. Software Interface

### 6.1 Command Set

This section defines the software requirements and the format of the commands the host sends to the ATA-Disk Module (ADM). Commands are issued to the ADM by loading the required registers in the command block with the supplied parameters, and then writing the command code to the Command register. The manner in which a command is accepted varies.

**Table 6-1:** Command set (1 of 2)

Command	Code
Check-Power-Mode	E5H or 98H
Execute-Drive-Diagnostic	90H
Erase Sector(s)	C0H
Flush-Cache	E7H
Format Track	50H
Identify-Drive	ECH
Idle	E3H or 97H
Idle-Immediate	E1H or 95H
Initialize-Drive-Parameters	91H
NOP	00H
Read-Buffer	E4H
Read-DMA	C8H or C9H
Read-Multiple	C4H
Read-Sector(s)	20H or 21H
Read-Verify-Sector(s)	40H or 41H
Recalibrate	1XH
Request-Sense	03H
Security-Disable-Password	F6H
Security-Erase-Prepare	F3H
Security-Erase-Unit	F4H
Security-Freeze-Lock	F5H
Security-Set-Password	F1H
Security-Unlock	F2H
Seek	7XH
Set-Features	EFH

**Table 6-1:** Command set (2 of 2)

<b>Command</b>	<b>Code</b>
SMART	B0H
Set-Multiple-Mode	C6H
Set-Sleep-Mode	E6H or 99H
Standby	E2H or 96H
Standby-Immediate	E0H or 94H
Translate-Sector	87H
Write-Buffer	E8H
Write-DMA	CAH or CBH
Write-Multiple	C5H
Write-Multiple-Without-Erase	CDH
Write-Sector(s)	30H or 31H
Write-Sector-Without-Erase	38H
Write-Verify	3CH

## 7. Electrical Specification

**Caution: Absolute Maximum Stress Ratings** – Applied conditions greater than those listed under “Absolute Maximum Stress Ratings” may cause permanent damage to the device. This is a stress rating only and functional operation of the device at these conditions or conditions greater than those defined in the operational sections of this data sheet is not implied. Exposure to absolute maximum stress rating conditions may affect device reliability.

**Table 7-1:** Operating range

Standard Operating Temperature	0 °C to +70 °C
Extended Operating Temperature	-40 °C to +85 °C
Supply voltage	5V ± 5% (4.75-5.25V)
	3.3V ± 5% (3.135-3.465V)

**Table 7-2:** Absolute maximum power pin stress ratings

Parameter	Symbol	Conditions
Input Power	V <sub>DD</sub>	-0.3V min. to 6.5V max.
Voltage on any pin except V <sub>DD</sub> with respect to GND	V	-0.5V min. to V <sub>DD</sub> + 0.5V max.

**Table 7-3:** Recommended system power-up timing

Symbol	Parameter	Typical	Maximum	Units
T <sub>PU-READY</sub> <sup>1</sup>	Power-up to Ready Operation	200	1000	ms
T <sub>PU-WRITE</sub> <sup>1</sup>	Power-up to Write Operation	200	1000	ms

1. This parameter is measured only for initial qualification and after a design or process change that could affect this parameter.

## 8. Physical Characteristics

### 8.1 Dimension

#### 8.1.1 40-pin/180-Degree Middle Profile Without Housing

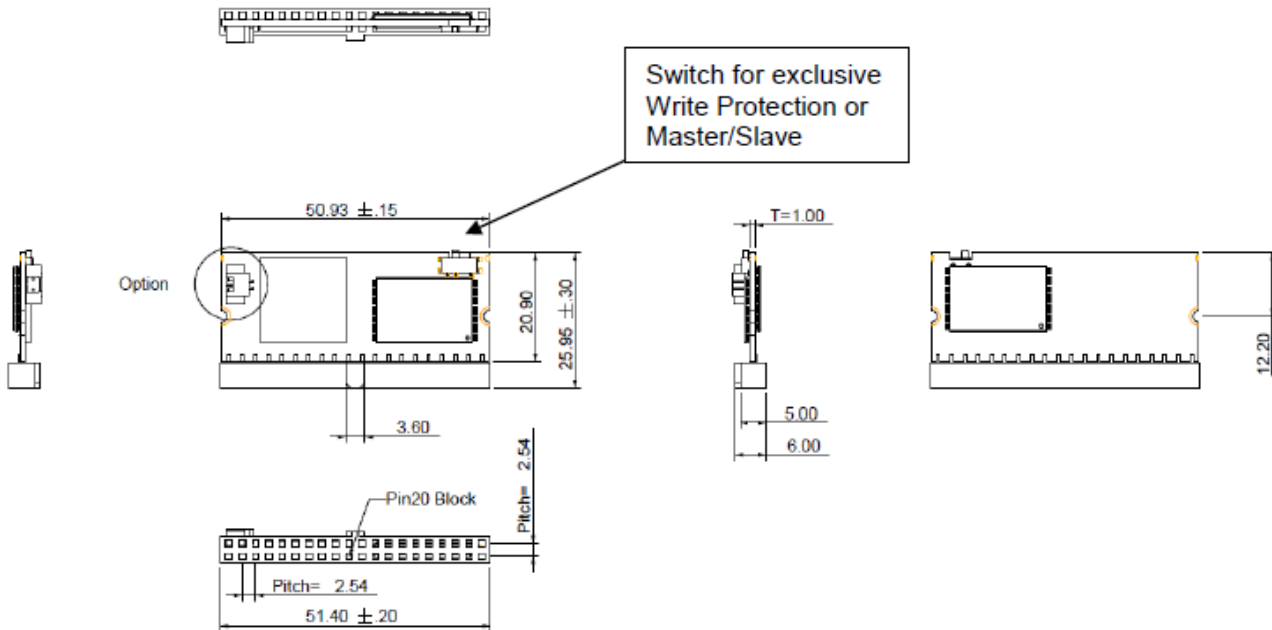

Unit: mm  
Tolerance:  $\pm 0.2$  mm

**8.1.2 40-pin/180-degree Middle Profile With Housing**

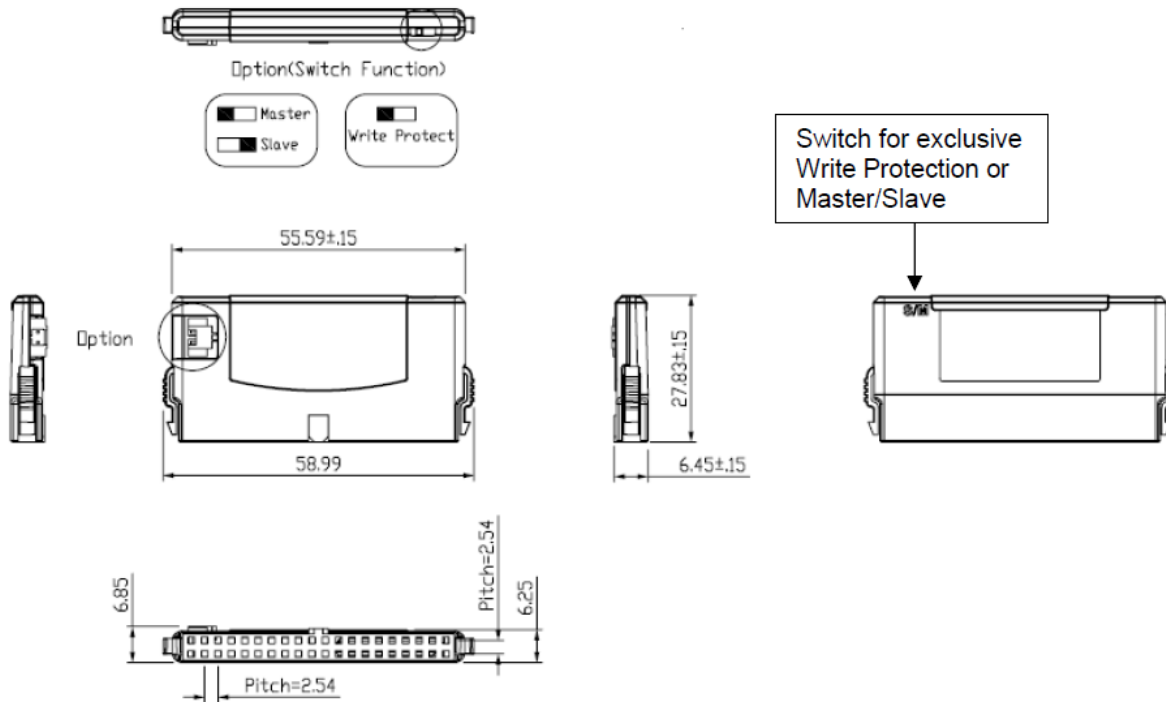

Unit: mm  
 Tolerance: ±0.2 mm

**Power Cable Type I**

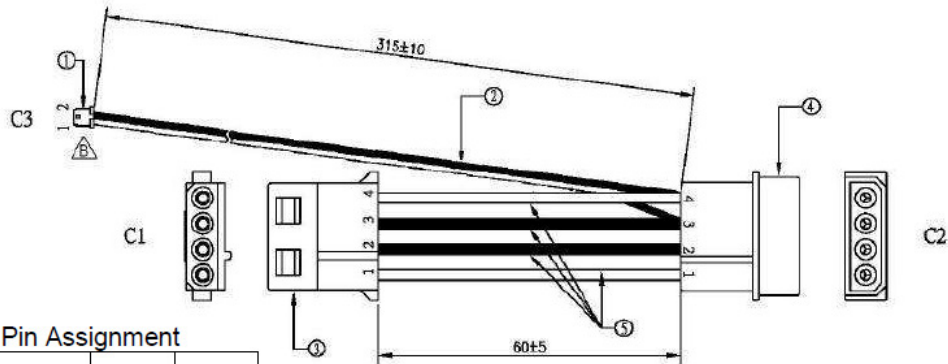

Pin Assignment

C1	Color	C2	C3
1	Yellow	1	
2	Black	2	
3	Black	3	2
4	Red	4	1

Description:

- Molex Housing Pitch 1.25mm 2P & Terminal
- Flat Cable UL1007 28AWG
- 4P Female
- 4P Male
- Wire UL1007 18AWG

**Power Cable Type II**

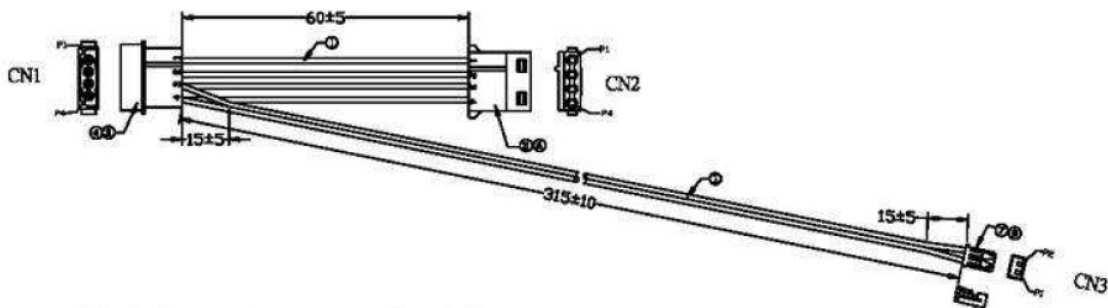

Pin Assignment

C1	Color	C2	C3
1	Yellow	1	
2	Black	2	
3	Black	3	2
4	Red	4	1

Description:

- Wire 1, WIRE UL1007 #18AWG\*1C Color:Yellow,Black,Black,Red
- Wire 2, FLAT WIRE UL1061 #28AWG\*2F Color:Black,Red
- Connector 1, Housing:Pitch 5.08 Nylon 66 UL94-V2 Female White YY-3200-H04
- Terminal 1, Terminal:Pitch 5.08 Male Brass :Tin Plated,YY-3200-T
- Connector 2, Housing:Pitch 5.08mm Nylon 66 UL94-V2 Male White YY-3100-H04
- Terminal 2, Terminal:Pitch 5.08 Female Brass:Tin Plated, YY-3100-T
- Connector 3, Housing:Pitch 1.25 Nylon 66 UL94-V0 White YY-0600-H02
- Terminal 3, Terminal:Pitch 1.25 PHOSPHOR Bronze:Tin Plated YY-0800-T

NOTE: Power Cable Type I & Type II are interchangeable.

## 9. Product Ordering Information

### 9.1 Product Code Designations

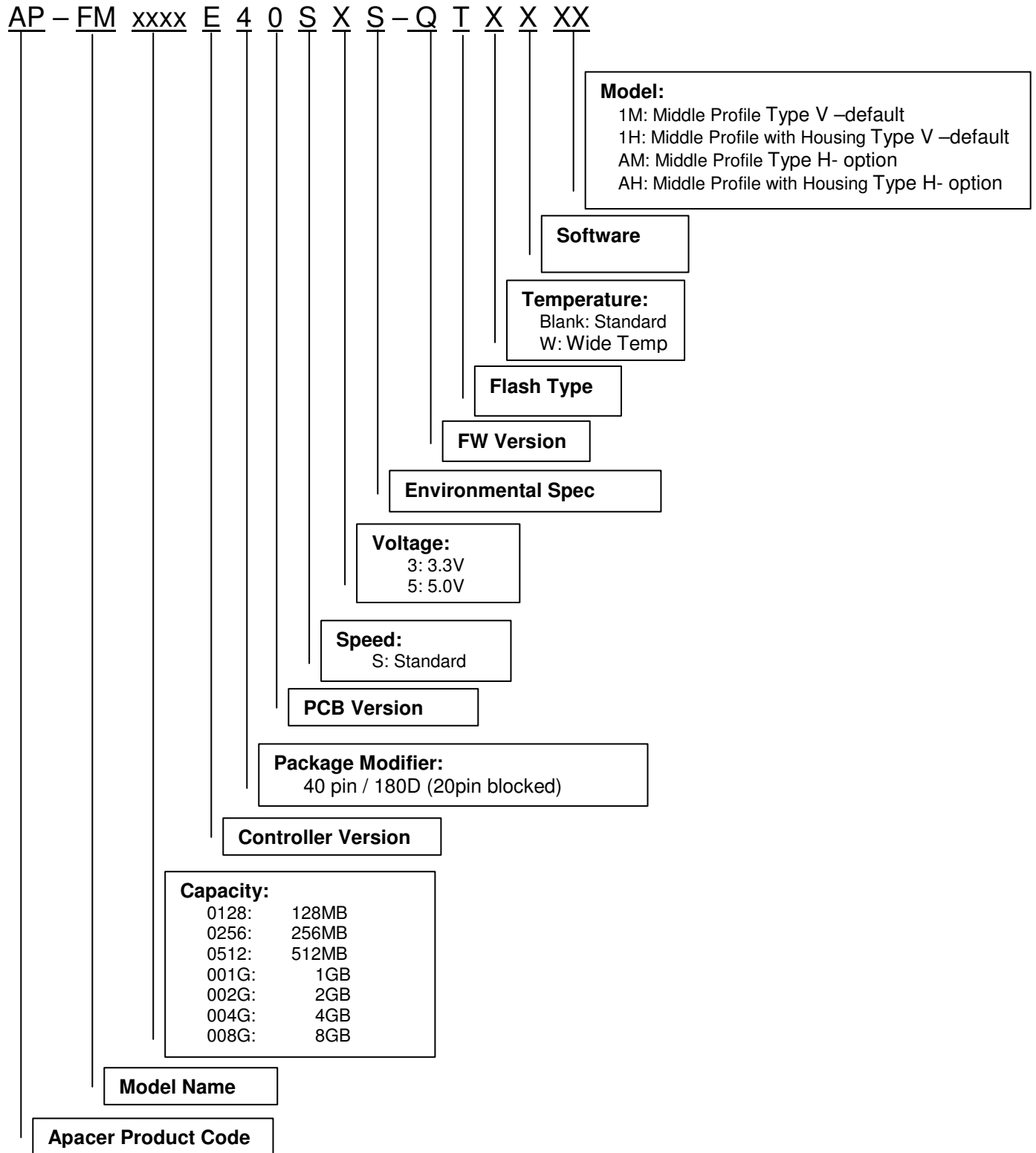

---

## 9.2 Valid Combinations

---

### 9.2.1 Standard MP

Capacity	P/N (3.3V)	P/N (5V)
128MB	AP-FM0128E40S3S-QT1M	AP-FM0128E40S5S-QT1M
256MB	AP-FM0256E40S3S-QT1M	AP-FM0256E40S5S-QT1M
512MB	AP-FM0512E40S3S-QT1M	AP-FM0512E40S5S-QT1M
1GB	AP-FM001GE40S3S-QT1M	AP-FM001GE40S5S-QT1M
2GB	AP-FM002GE40S3S-QT1M	AP-FM002GE40S5S-QT1M
4GB	AP-FM004GE40S3S-QT1M	AP-FM004GE40S5S-QT1M
8GB	AP-FM008GE40S3S-QT1M	AP-FM008GE40S5S-QT1M

### 9.2.2 Ext. Temp Standard MP

Capacity	P/N (3.3V)	P/N (5V)
128MB	AP-FM0128E40S3S-QTW1M	AP-FM0128E40S5S-QTW1M
256MB	AP-FM0256E40S3S-QTW1M	AP-FM0256E40S5S-QTW1M
512MB	AP-FM0512E40S3S-QTW1M	AP-FM0512E40S5S-QTW1M
1GB	AP-FM001GE40S3S-QTW1M	AP-FM001GE40S5S-QTW1M
2GB	AP-FM002GE40S3S-QTW1M	AP-FM002GE40S5S-QTW1M
4GB	AP-FM004GE40S3S-QTW1M	AP-FM004GE40S5S-QTW1M
8GB	AP-FM008GE40S3S-QTW1M	AP-FM008GE40S5S-QTW1M

### 9.2.3 Standard with Housing

Capacity	P/N (3.3V)	P/N (5V)
128MB	AP-FM0128E40S3S-QT1H	AP-FM0128E40S5S-QT1H
256MB	AP-FM0256E40S3S-QT1H	AP-FM0256E40S5S-QT1H
512MB	AP-FM0512E40S3S-QT1H	AP-FM0512E40S5S-QT1H
1GB	AP-FM001GE40S3S-QT1H	AP-FM001GE40S5S-QT1H
2GB	AP-FM002GE40S3S-QT1H	AP-FM002GE40S5S-QT1H
4GB	AP-FM004GE40S3S-QT1H	AP-FM004GE40S5S-QT1H
8GB	AP-FM008GE40S3S-QT1H	AP-FM008GE40S5S-QT1H

*Value Added* ATA-Disk Module III  
**AP-FMxxxxE40SXS-QTXXXX**



---

**9.2.4 Ext. Temp Standard with Housing**

<b>Capacity</b>	<b>P/N (3.3V)</b>	<b>P/N (5V)</b>
128MB	AP-FM0128E40S3S-QTW1H	AP-FM0128E40S5S-QTW1H
256MB	AP-FM0256E40S3S-QTW1H	AP-FM0256E40S5S-QTW1H
512MB	AP-FM0512E40S3S-QTW1H	AP-FM0512E40S5S-QTW1H
1GB	AP-FM001GE40S3S-QTW1H	AP-FM001GE40S5S-QTW1H
2GB	AP-FM002GE40S3S-QTW1H	AP-FM002GE40S5S-QTW1H
4GB	AP-FM004GE40S3S-QTW1H	AP-FM004GE40S5S-QTW1H
8GB	AP-FM008GE40S3S-QTW1H	AP-FM008GE40S5S-QTW1H

---

## Revision History

Revision	Date	Description	Remark
1.0	08/31/2010	Official release	
1.1	08/09/2013	Updated performance and product ordering information due to change in NAND flash use Updated the address of Taiwan headquarter Added endurance TBW section to replace MTBF	
1.2	10/08/2013	Revised the "controller version" coding rule in Product Ordering Information Revised filename version Modified mechanical drawings	

---

## Global Presence

<b>Taiwan (Headquarters)</b>	<b>Apacer Technology Inc.</b> 1F., No.32, Zhongcheng Rd., Tucheng Dist., New Taipei City 236, Taiwan R.O.C. Tel: 886-2-2267-8000 Fax: 886-2-2267-2261 <a href="mailto:amtsales@apacer.com">amtsales@apacer.com</a>
<b>U.S.A.</b>	<b>Apacer Memory America, Inc.</b> 386 Fairview Way, Suite102, Milpitas, CA 95035 Tel: 1-408-518-8699 Fax: 1-408-935-9611 <a href="mailto:sa@apacerus.com">sa@apacerus.com</a>
<b>Japan</b>	<b>Apacer Technology Corp.</b> 5F, Matsura Bldg., Shiba, Minato-Ku Tokyo, 105-0014, Japan Tel: 81-3-5419-2668 Fax: 81-3-5419-0018 <a href="mailto:jpservices@apacer.com">jpservices@apacer.com</a>
<b>Europe</b>	<b>Apacer Technology B.V.</b> Science Park Eindhoven 5051 5692 EB Son, The Netherlands Tel: 31-40-267-0000 Fax: 31-40-267-0000#6199 <a href="mailto:sales@apacer.nl">sales@apacer.nl</a>
<b>China</b>	<b>Apacer Electronic (Shanghai) Co., Ltd</b> 1301, No.251,Xiaomuqiao Road, Shanghai, 200032, China Tel: 86-21-5529-0222 Fax: 86-21-5206-6939 <a href="mailto:sales@apacer.com.cn">sales@apacer.com.cn</a>
<b>India</b>	<b>Apacer Technologies Pvt. Ltd.</b> # 535, 1st Floor, 8th cross, JP Nagar 3rd Phase, Bangalore – 560078, India Tel: 91-80-4152-9061 <a href="mailto:sales_india@apacer.com">sales_india@apacer.com</a>