

RoHS Recast Compliant **ATA Disk Module 5S**

ADM5S 44P/90D Product Specifications

August 18, 2021

Version 1.4



Apacer Technology Inc.

1F, No.32, Zhongcheng Rd., Tucheng Dist., New Taipei City, Taiwan, R.O.C

Tel: +886-2-2267-8000 Fax: +886-2-2267-2261

www.apacer.com

Specifications Overview:

- **Standard ATA/IDE Bus Interface**
 - ATA command set compatible
 - Compliant with ATA/ATAPI-8
 - ATA operating mode supports up to:
 - PIO Mode up to 4
 - Multiword DMA Mode up to 2
 - Ultra DMA Mode up to 6
- **Capacity**
 - 128, 256, 512 MB
 - 1, 2, 4, 8, 16, 32, 64 GB
- **Performance***
 - Sequential read: Up to 75 MB/sec
 - Sequential write: Up to 65 MB/sec
- **Flash Management**
 - Built-in hardware ECC
 - Global Wear Leveling
 - Flash bad-block management
 - S.M.A.R.T.
 - Power Failure Management
 - ATA Secure Erase
- **NAND Flash Type: SLC**
- **MTBF: >2,000,000 hours**
- **Temperature Range**
 - Operating:
 - Standard: 0°C to 70°C
 - Wide: -40°C to 85°C
 - Storage: -40°C to 100°C
- **Power Consumption***
 - Supply voltage: 3.3V & 5V
 - Active mode: 265 mA
 - Idle mode: 5 mA
- **Connector Type**
 - 44-pin female connector (2.00mm pitch)
- **Form Factor**
 - ATA Disk Module
 - Dimension: 45.0 x 28.0 x 6.85, unit: mm
- **RoHS Recast Compliant (Complies with 2011/65/EU Standard)**

*Varies from capacities. The values for performances and power consumptions presented are typical and may vary depending on flash configurations or platform settings. The term idle refers to the standby state of the device.

Table of Contents

1. General Descriptions	3
2. Functional Block	3
3. Pin Assignments.....	4
4. Product Specifications.....	5
4.1 Capacity.....	5
4.2 Performance	5
4.3 Environmental Specifications	6
4.4 Mean Time Between Failures (MTBF)	6
5. Flash Management	7
5.1 Built-in Hardware ECC	7
5.2 Bad Block Management	7
5.3 Global Wear Leveling	7
5.4 ATA Secure Erase.....	7
5.5 Power Failure Management	7
6. Software Interface	8
6.1 Command Set.....	8
6.2 S.M.A.R.T.	8
7. Electrical Specifications.....	9
7.1 Operating Voltage.....	9
7.2 Power Consumption	9
8. Physical Characteristics.....	10
9. Product Ordering Information.....	11
9.1 Product Code Designations.....	11
9.2 Valid Combinations.....	12

1. General Descriptions

Apacer's ATA Disk Module 5S (ADM5S) SSD delivers smooth performance and low power consumption. This device supports DMA mode up to UDMA 6 that offers advanced data transfer technology and internal memory efficiency, which effectively decreases the loading for the microprocessor. Compliant with ATA/ATAPI-8 standards, our ADM5S supports data transfer modes up to PIO 4, Multiword DMA 2, and Ultra DMA 6. Equipped with power Error Correction Coding (ECC) up to 72bit/1KB, the ADM5S can provide high data integrity. Aside from data efficiency, the ADM5S also comes with power management. The device can work at 3.3V or 5V power supply, with the output voltage automatically adjusted by the voltage regulator in the core. In addition, the built-in ECC engine can support multi-mode correction capability up to 72 bits and perform effective decoding throughput with high reliability.

ADM is a cost-effective solution with standard ATA compliance deployable at all major operating systems such as Microsoft's Windows series, Apple's Mac OS family, and Unix variants. Featuring technologies as wear leveling, S.M.A.R.T, power failure management, and ATA Secure Erase, Apacer's ADM is definitely the ideal and reliable system storage.

2. Functional Block

The ATA-Disk Module (ADM) includes the ATA controller and flash media, as well as the ATA standard interface. Figure 2-1 shows the functional block diagram.

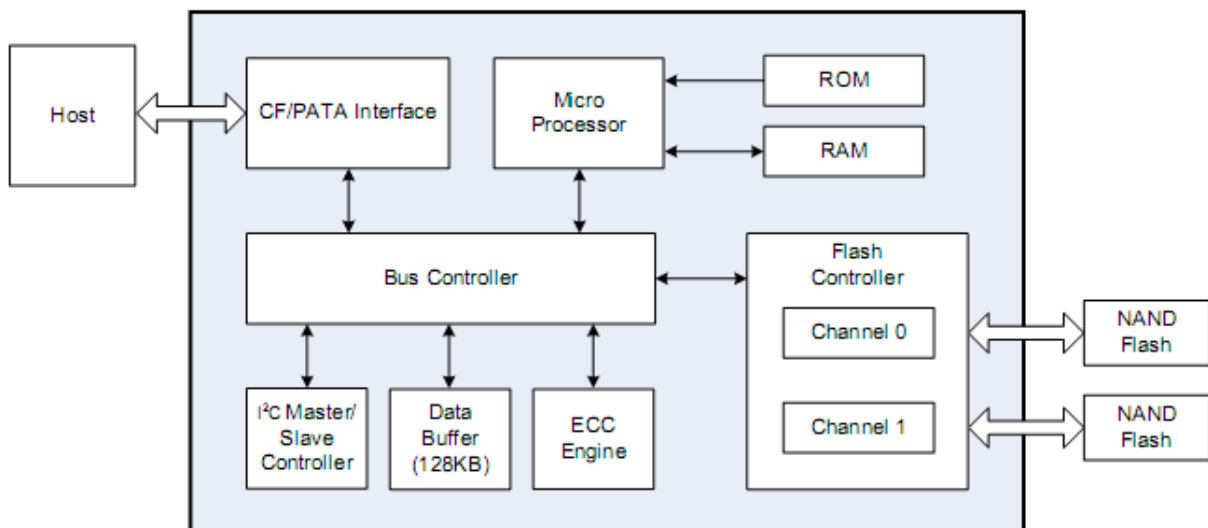

Figure 2-1 Functional Block Diagram

3. Pin Assignments

Table 3-1 lists the pin assignments with respective signal names for the 44-pin configuration. A “#” suffix indicates the active low signal. The pin type can be input, output or input/output.

Table 3-1 Pin Assignments for the 44-Pin Configuration

Pin No.	Signal Name	Pin Type	I/O Type*	Pin No.	Signal Name	Pin Type	I/O Type
1	RESET#	I	I2U	2	GND	-	Ground
3	D7	I/O	I1Z, O2	4	D8	I/O	I1Z, O2
5	D6	I/O	I1Z, O2	6	D9	I/O	I1Z, O2
7	D5	I/O	I1Z, O2	8	D10	I/O	I1Z, O2
9	D4	I/O	I1Z, O2	10	D11	I/O	I1Z, O2
11	D3	I/O	I1Z, O2	12	D12	I/O	I1Z, O2
13	D2	I/O	I1Z, O2	14	D13	I/O	I1Z, O2
15	D1	I/O	I1Z, O2	16	D14	I/O	I1Z, O2
17	D0	I/O	I1Z, O2	18	D15	I/O	I1Z, O2
19	GND	-	Ground	20	NC	-	-
21	DMARQ#	O	O1	22	GND		Ground
23	IOWR# STOP	I	I2Z	24	GND	-	Ground
25	IORD# HDMARDY# HSTROBE#	I	I2Z	26	GND	-	Ground
27	IORDY DDMARDY# DSTROBE	O	O1	28	NC/CSEL	I	I1U
29	DMACK#	I	I2U	30	NC ¹	-	-
31	INTRQ	O	O1	32	IOCS16#	O	O2
33	A1	I	I1Z	34	PDIAG#	I/O	I1U, O1
35	A0	I	I1Z	36	A2	I	I1Z
37	CS1FX#	I	I2Z	38	CS3FX#	I	I2Z
39	DASP#	I/O	I1U, O6	40	GND	-	Ground
41	VDD	-	Power	42	VDD	-	Power
43	GND	-	Ground	44	NC	-	-

*Note that pin 30 is a GND pin on standard ATA interface. This pin could be redesigned for host to control the write protect function on ADM.

4. Product Specifications

4.1 Capacity

Capacity specifications of the ATA-Disk Module (ADM) product family are available as shown in Table 4-1.

Table 4-1 Capacity Specifications (unformatted)

Capacity	Total bytes*	Cylinders	Heads	Sectors	Total LBA
128 MB	128,057,344	977	8	32	250,112
256 MB	256,901,120	980	16	32	501,760
512 MB	512,483,328	993	16	63	1,000,944
1 GB	1,011,032,064	1959	16	63	1,974,672
2 GB	2,011,226,112	3897	16	63	3,928,176
4 GB	4,011,614,208	7773	16	63	7,835,184
8 GB	8,012,390,400	15525	16	63	15,649,200
16 GB	16,013,942,784	16383	16	63	31,277,232
32 GB	32,017,047,552	16383	16	63	62,533,296
64 GB	64,023,257,088	16383	16	63	125,045,424

*Display of total bytes varies from file systems, which means not all of the bytes can be used for storage.

**Notes: 1 GB = 1,000,000,000 bytes; 1 sector = 512 bytes.

LBA count addressed in the table above indicates total user storage capacity and will remain the same throughout the lifespan of the device. However, the total usable capacity of the SSD is most likely to be less than the total physical capacity because a small portion of the capacity is reserved for device maintenance usages.

4.2 Performance

Performance of the ATA-Disk Module is listed in Table 4-2.

Table 4-2 Performance Specifications

Capacity Performance	128 MB	256 MB	512 MB	1 GB	2 GB	4 GB	8 GB	16 GB	32 GB	64 GB
Sequential Read* (MB/s)	24	24	31	31	35	65	70	75	75	75
Sequential Write* (MB/s)	11	11	20	20	28	50	60	65	65	65

Note:

Results may differ from various flash configurations or host system setting.

*Sequential performance is based on CrystalDiskMark 5.2.1 with file size 1,000MB.

4.3 Environmental Specifications

Environmental specifications of the ATA-Disk Module (ADM) follow the MIL-STD-810F standard.

Table 4-3 Environmental Specifications

Item	Specifications
Operating temp.	0°C to 70°C (Standard); -40°C to 85°C (Wide)
Non-operating temp.	-40°C to 100°C
Vibration (Non-Operating)	Sine wave: 10~2000Hz, 15G (X, Y, Z axes)
Shock (Non-Operating)	Half sine wave, 1500 G, 11 ms (X, Y, Z ; All 6 axes)

4.4 Mean Time Between Failures (MTBF)

Mean Time Between Failures (MTBF) is predicted based on reliability data for the individual components in SDM7-M. The prediction result for SDM7-M is more than 2,000,000 hours.

Note: The MTBF is predicated and calculated based on “Telcordia Technologies Special Report, SR-332, Issue 2” method.

5. Flash Management

5.1 Built-in Hardware ECC

The properties of NAND flash memory make it ideal for applications that require high integrity while operating in challenging environments. The integrity of data to NAND flash memory is generally maintained through ECC algorithms. This ATA-Flash Drive is programmed with a hardware ECC engine which correct up to 72 bits per 1KB.

5.2 Bad Block Management

Current production technology is unable to guarantee total reliability of NAND flash memory array. When a flash memory device leaves factory, it comes with a minimal number of initial bad blocks during production or out-of-factory as there is no currently known technology that produce flash chips free of bad blocks. In addition, bad blocks may develop during program/erase cycles. Since bad blocks are inevitable, the solution is to keep them in control. Apacer flash devices are programmed with ECC, block mapping technique and S.M.A.R.T to reduce invalidity or error. Once bad blocks are detected, data in those blocks will be transferred to free blocks and error will be corrected by designated algorithms.

5.3 Global Wear Leveling

Flash memory devices differ from Hard Disk Drives (HDDs) in terms of how blocks are utilized. For HDDs, when a change is made to stored data, like erase or update, the controller mechanism on HDDs will perform overwrites on blocks. Unlike HDDs, flash blocks cannot be overwritten and each P/E cycle wears down the lifespan of blocks gradually. Repeatedly program/erase cycles performed on the same memory cells will eventually cause some blocks to age faster than others. This would bring flash storages to their end of service term sooner. Global wear leveling is an important mechanism that levels out the wearing of all blocks so that the wearing-down of all blocks can be almost evenly distributed. This will increase the lifespan of SSDs.

5.4 ATA Secure Erase

ATA Secure Erase is an ATA disk purging command currently embedded in most of the storage drives. Defined in ATA specifications, (ATA) Secure Erase is part of Security Feature Set that allows storage drives to erase all user data areas. The erase process usually runs on the firmware level as most of the ATA-based storage media currently in the market are built-in with this command. ATA Secure Erase can securely wipe out the user data in the drive and protects it from malicious attack.

5.5 Power Failure Management

Power Failure Management plays a crucial role when power supply becomes unstable. Power disruption may occur when users are storing data into the SSD, leading to instability in the drive. However, with Power Failure Management, a firmware protection mechanism will be activated to scan pages and blocks once power is resumed. Valid data will be transferred to new blocks for merging and the mapping table will be rebuilt. Therefore, data reliability can be reinforced, preventing damage to data stored in the NAND Flash.

6. Software Interface

6.1 Command Set

This section defines the software requirements and the format of the commands the host sends to the ATA-Disk Module (ADM). Commands are issued to the ADM by loading the required registers in the command block with the supplied parameters, and then writing the command code to the Command register. The manner in which a command is accepted varies.

Table 6-1 Command Set

Code	Command	Code	Command
E5H or 98H	CHECK-POWER-MODE	F4H	SECURITY-ERASE-UNIT
90H	EXECUTE-DRIVE-DIAGNOSTIC	F5H	SECURITY-FREEZE-LOCK
C0H	ERASE SECTOR(S)	F1H	SECURITY-SET-PASSWORD
E7H	FLUSH-CACHE	F2H	SECURITY-UNLOCK
50H	FORMAT TRACK	7XH	SEEK
ECH	IDENTIFY-DRIVE	EFH	SET-FEATURES
E3H or 97H	IDLE	B0H	SMART
E1H or 95H	IDLE-IMMEDIATE	C6H	SET-MULTIPLE-MODE
91H	INITIALIZE-DRIVE-PARAMETERS	E6H or 99H	SET-SLEEP-MODE
00H	NOP	E2H or 96H	STANDBY
E4H	READ-BUFFER	E0H or 94H	STANDBY-LMEDIATE
C8H or C9H	READ-DMA	87H	TRANSLATE-SECTOR
C4H	READ-MULTIPLE	E8H	WRITE-BUFFER
20H or 21H	READ-SECTOR(S)	CAH or CBH	WRITE-DMA
40H or 41H	READ-VERIFY-SECTOR(S)	C5H	WRITE-MULTIPLE
1XH	RECALIBRATE	CDH	WRITE-MULTIPLE-WITHOUT-
03H	REQUEST-SENSE	30H or 31H	WRITE-SECTOR(S)
F6H	SECURITY-DISABLE-	38H	WRITE-SECTOR-WITHOUT-
F3H	SECURITY-ERASE-PREPARE		

6.2 S.M.A.R.T.

S.M.A.R.T. is an acronym for Self-Monitoring, Analysis and Reporting Technology, an open standard allowing disk drives to automatically monitor their own health and report potential problems. It protects the user from unscheduled downtime by monitoring and storing critical drive performance and attributes parameters. Ideally, this should allow taking proactive actions to prevent impending drive failure.

7. Electrical Specifications

7.1 Operating Voltage

Table 7-1 lists the supply voltage for the ATA-Disk Module.

Table 7-1 Operating Range

Item	Range
Supply Voltage	3.135-3.465V 4.75-5.25V

7.2 Power Consumption

Table 7-2 lists the power consumption for the ATA-Disk Module.

Table 7-2 Power Consumption

Capacity Mode	128 MB	256 MB	512 MB	1 GB	2 GB	4 GB	8 GB	16 GB	32 GB	64 GB
Active (mA)	110	110	125	125	130	190	220	240	245	265
Idle (mA)	5	5	5	5	5	5	5	5	5	5

Note:

*All values are typical and may vary depending on flash configurations or host system settings.

**Active power is an average power measurement performed using CrystalDiskMark with 128KB sequential read/write transfers.

8. Physical Characteristics

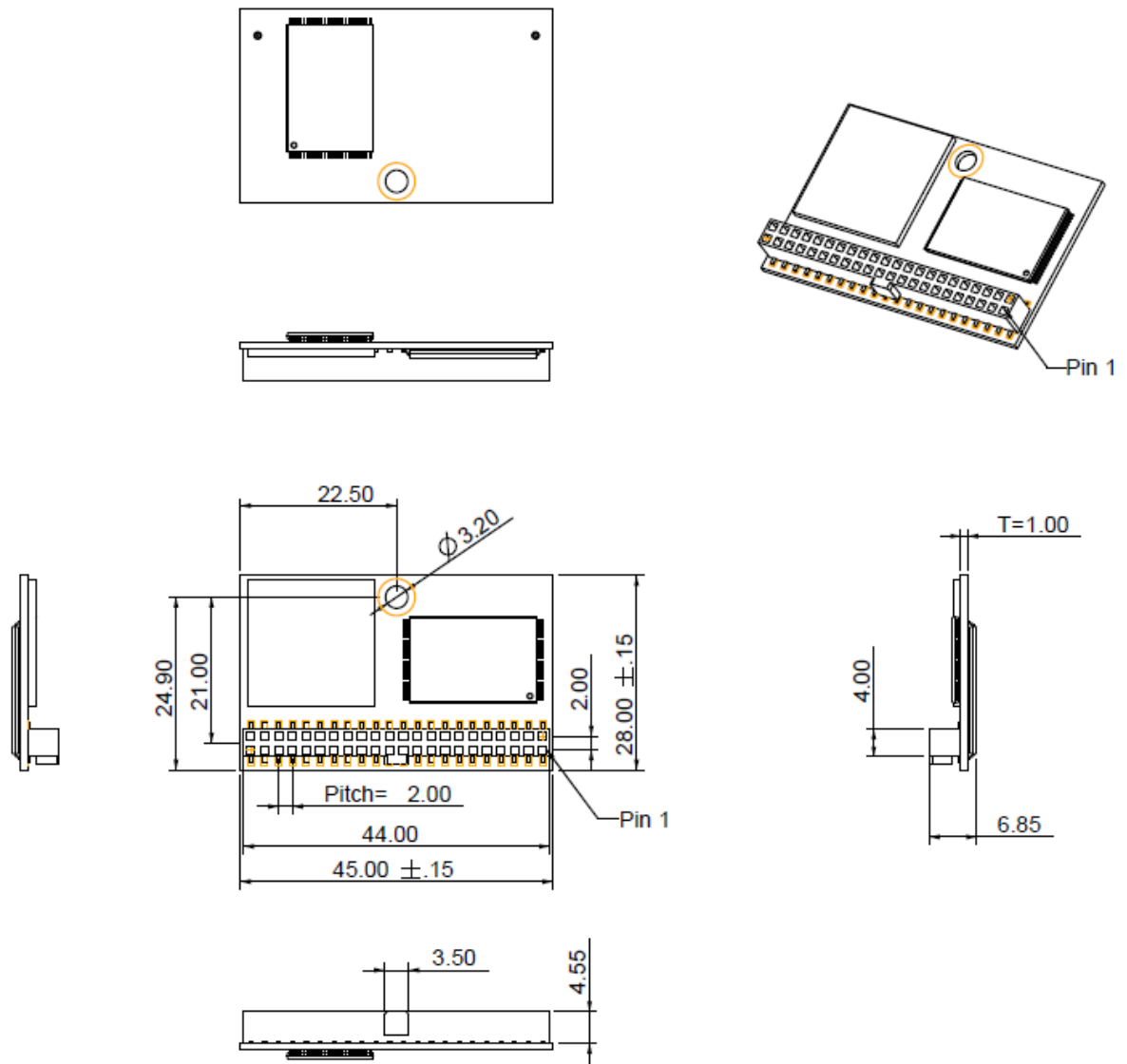
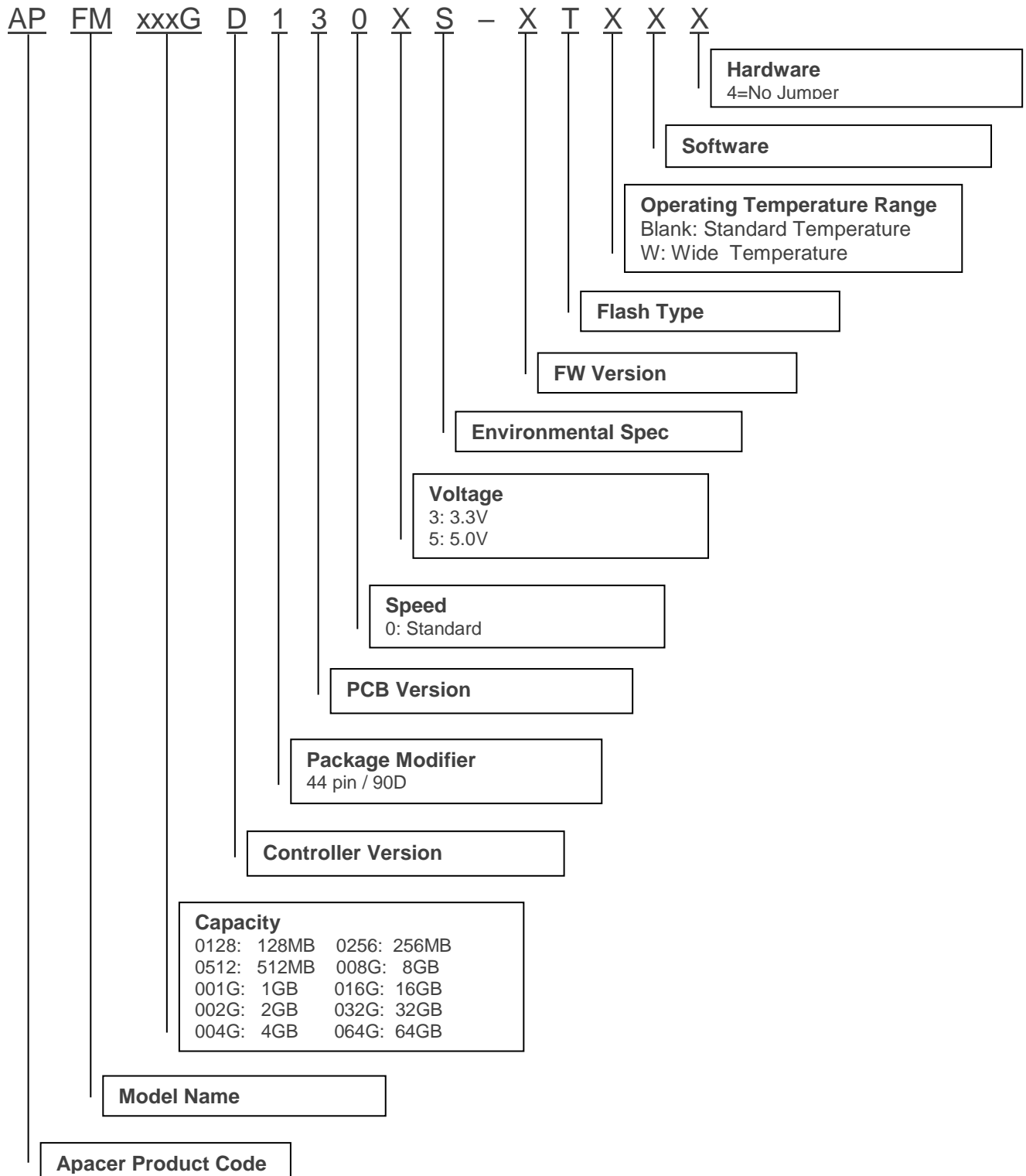

Figure 8-1 Dimensions

Unit: mm
Tolerance: ± 0.2 mm

9. Product Ordering Information

9.1 Product Code Designations



9.2 Valid Combinations

9.2.1 Standard Temperature (0°C to 70°C)

Capacity	3.3V	5V
128MB	AP-FM0128D1303S-T	AP-FM0128D1305S-T
256MB	AP-FM0256D1303S-T	AP-FM0256D1305S-T
512MB	AP-FM0512D1303S-T	AP-FM0512D1305S-T
1GB	AP-FM001GD1303S-T	AP-FM001GD1305S-T
2GB	AP-FM002GD1303S-T	AP-FM002GD1305S-T
4GB	AP-FM004GD1303S-T	AP-FM004GD1305S-T
8GB	AP-FM008GD1303S-T	AP-FM008GD1305S-T
16GB	AP-FM016GD1303S-T	AP-FM016GD1305S-T
32GB	AP-FM032GD1303S-T	AP-FM032GD1305S-T
64GB	AP-FM064GD1303S-T	AP-FM064GD1305S-T

9.2.2 Wide Temperature (-40°C to 85°C)

Capacity	3.3V	5V
128MB	AP-FM0128D1303S-TW	AP-FM0128D1305S-TW
256MB	AP-FM0256D1303S-TW	AP-FM0256D1305S-TW
512MB	AP-FM0512D1303S-TW	AP-FM0512D1305S-TW
1GB	AP-FM001GD1303S-TW	AP-FM001GD1305S-TW
2GB	AP-FM002GD1303S-TW	AP-FM002GD1305S-TW
4GB	AP-FM004GD1303S-TW	AP-FM004GD1305S-TW
8GB	AP-FM008GD1303S-TW	AP-FM008GD1305S-TW
16GB	AP-FM016GD1303S-TW	AP-FM016GD1305S-TW
32GB	AP-FM032GD1303S-TW	AP-FM032GD1305S-TW
64GB	AP-FM064GD1303S-TW	AP-FM064GD1305S-TW

9.2.3 Standard Temperature without Jumper (0°C to 70°C)

Capacity	3.3V	5V
128MB	AP-FM0128D1303S-4T	AP-FM0128D1305S-4T
256MB	AP-FM0256D1303S-4T	AP-FM0256D1305S-4T
512MB	AP-FM0512D1303S-4T	AP-FM0512D1305S-4T
1GB	AP-FM001GD1303S-4T	AP-FM001GD1305S-4T
2GB	AP-FM002GD1303S-4T	AP-FM002GD1305S-4T
4GB	AP-FM004GD1303S-4T	AP-FM004GD1305S-4T
8GB	AP-FM008GD1303S-4T	AP-FM008GD1305S-4T
16GB	AP-FM016GD1303S-4T	AP-FM016GD1305S-4T
32GB	AP-FM032GD1303S-4T	AP-FM032GD1305S-4T
64GB	AP-FM064GD1303S-4T	AP-FM064GD1305S-4T

9.2.4 Wide Temperature without Jumper (-40°C to 85°C)

Capacity	3.3V	5V
128MB	AP-FM0128D1303S-4TW	AP-FM0128D1305S-4TW
256MB	AP-FM0256D1303S-4TW	AP-FM0256D1305S-4TW
512MB	AP-FM0512D1303S-4TW	AP-FM0512D1305S-4TW
1GB	AP-FM001GD1303S-4TW	AP-FM001GD1305S-4TW
2GB	AP-FM002GD1303S-4TW	AP-FM002GD1305S-4TW
4GB	AP-FM004GD1303S-4TW	AP-FM004GD1305S-4TW
8GB	AP-FM008GD1303S-4TW	AP-FM008GD1305S-4TW
16GB	AP-FM016GD1303S-4TW	AP-FM016GD1305S-4TW
32GB	AP-FM032GD1303S-4TW	AP-FM032GD1305S-4TW
64GB	AP-FM064GD1303S-4TW	AP-FM064GD1305S-4TW

Note: Valid combinations are those products in mass production or will be in mass production. Consult your Apacer sales representative to confirm availability of valid combinations and to determine availability of new combinations.

Revision History

Revision	Description	Date
1.0	Official release	11/15/2013
1.1	Added 128MB and 256MB support	2/16/2016
1.2	Revised signal name, pin type and I/O type of pin 30 at 3. PIN Assignments	2/14/2017
1.3	Updated 9.2.3 and 9.2.4 product ordering information	10/17/2017
1.4	Updated 9.2 Valid Combinations by changing table header to 3.3V and 5V	8/18/2021

Global Presence

Taiwan (Headquarters)

Apacer Technology Inc.

1F., No.32, Zhongcheng Rd., Tucheng Dist.,
New Taipei City 236, Taiwan R.O.C.
Tel: 886-2-2267-8000
Fax: 886-2-2267-2261
amtsales@apacer.com

U.S.A.

Apacer Memory America, Inc.

46732 Lakeview Blvd., Fremont, CA 94538
Tel: 1-408-518-8699
Fax: 1-510-249-9551
sa@apacerus.com

Japan

Apacer Technology Corp.

6F, Daiyontamachi Bldg., 2-17-12, Shibaura, Minato-Ku,
Tokyo, 108-0023, Japan
Tel: 81-3-5419-2668
Fax: 81-3-5419-0018
jpservices@apacer.com

Europe

Apacer Technology B.V.

Science Park Eindhoven 5051 5692 EB Son,
The Netherlands
Tel: 31-40-267-0000
Fax: 31-40-290-0686
sales@apacer.nl

China

Apacer Electronic (Shanghai) Co., Ltd

Room D, 22/FL, No.2, Lane 600, JieyunPlaza,
Tianshan RD, Shanghai, 200051, China
Tel: 86-21-6228-9939
Fax: 86-21-6228-9936
sales@apacer.com.cn

India

Apacer Technologies Pvt Ltd,

1874, South End C Cross, 9th Block Jayanagar,
Bangalore-560069, India
Tel: 91-80-4152-9061/62
Fax: 91-80-4170-0215
sales_india@apacer.com