

***RoHS Recast Compliant***

**ADM5S**

***ADM5S 44P/180D Specifications***

**January 21, 2015**

***Version 1.3***



***Apacer Technology Inc.***

1F, No.32, Zhongcheng Rd., Tucheng Dist., New Taipei City, Taiwan, R.O.C

Tel: +886-2-2267-8000 Fax: +886-2-2267-2261

[www.apacer.com](http://www.apacer.com)

## Features:

- **Standard ATA/IDE bus interface**
  - ATA command set compatible
  - Compliant with ATA/ATAPI-8
  - ATA operating mode supports up to:
    - PIO Mode up to 4
    - Multiword DMA Mode up to 2
    - Ultra DMA Mode up to 6
- **Connector type**
  - 44-pin female connector (2.00mm pitch)
- **Power consumption (typical)\***
  - Supply voltage: 3.3V & 5V
  - Active mode: 265 mA
  - Idle mode: 5 mA
- **Performance\***
  - Sustained read: Up to 75 MB/sec
  - Sustained write: Up to 65 MB/sec
- **Capacity**
  - 512 MB
  - 1, 2, 4, 8, 16, 32 GB
- **NAND Flash Type:** SLC
- **MTBF** > 1,000,000 hours
- **Temperature ranges**
  - Operation:
    - Standard: 0°C to 70°C
    - Extended: -40°C to 85°C
  - Storage: -40°C to 100°C
- **Form Factor**
  - ATA Disk Module
  - Dimension: 49.39x27.10x6.00, unit: mm
- **Flash management**
  - Advanced wear-leveling algorithms
  - Built-in Hardware ECC
  - Flash block management
  - Power Failure Management
- **ATA Secure Erase**
- **Shock & Vibration\*\***
  - Shock: 1500 G
  - Vibration: 15 G
- **RoHS Recast compliant (2011/65/EU)**
- **S.M.A.R.T. technology**
- **Master/Slave switch (optional)**

\*Performance and power consumption addressed here are typical and may vary from flash configurations or platforms.

\*\*Non-operating

---

## Table of Contents

<b>1. General Description .....</b>	<b>3</b>
<b>2. Functional Block .....</b>	<b>3</b>
<b>3. Pin Assignments.....</b>	<b>4</b>
<b>4. Product Specification .....</b>	<b>5</b>
4.1 Capacity.....	5
4.2 Performance .....	5
4.3 Environmental Specification .....	5
<b>5. Flash Management .....</b>	<b>6</b>
5.1 Advanced wear-leveling algorithms.....	6
5.2 Built-in Hardware ECC .....	6
5.3 Flash Block Management .....	6
5.4 Power Failure Management .....	6
5.5 Mean Time Between Failures (MTBF) .....	6
<b>6. Software Interface .....</b>	<b>7</b>
6.1 Command Set.....	7
6.2 S.M.A.R.T. ....	8
6.3 ATA Secure Erase.....	8
<b>7. Electrical Specification .....</b>	<b>9</b>
<b>8. Mechanical Specifications .....</b>	<b>10</b>
8.1 Without Housing .....	10
8.2 With Housing .....	10
<b>9. Product Ordering Information.....</b>	<b>11</b>
9.1 Product Code Designations.....	11
9.2 Valid Combinations.....	12
9.2.1 Middle Profile (standard temperature series) .....	12
9.2.2 Middle Profile with Housing (standard temperature series).....	12
9.2.3 Middle Profile (extended temperature series).....	12
9.2.4 Middle Profile with Housing (extended temperature series).....	13

## 1. General Description

Apacer's ATA Disk Module 5S (ADM5S) SSD delivers smooth performance and low power consumption. This device supports DMA mode up to UDMA 6 that offers advanced data transfer technology and internal memory efficiency, which effectively decreases the loading for the microprocessor. Compliant with ATA/ATAPI-8 standards, our ADM5S supports data transfer modes up to PIO 4, Multiword DMA 2, and Ultra DMA 6. Equipped with power Error Correction Coding (ECC) up to 72bit/1KB, the ADM5S can provide high data integrity. Aside from data efficiency, the ADM5S also comes with power management. The device can work at 3.3V or 5V power supply, with the output voltage automatically adjusted by the voltage regulator in the core. In addition, the built-in ECC engine can support multi-mode correction capability up to 72 bits and perform effective decoding throughput with high reliability.

ADM is a cost-effective solution with standard ATA compliance deployable at all major operating systems such as Microsoft's Windows series, Apple's Mac OS family, and Unix variants. Featuring technologies as wear leveling, S.M.A.R.T, power failure management, and ATA Secure Erase, Apacer's ADM is definitely the ideal and reliable system storage.

## 2. Functional Block

The ATA-Disk Module (ADM) includes the ATA controller and flash media, as well as the ATA standard interface. Figure 2-1 shows the functional block diagram.

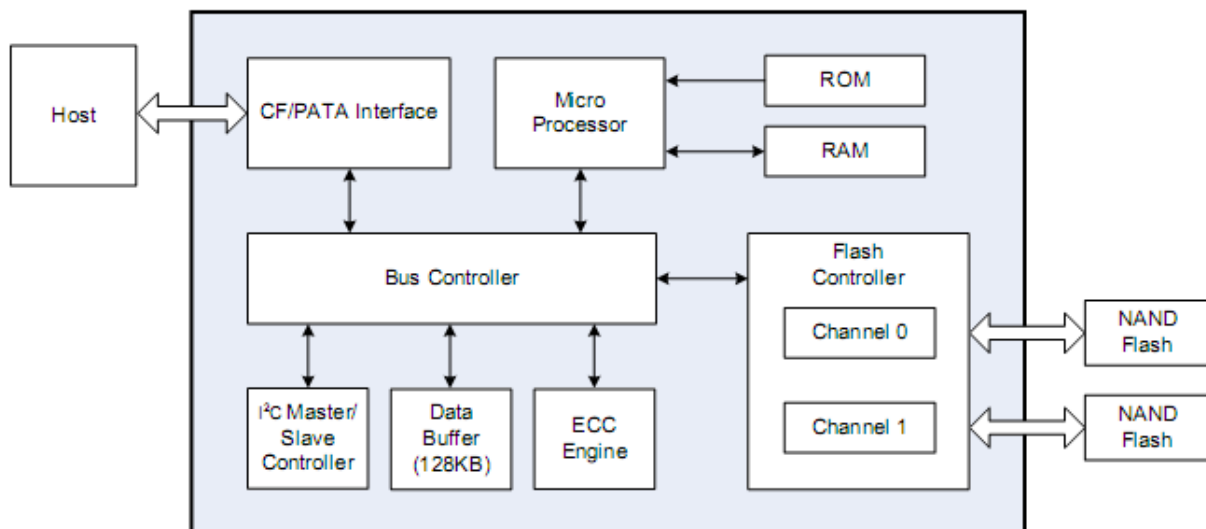

Figure 2-1 Functional block diagram

## 3. Pin Assignments

Table 3-1 lists the pin assignments with respective signal names for the 44-pin configuration. A “#” suffix indicates the active low signal. The pin type can be input, output or input/output.

**Table 3-1** Pin assignments for the 44-pin configuration

Pin No.	Signal Name	Pin Type	I/O Type*	Pin No.	Signal Name	Pin Type	I/O Type
1	RESET#	I	I2U	2	GND	-	Ground
3	D7	I/O	I1Z, O2	4	D8	I/O	I1Z, O2
5	D6	I/O	I1Z, O2	6	D9	I/O	I1Z, O2
7	D5	I/O	I1Z, O2	8	D10	I/O	I1Z, O2
9	D4	I/O	I1Z, O2	10	D11	I/O	I1Z, O2
11	D3	I/O	I1Z, O2	12	D12	I/O	I1Z, O2
13	D2	I/O	I1Z, O2	14	D13	I/O	I1Z, O2
15	D1	I/O	I1Z, O2	16	D14	I/O	I1Z, O2
17	D0	I/O	I1Z, O2	18	D15	I/O	I1Z, O2
19	GND	-	Ground	20	NC	-	-
21	DMARQ#	O	O1	22	GND	-	Ground
23	IOWR# STOP	I	I2Z	24	GND	-	Ground
25	IORD# HDMARDY# HSTROBE#	I	I2Z	26	GND	-	Ground
27	IORDY DDMARDY# DSTROBE	O	O1	28	NC/CSEL	I	I1U
29	DMACK#	I	I2U	30	NC/WP# <sup>1</sup>	-/I	-/I1U
31	INTRQ	O	O1	32	IOCS16#	O	O2
33	A1	I	I1Z	34	PDIAG#	I/O	I1U, O1
35	A0	I	I1Z	36	A2	I	I1Z
37	CS1FX#	I	I2Z	38	CS3FX#	I	I2Z
39	DASP#	I/O	I1U, O6	40	GND	-	Ground
41	VDD	-	Power	42	VDD	-	Power
43	GND	-	Ground	44	NC	-	-

\*Pin 30 is selectable as NC or WP# through a zero ohm resistor jumper. Default is NC. Note that pin 30 is a GND pin on standard ATA interface. This pin could be redesigned for host to control the write protect function on ADM

## 4. Product Specification

### 4.1 Capacity

Capacity specification of the ATA-Disk Module (ADM) product family is available as shown in Table 4-1.

**Table 4-1** Capacity specifications (unformatted)

Capacity	Total bytes	Cylinders	Heads	Sectors	Max LBA
512 MB	512,483,328	993	16	63	1,000,944
1 GB	1,011,032,064	1959	16	63	1,974,672
2 GB	2,011,226,112	3897	16	63	3,928,176
4 GB	4,011,614,208	7773	16	63	7,835,184
8 GB	8,012,390,400	15525	16	63	15,649,200
16 GB	16,013,942,784	16383	16	63	31,277,232
32 GB	32,017,047,552	16383	16	63	62,533,296

\*Cylinders, heads or sectors are not applicable for these capacities. Only LBA addressing applies

\*\*Notes: 1 GB = 1,000,000,000 bytes; 1 sector = 512 bytes.

LBA count addressed in the table above indicates total user storage capacity and will remain the same throughout the lifespan of the device. However, the total usable capacity of the SSD is most likely to be less than the total physical capacity because a small portion of the capacity is reserved for device maintenance usages.

### 4.2 Performance

Performances\* of the ATA-Disk Module are listed in below tables.

**Table 4-2** Performance specifications

Capacity	512 MB	1 GB	2 GB	4 GB	8 GB	16 GB	32 GB
<b>Performance</b>							
Sustained read (MB/s)	31	31	35	38	70	75	75
Sustained write (MB/s)	20	20	28	34	60	65	65

\*Results may differ from various flash configurations and platforms.

### 4.3 Environmental Specification

Environmental specification of the ATA-Disk Module (ADM) follows the MIL-STD-810F standard.

**Table 4-3** Environmental specifications

Environment		Specification
Temperature	Operation	Standard
		Extended
	Storage	
Vibration (Non-Operating)		Sine wave: 10~2000Hz, 15G (X, Y, Z axes)
Shock (Non-Operating)		Half sine wave, 1500 G, 11 ms (X, Y, Z ; All 6 axes)

---

## 5. Flash Management

### 5.1 Advanced wear-leveling algorithms

---

Flash memory devices differ from Hard Disk Drives (HDDs) in terms of how blocks are utilized. For HDDs, when a change is made to stored data, like erase or update, the controller mechanism on HDDs will perform overwrites on blocks. Unlike HDDs, flash blocks cannot be overwritten and each P/E cycle wears down the lifespan of blocks gradually. Repeatedly program/erase cycles performed on the same memory cells will eventually cause some blocks to age faster than others. This would bring flash storages to their end of service term sooner. Wear leveling is an important mechanism that level out the wearing of blocks so that the wearing-down of blocks can be almost evenly distributed. This will increase the lifespan of SSDs. Commonly used wear leveling types are Static and Dynamic.

### 5.2 Built-in Hardware ECC

---

The properties of NAND flash memory make it ideal for applications that require high integrity while operating in challenging environments. The integrity of data to NAND flash memory is generally maintained through ECC algorithms. This ATA-Flash Drive is programmed with a hardware ECC engine which correct up to 72 bits per 1KB.

### 5.3 Flash Block Management

---

Current production technology is unable to guarantee total reliability of NAND flash memory array. When a flash memory device leaves factory, it comes with a minimal number of initial bad blocks during production or out-of-factory as there is no currently known technology that produce flash chips free of bad blocks. In addition, bad blocks may develop during program/erase cycles. When host performs program/erase command on a block, bad block may appear in Status Register. Since bad blocks are inevitable, the solution is to keep them in control. Apacer flash devices are programmed with ECC, block mapping technique and S.M.A.R.T to reduce invalidity or error. Once bad blocks are detected, data in those blocks will be transferred to free blocks and error will be corrected by designated algorithms.

### 5.4 Power Failure Management

---

Power Failure Management plays a crucial role when experiencing unstable power supply. Power disruption may occur when users are storing data into the SSD. In this urgent situation, the controller would run multiple write-to-flash cycles to store the metadata for later block rebuilding. This urgent operation requires about several milliseconds to get it done. At the next power up, the firmware will perform a status tracking to retrieve the mapping table and resume previously programmed NAND blocks to check if there is any incompleteness of transmission.

### 5.5 Mean Time Between Failures (MTBF)

---

Mean Time Between Failures (MTBF) is predicted based on reliability data for the individual components in the drive. The prediction result for the drive is more than 1,000,000 hours.

Notes about the MTBF: The MTBF is predicated and calculated based on "Telcordia Technologies Special Report, SR-332, Issue 2" method.

## 6. Software Interface

### 6.1 Command Set

This section defines the software requirements and the format of the commands the host sends to the ATA-Disk Module (ADM). Commands are issued to the ADM by loading the required registers in the command block with the supplied parameters, and then writing the command code to the Command register. The manner in which a command is accepted varies.

**Table 6-1** Command set

Command	Code	Command	Code
Check-Power-Mode	E5H or 98H	SMART	B0H
Execute-Drive-Diagnostic	90H	Set-Multiple-Mode	C6H
Erase Sector(s)	C0H	Set-Sleep-Mode	E6H or 99H
Flush-Cache	E7H	Standby	E2H or 96H
Format Track	50H	Standby-Immediate	E0H or 94H
Identify-Drive	ECH	Translate-Sector	87H
Idle	E3H or 97H	Write-Buffer	E8H
Idle-Immediate	E1H or 95H	Write-DMA	CAH or CBH
Initialize-Drive-Parameters	91H	Write-Multiple	C5H
NOP	00H	Write-Multiple-Without-Erase	CDH
Read-Buffer	E4H	Write-Sector(s)	30H or 31H
Read-DMA	C8H or C9H	Write-Sector-Without-Erase	38H
Read-Multiple	C4H	Write-Verify	3CH
Read-Sector(s)	20H or 21H		
Read-Verify-Sector(s)	40H or 41H		
Recalibrate	1XH		
Request-Sense	03H		
Security-Disable-Password	F6H		
Security-Erase-Prepare	F3H		
Security-Erase-Unit	F4H		
Security-Freeze-Lock	F5H		
Security-Set-Password	F1H		
Security-Unlock	F2H		
Seek	7XH		
Set-Features	EFH		

---

## **6.2 S.M.A.R.T.**

S.M.A.R.T. is an acronym for Self-Monitoring, Analysis and Reporting Technology, an open standard allowing disk drives to automatically monitor their own health and report potential problems. It protects the user from unscheduled downtime by monitoring and storing critical drive performance and attributes parameters. Ideally, this should allow taking proactive actions to prevent impending drive failure.

## **6.3 ATA Secure Erase**

ATA Secure Erase is an ATA disk purging command currently embedded in most of the storage drives. Defined in ATA specifications, (ATA) Secure Erase is part of Security Feature Set that allows storage drives to erase all user data areas. The erase process usually runs on the firmware level as most of the ATA-based storage media currently in the market are built-in with this command. ATA Secure Erase can securely wipe out the user data in the drive and protects it from malicious attack.

## 7. Electrical Specification

Table 7-1 Operating range

Ambient Temperature	0°C to +70°C
Extended Temperature	-40°C to +85°C
Operating voltage	3.135-3.465V 4.75-5.25V

Table 7-2 Power consumptions

Capacity	512 MB	1 GB	2 GB	4 GB	8 GB	16 GB	32 GB
Active (mA)	125	125	130	150	220	240	245
Idle (mA)	5	5	5	5	5	5	5

\*Results were tested at 5.0V power supply and may differ from various flash configurations and platforms.

## 8. Mechanical Specifications

### 8.1 Without Housing

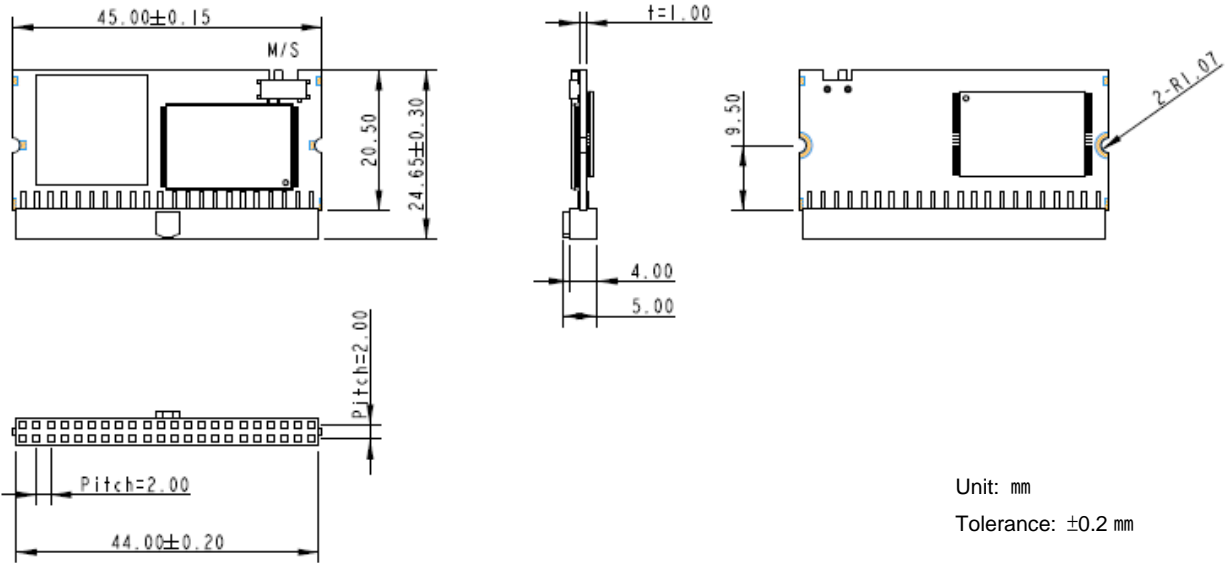

### 8.2 With Housing

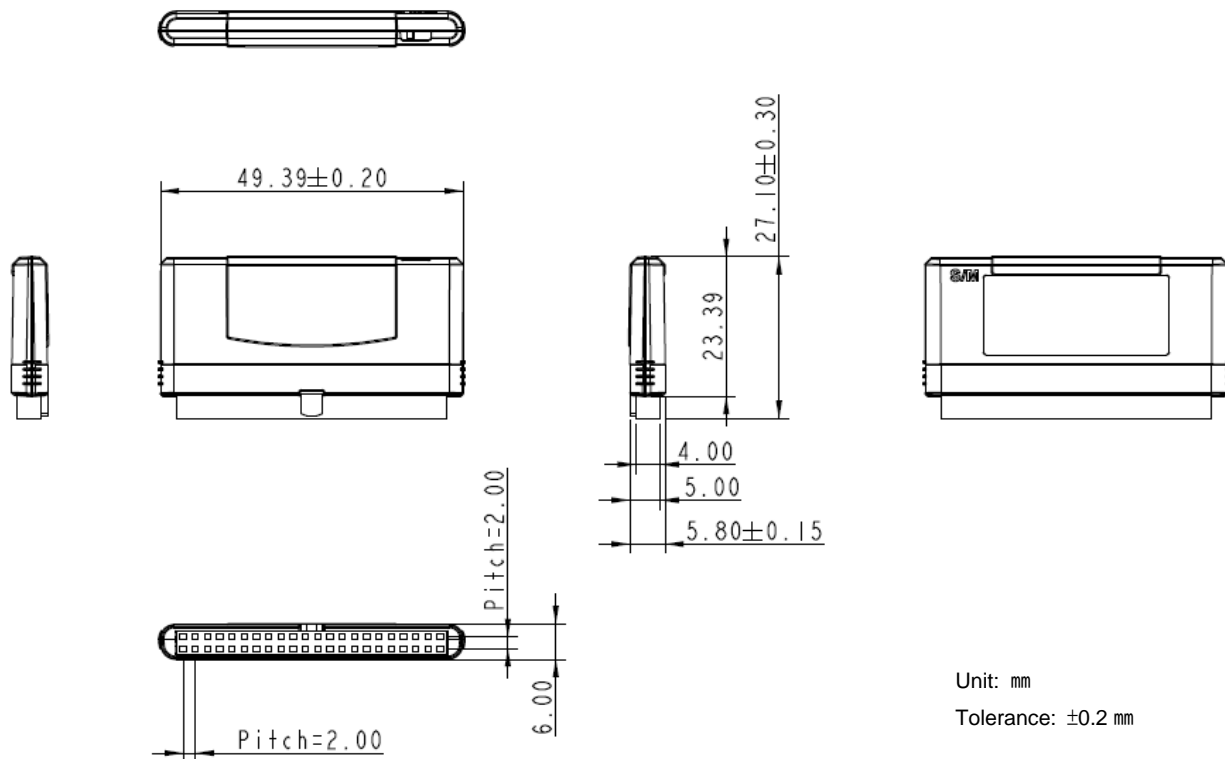

## 9. Product Ordering Information

### 9.1 Product Code Designations

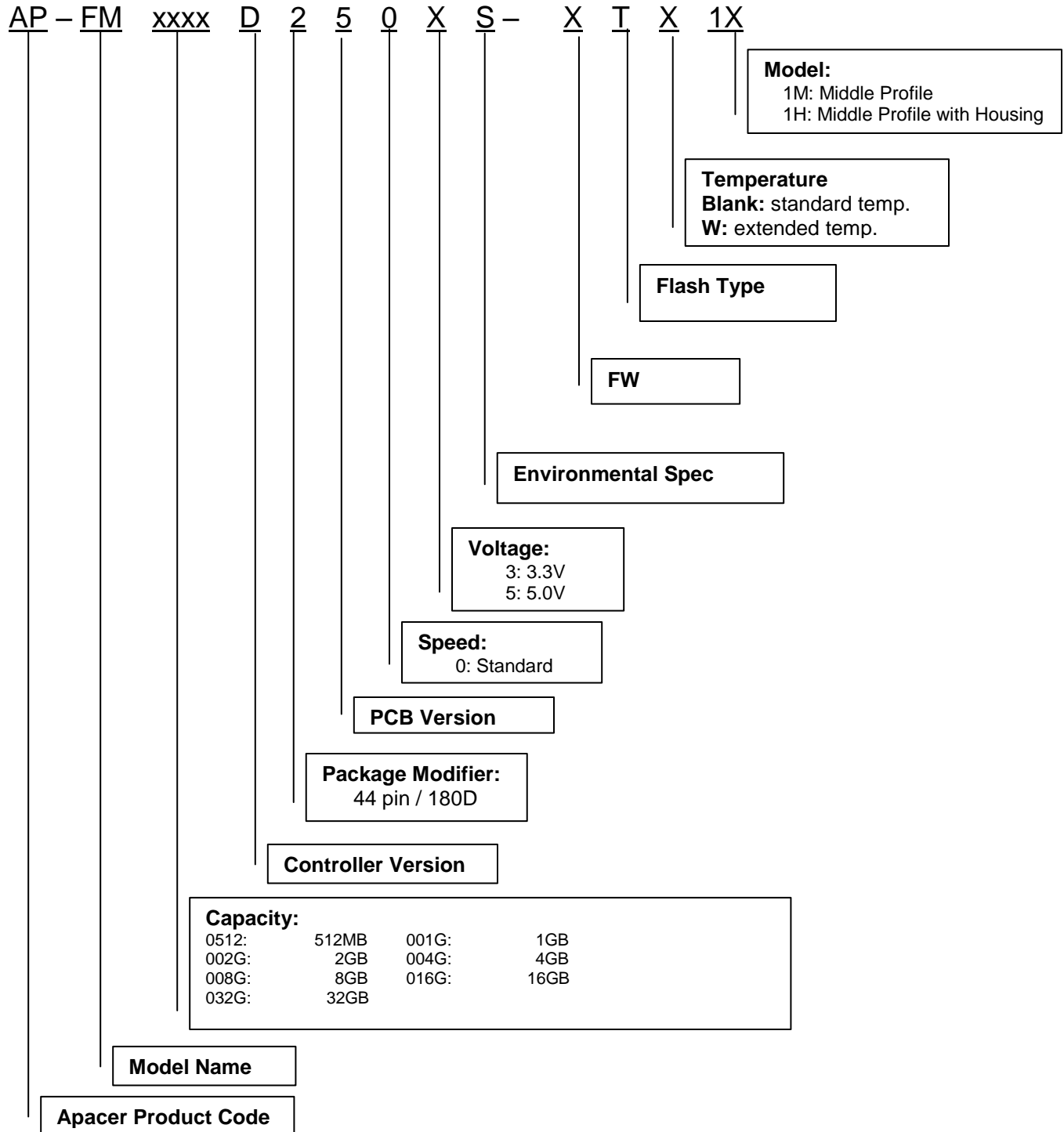

## 9.2 Valid Combinations

### 9.2.1 Middle Profile (standard temperature series)

Capacity	P/N (3.3V)	P/N (5V)
512MB	AP-FM0512D2503S-T1M	AP-FM0512D2505S-T1M
1GB	AP-FM001GD2503S-T1M	AP-FM001GD2505S-T1M
2GB	AP-FM002GD2503S-T1M	AP-FM002GD2505S-T1M
4GB	AP-FM004GD2503S-T1M	AP-FM004GD2505S-T1M
8GB	AP-FM008GD2503S-T1M	AP-FM008GD2505S-T1M
16GB	AP-FM016GD2503S-T1M	AP-FM016GD2505S-T1M
32GB	AP-FM032GD2503S-T1M	AP-FM032GD2505S-T1M

### 9.2.2 Middle Profile with Housing (standard temperature series)

Capacity	P/N (3.3V)	P/N (5V)
512MB	AP-FM0512D2503S-T1H	AP-FM0512D2505S-T1H
1GB	AP-FM001GD2503S-T1H	AP-FM001GD2505S-T1H
2GB	AP-FM002GD2503S-T1H	AP-FM002GD2505S-T1H
4GB	AP-FM004GD2503S-T1H	AP-FM004GD2505S-T1H
8GB	AP-FM008GD2503S-T1H	AP-FM008GD2505S-T1H
16GB	AP-FM016GD2503S-T1H	AP-FM016GD2505S-T1H
32GB	AP-FM032GD2503S-T1H	AP-FM032GD2505S-T1H

### 9.2.3 Middle Profile (extended temperature series)

Capacity	P/N (3.3V)	P/N (5V)
512MB	AP-FM0512D2503S-TW1M	AP-FM0512D2505S-TW1M
1GB	AP-FM001GD2503S-TW1M	AP-FM001GD2505S-TW1M
2GB	AP-FM002GD2503S-TW1M	AP-FM002GD2505S-TW1M
4GB	AP-FM004GD2503S-TW1M	AP-FM004GD2505S-TW1M
8GB	AP-FM008GD2503S-TW1M	AP-FM008GD2505S-TW1M
16GB	AP-FM016GD2503S-TW1M	AP-FM016GD2505S-TW1M
32GB	AP-FM032GD2503S-TW1M	AP-FM032GD2505S-TW1M

**ATA Disk Module**  
**AP-FMxxxxD250XS-XTX1X**



---

**9.2.4 Middle Profile with Housing (extended temperature series)**

<b>Capacity</b>	<b>P/N (3.3V)</b>	<b>P/N (5V)</b>
512MB	AP-FM0512D2503S-TW1H	AP-FM0512D2505S-TW1H
1GB	AP-FM001GD2503S-TW1H	AP-FM001GD2505S-TW1H
2GB	AP-FM002GD2503S-TW1H	AP-FM002GD2505S-TW1H
4GB	AP-FM004GD2503S-TW1H	AP-FM004GD2505S-TW1H
8GB	AP-FM008GD2503S-TW1H	AP-FM008GD2505S-TW1H
16GB	AP-FM016GD2503S-TW1H	AP-FM016GD2505S-TW1H
32GB	AP-FM032GD2503S-TW1H	AP-FM032GD2505S-TW1H

Note: Please consult with Apacer sales representatives for availabilities.

---

## Revision History

Revision	Date	Description	Remark
0.1	05/23/2014	Preliminary	
1.0	07/18/2014	Official release	
1.1	09/11/2014	Added extended temperature specification	
1.2	1/19/2015	Capacity reorganized.	
1.3	1/21/2015	Updated mechanical specifications.	

---

## Global Presence

<b>Taiwan (Headquarters)</b>	<b>Apacer Technology Inc.</b> Apacer Technology Inc. 1F., No.32, Zhongcheng Rd., Tucheng Dist., New Taipei City 236, Taiwan R.O.C. Tel: 886-2-2267-8000 Fax: 886-2-2267-2261 <a href="mailto:amtsales@apacer.com">amtsales@apacer.com</a>
<b>U.S.A.</b>	<b>Apacer Memory America, Inc.</b> 386 Fairview Way, Suite102, Milpitas, CA 95035 Tel: 1-408-518-8699 Fax: 1-408-935-9611 <a href="mailto:sa@apacerus.com">sa@apacerus.com</a>
<b>Japan</b>	<b>Apacer Technology Corp.</b> 5F, Matsura Bldg., Shiba, Minato-Ku Tokyo, 105-0014, Japan Tel: 81-3-5419-2668 Fax: 81-3-5419-0018 <a href="mailto:jpservices@apacer.com">jpservices@apacer.com</a>
<b>Europe</b>	<b>Apacer Technology B.V.</b> Science Park Eindhoven 5051 5692 EB Son, The Netherlands Tel: 31-40-267-0000 Fax: 31-40-267-0000#6199 <a href="mailto:sales@apacer.nl">sales@apacer.nl</a>
<b>China</b>	<b>Apacer Electronic (Shanghai) Co., Ltd</b> 1301, No.251,Xiaomuqiao Road, Shanghai, 200032, China Tel: 86-21-5529-0222 Fax: 86-21-5206-6939 <a href="mailto:services@apacer.com.cn">services@apacer.com.cn</a>
<b>India</b>	<b>Apacer Technologies Pvt Ltd,</b> # 535, 1st Floor, 8th cross, JP Nagar 3rd Phase, Bangalore – 560078, India Tel: 91-80-4152-9061 <a href="mailto:sales_india@apacer.com">sales_india@apacer.com</a>