

RoHS Compliant

ATA Flash Drive 257

High-capacity Value-added VA2 Specifications

January 24th, 2014

Version 1.0



Apacer Technology Inc.

1F, No.32, Zhongcheng Rd., Tucheng Dist., New Taipei City, Taiwan, R.O.C

Tel: +886-2-2267-8000 Fax: +886-2-2267-2261

www.apacer.com

Features:

- **Standard ATA/IDE bus interface**
 - ATA command set compatible
 - ATA operating mode supports up to:
 - PIO Mode-4
 - Multiword DMA Mode-2
 - Ultra DMA Mode-6
- **Connector type**
 - 44-pin male
- **Power consumption (typical)***
 - Supply voltage: 5V
 - Active mode: 280 mA
 - Idle mode: 15 mA
- **Performance***
 - Sustained read: Up to 105 MB/sec
 - Sustained write: Up to 100 MB/sec
- **Capacity**
 - 64, 128 GB
- **NAND Flash Type: SLC**
- **Temperature ranges**
 - Operation: 0°C to 70°C
 - Extended: -40°C to 85°C
 - Storage: -40°C to 100°C
- **Shock & Vibration******
 - Shock: 1500 G
 - Vibration: 15 G
- **Flash management**
 - Advanced wear-leveling algorithms
 - S.M.A.R.T.
 - Built-in Hardware ECC: 72bit/1KB
 - Flash Block Management
 - Power failure management
- **ATA Secure Erase**
- **Master/Slave jumper setting**
- **RoHS compliant**
- **Apacer Security Features by hardware architect**
 - **Full Erase:** securely eliminates data in user and free blocks
 - **Write Protect:** virtual write scheme to protect unauthorized write behaviors
 - **Destroy:** total termination of the drive so that it can no longer function as a storage media
- **Apacer Security Features by vendor-specific software commands*****
 - **CoreEraser:** provides comprehensive drive sanitization methods in 3 classes
 - **CoreDestroyer:** an ultimate drive termination measure
 - **CoreProtector:** securely protects your data in the drive at 3 levels.

*The values presented in Performance and Power consumption are typical and may vary depending on various settings and platforms.

**For more information, please see "Wafer Connector for Enabling Security Features".

***Please see "Security Features" for details.

****Non-operating

Table of Contents

1. GENERAL DESCRIPTION	3
2. FUNCTIONAL BLOCK	3
3. PIN ASSIGNMENTS	4
3.1 PIN DEFINITIONS	4
3.2 WAFER CONNECTOR FOR ENABLING SECURITY FEATURES	5
3.3 JUMPER SETTING	6
4. PRODUCT SPECIFICATION	7
4.1 CAPACITY SPECIFICATIONS	7
4.2 PERFORMANCE SPECIFICATIONS	7
4.3 ENVIRONMENTAL SPECIFICATIONS	7
5. FLASH MANAGEMENT	8
5.1 ADVANCED WEAR-LEVELING ALGORITHMS	8
5.2 S.M.A.R.T.	8
5.3 BUILT-IN HARDWARE ECC	8
5.4 FLASH BLOCK MANAGEMENT	8
5.5 POWER FAILURE MANAGEMENT	9
6. SECURITY FEATURES	10
6.1 COREERASER	10
6.2 COREDESTROYER	10
6.3 COREPROTECTOR	10
7. SOFTWARE INTERFACE	11
7.1 COMMAND SET	11
7.2 ATA SECURE ERASE	11
8. ELECTRICAL SPECIFICATION	12
9. PHYSICAL CHARACTERISTICS	13
10. PRODUCT ORDERING INFORMATION	14
10.1 PRODUCT CODE DESIGNATIONS	14
10.2 VALID COMBINATIONS	15

1. General Description

Apacer's ATA-Flash Drive (AFD) is a high-performance, solid state drive (SSD) designed to replace a conventional IDE hard disk drive. AFD supports standard ATA/IDE protocol and can be plugged into a standard IDE connector commonly found in desktop or portable PCs. It is more rugged, reliable and power-efficient compared to the mechanical hard drive and is designed for use in rugged laptops, military devices, thin clients, Point of Sale (POS) terminals, telecom, medical instruments, surveillance systems and industrial PCs. AFD also offers users selectable Master/Slave operation through an external jumper setting. Apacer AFD Series is the best instant replacement for high-maintenance HDD where reliability is a major concern.

AFD includes a built-in microcontroller and file management firmware that communicates through with the ATA standard interfaces. AFD is designed to work at 5 Volts, support the standard ATA/IDE protocol up to PIO Mode-4, Multiword DMA Mode-2, and Ultra DMA Mode-6 interfaces, and use a standard ATA driver that fits to most of the mainstream operating systems. Featuring technologies as Advanced Wear-leveling algorithms, S.M.A.R.T, Flash Block Management, Power Failure Management, and ATA Secure Erase, the AFD device assures users of security in storage applications.

2. Functional Block

The ATA-Flash Drive (AFD) includes the ATA controller and flash media, as well as the ATA standard interface. Figure 2-1 shows the functional block diagram.

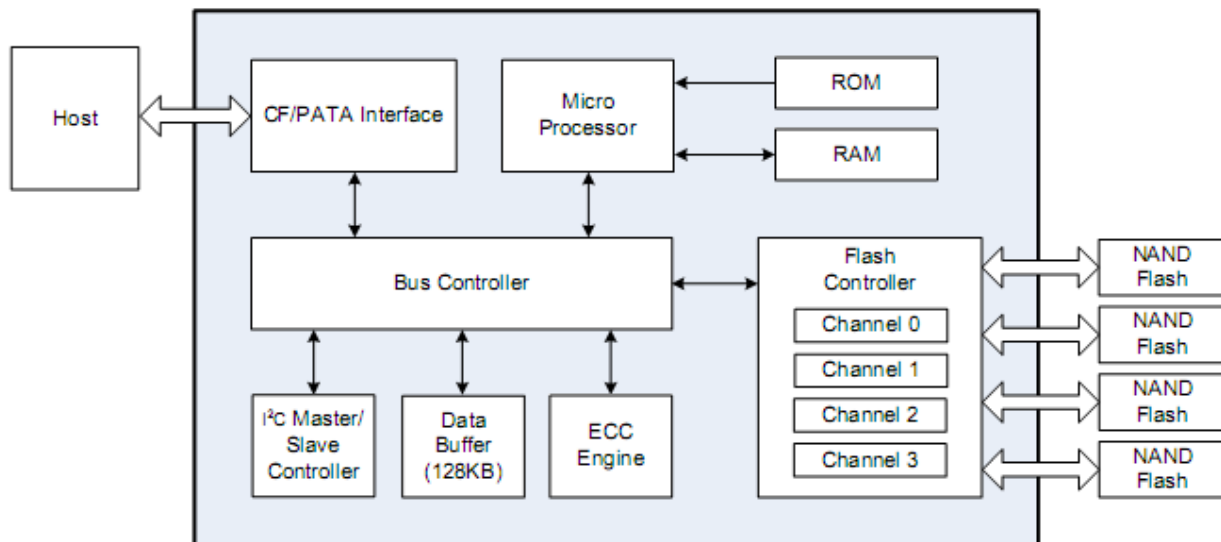

Figure 2-1: ATA-Flash Drive functional block diagram

3. Pin Assignments

3.1 Pin Definitions

Table 3-1 lists the pin assignments with respective signal names for the 44-pin configuration. A “#” suffix indicates the active low signal. The pin type can be input, output or input/output.

Figure 3-1: ATA-Flash Drive 44-pin Connector

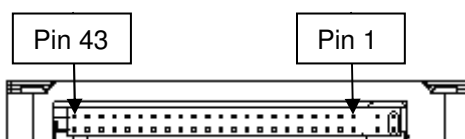

Table 3-1: Pin assignments for the 44-pin configuration

Pin No.	Signal Name	Pin Type	Pin No.	Signal Name	Pin Type
1	RESET#	I	2	GND	-
3	D7	I/O	4	D8	I/O
5	D6	I/O	6	D9	I/O
7	D5	I/O	8	D10	I/O
9	D4	I/O	10	D11	I/O
11	D3	I/O	12	D12	I/O
13	D2	I/O	14	D13	I/O
15	D1	I/O	16	D14	I/O
17	D0	I/O	18	D15	I/O
19	GND	-	20	NC	-
21	DMARQ	O	22	GND	-
23	IOWR#	I	24	GND	-
25	IORD# HDMARDY# HSTROBE#	I	26	GND	-
27	IORDY DDMARDY# DSTROBE	O	28	CSEL	I
29	DMACK#	I	30	GND	-
31	INTRQ	O	32	IOCS16#	O
33	A1	I	34	PDIAG#	I/O
35	A0	I	36	A2	I
37	CS1FX#	I	38	CS3FX#	I
39	DASP#	I/O	40	GND	-
41	VDD	-	42	VDD	-
43	GND	-	44	NC	-

3.2 Wafer Connector for Enabling Security Features

Table 3-2 lists the pin assignments of the wafer connector. Some of the pins on the wafer are designed to enable certain tasks.

Note: The host may implement a corresponding wafer connector on the motherboard and establish connections via a cable.

Figure 3-2: Wafer Connector



Table 3-2: Pin assignments for the 8-pin configuration

Pin No.	Pin Definition
1	GND
2	Erase
3	GND
4	Destroy
5	GND
6	Write Protect
7	NC
8	DASP

Erase

The pin 2 of this wafer can trigger “Erase” function, which is defined as “Full Erase” in Apacer security features. Full Erase sanitizes the LBA and eliminates all the physical blocks in User Block and Free Block. Drive will have to be reinitialized upon the completion of the erase action. The device will practically act as a raw disk as cells in the drive would display “FF” (or “00”).

Destroy

The pin 4 of this wafer can enable “Destroy” function. This measure aims at destroying not only the blocks in User Block and Free Block, but more importantly, firmware, mapping/allocation table and other maintenance mechanisms in the System Block in an SSD. With the System Block totally terminated, the SSD can no longer function as storage media.

Write Protect

The pin 6 can enable “Write Protect” function. To protect unauthorized data writes, Apacer implements Write Protect that functions as “Virtual Write” that allows write commands to go through the flash controller and data is temporarily stored. But since the process is “virtual”, none of the data has been written to the flash. When the host resets or restarts the system, all the temporarily stored data will disappear.

Security Features	Triggered Pins
Erase	Short pin 1 and pin 2
Destroy	Short pin 3 and pin 4
Write Protect	Short pin 5 and pin 6

3.3 Jumper Setting

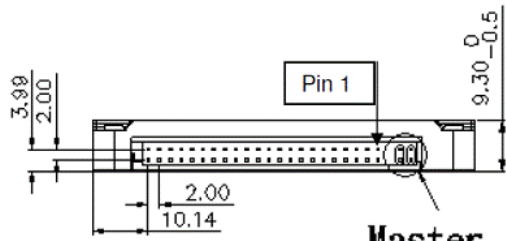

Master Slave Cable Sel.

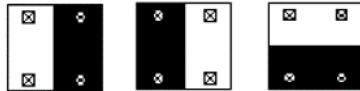

4. Product Specification

4.1 Capacity Specifications

Capacity specification of the ATA-Flash Drive (AFD) lists out unformatted, out-of-box capacity information.

Table 4-1: AFD capacity specifications

Capacity	Total bytes*	Cylinders**	Heads	Sectors	Max LBA
64 GB	64,023,257,088	16383	16	63	125,045,424
128 GB	128,035,676,160	16383	16	63	250,069,680

*Display of total bytes varies from file systems.

**Notes: 1 GB = 1,000,000,000 bytes; 1 sector = 512 bytes.

LBA count addressed in the table above indicates total user storage capacity and will remain the same throughout the lifespan of the device. However, the total usable capacity of the SSD is most likely to be less than the total physical capacity because a small portion of the capacity is reserved for device maintenance usages.

4.2 Performance Specifications

Table 4-2: Performance specifications

Capacity	64 GB	128 GB
Performance		
Sustained read (MB/s)	105	105
Sustained write (MB/s)	95	100

Note: Performance varies from flash configurations or host system configurations

4.3 Environmental Specifications

Environmental specification of the ATA-Flash Drive follows the standards of MIL-STD-810F.

Table 4-3: ATA-Flash Drive environmental specifications

Item	Criteria
Non-Operating Temperature	-40~100 (°C)
Operating Temperature	0°C to 70°C (Standard); -40°C to 85°C (Extended)
Vibration*	Sine wave: 15(G), 10~2000(Hz); X, Y, Z axis
Shock*	1500(G), 0.5(ms), ±X, ±Y, ±Z axis
Humidity	5% to 95% RH (Non-condensing)

*Non-operating

5. Flash Management

5.1 Advanced wear-leveling algorithms

Flash memory devices differ from Hard Disk Drives (HDDs) in terms of how blocks are utilized. For HDDs, when a change is made to stored data, like erase or update, the controller mechanism on HDDs will perform overwrites on blocks. On the other hand, NAND flash storage adopt flash as their primary media. Unlike HDDs, flash blocks cannot be overwritten and each P/E cycle wears down the lifespan of blocks gradually. Repeatedly program/erase cycles performed on the same memory cells will eventually cause some blocks to age faster than others. This would bring flash storages to their end of service term earlier. Wear leveling is an important mechanism that level out the wearing of blocks so that the wearing-down of blocks can be almost evenly distributed. This will increase the lifespan of SSDs. Commonly used wear leveling types are Static and Dynamic.

5.2 S.M.A.R.T.

S.M.A.R.T. is an acronym for Self-Monitoring, Analysis and Reporting Technology, an open standard allowing disk drives to automatically monitor their own health and report potential problems. It protects the user from unscheduled downtime by monitoring and storing critical drive performance and attributes parameters. Ideally, this should allow taking proactive actions to prevent impending drive failure.

Apacer devices use the standard SMART command B0h to read data out from the drive to activate our SMART feature that complies with the ATA/ATAPI specifications. Based on the SFF-8035i Rev. 2.0 specifications, SMART Attribute IDs shall include Initial bad block count, Bad block count, Spare block count, Maximum erase count, Average erase count and Power cycle. When the SMART Utility running on the host, it analyzes and reports the disk status to the host before the device reaches in critical condition.

5.3 Built-in Hardware ECC

The properties of NAND flash memory make it ideal for applications that require high integrity while operating in challenging environments. The integrity of data to NAND flash memory is generally maintained through ECC algorithms. This ATA-Flash Drive is programmed with a hardware ECC engine which correct up to 72 bits per 1KB.

5.4 Flash Block Management

Current process technology is unable to guarantee total reliability of NAND flash memory array. When a flash memory device leaves factory, it comes with a highly minimal number of initial bad block during production or out-of-factory as there is no currently known technology that produce flash chips free of bad blocks. On the other hand, bad blocks may develop during program/erase cycles. When host performs program/erase command on a block, bad block may appear in Status Register. Since bad blocks are inevitable, the solution is to keep them in control. Apacer flash devices are programmed with ECC, block mapping technique and S.M.A.R.T to reduce invalidity or error. Once bad blocks are detected, data in those blocks will be transferred to free blocks and error will be corrected by designated algorithms.

5.5 Power Failure Management

Power Failure Management plays a crucial role when experiencing unstable power supply. Power disruption may occur when users are storing data into the SSD. In this urgent situation, the controller would run multiple write-to-flash cycles to store the metadata for later block rebuilding. This urgent operation requires about several milliseconds to get it done. At the next power up, the firmware will perform a status tracking to retrieve the mapping table and resume previously programmed NAND blocks to check if there is any incompleteness of transmission.

6. Security Features

6.1 CoreEraser

CoreEraser Technology comes in 3 different classes, indicating different degrees of secure erasure. The Class 1 is defined as Quick Erase. Apacer developed Quick Erase function for urgent cases when there is not enough time for a thorough deletion of the whole drive. Quick Erase eliminates FAT table and the MBR (Master Boot Record) in LBA that manages partition tables and boot sector during system start-up process. With the MBR and FAT table erased, the drive would appear as uninitialized and mapping links between LBA and physical blocks are erased. In order to access the drive, re-initialization and FAT table rebuild are necessary.

CoreEraser Class2 is defined as Full Erase, which functions as a more comprehensive Quick Erase. Full Erase sanitizes the LBA and eliminates all the physical blocks in User Block and Free Block. Drive will have to be reinitialized upon the completion of the erase action. The device will practically act as a raw disk as cells in the drive would display “FF” (or “00”).

The Class 3 is named as MIL Erase (Military Erase). Apacer MIL Erase includes a list of globally certified drive purge methods that meet the military and industrial standards, such as NSA 9-12. Most of them sanitize MBR, FAT table as well as user & free blocks by erasing the blocks, overwriting with random data. These certified erase features are widely approved, providing confidence in secure data erasure. The standards included in MIL Erase are DoD 5220.22-M, NSA Manual 130-2, USA-AF AFSSI 5020, USA-Army 380-19, USA Navy NAVSO P-5239-26, NISPOMSUP Chap 8, Sect. 8-501, IREC (IRIG) 106, and NSA 9-12 (Gen.2).

6.2 CoreDestroyer

CoreDestroyer Technology is the ultimate disk termination solution. The technology aims at destroying not only the blocks in User Block and Free Block, but more importantly, firmware, mapping/allocation table and other maintenance mechanisms in the System Block in an SSD. With the System Block totally terminated, the SSD can no longer function as storage media.

6.3 CoreProtector

CoreProtector comes in with two handy features for internal drive protection: Data Protect, Write Protect and Device Protect.

Data Protect: Apacer SSDs come with a unique 512-byte Security Key when they leave the factory. The key is activated whenever the host boots up. The host BIOS will retrieve the 512-byte key data and the host user can use it as password identifications for accessing certain application programs or booting up process. Failure to match the key will result in aborted operations.

Write Protect: Apacer Write Protect functions as “Virtual Write” that allows write commands to go through the flash controller and data is temporarily stored. But since the process is “virtual”, none of the data has been written to the flash. When the host resets or restarts the system, all the temporarily stored data will disappear.

Device Protect: Device Protect is a more comprehensive security solution from Write Protect. Device Protect not only integrates our Write Protect scheme, but also provides protection that prevents unauthorized individuals to read files in the device. When the function is enabled, Device Protect would allow read commands to go through the flash controller, but not able to read actual data in the device. Unauthorized read attempts would retrieve invalid data only.

For more information about security features, please refer to our white papers. Our white papers will be supplied upon request.

7. Software Interface

7.1 Command Set

This section defines the software requirements and the format of the commands the host sends to the ATA-Flash Drive (AFD). Commands are issued to the AFD by loading the required registers in the command block with the supplied parameters, and then writing the command code to the command register. The manner in which a command is accepted varies.

Code	Command	Code	Command
E5h	Check Power Mode	F6h	Security Disable Password
92h	Download Microcode	F3h	Security Erase Prepare
90h	Execute Device Diagnostic	F4h	Security Erase Unit
E7h	Flush Cache	F5h	Security Freeze Lock
EAh	Flush Cache EXT	F1h	Security Set Password
ECh	Identify Device	F2h	Security Unlock
A1h	Identify Packet Device	70h	Seek
E3h	Idle	EFh	Set Features
E1h	Idle Immediate	F9h	Set Max*
91h	Initialize Device Parameters	91h	Set Max Address EXT
00h	NOP	C6h	Set Multiple Mode
E4h	Read Buffer	E6h	Sleep
C8h	Read DMA	B0h	SMART
25h	Read DMA EXT	E2h	Standby
C4h	Read Multiple	E0h	Standby Immediate
29h	Read Multiple EXT	E8h	Write Buffer
F8h	Read Native Max Address	CAh	Write DMA
27h	Read Native Max Address EXT	35h	Write DMA EXT
20h	Read Sector	C5h	Write Multiple
24h	Read Sector EXT	39h	Write Multiple EXT
40h	Read Verify Sectors	30h	Write Sector
42h	Read Verify Sectors EXT	34h	Write Sector EXT
10h	Recalibrate		

*The command can be configured as "Set Max Lock", "Set Max Address", "Set Max Set Password", "Set Max Unlock" and "Set Max Freeze Lock", depending on the transfer mode in operation.

7.2 ATA Secure Erase

ATA Secure Erase is an ATA disk purging command currently embedded in most of the storage drives. Defined in ATA specifications, (ATA) Secure Erase is part of Security Feature Set that allows storage drives to erase all user data areas. The erase process usually runs on the firmware level as most of the ATA-based storage media currently in the market are built-in with this command. ATA Secure Erase can securely wipe out the user data in the drive and protects it from malicious attack.

8. Electrical Specification

Table 7-1: ATA-Flash Drive operating voltage & operating temperature

Ambient Temperature	Power supply
0°C to 70°C (standard)	4.75-5.25V
-40°C to 85°C (extended)	

Table 7-2: Power consumption

Modes	Capacity	64 GB	128 GB
	Active (mA)		255
Idle (mA)		15	15

Note: Power consumption varies from flash configurations or host system configurations

9. Physical Characteristics

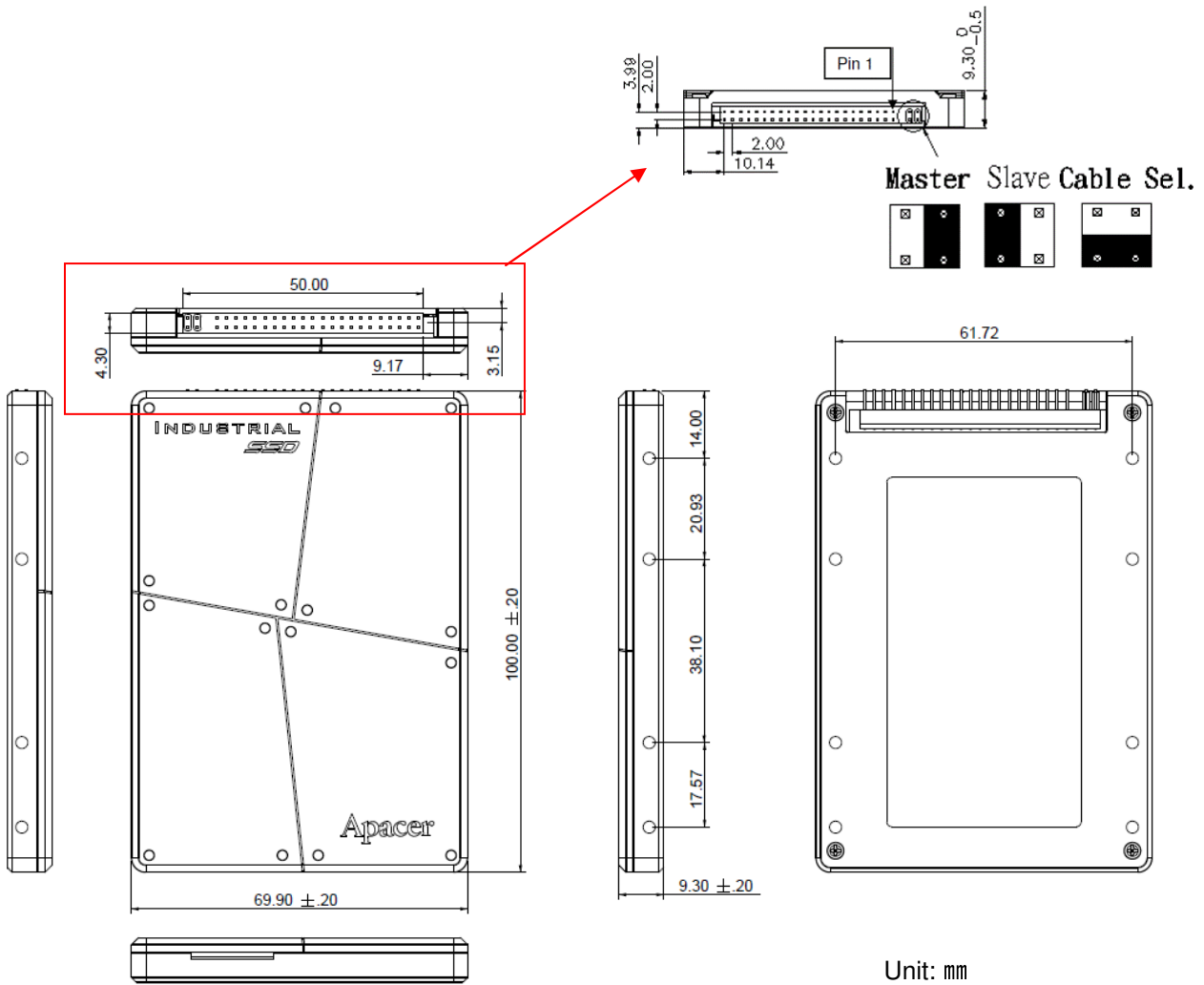

Locate the wafer connector



10. Product Ordering Information

10.1 Product Code Designations

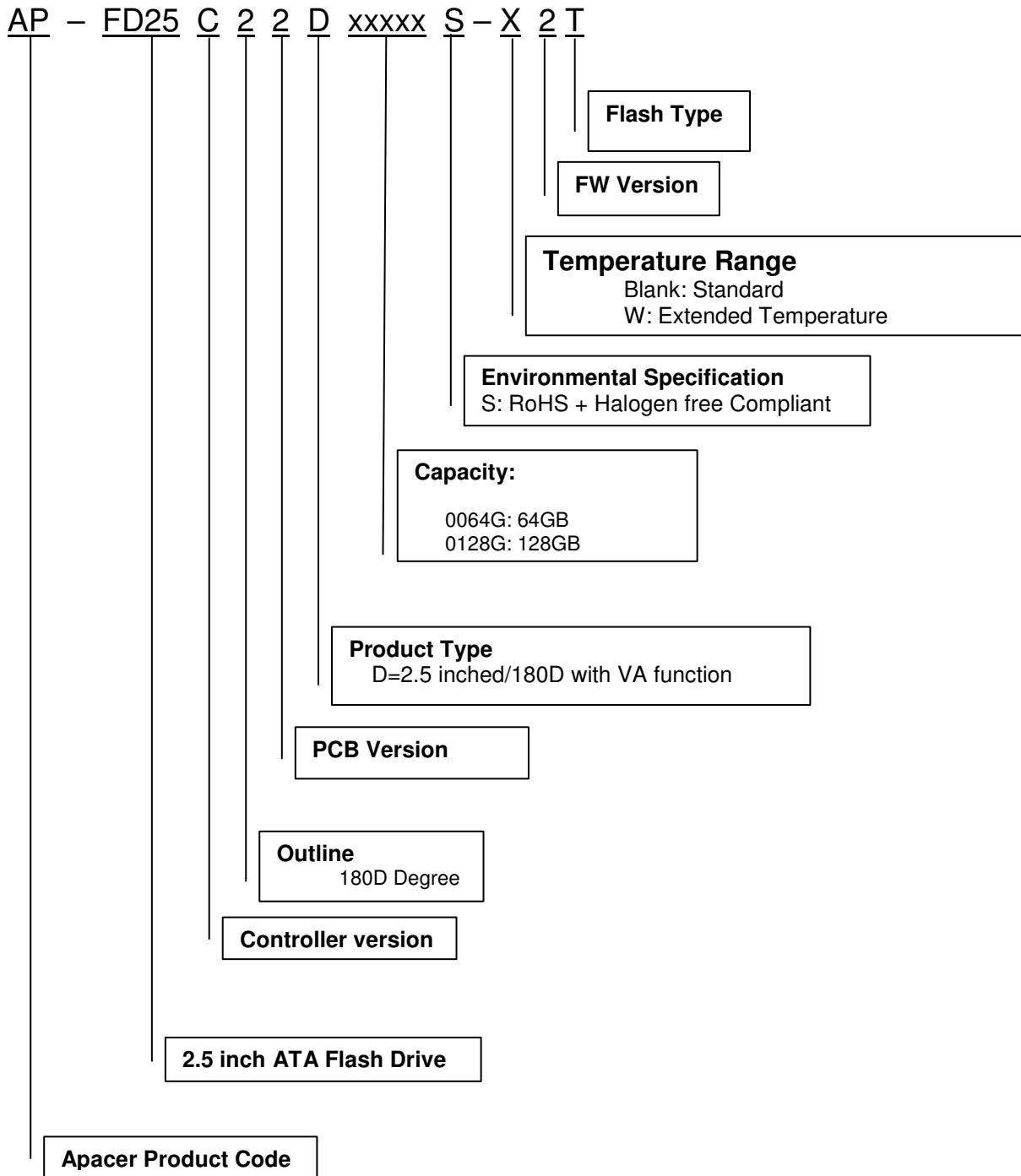

ATA Flash Drive 257

AP-FD25C22DxxxxxS-X2T



10.2 Valid Combinations

10.2.1 VA Function

Capacity	Model Number
64GB	AP-FD25C22D0064GS-2T
128GB	AP-FD25C22D0128GS-2T

10.2.2 VA Function ET

Capacity	Model Number
64GB	AP-FD25C22D0064GS-W2T
128GB	AP-FD25C22D0128GS-W2T

Note: Please consult with Apacer sales representatives for availabilities.

Revision History

Revision	Date	Description	Remark
1.0	01/24/2014	Official release	

Global Presence

Taiwan (Headquarters)	Apacer Technology Inc. 1F., No.32, Zhongcheng Rd., Tucheng Dist., New Taipei City 236, Taiwan R.O.C. Tel: 886-2-2267-8000 Fax: 886-2-2267-2261 amtsales@apacer.com
U.S.A.	Apacer Memory America, Inc. 386 Fairview Way, Suite102, Milpitas, CA 95035 Tel: 1-408-518-8699 Fax: 1-408-935-9611 sa@apacerus.com
Japan	Apacer Technology Corp. 5F, Matsura Bldg., Shiba, Minato-Ku Tokyo, 105-0014, Japan Tel: 81-3-5419-2668 Fax: 81-3-5419-0018 jpservices@apacer.com
Europe	Apacer Technology B.V. Science Park Eindhoven 5051 5692 EB Son, The Netherlands Tel: 31-40-267-0000 Fax: 31-40-267-0000#6199 sales@apacer.nl
China	Apacer Electronic (Shanghai) Co., Ltd 1301, No.251,Xiaomujiao Road, Shanghai, 200032, China Tel: 86-21-5529-0222 Fax: 86-21-5206-6939 sales@apacer.com.cn
India	Apacer Technologies Pvt Ltd, # 535, 1st Floor, 8th cross, JP Nagar 3rd Phase, Bangalore – 560078, India Tel: 91-80-4152-9061 sales_india@apacer.com