

RoHS Compliant

PCI Express Flash Drive

Industrial PV93E-M2110 BiCS5 Product Specifications



May 22, 2024

Version 1.0



Apacer Technology Inc.

1F, No.32, Zhongcheng Rd., Tucheng Dist., New Taipei City, Taiwan, R.O.C

Tel: +886-2-2267-8000 Fax: +886-2-2267-2261

www.apacer.com

Specifications Overview:

- **PCIe Interface**
 - Compliant with PCI Express 4.0
 - Compliant with NVMe 1.4
 - Compatible with PCIe Gen4 x4 interface
- **Capacity**
 - 480, 960, 1920 GB
- **Performance¹**
 - Interface burst read/write: 8 GB/sec
 - Sequential R/W: Up to 7,335/6,475 MB/sec
 - Random R/W (4K): Up to 1,231K/1,083K IOPS
 - Sustained seq. R/W: Up to 6,635/3,280 MB/sec
 - Sustained rand. R/W: Up to 912K/47K IOPS
 - Random R/W latency: 65/77 μ s
 - Random R/W QoS: 0.10/0.34 ms
- **Flash Management**
 - Low-Density Parity-Check (LDPC) Code
 - Global Wear Leveling
 - Flash bad-block management
 - Flash Translation Layer: Page Mapping
 - S.M.A.R.T.
 - TRIM
 - Hyper Cache Technology
 - Over-provisioning
 - SMART Read Refresh™
- **DRAM Cache for Enhanced Random Performance**
- **NAND Flash Type: 3D TLC (BiCS5)**
- **Reliability**
 - MTBF: >3,000,000 hours
 - Data Retention: 10 years
 - Endurance
 - DWPD: >1
 - 480 GB: 1,153 TBW
 - 960 GB: 2,290 TBW
 - 1920 GB: 4,651 TBW
- **Temperature Range**
 - Operating (Tc): 0°C to 70°C
 - Storage (Ta): -55°C to 100°C
- **Supply Voltage**
 - 3.3V \pm 5%
- **Power Consumption¹**
 - Active mode: 9.45 W
 - Idle mode: 1.95 W
 - Inrush current: 2.6 A
- **Enterprise Features**
 - AES 256-bit hardware encryption
 - Signed Firmware
 - CorePower
 - Thermal Sensor
 - Thermal Throttling
 - End-to-End Data Protection
 - Sidfill
 - Heat Spreader
- **Connector Type**
 - 75-pin M.2 module pinout
- **Physical Characteristics**
 - Form factor: Double-sided M.2 22110-M
 - Dimensions: 22.00 x 110.00 x 4.08_(max.), unit: mm
 - Net weight: 12.2g \pm 5%
- **RoHS Compliant**

Note:

1. Varies from capacities. The values for performances and power consumptions presented are typical and may vary depending on flash configurations or platform settings.

Table of Contents

1. General Description	4
2. Functional Block	5
3. Pin Assignments.....	6
4. Product Specifications.....	9
4.1 Capacity.....	9
4.2 Performance	9
4.3 Latency	10
4.4 Quality of Service (QoS).....	10
4.5 Environmental Specifications	10
4.6 Mean Time Between Failures (MTBF)	10
4.7 Certification and Compliance.....	11
4.8 Endurance	11
4.9 Data Retention.....	11
5. Flash Management.....	12
5.1 Error Correction/Detection.....	12
5.2 Bad Block Management	12
5.3 Global Wear Leveling	12
5.4 TRIM.....	12
5.5 Flash Translation Layer – Page Mapping.....	12
5.6 Hyper Cache Technology.....	13
5.7 Over-provisioning	13
5.8 SMART Read Refresh™	13
6. Enterprise Features	14
6.1 Advanced Encryption Standard.....	14
6.2 Signed Firmware	14
6.3 CorePower.....	14
6.4 Thermal Sensor	14
6.5 Thermal Throttling	15
6.6 End-to-End Data Protection.....	15
6.7 Sidefill	15
6.8 Heat Spreader	15

7. Software Interface	16
7.1 Command Set.....	16
7.2 S.M.A.R.T.	17
8. Electrical Specifications.....	19
8.1 Operating Voltage.....	19
8.2 Power Consumption	19
8.3 Inrush Current.....	19
9. Mechanical Specifications.....	20
10. Product Ordering Information.....	22
10.1 Product Code Designations.....	22
10.2 Valid Combinations.....	22

1. General Description

Apacer PV93E-M2110 is a high-performance and high endurance NVMe SSD designed as the standard M.2 form factor utilizing 112-layer 3D TLC NAND Flash. PV93E-M2110 supports PCIe Gen4 x4 interface and provides full compliance with NVMe 1.4 specifications, allowing the PCIe SSD to operate more effectively than SATA SSDs and greatly save on power consumption. PV93E-M2110 delivers outstanding, stable performance up to 7,335 MB/s for sequential read and 6,475 MB/s for sequential write and ultra-low latency with optimized QoS. PV93E-M2110 also presents better energy efficiency than traditional hard drives, extended endurance of more than 1 drive writes per day for 5 years and all the advantages of NAND Flash management technologies to ensure data integrity and highest levels of reliability, making it particularly suited for read-intensive, mixed-use workload applications.

PV93E-M2110 features enterprise-class reliability features implemented on both hardware and firmware levels. On the hardware level, PV93E-M2110 is not only built with a powerful PCIe controller that supports on-the-module ECC as well as LDPC (Low Density Parity Check) ECC engine to extend SSD endurance and increase data reliability, but also designed with graphene heat spreader to help keep an SSD cool and functioning correctly, while still allowing the drive to deliver high-speed performance. With the support of CorePower, PV93E-M2110 ensures data integrity and stability of data transmission in the event of unexpected power loss. This is achieved by implementing a backup power supply with tantalum capacitors, which provide sufficient time to transfer all cached data to NAND flash. To increase product reliability and resistance to various thermal and mechanical shocks, PV93E-M2110 also provides Sidefill technology to ensure that products continue to operate normally in high vibration and under extreme environmental changes.

On the firmware level, PV93E-M2110 is designed with an error-checking mechanism called End-to-End Data Protection to ensure all data in transit is protected against transient errors. To maintain consistent performance in the process of data transmission, PV93E-M2110 is configured with thermal throttling technology coupled with built-in thermal sensor to monitor the temperature of the SSD via S.M.A.R.T health monitoring and dynamically adjust frequency scaling to enhance data reliability and provide sustained performance while overheating.

In addition to data reliability, PV93E-M2110 also incorporates a variety of cutting-edge technologies featuring multiple approaches to data protection and security. PV93E-M2110 comes with not only AES to provide highly secure hardware encryption, but also Signed Firmware to allow firmware to be updated in a secure way with a digital signature. To add an additional level of protection, PV93E-M2110 supports SMART Read Refresh, developed particularly for read-intensive applications, to avoid read disturb errors from occurring to ensure health status of all blocks of NAND flash.

Apacer PV93E-M2110 is an enterprise-class SSD designed for server applications that require consistent performance, low latency and continuous large file transfers for 24/7 uptime and reliability. With superior performance, instant responsiveness, advanced power loss protection technology and highest standard of reliability – whether in terms of data security, data integrity and data protection, Apacer PV93E-M2110 is an ideal solution for enterprise servers, data centers and cloud service providers.

2. Functional Block

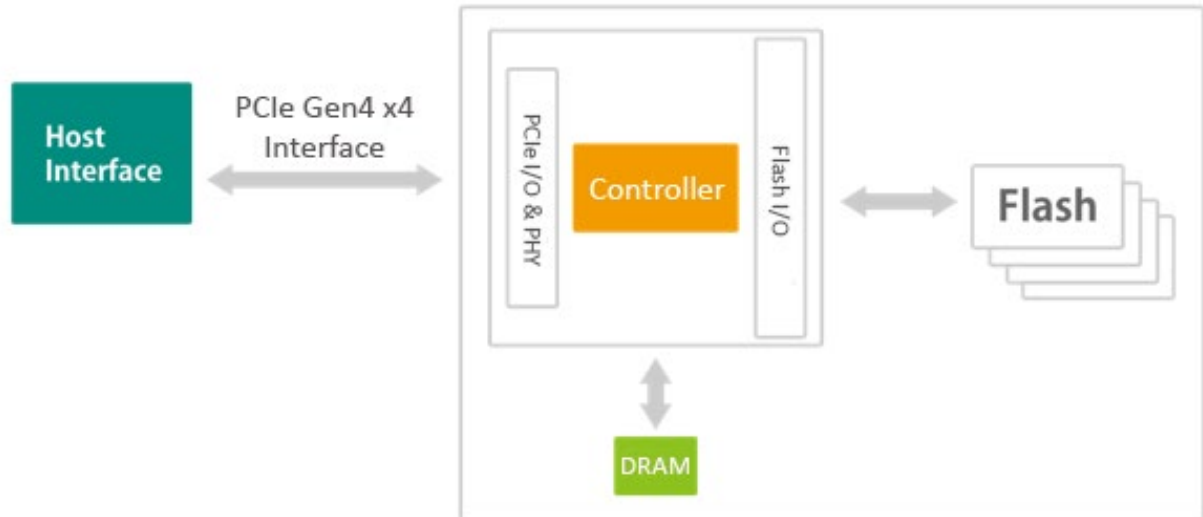

Note: The actual number of NAND flash used on Apacer PV93E-M2110 varies from capacities. The illustration is for reference only.

Figure 2-1 Functional Block Diagram

3. Pin Assignments

This connector does not support hot plug capability. There are a total of 75 pins. 12 pin locations are used for mechanical key locations; this allows such a module to plug into Key M connectors.

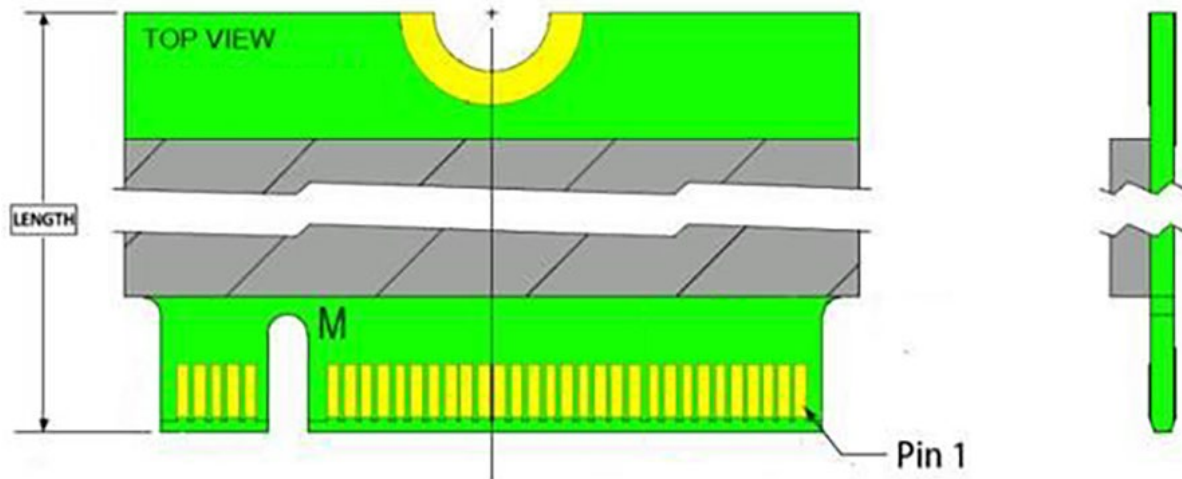

Figure 3-1 Pin Connectors

Table 3-1 Pin Assignments

Pin No.	Type	Description
1	GND	Ground
2	3.3 V	3.3V source
3	GND	Ground
4	3.3 V	3.3V source
5	PETn3	PCIe TX Differential signal defined by the PCI Express M.2 spec
6	PWRDIS (I)(0/1.8/3.3V)	No connect
7	PETp3	PCIe TX Differential signal defined by the PCI Express M.2 spec
8	PLN# (I)(0/1.8/3.3V)	No connect
9	GND	Ground
10	LED1#	Open drain, active low signal. These signals are used to allow the add-in card to provide status indicators via LED devices that will be provided by the system.
11	PERn3	PCIe RX Differential signal defined by the PCI Express M.2 spec
12	3.3 V	3.3V source
13	PERp3	PCIe RX Differential signals defined by the PCI Express M.2 spec
14	3.3 V	3.3V source
15	GND	Ground
16	3.3 V	3.3V source
17	PETn2	PCIe TX Differential signal defined by the PCI Express M.2 spec
18	3.3 V	3.3V source
19	PETp2	PCIe TX Differential signal defined by the PCI Express M.2 spec

Table 3-1 Pin Assignments

Pin No.	Type	Description
20	NC	No connect
21	GND	Ground
22	NC	No connect
23	PERn2	PCIe RX Differential signal defined by the PCI Express M.2 spec
24	NC	No connect
25	PERp2	PCIe RX Differential signal defined by the PCI Express M.2 spec
26	NC	No connect
27	GND	Ground
28	NC	No connect
29	PETn1	PCIe TX Differential signal defined by the PCI Express M.2 spec
30	PLA_S3# (O)(0/1.8/3.3V)	No connect
31	PETp1	PCIe TX Differential signal defined by the PCI Express M.2 spec
32	NC	No connect
33	GND	Ground
34	USB_D+	No connect
35	PERn1	PCIe RX Differential signal defined by the PCI Express M.2 spec
36	USB_D-	No connect
37	PERp1	PCIe RX Differential signal defined by the PCI Express M.2 spec
38	NC	No connect
39	GND	Ground
40	SMB_CLK (I/O)(0/1.8V)	No connect
41	PETn0	PCIe TX Differential signal defined by the PCI Express M.2 spec
42	SMB_DATA (I/O)(0/1.8V)	No connect
43	PETp0	PCIe TX Differential signal defined by the PCI Express M.2 spec
44	ALERT# (O)(0/1.8V)	No connect
45	GND	Ground
46	NC	No connect
47	PERn0	PCIe RX Differential signal defined by the PCI Express M.2 spec
48	NC	No connect
49	PERp0	PCIe RX Differential signal defined by the PCI Express M.2 spec
50	PERST# (I)(0/1.8V/3.3V)	PE-Reset is a functional reset to the card as specification. defined by the PCIe Mini CEM
51	GND	Ground
52	CLKREQ# (I/O)(0/1.8V/3.3V)	Clock Request is a reference clock request signal as defined by the PCIe Mini CEM specification; Also used by L1 PM Substates.
53	REFCLKn	PCIe Reference Clock signals (100 MHz) spec. defined by the PCI Express M.2
54	PEWAKE# (I/O)(0/1.8V/3.3V)	No connect
55	REFCLKp	PCIe Reference Clock signals (100 MHz) spec. defined by the PCI Express M.2
56	Reserved for MFG_DATA	Reserved for Apacer use only ¹
57	GND	Ground
58	Reserved for MFG_CLOCK	Reserved for Apacer use only ¹

Table 3-1 Pin Assignments

Pin No.	Type	Description
59	Module Key M	Module Key
60	Module Key M	Module Key
61	Module Key M	Module Key
62	Module Key M	Module Key
63	Module Key M	Module Key
64	Module Key M	Module Key
65	Module Key M	Module Key
66	Module Key M	Module Key
67	NC	No connect
68	SUSCLK (I)(0/1.8V/3.3V)	No connect
69	PEDET	No connect
70	3.3 V	3.3V source
71	GND	Ground
72	3.3 V	3.3V source
73	VIO_CFG (O)	Ground
74	3.3 V	3.3V source
75	GND	Ground

Note:

1. Reserved by Apacer, please do not connect to a host.

4. Product Specifications

4.1 Capacity

Capacity specifications of PV93E-M2110 are available as shown in Table 4-1.

Table 4-1 Capacity Specifications

Capacity	Total bytes	Total LBA
480 GB	480,103,981,056	937,703,088
960 GB	960,197,124,096	1,875,385,008
1920 GB	1,920,383,410,176	3,750,748,848

Notes:

- Display of total bytes varies from operating systems.
- 1 GB = 1,000,000,000 bytes; 1 sector = 512 bytes.
- LBA count addressed in the table above indicates total user storage capacity and will remain the same throughout the lifespan of the device. However, the total usable capacity of the SSD is most likely to be less than the total physical capacity because a small portion of the capacity is reserved for device maintenance usages.

4.2 Performance

Performance of PV93E-M2110 is listed below in Table 4-2 and 4-3.

Table 4-2 Performance

Performance	Unit	480 GB	960 GB	1920 GB
Sequential Read	MB/s	5,465	4,930	7,335
Sequential Write		1,765	3,060	6,475
4K Random Read	IOPS	435,000	828,000	1,231,000
4K Random Write		432,000	732,000	1,083,000

Notes:

- Results may differ from various flash configurations or host system setting.
- Sequential read/write is based on CrystalDiskMark 8.0.4 with file size 1,000MB.
- Random read/write is measured using IOMeter with Queue Depth 128.

Table 4-3 Sustained Performance

Performance	Unit	480 GB	960 GB	1920 GB
Sequential Read	MB/s	3,860	4,980	6,635
Sequential Write		850	1,760	3,280
4K Random Read	IOPS	281,000	541,000	912,000
4K Random Write		9,000	29,000	47,000

Notes:

- Sustained sequential read/write is measured by using FIO with 128KB and 1024KB of data transfer size in Queue Depth 32 by 1 worker.
- Sustained random read/write is measured by using FIO with 4KB of data transfer size in Queue Depth 32 by 16 worker.

4.3 Latency

Table 4-4 Latency

Performance	Unit	480 GB	960 GB	1920 GB
Random Read	μs	65	64	65
Random Write		77	27	15

Note: Latency is measured by using the SNIA SSS (Solid State Storage) PTS (Performance Test Specification) with 4KB data transfer size in Queue Depth 1 by 1 worker.

4.4 Quality of Service (QoS)

Table 4-5 Quality of Service (QoS)

Quality of Service (99.9%)	Unit	480 GB	960 GB	1920 GB
Random Read	ms	0.10	0.09	0.10
Random Write		0.34	0.03	0.16

Notes:

- QoS is measured by using StorScore with Queue Depth 1 on 4KB random read and write.
- QoS is measured as the round-trip time taken for 99.9% of commands to host.

4.5 Environmental Specifications

Environmental specifications of PV93E-M2110 are shown in Table 4-6.

Table 4-6 Environmental Specifications

Parameter	Type	Specifications
Temperature	Operating (Tc)	0°C to 70°C
	Non-operating (Ta)	-55°C to 100°C
Vibration	Operating	7.69 GRMS, 20~2000 Hz/random (compliant with MIL-STD-810G)
	Non-operating	4.02 GRMS, 15~2000 Hz/random (compliant with MIL-STD-810G)
Shock	Operating	Acceleration, 50(G)/11(ms)/half sine (compliant with MIL-STD-202G)
	Non-operating	Acceleration, 1500(G)/0.5(ms)/half sine (compliant with MIL-STD-883K)

Notes:

- This Environmental Specification table indicates the conditions for testing the device. Real world usages may affect the results.
- Tc: case temperature; Ta: ambient temperature. The operating temperature is determined by the case temperature. Adequate airflow is advisable as it enables the device to maintain optimal temperatures, especially in environments with heavy workloads.

4.6 Mean Time Between Failures (MTBF)

Mean Time Between Failures (MTBF) is predicted based on reliability data for the individual components in PV93E-M2110. The prediction result for PV93E-M2110 is more than 3,000,000 hours.

Note: The MTBF is predicated and calculated based on “Telcordia Technologies Special Report, SR-332, Issue 3” method.

4.7 Certification and Compliance

PV93E-M2110 complies with the following standards:

- CE
- UKCA
- FCC
- RoHS
- MIL-STD-810G

4.8 Endurance

The endurance of a storage device is predicted by TeraBytes Written and Drive Writes Per Day based on several factors related to usage, such as the amount of data written into the drive, block management conditions, and daily workload for the drive. Thus, key factors, such as Write Amplifications and the number of P/E cycles, can influence the lifespan of the drive.

Table 4-7 Endurance Specifications

Capacity	TeraBytes Written	Drive Writes Per Day
480 GB	1,153	1.35
960 GB	2,290	1.34
1920 GB	4,651	1.36

Notes:

- This estimation complies with JEDEC JESD-219, enterprise endurance workload of random data with payload size distribution.
- Flash vendor guaranteed 3D NAND TLC P/E cycles: 3K
- WAF may vary from capacity, flash configurations and writing behavior on each platform.
- 1 Terabyte = 1,024GB
- DWPD (Drive Writes Per Day) is calculated based on the number of times that user overwrites the entire capacity of an SSD per day of its lifetime during the warranty period. (3D NAND TLC warranty: 5 years)

4.9 Data Retention

Table 4-8 Data Retention

NAND Flash P/E Cycle	Value
100	10 years

Note: Data retention was evaluated at the temperature of 40°C.

5. Flash Management

5.1 Error Correction/Detection

PV93E-M2110 implements a hardware ECC scheme, based on the Low Density Parity Check (LDPC). LDPC is a class of linear block error correcting code which has apparent coding gain over BCH code because LDPC code includes both hard decoding and soft decoding algorithms. With the error rate decreasing, LDPC can extend SSD endurance and increase data reliability while reading raw data inside a flash chip.

5.2 Bad Block Management

Current production technology is unable to guarantee total reliability of NAND flash memory array. When a flash memory device leaves factory, it comes with a minimal number of initial bad blocks during production or out-of-factory as there is no currently known technology that produce flash chips free of bad blocks. In addition, bad blocks may develop during program/erase cycles. Since bad blocks are inevitable, the solution is to keep them in control. Apacer flash devices are programmed with ECC, page mapping technique and S.M.A.R.T to reduce invalidity or error. Once bad blocks are detected, data in those blocks will be transferred to free blocks and error will be corrected by designated algorithms.

5.3 Global Wear Leveling

Flash memory devices differ from Hard Disk Drives (HDDs) in terms of how blocks are utilized. For HDDs, when a change is made to stored data, like erase or update, the controller mechanism on HDDs will perform overwrites on blocks. Unlike HDDs, flash blocks cannot be overwritten and each P/E cycle wears down the lifespan of blocks gradually. Repeatedly program/erase cycles performed on the same memory cells will eventually cause some blocks to age faster than others. This would bring flash storages to their end of service term sooner. Global wear leveling is an important mechanism that levels out the wearing of all blocks so that the wearing-down of all blocks can be almost evenly distributed. This will increase the lifespan of SSDs.

5.4 TRIM

TRIM is a feature which helps improve the read/write performance and speed of solid-state drives (SSD). Unlike hard disk drives (HDD), SSDs are not able to overwrite existing data, so the available space gradually becomes smaller with each use. With the TRIM command, the operating system can inform the SSD which blocks of data are no longer in use and can be removed permanently. Thus, the SSD will perform the erase action, which prevents unused data from occupying blocks all the time.

5.5 Flash Translation Layer – Page Mapping

Page mapping is an advanced flash management technology whose essence lies in the ability to gather data, distribute the data into flash pages automatically, and then schedule the data to be evenly written. Page-level mapping uses one page as the unit of mapping. The most important characteristic is that each logical page can be mapped to any physical page on the flash memory device. This mapping algorithm allows different sizes of data to be written to a block as if the data is written to a data pool and it does not need to take extra operations to process a write command. Thus, page mapping is adopted to increase random access speed and improve SSD lifespan, reduce block erase frequency, and achieve optimized performance and lifespan.

5.6 Hyper Cache Technology

Apacer proprietary Hyper Cache technology uses a portion of the available capacity as SLC (1bit-per-cell) NAND flash memory, called Hyper cache mode. When data is written to SSD, the firmware will direct the data to Hyper Cache mode, providing excellent performance to handle various scenarios in industrial use.

5.7 Over-provisioning

Over-provisioning (OP) is a certain portion of the SSD capacity exclusively for increasing Garbage Collection (GC) efficiency, especially when the SSD is filled to full capacity or performs a heavy mixed-random workload. OP has the advantages of providing extended life expectancy, reliable data integrity, and high sustained write performance.

5.8 SMART Read Refresh™

Apacer's SMART Read Refresh plays a proactive role in avoiding read disturb errors from occurring to ensure health status of all blocks of NAND flash. Developed for read-intensive applications in particular, SMART Read Refresh is employed to make sure that during read operations, when the read operation threshold is reached, the data is refreshed by re-writing it to a different block for subsequent use.

6. Enterprise Features

6.1 Advanced Encryption Standard

Advanced Encryption Standard (AES) is a specification for the encryption of electronic data. AES has been adopted by the U.S. government since 2001 to protect classified information and is now widely implemented in embedded computing applications. The AES algorithm used in software and hardware is symmetric so that encrypting/decrypting requires the same encryption key. Without the key, the encrypted data is inaccessible to ensure information security.

Notably in flash memory applications, AES 256-bit hardware encryption is the mainstream to protect sensitive or confidential data. The hardware encryption provides better performance, reliability, and security than software encryption. It uses a dedicated processor, which is built inside the controller, to process the encryption and decryption. This enormously shortens the processing time and makes it efficient.

6.2 Signed Firmware

Apacer's Signed Firmware technology is a secure way to update firmware. By including a digital signature, a firmware update will be authenticated by the Apacer SSD before a firmware update is performed. This extra layer of protection keeps drives secure.

6.3 CorePower

If the voltage supply is cut, for instance, accidental power off or sudden blackout, the data would be shortly lost. To protect SSD data integrity from this disastrous scenario, Apacer has developed the hardware-based technology named Apacer CorePower. The CorePower equips SSDs with tantalum capacitors that can deliver urgent power current so that the flash controller can take this extended moment to flush cached data and essential metadata into NAND Flash blocks.

In addition to tantalum capacitors which guarantee SSD data integrity, an inbuilt IC detector also serves the same purpose as well as ensures the stability of data transmission. The detector is designed to take proactive measures for the aforementioned disastrous scenario. When supply voltage drops below a minimum threshold, the detector will send out signals to the flash controller notifying it to stop operating to prevent poor performance or erratic operation. In the meanwhile, signals will also be sent to DRAM (OR internal write cache (SRAM)) to have cached data flushed into NAND Flash blocks so as to avoid data loss, similar to the function performed by tantalum capacitors.

PV93E-M2110 is equipped with tantalum capacitors which have lower power leakage, higher operating temperature and higher volume-efficiency (high capacitance in small volume) than many other types of capacitors. The compact size and the high reliability are ideal for embedded computing systems.

6.4 Thermal Sensor

Apacer Thermal Sensor is a digital temperature sensor with serial interface. By using designated pins for transmission, storage device owners are able to read temperature data.

6.5 Thermal Throttling

Thermal throttling can monitor the temperature of the SSD equipped with a built-in thermal sensor via S.M.A.R.T. commands. This method can ensure the temperature of the device stays within temperature limits by drive throttling, i.e. reducing the speed of the drive when the device temperature reaches the threshold level, so as to prevent overheating, guarantee data reliability, and prolong product lifespan. When the temperature exceeds the maximum threshold level, thermal throttling will be triggered to reduce performance step by step to prevent hardware components from being damaged. Performance is only permitted to drop to the extent necessary for recovering a stable temperature to cool down the device's temperature. Once the temperature decreases to the minimum threshold value, transfer speeds will rise back to its optimum performance level.

6.6 End-to-End Data Protection

End-to-End Data Protection is a feature implemented in Apacer SSD products that extends error control to cover the entire path from the host computer to the drive and back, and that ensures data integrity at multiple points in the path to enable reliable delivery of data transfers. Unlike ECC which does not exhibit the ability to determine the occurrence of errors throughout the process of data transmission, End-to-End Data Protection allows SSD controller to identify an error created anywhere in the path and report the error to the host computer before it is written to the drive. This error-checking and error-reporting mechanism therefore guarantees the trustworthiness and reliability of the SSD.

6.7 Sidefill

Apacer's sidefill technology strengthens the connections between solder joints and their board, making them more robust and vibration-resistant. It also allows for heat dissipation to offset thermal damage.

6.8 Heat Spreader

In many applications, SSDs are subject to challenging conditions. If the working environment is already hot, and the SSD's operation causes it to increase in temperature as well, the result could be damage to the hardware or corrupted data. For this reason, Apacer's graphene heat spreader is developed for heat dissipation to cool both the NAND Flash and the Controller IC, while still allowing an SSD to deliver high-speed performance, as well as prevent heat-related damage from occurring.

7. Software Interface

7.1 Command Set

Table 7-1 summarizes the commands supported by PV93E-M2110.

Table 7-1 Admin Commands

Opcode	Command Description
00h	Delete I/O Submission Queue
01h	Create I/O Submission Queue
02h	Get Log Page
04h	Delete I/O Completion Queue
05h	Create I/O Completion Queue
06h	Identify
08h	Abort
09h	Set Features
0Ah	Get Features
0Ch	Asynchronous Event Request
10h	Firmware Activate
11h	Firmware Image Download

Table 7-2 Admin Commands – NVM Command Set Specific

Opcode	Command Description
80h	Format NVM
84h	Sanitize

Table 7-3 NVM Commands

Opcode	Command Description
00h	Flush
01h	Write
02h	Read
09h	Dataset Management

7.2 S.M.A.R.T.

SMART, an acronym for Self-Monitoring, Analysis and Reporting Technology, is an open standard that allows a hard disk drive to automatically detect its health and report potential failures. When a failure is recorded by SMART, users can choose to replace the drive to prevent unexpected outage or data loss. Moreover, SMART can inform users of impending failures while there is still time to perform proactive actions, such as copy data to another device.

Table 7-4 SMART (02h)

Byte	Length	Description
0	1	Critical Warning
1-2	2	Composite Temperature
3	1	Available Spare
4	1	Available Spare Threshold
5	1	Percentage Used (Average Erase Count / P/E Cycle Count)
6-31	26	Reserved
32-47	16	Data Units Read
48-63	16	Data Units Written
64-79	16	Host Read Commands
80-95	16	Host Write Commands
96-111	16	Controller Busy Time
112-127	16	Power Cycles
128-143	16	Power On Hours
144-159	16	Unsafe Shutdowns
160-175	16	Media and Data Integrity Errors
176-191	16	Number of Error Information Log Entries
192-195	4	Warning Composite Temperature Time
196-199	4	Critical Composite Temperature Time
200-201	2	Temperature Sensor 1: Controller Temperature
202-203	2	Temperature Sensor 2: PCB Temperature
204-205	2	Temperature Sensor 3: NAND Flash Temperature
206-207	2	Temperature Sensor 4
208-209	2	Temperature Sensor 5
210-211	2	Temperature Sensor 6
212-213	2	Temperature Sensor 7
214-215	2	Temperature Sensor 8
216-511	296	Reserved

Note: Temperature display of the Temperature Sensor from 1 to 8 (corresponding bytes from 200 to 215) is not supported if the return value is 0h.

Table 7-5 SMART (C0h)

Byte	Length	Description
0-255	256	Reserved
256-257	2	SSD Protect Mode
258-261	4	Host Read UNC Count
262-265	4	PHY Error Count
266-269	4	CRC Error Count
270-273	4	Total Early Bad Block Count
274-277	4	Total Later Bad Block Count
278-281	4	Max Erase Count
282-285	4	Average Erase Count
286-289	4	Program Fail Count
290-293	4	Erase Fail Count
294-301	8	Flash Write Sector
302-305	4	Total Spare Block
306-309	4	Current Spare Block
310-313	4	Read Retry Count
314-511	210	Reserved

8. Electrical Specifications

8.1 Operating Voltage

Table 8-1 lists the supply voltage for PV93E-M2110.

Table 8-1 Operating Range

Item	Range
Supply Voltage	3.3V ± 5%

8.2 Power Consumption

Table 8-2 lists the power consumption for PV93E-M2110.

Table 8-2 Power Consumption

Mode	Unit	480 GB	960 GB	1920 GB
Read	W	5.53	5.53	7.43
Write		3.84	5.68	9.45
Idle		1.90	1.93	1.95

Notes:

- All values are typical and may vary depending on flash configurations or host system settings.
- Power consumption is measured using CrystalDiskMark 8.0.4 with file size 1,000MB.

8.3 Inrush Current

Table 8-3 Inrush Current

Inrush Current	480 GB	960 GB	1920 GB
3.3V	2.6 A		

9. Mechanical Specifications

Table 9-1 Physical Information

Parameter	Unit	480 GB	960 GB	1920 GB
Length	mm	110.00 ± 0.15		
Width		22.00 ± 0.15		
Height (Max.)		4.08		
Weight	g ± 5%	12.00	12.07	12.20

Top View

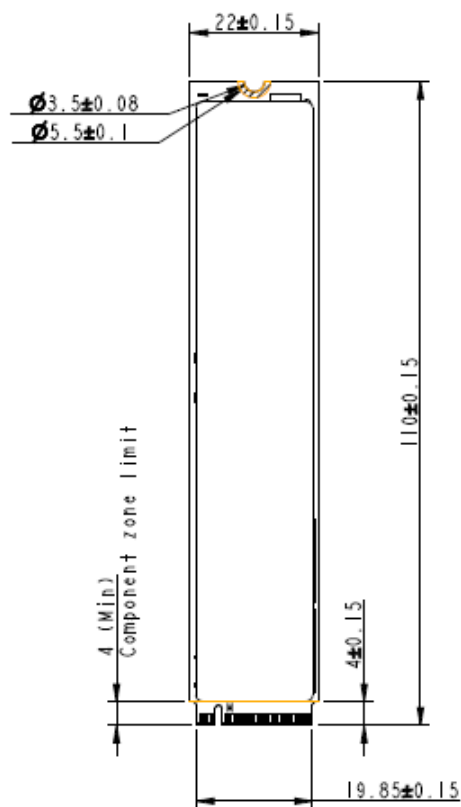

Side View

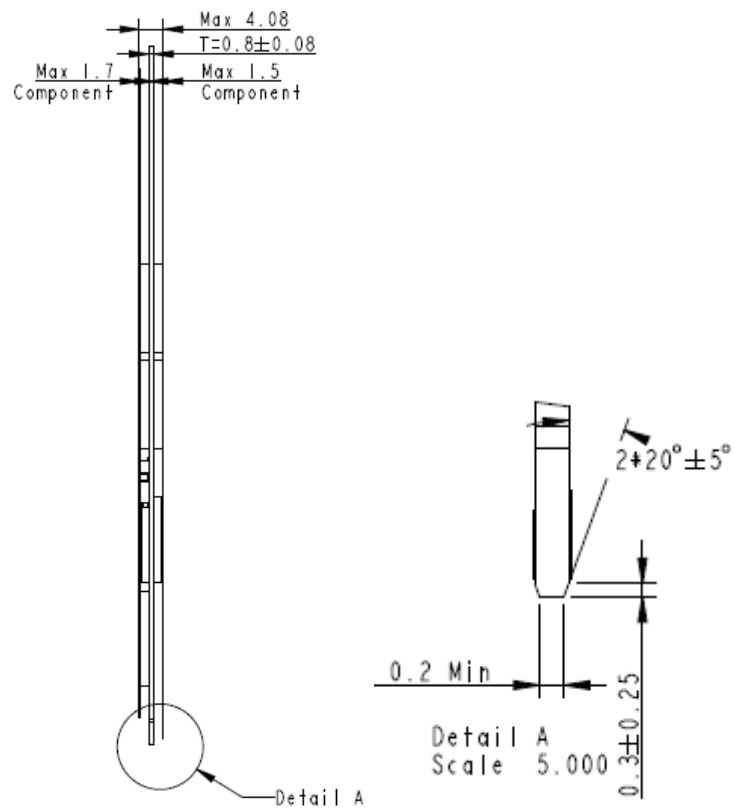

Bottom View

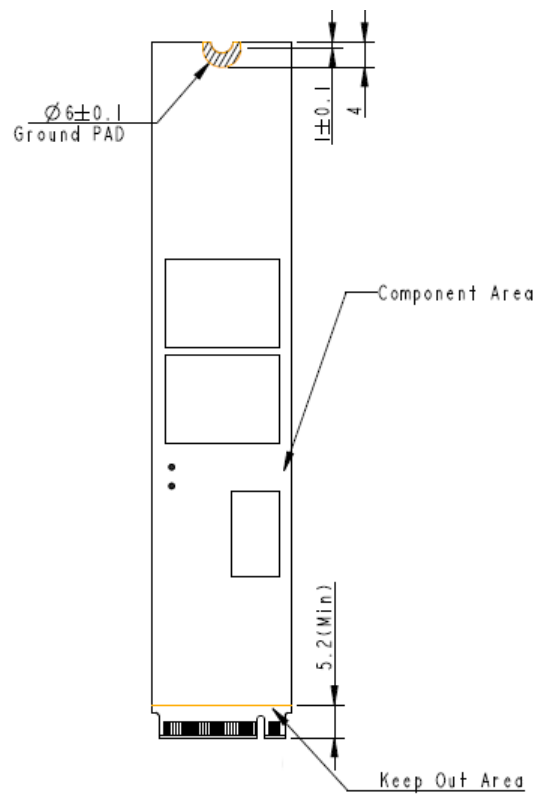

Figure 9-1 Physical Dimensions

10. Product Ordering Information

10.1 Product Code Designations

Apacer's PV93E-M2110 SSD is available in different configurations and densities. See the chart below for a comprehensive list of options for the PV93E-M2110 series devices.

Code	1	2	3	4	5	6	7	8	9	10	11	12	13	14	15	16
	B	A	2	.	P	2	5	X	G	U	.	0	0	3	0	8

Code 1-3 (Product Line & Form Factor)	PCIe M.2 22110
Code 5-6 (Model/Solution)	PV93E
Code 7-8 (Product Capacity)	5K: 480GB 5L: 960GB 5M: 1920GB
Code 9 (Flash Type & Product Temp)	3D TLC Standard Temperature
Code 10 (Product Spec)	Double-sided M key with graphene
Code 12-14 (Version Number)	Random numbers generated by system
Code 15-16 (Firmware Version)	Thermal Sensor PLP OP

10.2 Valid Combinations

The following table lists the available models of the PV93E-M2110 series which are in mass production or will be in mass production. Consult your Apacer sales representative to confirm availability of valid combinations and to determine availability of new combinations.

Capacity	Valid Combination
480GB	BA2.P25KGU.00308
960GB	BA2.P25LGU.00308
1920GB	BA2.P25MGU.00308

Revision History

Revision	Description	Date
1.0	Initial release	5/22/2024

Global Presence

Taiwan (Headquarters)

Apacer Technology Inc.

1F., No.32, Zhongcheng Rd., Tucheng Dist.,
New Taipei City 236, Taiwan R.O.C.
Tel: 886-2-2267-8000
Fax: 886-2-2267-2261
amtsales@apacer.com

U.S.A.

Apacer Memory America, Inc.

46732 Lakeview Blvd., Fremont, CA 94538
Tel: 1-408-518-8699
Fax: 1-510-249-9551
sa@apacerus.com

Japan

Apacer Technology Corp.

6F, Daiyontamachi Bldg., 2-17-12, Shibaura, Minato-Ku,
Tokyo, 108-0023, Japan
Tel: 81-3-5419-2668
Fax: 81-3-5419-0018
jpservices@apacer.com

Europe

Apacer Technology B.V.

Science Park Eindhoven 5051 5692 EB Son,
The Netherlands
Tel: 31-40-267-0000
Fax: 31-40-290-0686
sales@apacer.nl

China

Apacer Electronic (Shanghai) Co., Ltd

Room D, 22/FL, No.2, Lane 600, JieyunPlaza,
Tianshan RD, Shanghai, 200051, China
Tel: 86-21-6228-9939
Fax: 86-21-6228-9936
sales@apacer.com.cn

India

Apacer Technologies Pvt Ltd,

1874, South End C Cross, 9th Block Jayanagar,
Bangalore-560069, India
Tel: 91-80-4152-9061/62
Fax: 91-80-4170-0215
sales_india@apacer.com