

RoHS Recast Compliant

## Industrial microSD 3.0

MicroSDHC H1-M Product Specifications

(Toshiba 15nm)

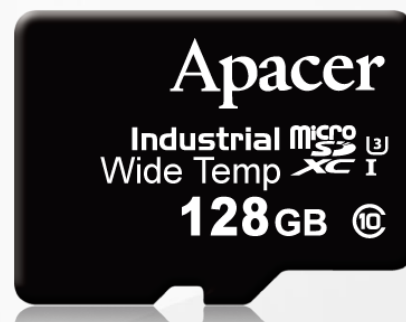

October 16, 2020

Version 2.5



**Apacer Technology Inc.**

1F, No.32, Zhongcheng Rd., Tucheng Dist., New Taipei City, Taiwan, R.O.C

Tel: +886-2-2267-8000 Fax: +886-2-2267-2261

[www.apacer.com](http://www.apacer.com)

## Specifications Overview:

- **Fully Compatible with SD Card Association Specifications**
  - Part 1, Physical Layer Specification, Ver 3.01 Final
  - Part 2, File System Specifications, Ver 3.00
  - Part 3, Security Specifications, Ver 3.00 Final
- **Capacity**
  - 4, 8, 16, 32, 64, 128 GB
- **Performance\***
  - Sequential read: Up to 90 MB/sec
  - Sequential write: Up to 75 MB/sec
- **Flash Management**
  - Built-in advanced ECC algorithm
  - Global Wear Leveling
  - Flash bad-block management
  - S.M.A.R.T.
  - Power Failure Management
  - SMART Read Refresh™
- **NAND Flash Type: MLC**
- **SD-Protocol Compatible**
- **Supports SD SPI Mode**
- **Backward Compatible with 2.0**
- **Temperature Range**
  - Operating:
    - Standard: -25°C to 85°C
    - Wide: -40°C to 85°C
  - Storage: -40°C to 85°C
- **Operating Voltage: 2.7V ~ 3.6V**
- **Power Consumption\***
  - Operating: 180 mA
  - Standby: 475 µA
- **Bus Speed Mode: Support Class 10 with UHS-I\*\***
  - DS: Default Speed up to 25MHz 3.3V signaling
  - HS: High Speed up to 50MHz 3.3V signaling
  - SDR12: SDR up to 25MHz 1.8V signaling
  - SDR25: SDR up to 50MHz 1.8V signaling
  - SDR50: SDR up to 100MHz 1.8V signaling
  - SDR104: SDR up to 208MHz 1.8V signaling
  - DDR50: DDR up to 50MHz 1.8V signaling
- **Physical Dimensions:**
  - 15mm (L) x 11mm (W) x 1mm (H)
- **RoHS Recast Compliant**

\*Performance values presented here are typical and measured based on USB 3.0 card reader. The results may vary depending on settings and platforms.

\*\*Timing in 1.8V signaling is different from that of 3.3V signaling. Operation mode selection command is compliant with SD 3.0, referring to SDA's Part 1, Physical Layer Specification, Ver 3.01 (Section 3.9)

## Table of Contents

<b>1. General Descriptions .....</b>	<b>4</b>
1.1 Functional Block.....	4
1.2 Flash Management .....	5
1.2.1 Bad Block Management.....	5
1.2.2 Powerful ECC Algorithms .....	5
1.2.3 Global Wear Leveling .....	5
1.2.4 S.M.A.R.T. ....	5
1.2.5 Power Failure Management.....	5
1.2.6 SMART Read Refresh™.....	5
<b>2. Product Specifications.....</b>	<b>6</b>
2.1 Card Architecture .....	6
2.2 Pin Assignment .....	6
2.3 Capacity.....	7
2.4 Performance.....	7
2.5 Electrical.....	7
<b>3. Physical Characteristics.....</b>	<b>8</b>
3.1 Physical Dimensions.....	8
3.2 Durability Specifications.....	10
<b>4. AC Characteristics .....</b>	<b>11</b>
4.1 MicroSD Interface Timing (Default) .....	11
4.2 MicroSD Interface Timing (High Speed Mode) .....	12
4.3 MicroSD Interface Timing (SDR12, SDR25, SDR50 and SDR104 Modes) .....	14
4.3.1 Clock Timing .....	14
4.3.2 Card Input Timing .....	14
4.3.3 Card Output Timing of Fixed Data Window (SDR12, SDR25 and SDR50) .....	15
4.3.4 Output Timing of Variable Window (SDR104) .....	15
4.3.5 SD Interface Timing (DDR50 Mode).....	16
4.3.6 Bus Timings – Parameters Values (DDR50 Mode).....	17
<b>5. S.M.A.R.T. ....</b>	<b>18</b>
5.1 Direct Host Access to SMART Data via SD General Command (CMD56).....	18
5.2 Process for Retrieving SMART Data .....	18
<b>6. Product Ordering Information.....</b>	<b>21</b>

6.1 Product Code Designations .....	21
6.2 Valid Combinations .....	22

# 1. General Descriptions

The Micro Secure Digital (MicroSD) card version 3.0 is fully compliant to the specification released by SD Card Association. The Command List supports [Part 1 Physical Layer Specification Ver3.01 Final] definitions. Card Capacity of Non-secure Area, Secure Area Supports [Part 3 Security Specification Ver3.00 Final] Specifications.

The MicroSD 3.0 card comes with 8-pin interface, designed to operate at optimal performance. It can alternate communication protocol between the SD mode and SPI mode. It performs data error detection and correction with very low power consumption.

Apacer Industrial Micro Secure Digital 3.0 card is ideal for its high performance, good reliability and wide compatibility. Not to mention that it's well adapted for hand-held applications in semi-industrial/medical markets already. The new MicroSD 3.0 card is capable of delivering better performance and P/E cycles.

## 1.1 Functional Block

The MicroSD contains a card controller and a memory core for the SD standard interface.

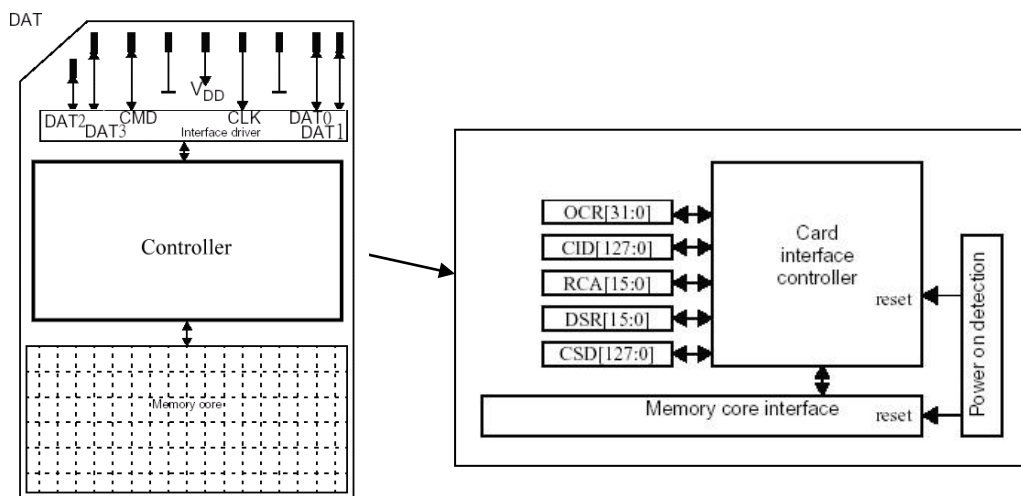

Figure 1-1 Functional Block Diagram

## 1.2 Flash Management

### 1.2.1 Bad Block Management

Bad blocks are blocks that include one or more invalid bits, and their reliability is not guaranteed. Blocks that are identified and marked as bad by the manufacturer are referred to as “Initial Bad Blocks”. Bad blocks that are developed during the lifespan of the flash are named “Later Bad Blocks”. Apacer implements an efficient bad block management algorithm to detect the factory-produced bad blocks and manages any bad blocks that appear with use. This practice further prevents data being stored into bad blocks and improves the data reliability.

### 1.2.2 Powerful ECC Algorithms

Flash memory cells will deteriorate with use, which might generate random bit errors in the stored data. Thus, the MicroSD card applies the BCH ECC Algorithm, which can detect and correct errors occur during read process, ensure data been read correctly, as well as protect data from corruption.

### 1.2.3 Global Wear Leveling

NAND Flash devices can only undergo a limited number of program/erase cycles, and in most cases, the flash media are not used evenly. If some area get updated more frequently than others, the lifetime of the device would be reduced significantly. Thus, Global Wear Leveling technique is applied to extend the lifespan of NAND Flash by evenly distributing writes and erase cycles across the media.

Apacer provides Global Wear Leveling algorithm, which can efficiently spread out the flash usage through the whole flash media area. Moreover, by implementing Global Wear Leveling algorithm, the life expectancy of the NAND Flash is greatly improved.

### 1.2.4 S.M.A.R.T.

SMART, an acronym for Self-Monitoring, Analysis and Reporting Technology, is a special function that allows a memory device to automatically monitor its health. Apacer provides a program named SmartInfo Tool to observe Apacer’s SD and MicroSD cards. Note that this tool can only support Apacer’s industrial SD and MicroSD cards. This tool will display firmware version, endurance life ratio, good block ratio, and so forth.

### 1.2.5 Power Failure Management

Apacer industrial SD and MicroSD cards provide complete data protection mechanism during every abnormal power shutdown situation, such as power failure at programming data, updating system tables, erasing blocks, etc. Apacer Power-Loss Protection mechanism includes:

- Maintaining data correctness and increasing the reliability of the data stored in the NAND Flash memory.
- Protecting F/W table and the data written to flash from data loss in the event of power off.

### 1.2.6 SMART Read Refresh™

Apacer’s SMART Read Refresh plays a proactive role in avoiding read disturb errors from occurring to ensure health status of all blocks of NAND flash. Developed for read-intensive applications in particular, SMART Read Refresh is employed to make sure that during read operations, when the read operation threshold is reached, the data is refreshed by re-writing it to a different block for subsequent use.

## 2. Product Specifications

### 2.1 Card Architecture

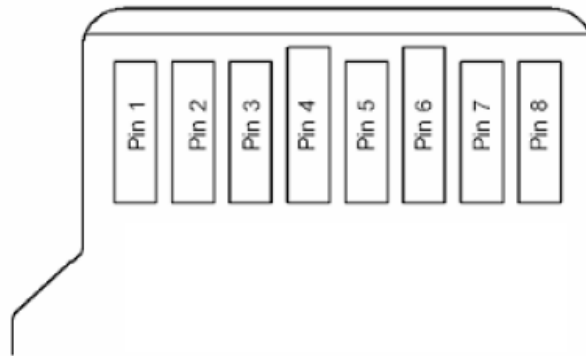

Figure 2-1 Card Architecture

### 2.2 Pin Assignment

Table 2-1 Pin Descriptions

Pin	SD Mode		SPI Mode	
	Name	Description	Name	Description
1	DAT2	Data line[bit 2]	Reserved	
2	CD/DAT3	Card Detect/Data line [bit 3]	CS	Chip select
3	CMD	Command/Response	DI	Data in
4	VDD	Supply voltage	VDD	Supply voltage
5	CLK	Clock	SCLK	Clock
6	VSS	Supply voltage ground	VSS	Supply voltage ground
7	DAT0	Data line[bit 0]	DO	Data out
8	DAT1	Data line[bit 1]	Reserved	

## 2.3 Capacity

The following table shows the specific capacity for the SD 3.0 card.

**Table 2-2** Capacity Specifications

Capacity	Total bytes*
4 GB	3,967,811,584
8 GB	7,944,011,776
16 GB	15,896,412,160
32 GB	31,797,018,624
64 GB	64,189,628,416
128 GB	128,261,816,320

Note: Total bytes are viewed under Windows operating system and were measured by SD format too.

## 2.4 Performance

Performances of the SD 3.0 card are shown in the table below.

**Table 2-3** Performance Specifications

Capacity	4 GB	8 GB	16 GB	32 GB	64 GB	128 GB
<b>Performance</b>						
<b>Sequential Read* (MB/s)</b>	85	90	90	90	90	90
<b>Sequential Write* (MB/s)</b>	14	25	49	75	75	75

Note:

Results may differ from various flash configurations or host system setting.

\*Sequential performance is based on CrystalDiskMark 5.2.1 with file size 1,000MB.

## 2.5 Electrical

**Table 2-4** Operating Voltages

Symbol	Parameter	Min.	Max.	Unit
V <sub>DD</sub>	Power Supply Voltage	2.7	3.6	V

**Table 2-5** Power Consumption

Capacity	4 GB	8 GB	16 GB	32 GB	64 GB	128 GB
<b>Mode</b>						
<b>Operating (mA)</b>	60	70	105	170	180	180
<b>Standby (µA)</b>	190	200	230	240	330	475

Note:

\*All values are typical and may vary depending on flash configurations or host system settings.

\*\*Active power is an average power measurement performed using CrystalDiskMark with 128KB sequential read/write transfers.

\*\*\*Power is measured based on USB 3.0 card reader.

### 3. Physical Characteristics

#### 3.1 Physical Dimensions

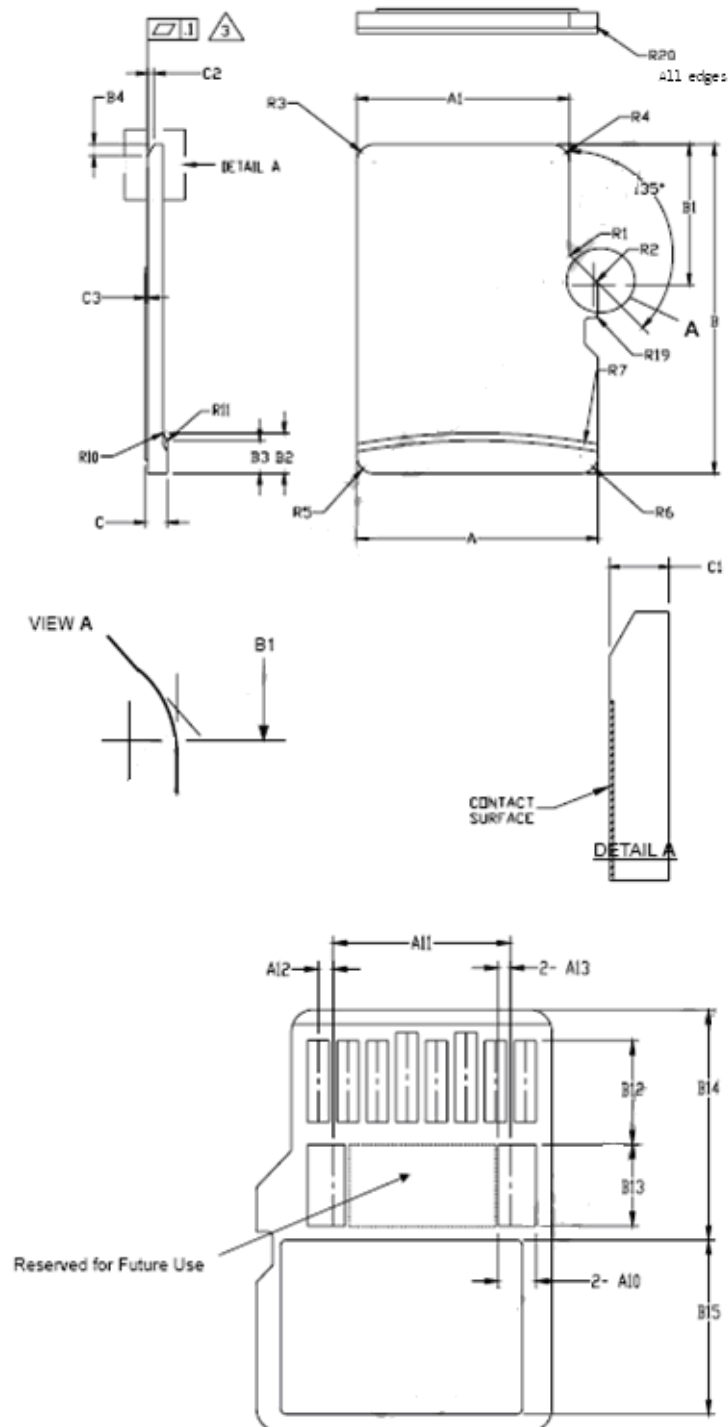

SYMBOL	COMMON DIMENSIONS			NOTE
	MIN	NOM	MAX	
A	10.90	11.00	11.10	
A1	9.60	9.70	9.80	
A2	-	3.85	-	BASIC
A3	7.60	7.70	7.80	
A4	-	1.10	-	BASIC
A5	0.75	0.80	0.85	
A6	-	-	8.50	
A7	0.90	-	-	
A8	0.60	0.70	0.80	
A9	0.80	-	-	
A10	1.35	1.40	1.45	
A11	6.50	6.60	6.70	
A12	0.50	0.55	0.60	
A13	0.40	0.45	0.50	
B	14.90	15.00	15.10	
B1	6.30	6.40	6.50	
B2	1.64	1.84	2.04	
B3	1.30	1.50	1.70	
B4	0.42	0.52	0.62	
B5	2.80	2.90	3.00	
B6	5.50	-	-	
B7	0.20	0.30	0.40	
B8	1.00	1.10	1.20	
B9	-	-	9.00	
B10	7.80	7.90	8.00	
B11	1.10	1.20	1.30	
B12	3.60	3.70	3.80	
B13	2.80	2.90	3.00	
B14	8.20	-	-	
B15	-	-	6.20	
C	0.90	1.00	1.10	
C1	0.60	0.70	0.80	
C2	0.20	0.30	0.40	
C3	0.00	-	0.15	
D1	1.00	-	-	
D2	1.00	-	-	
D3	1.00	-	-	
R1	0.20	0.40	0.60	
R2	0.20	0.40	0.60	
R3	0.70	0.80	0.90	
R4	0.70	0.80	0.90	
R5	0.70	0.80	0.90	
R6	0.70	0.80	0.90	
R7	29.50	30.00	30.50	
R10	-	0.20	-	
R11	-	0.20	-	
R17	0.10	0.20	0.30	
R18	0.20	0.40	0.60	
R19	0.05	-	0.20	
R20	0.02	-	0.15	

Notes:

1. DIMENSIONING AND TOLERANCING PER ASME Y14.5M-1994.
2. DIMENSIONS ARE IN MILLIMETERS.
3.  COPLANARITY IS ADDITIVE TO C1 MAX THICKNESS.

### 3.2 Durability Specifications

**Table 3-1** Durability Specifications

Item	Specifications
Temperature	-25°C to 85°C (Operating) -40°C to 85°C (Wide)
	-40°C to 85°C (Storage)
Shock	1,500G, 0.5ms
Vibration	20Hz~80Hz/1.52mm (frequency/displacement) 80Hz~2000Hz/20G (frequency/displacement) X, Y, Z axis/60mins each
Drop	150cm free fall, 6 face of each
Bending	≥ 10N, hold 1min/5times
Torque	0.1N-m or 2.5deg, hold 5min/5times
Salt Spray	Concentration: 3% NaCl at 35°C (storage for 24 hours)
Waterproof	JIS IPX7 compliance Water temperature 25°C Water depth: the lowest point of unit is locating 1000mm below surface (storage for 30 mins)
X-Ray Exposure	0.1 Gy of medium-energy radiation (70 KeV to 140 KeV, cumulative dose per year) to both sides of the card (storage for 30 mins)
Durability	10,000 times mating cycle
ESD	Pass

## 4. AC Characteristics

### 4.1 MicroSD Interface Timing (Default)

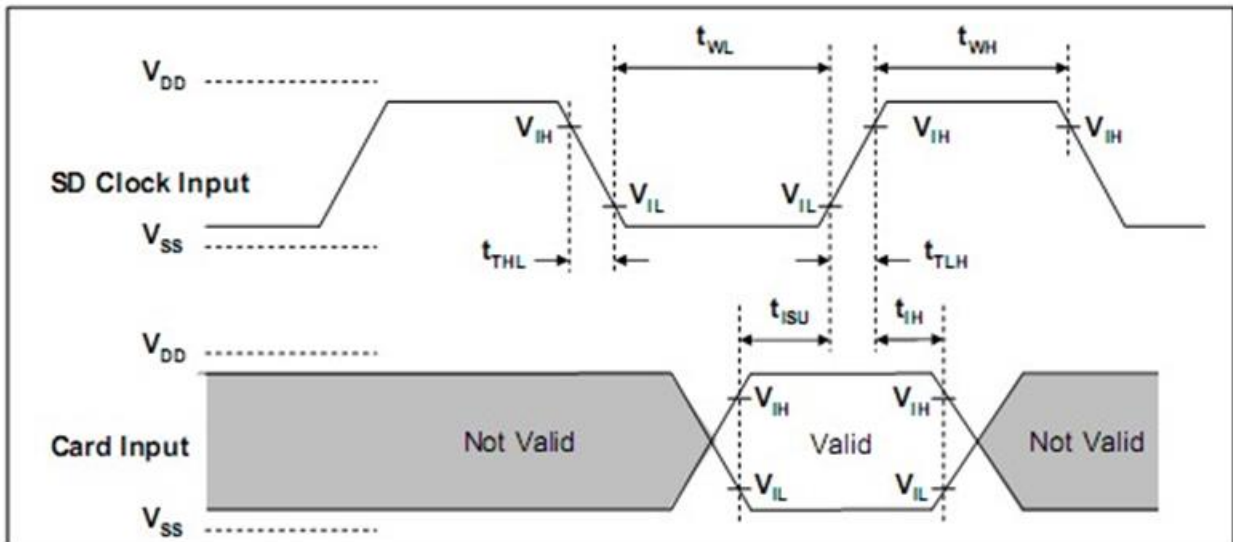

Card input Timing (Default Speed Card)

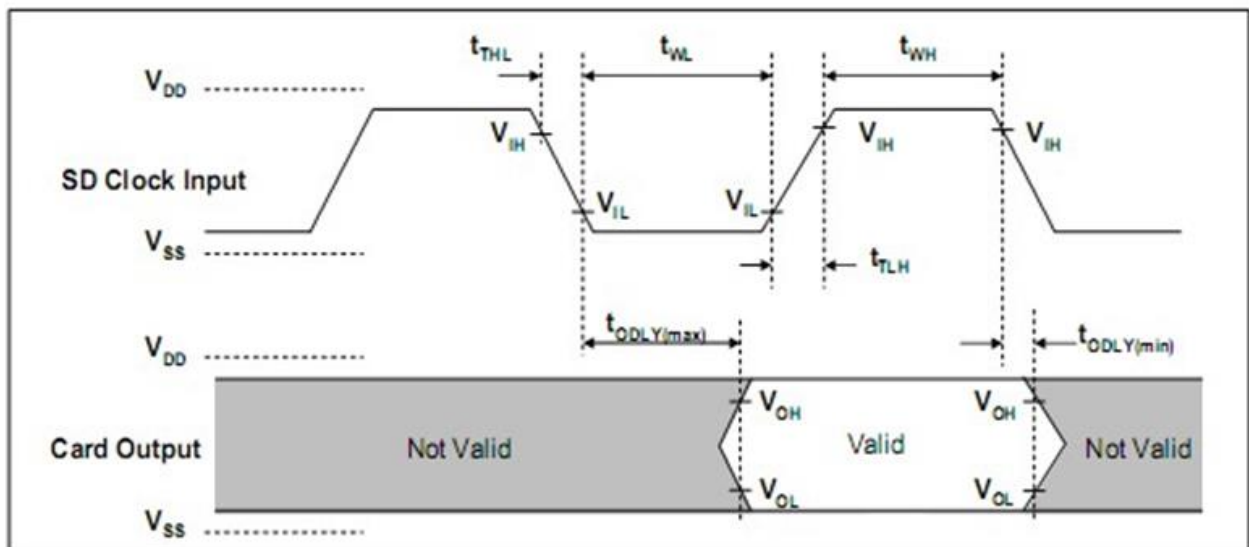

Card Output Timing (Default Speed Mode)

SYMBOL	PARAMETER	MIN	MAX	UNIT	REMARK
<b>Clock CLK (All values are referred to min(V<sub>IH</sub>) and max(V<sub>IL</sub>))</b>					
f <sub>PP</sub>	Clock frequency data transfer	0	25	MHz	C <sub>card</sub> ≤ 10 pF (1 card)
f <sub>OD</sub>	Clock frequency identification	0 <sup>(1)</sup> /100	400	KHz	C <sub>card</sub> ≤ 10 pF (1 card)
t <sub>WL</sub>	Clock low time	10	-	ns	C <sub>card</sub> ≤ 10 pF (1 card)
t <sub>WH</sub>	Clock high time	10	-	ns	C <sub>card</sub> ≤ 10 pF (1 card)
t <sub>TLH</sub>	Clock rise time	-	10	ns	C <sub>card</sub> ≤ 10 pF (1 card)
t <sub>THL</sub>	Clock fall time	-	10	ns	C <sub>card</sub> ≤ 10 pF (1 card)
<b>Inputs CMD, DAT (Referenced to CLK)</b>					
t <sub>ISU</sub>	Input setup time	5	-	ns	C <sub>card</sub> ≤ 10 pF (1 card)
t <sub>IH</sub>	Input hold time	5	-	ns	C <sub>card</sub> ≤ 10 pF (1 card)
<b>Outputs CMD, DAT (Referenced to CLK)</b>					
t <sub>ODLY</sub>	Output delay time during data transfer mode	0	14	ns	C <sub>L</sub> ≤ 40 pF (1 card)
t <sub>OH</sub>	Output hold time	0	50	ns	C <sub>L</sub> ≤ 40 pF (1 card)

(1)0Hz means to stop the clock. The given minimum frequency range is for cases that require the clock to be continued.

## 4.2 MicroSD Interface Timing (High Speed Mode)

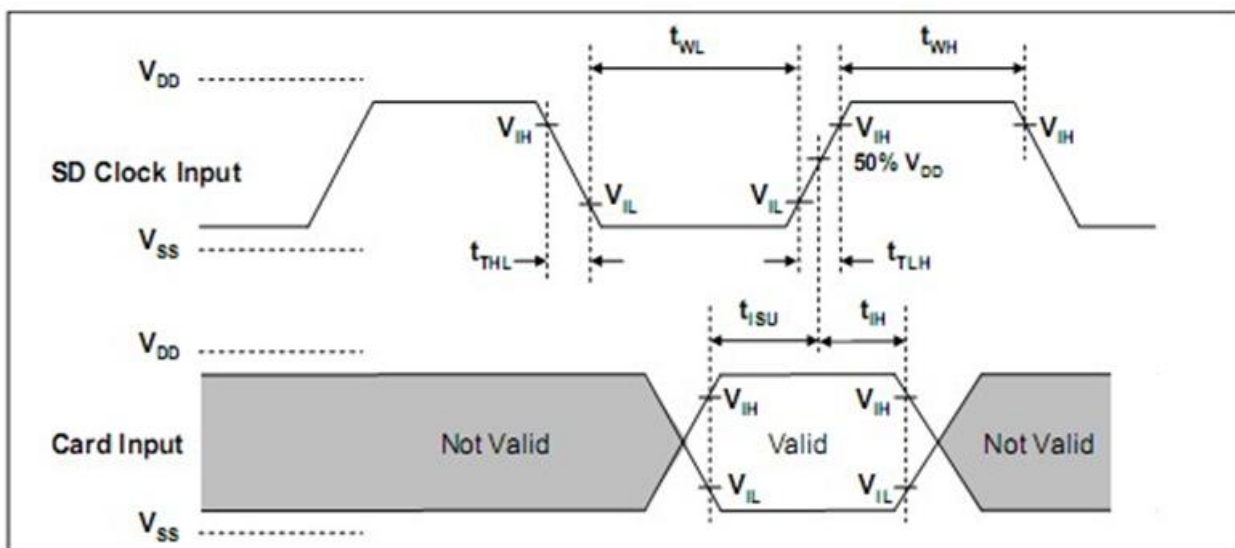

**Card Input Timing (High Speed Card)**

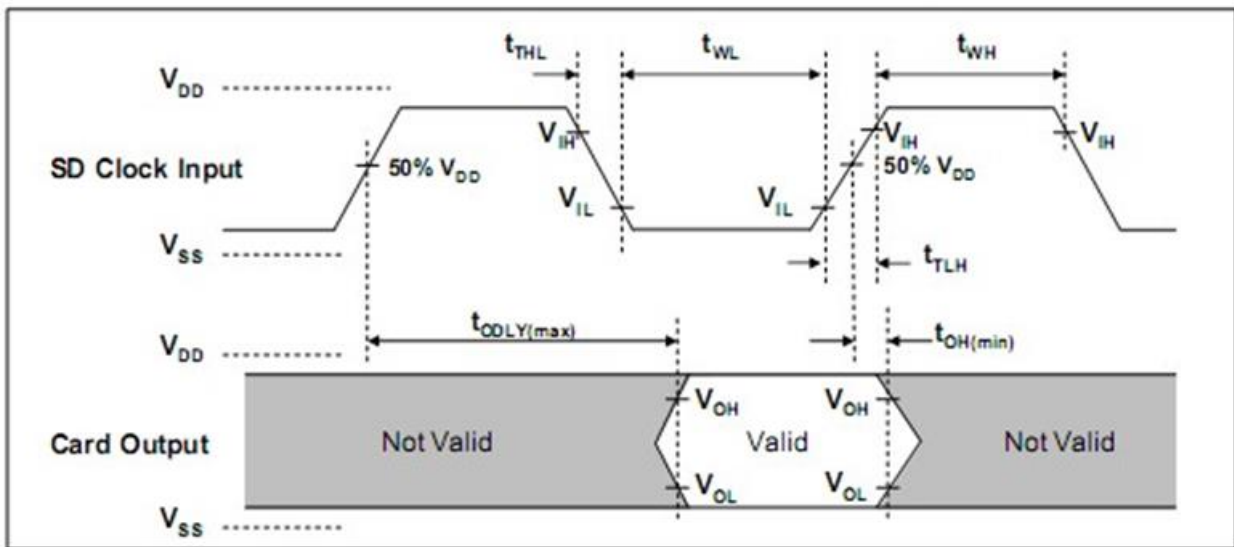

**Card Output Timing (High Speed Mode)**

SYMBOL	PARAMETER	MIN	MAX	UNIT	REMARK
<b>Clock CLK (All values are referred to min(<math>V_{IH}</math>) and max(<math>V_{IL}</math>))</b>					
$f_{PP}$	Clock frequency data transfer	0	50	MHz	$C_{card} \leq 10 \text{ pF}$ (1 card)
$t_{WL}$	Clock low time	7	-	ns	$C_{card} \leq 10 \text{ pF}$ (1 card)
$t_{WH}$	Clock high time	7	-	ns	$C_{card} \leq 10 \text{ pF}$ (1 card)
$t_{TLH}$	Clock rise time	-	3	ns	$C_{card} \leq 10 \text{ pF}$ (1 card)
$t_{THL}$	Clock fall time	-	3	ns	$C_{card} \leq 10 \text{ pF}$ (1 card)
<b>Inputs CMD, DAT (Referenced to CLK)</b>					
$t_{ISU}$	Input setup time	6	-	ns	$C_{card} \leq 10 \text{ pF}$ (1 card)
$t_{IH}$	Input hold time	2	-	ns	$C_{card} \leq 10 \text{ pF}$ (1 card)
<b>Outputs CMD, DAT (Referenced to CLK)</b>					
$t_{ODLY}$	Output delay time during data transfer made	-	14	ns	$CL \leq 40 \text{ pF}$ (1 card)
$t_{OH}$	Output hold time	2.5	-	ns	$CL \geq 15 \text{ pF}$ (1 card)
CL	Total system capacitance for each line*	-	40	pF	1 card

\*In order to satisfy severe timing, host shall run on only one card

### 4.3 MicroSD Interface Timing (SDR12, SDR25, SDR50 and SDR104 Modes)

#### 4.3.1 Clock Timing

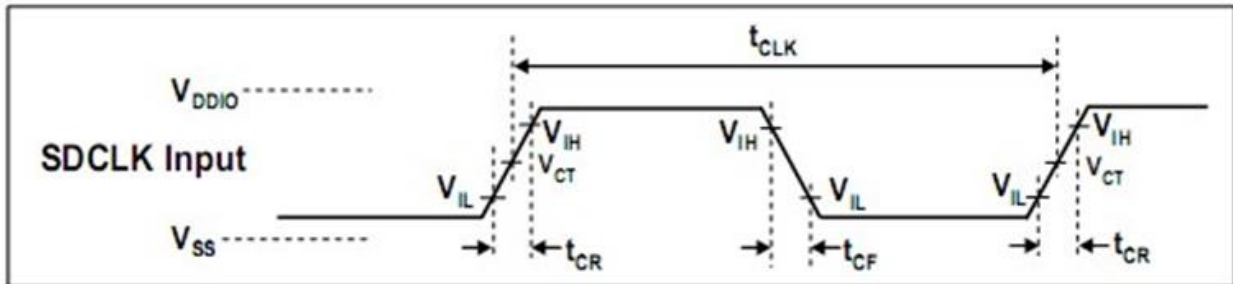

**Clock Signal Timing**

SYMBOL	MIN	MAX	UNIT	REMARK
$t_{CLK}$	4.8	-	ns	208MHz (Max.), Between rising edge, $V_{CT} = 0.975V$
$t_{CR}, t_{CF}$	-	$0.2 * t_{CLK}$	ns	$t_{CR}, t_{CF} < 2.00ns$ (max.) at 208MHz, $C_{CARD}=10pF$ $t_{CR}, t_{CF} < 2.00ns$ (max.) at 100MHz, $C_{CARD}=10pF$ The absolute maximum value of $t_{CR}, t_{CF}$ is 10ns regardless of clock frequency.
Clock Duty	30	70	%	

#### 4.3.2 Card Input Timing

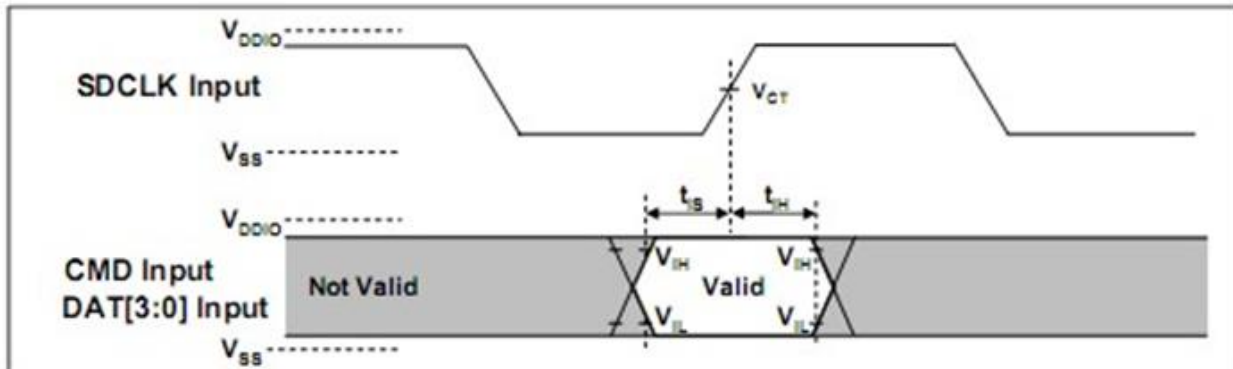

**Card Input Timing**

SYMBOL	MIN	MAX	UNIT	SDR104 MODE
$t_{IS}$	1.40	-	ns	$C_{CARD} = 10pF, V_{CT} = 0.975V$
$t_{IH}$	0.80	-	ns	$C_{CARD} = 5pF, V_{CT} = 0.975V$
SYMBOL	MIN	MAX	UNIT	SDR12, SDR25 and SDR50 MODES
$t_{IS}$	3.00	-	ns	$C_{CARD} = 10pF, V_{CT} = 0.975V$
$t_{IH}$	0.80	-	ns	$C_{CARD} = 5pF, V_{CT} = 0.975V$

### 4.3.3 Card Output Timing of Fixed Data Window (SDR12, SDR25 and SDR50)

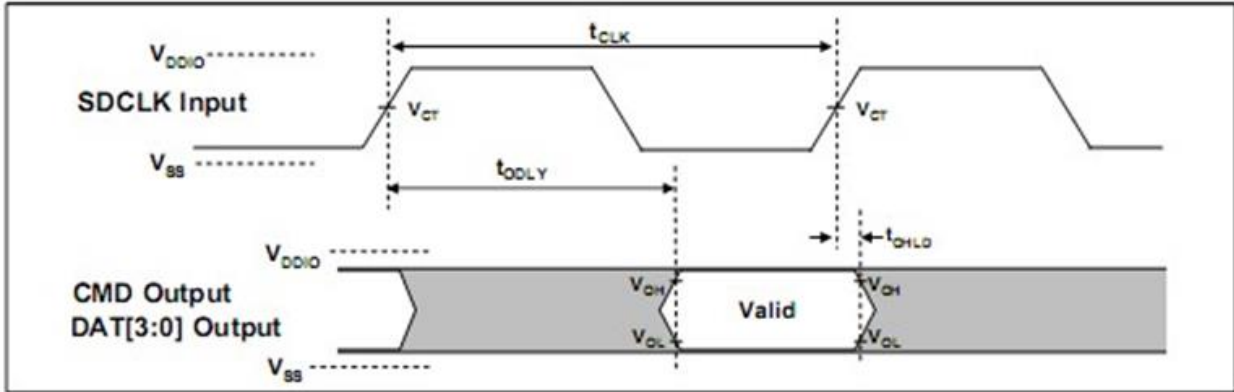

Output Timing of Fixed Date Window<sup>+</sup>

SYMBOL	MIN	MAX	UNIT	REMARK
$t_{ODLY}$	-	7.5	ns	$t_{CLK} \geq 10.0ns$ , $CL=30pF$ , using driver Type B, for SDR50.
$t_{ODLY}$		14	ns	$t_{CLK} \geq 20.0ns$ , $CL=40pF$ , using driver Type B, for SDR25 and SDR12.
$t_{OH}$	1.5	-	ns	Hold time at the $t_{ODLY}$ (min.). $CL=15pF$

### 4.3.4 Output Timing of Variable Window (SDR104)

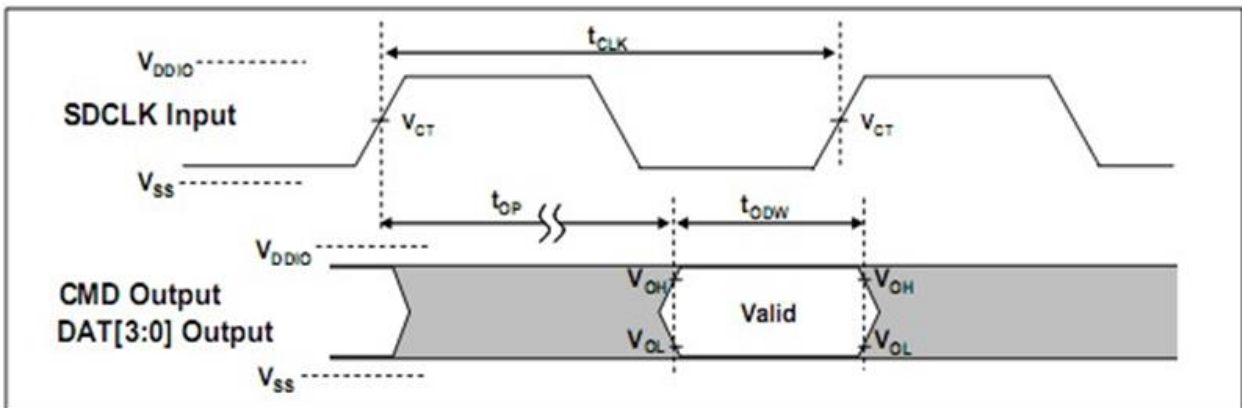

Output Timing of Variable Data Window<sup>+</sup>

SYMBOL	MIN	MAX	UNIT	REMARK
$t_{OP}$	-	2	UI	Card Output Phase
$\Delta t_{OP}$	-350	+1550	ps	Delay variation due to temperature change after tuning
$t_{ODW}$	0.60	-	UI	$t_{ODW} = 2.88ns$ at 208MHz

### 4.3.5 SD Interface Timing (DDR50 Mode)

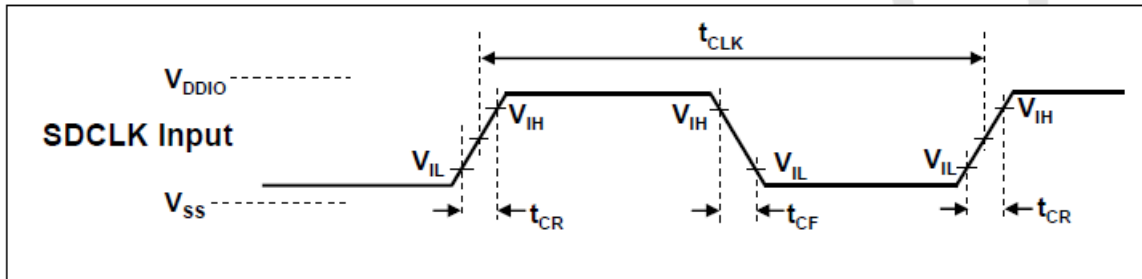

#### Clock Signal Timing

SYMBOL	MIN	MAX	UNIT	REMARK
$t_{CLK}$	20	-	ns	50MHz (Max.), Between rising edge
$t_{CR}, t_{CF}$	-	$0.2 \cdot t_{CLK}$	ns	$t_{CR}, t_{CF} < 4.00\text{ns (max.)}$ at 50MHz, CCARD=10pF
Clock Duty	45	55	%	

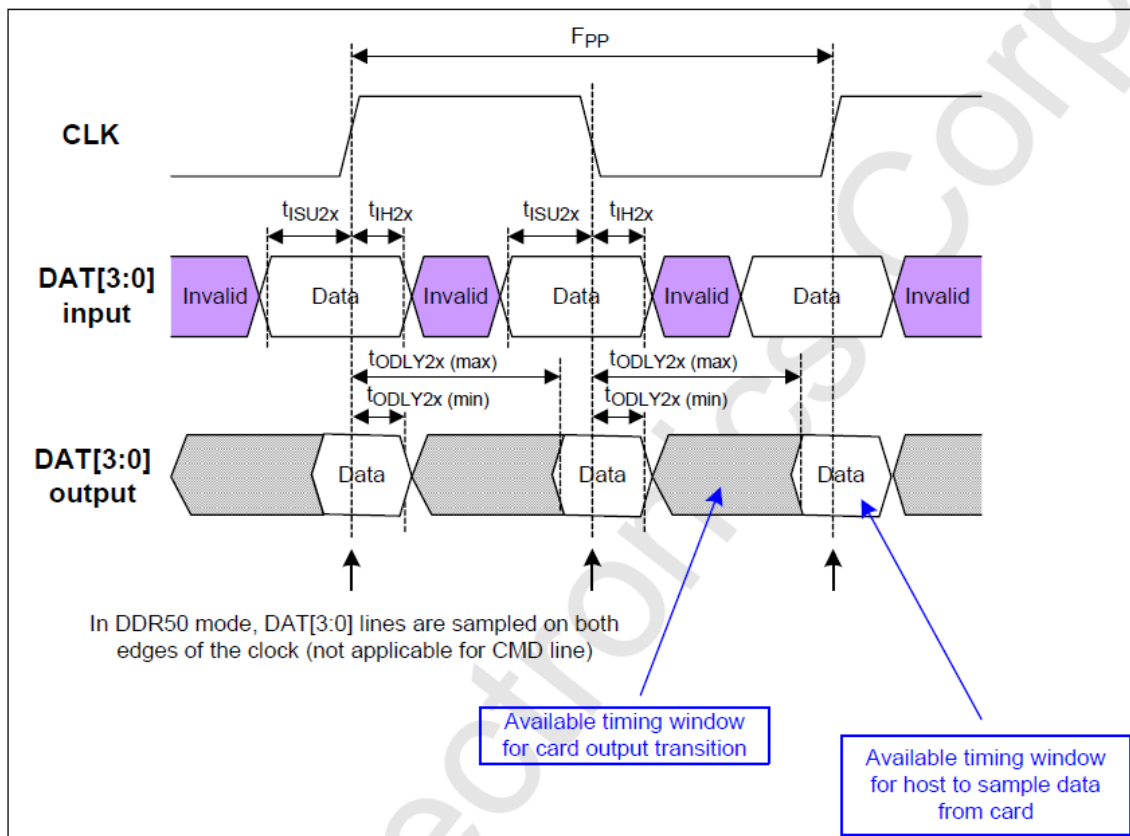

Timing Diagram DAT Inputs/Outputs Referenced to CLK in DDR50 Mode

### 4.3.6 Bus Timings – Parameters Values (DDR50 Mode)

Symbol	Parameters	Min	Max	Unit	Remark
<b>Input CMD</b> (referenced to CLK rising edge)					
t <sub>ISU</sub>	Input set-up time	6	-	ns	C <sub>card</sub> ≤ 10 pF (1 card)
t <sub>IH</sub>	Input hold time	0.8	-	ns	C <sub>card</sub> ≤ 10 pF (1 card)
<b>Output CMD</b> (referenced to CLK rising edge)					
t <sub>ODLY</sub>	Output Delay time during Data Transfer Mode	-	13.7	ns	C <sub>L</sub> ≤ 30 pF (1 card)
T <sub>OH</sub>	Output Hold time	1.5	-	ns	C <sub>L</sub> ≥ 15 pF (1 card)
<b>Inputs DAT</b> (referenced to CLK rising and falling edges)					
t <sub>ISU2x</sub>	Input set-up time	3	-	ns	C <sub>card</sub> ≤ 10 pF (1 card)
t <sub>IH2x</sub>	Input hold time	0.8	-	ns	C <sub>card</sub> ≤ 10 pF (1 card)
<b>Outputs DAT</b> (referenced to CLK rising and falling edges)					
t <sub>ODLY2x</sub>	Output Delay time during Data Transfer Mode	-	7.0	ns	C <sub>L</sub> ≤ 25 pF (1 card)
T <sub>OH2x</sub>	Output Hold time	1.5	-	ns	C <sub>L</sub> ≥ 15 pF (1 card)

## 5. S.M.A.R.T.

### 5.1 Direct Host Access to SMART Data via SD General Command (CMD56)

CMD 56 is structured as a 32-bit argument. The implementation of the general purpose functions will arrange the CMD56 argument into the following format:

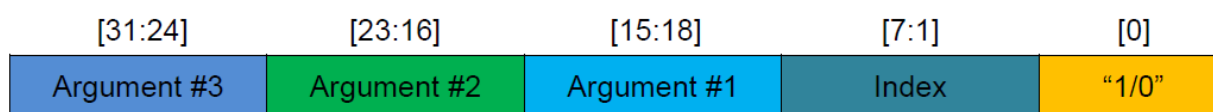

- Bit [0]: Indicates Read Mode when bit is set to [1] or Write Mode when bit is cleared [0]. Depending on the function, either Read Mode or Write Mode can be used.
- Bit [7:1]: Indicates the index of the function to be executed:
  - Read Mode: Index = 0x10 Get SMART Command Information
  - Write Mode: Index = 0x08 Pre-Load SMART Command Information
- Bit [15:8]: Function argument #1 (1-byte)
- Bit [23:16]: Function argument #2 (1-byte)
- Bit [31:24]: Function argument #3 (1-byte)

### 5.2 Process for Retrieving SMART Data

Retrieving SMART data requires the following two commands executed in sequence and in accordance with the SD Association standard flowchart for CMD56 (see below).

#### Step 1: Write Mode – [0x08] Pre-Load SMART Command Information

Sequence	Command	Argument	Expected Data
Pre-Load SMART Command Information	CMD56	[0] "0" (Write Mode) [1:7] "0001 000" (Index = 0x08) [8:511] All '0' (Reserved)	No expected data

**Step 2: Read Mode – [0x10] Get SMART Command Information**

Sequence	Command	Argument	Expected Data
Get SMART Command Information	CMD56		1 sector (512 bytes) of response data
		[0] "1" (Read Mode) [1:7] "0010 000" (Index = 0x10) [8:31] All '0' (Reserved)	byte[0-8] Flash ID byte[9-10] IC Version byte[11-12] FW Version byte[13] Reserved byte[14] CE Number byte[15] Reserved byte[16-17] Bad Block Replace Maximum byte[18] Reserved byte[32-63] Bad Block count per Die byte[64-65] Good Block Rate(%) byte[66-79] Reserved byte[80-83] Total Erase Count byte[84-95] Reserved byte[96-97] Endurance (Remain Life) (%) byte[98-99] Average Erase Count – L* byte[100-101] Minimum Erase Count – L* byte[102-103] Maximum Erase Count – L* byte[104-105] Average Erase Count – H* byte[106-107] Minimum Erase Count – H* byte[108-109] Maximum Erase Count – H* byte[110-111] Reserved byte[112-115] Power Up Count byte[116-127] Reserved byte[128-129] Abnormal Power Off Count byte[130-159] Reserved byte[160-161] Total Refresh Count byte[176-183] Product "Marker" byte[184-215] Bad Block count per Die byte[216-511] Reserved

\*Please refer to technical note for High/Low byte definition.

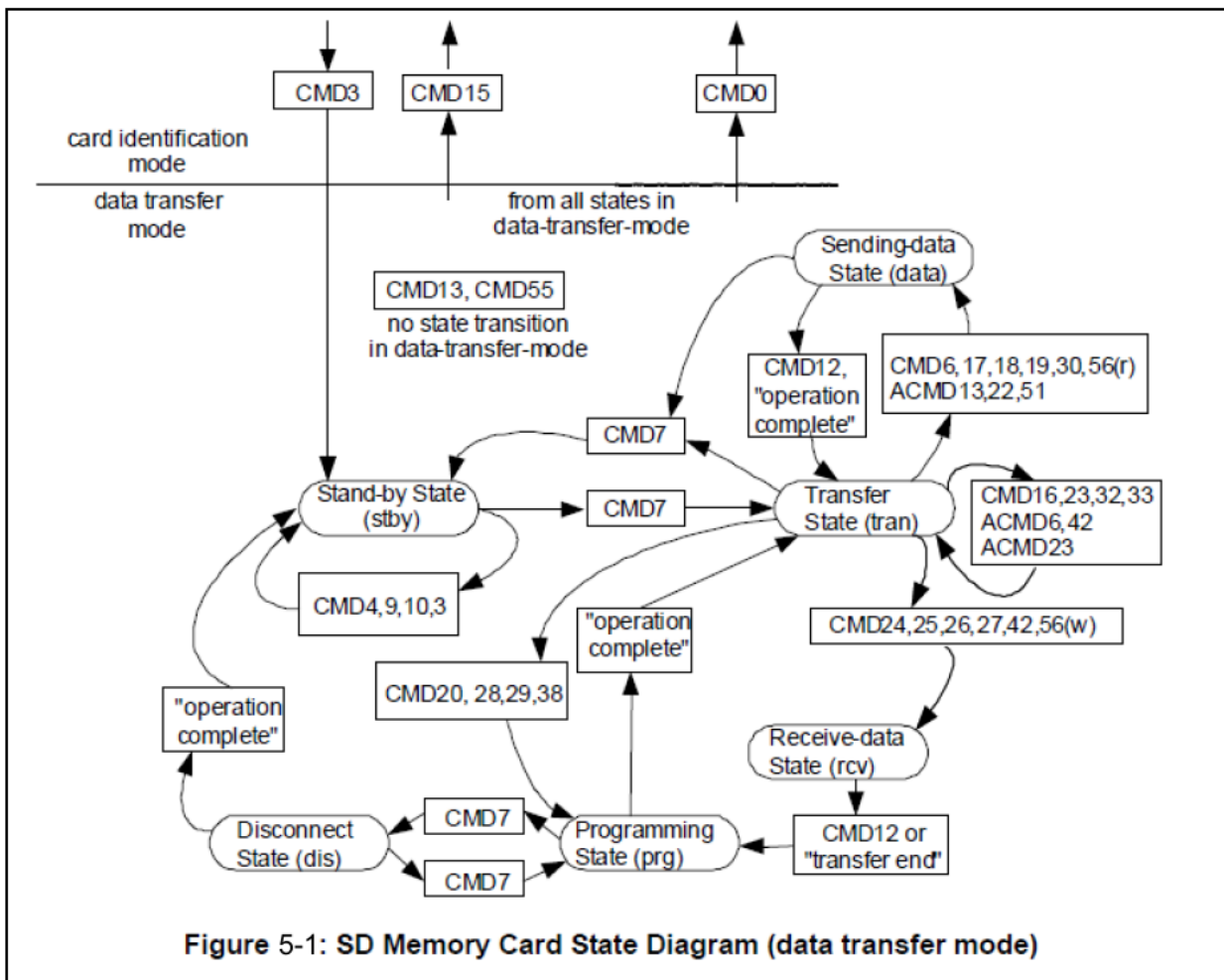
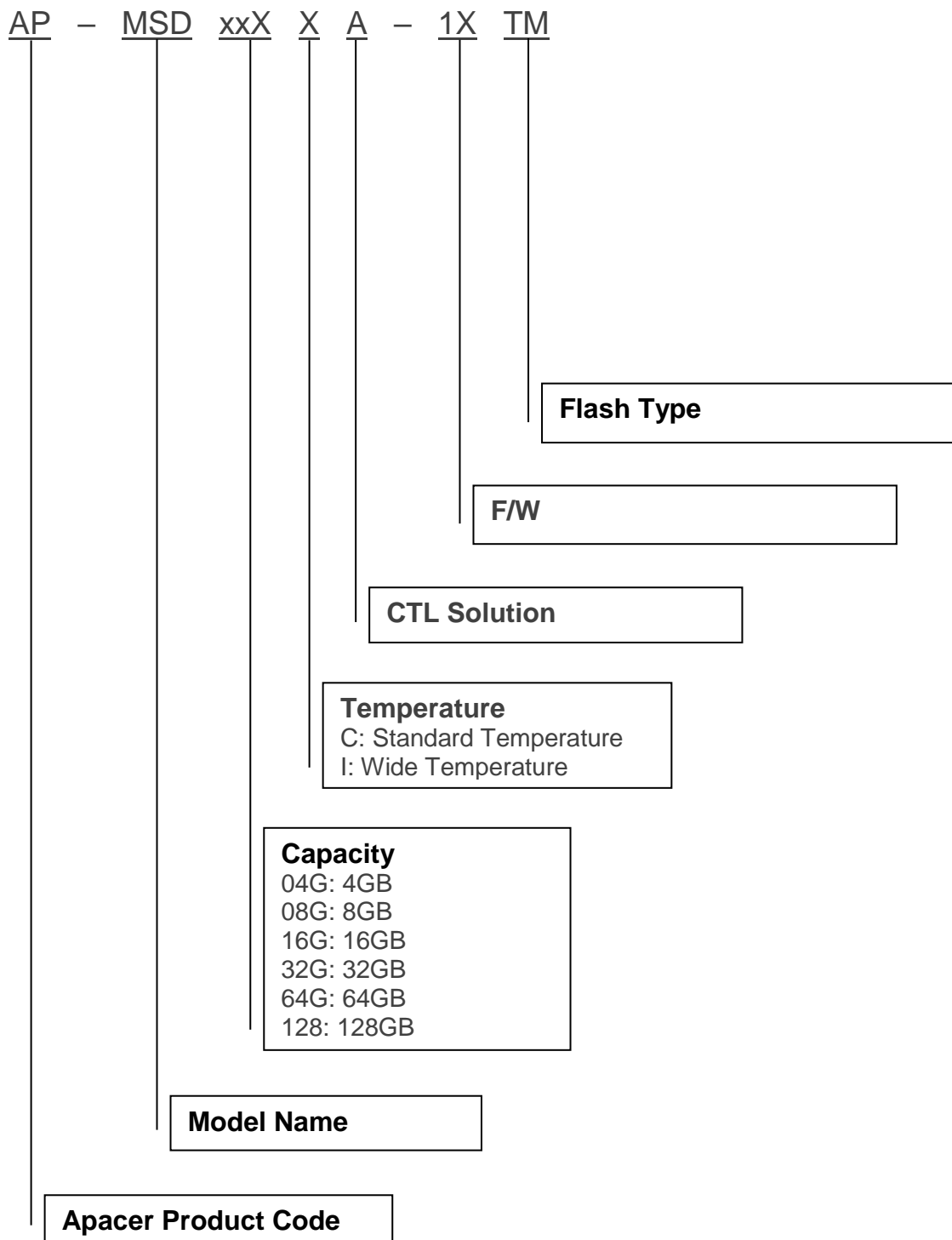

Figure 5-1: SD Memory Card State Diagram (data transfer mode)

Extracted from the SD Specifications Part 1 Physical Layer Simplified Specification Version 3.01.

## 6. Product Ordering Information

### 6.1 Product Code Designations



## 6.2 Valid Combinations

Capacity	Standard Temperature	Wide Temperature
4GB	AP-MSD04GCA-1HTM	AP-MSD04GIA-1HTM
8GB	AP-MSD08GCA-1HTM	AP-MSD08GIA-1HTM
16GB	AP-MSD16GCA-1HTM	AP-MSD16GIA-1HTM
32GB	AP-MSD32GCA-1HTM	AP-MSD32GIA-1HTM
64GB	AP-MSD64GCA-1FTM	AP-MSD64GIA-1FTM
128GB	AP-MSD128GCA-1JTM	AP-MSD128GIA-1JTM

**Note:** Valid combinations are those products in mass production or will be in mass production. Consult your Apacer sales representative to confirm availability of valid combinations and to determine availability of new combinations.

## Revision History

Revision	Description	Date
1.0	Official release	11/16/2015
1.1	Removed switch cycle from Durability Specifications	12/7/2015
1.2	Added CMD56 argument for SMART	12/16/2015
1.3	Added SMART section	12/23/2015
1.4	Added 4GB support	2/2/2016
1.5	Revised product ordering information for 4GB, 8GB, 16GB and 32GB due to FW update	3/15/2016
1.6	Revised product ordering information for 4GB-32GB due to FW change (82.105)	7/29/2016
1.7	Added Power Failure Management to Features and General Description	10/3/2016
1.8	Removed “The data written at the exact moment power off will be lost, and the max data loss is 16 sectors.” from 1.2.5 Power Failure Management	10/7/2016
1.9	Modified the argument of Step 2: Read Mode – [0x10] Get SMART Command Information for S.M.A.R.T.	10/27/2016
2.0	- Added 128GB support - Updated product ordering information	2/7/2017
2.1	Added a product photo to cover page	2/16/2017
2.2	Removed write protect support	7/31/2017
2.3	- Updated UHS-1 Bus speed mode on Features page - Added Read Disturb Management to Flash Management on Features page - Added 1.2.6 Read Disturb Management - Modified Wear Leveling to Global Wear Leveling	8/17/2017
2.4	Updated performance and power consumption	8/18/2017
2.5	Renamed extended temperature and Read Disturb Management to wide temperature and SMART Read Refresh respectively	10/16/2020

## Global Presence

### Taiwan (Headquarters)

#### Apacer Technology Inc.

1F., No.32, Zhongcheng Rd., Tucheng Dist.,  
New Taipei City 236, Taiwan R.O.C.  
Tel: 886-2-2267-8000  
Fax: 886-2-2267-2261  
[amtsales@apacer.com](mailto:amtsales@apacer.com)

### U.S.A.

#### Apacer Memory America, Inc.

46732 Lakeview Blvd., Fremont, CA 94538  
Tel: 1-408-518-8699  
Fax: 1-510-249-9551  
[sa@apacerus.com](mailto:sa@apacerus.com)

### Japan

#### Apacer Technology Corp.

6F, Daiyontamachi Bldg., 2-17-12, Shibaura, Minato-Ku,  
Tokyo, 108-0023, Japan  
Tel: 81-3-5419-2668  
Fax: 81-3-5419-0018  
[jpservices@apacer.com](mailto:jpservices@apacer.com)

### Europe

#### Apacer Technology B.V.

Science Park Eindhoven 5051 5692 EB Son,  
The Netherlands  
Tel: 31-40-267-0000  
Fax: 31-40-290-0686  
[sales@apacer.nl](mailto:sales@apacer.nl)

### China

#### Apacer Electronic (Shanghai) Co., Ltd

Room D, 22/FL, No.2, Lane 600, JieyunPlaza,  
Tianshan RD, Shanghai, 200051, China  
Tel: 86-21-6228-9939  
Fax: 86-21-6228-9936  
[sales@apacer.com.cn](mailto:sales@apacer.com.cn)

### India

#### Apacer Technologies Pvt Ltd,

1874, South End C Cross, 9<sup>th</sup> Block Jayanagar,  
Bangalore-560069, India  
Tel: 91-80-4152-9061/62  
Fax: 91-80-4170-0215  
[sales\\_india@apacer.com](mailto:sales_india@apacer.com)