

**RoHS Recast Compliant**

## **Industrial microSD 5.0**

**CH210-MSD Product Specifications**  
(WD TLC BiCS4 96 Layers)

**June 9, 2021**

**Version 1.0**



**Apacer Technology Inc.**

1F, No.32, Zhongcheng Rd., Tucheng Dist., New Taipei City, Taiwan, R.O.C

Tel: +886-2-2267-8000 Fax: +886-2-2267-2261

[www.apacer.com](http://www.apacer.com)

## Specifications Overview:

- **Fully Compatible with SD Card Association Specifications**
  - Physical Layer Specification Ver6.1
  - Security Specification Ver5.0
- **Capacity**
  - 16, 32, 64 GB
- **Performance\***
  - Sequential read: Up to 90 MB/sec
  - Sequential write: Up to 70 MB/sec
  - Random read (4K): Up to 1,300 IOPS
  - Random write (4K): Up to 300 IOPS
- **Flash Management**
  - Built-in advanced ECC algorithm
  - Global Wear Leveling
  - Flash bad-block management
  - Power Failure Management
  - Flash Translation Layer: Page Mapping
  - S.M.A.R.T.
  - SMART Read Refresh™
  - SLC-liteX
- **NAND Flash Type:** WD TLC BiCS4 96 Layers
- **SD-Protocol Compatible**
- **Supports SD SPI Mode**
- **Backward Compatible with 3.0 and 2.0**
- **Endurance (in Terabytes Written: TBW)**
  - 16 GB: 195 TBW
  - 32 GB: 382 TBW
  - 64 GB: 713 TBW
- **Temperature Range**
  - Operating: -25°C to 85°C
  - Storage: -40°C to 85°C
- **Operating Voltage: 2.7V ~ 3.6V**
- **Power Consumption\***
  - Operating: 70 mA
  - Standby: 260 µA
- **Bus Speed Mode:** Supports Class 10 with U3 and UHS-I\*\*
  - SDR12: SDR up to 25MHz 1.8V signaling
  - SDR25: SDR up to 50MHz 1.8V signaling
  - SDR50: 1.8V signaling, frequency up to 100MHz, up to 50 MB/sec
  - SDR104: 1.8V signaling, frequency up to 208MHz, up to 104MB/sec
  - DDR50: 1.8V signaling, frequency up to 50MHz, sampled on both clock edges, up to 50 MB/sec
- **Physical Dimensions**
  - 15mm (L) x 11mm (W) x 1mm (H)
- **Supports Video Speed Class: V30**
- **RoHS Recast Compliant**

\*Performance values presented here are typical and measured based on USB 3.0 card reader. The results may vary depending on settings and platforms.

\*\*Timing in 1.8V signaling is different from that of 3.3V signaling. Operation mode selection command is compliant with SD 3.0, referring to SDA's Part 1, Physical Layer Specification, Ver 3.01 (Section 3.9).

## Table of Contents

<b>1. General Descriptions .....</b>	<b>4</b>
1.1 Functional Block.....	4
1.2 Flash Management .....	5
1.2.1 Bad Block Management.....	5
1.2.2 Powerful ECC Algorithms .....	5
1.2.3 Global Wear Leveling .....	5
1.2.4. Power Failure Management.....	5
1.2.5 S.M.A.R.T. ....	5
1.2.6 SMART Read Refresh™.....	5
1.2.7 Flash Translation Layer – Page Mapping.....	6
1.2.8 SLC-liteX.....	6
<b>2. Product Specifications.....</b>	<b>7</b>
2.1 Card Architecture .....	7
2.2 Pin Assignment .....	7
2.3 Capacity.....	8
2.4 Performance.....	8
2.5 Electrical.....	8
2.6 Endurance .....	9
<b>3. Physical Characteristics.....</b>	<b>10</b>
3.1 Physical Dimensions.....	10
3.2 Durability Specifications.....	12
<b>4. AC Characteristics .....</b>	<b>13</b>
4.1 microSD Interface Timing (Default) .....	13
4.2 microSD Interface Timing (High Speed Mode) .....	14
4.3 microSD Interface Timing (SDR12, SDR25, SDR50 and SDR104 Modes).....	16
4.3.1 Clock Timing .....	16
4.3.2 Card Input Timing .....	16
4.3.3 Card Output Timing of Fixed Data Window (SDR12, SDR25 and SDR50) .....	17
4.3.4 Output Timing of Variable Window (SDR104) .....	17
4.3.5 SD Interface Timing (DDR50 Mode).....	18
4.3.6 Bus Timings – Parameters Values (DDR50 Mode).....	19
<b>5. Product Ordering Information.....</b>	<b>20</b>

5.1 Product Code Designations .....	20
5.2 Valid Combinations .....	21

# 1. General Descriptions

Apacer microSD CH210-MSD is compatible with the microSD card version 5.0. The command list supports [Physical Layer Specification Ver6.10 Final] definitions. Card Capacity of Non-secure Area, Secure Area Supports [Part 3 Security Specification Ver5.0 Final] Specifications.

The microSD 5.0 card comes with 8-pin interface. It can alternate communication protocols between the SD mode and SPI mode. It performs data error detection and correction with very low power consumption. It supports capacity up to 64GB with exFAT SDXC.

Apacer microSD CH210-MSD Secure Digital 5.0 with high performance, good reliability and wide compatibility is nowadays one of the most popular cards with customized firmware techniques in semi-industrial/medical markets already.

## 1.1 Functional Block

The microSD contains a card controller and a memory core for the SD standard interface.

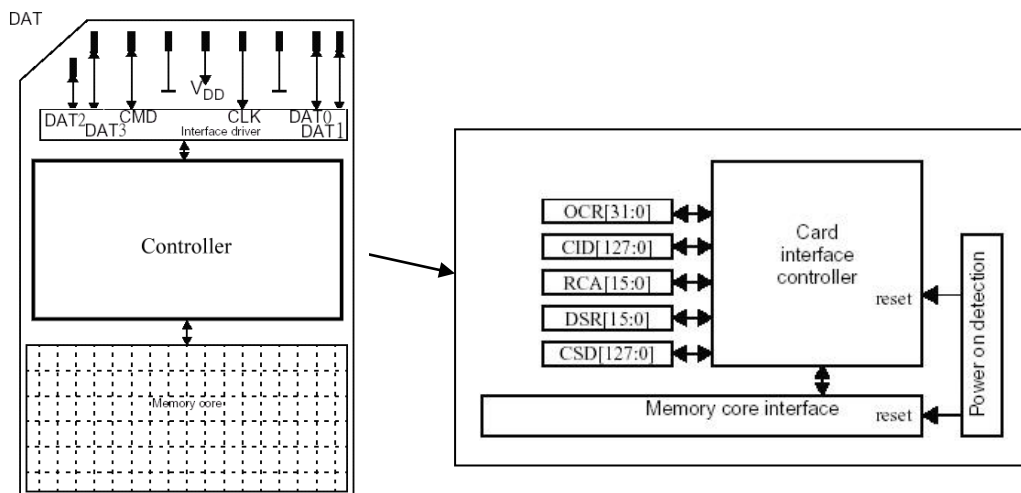

Figure 1-1 Functional Block Diagram

## 1.2 Flash Management

### 1.2.1 Bad Block Management

Bad blocks are blocks that include one or more invalid bits, and their reliability is not guaranteed. Blocks that are identified and marked as bad by the manufacturer are referred to as “Initial Bad Blocks”. Bad blocks that are developed during the lifespan of the flash are named “Later Bad Blocks”. Apacer implements an efficient bad block management algorithm to detect the factory-produced bad blocks and manages any bad blocks that appear with use. This practice further prevents data being stored into bad blocks and improves the data reliability.

### 1.2.2 Powerful ECC Algorithms

Flash memory cells will deteriorate with use, which might generate random bit errors in the stored data. To protect data from corruption, the microSD card whose controller supports up to 120bits ECC circuits applies the advanced ECC Algorithm that can detect and correct errors occur during read process.

### 1.2.3 Global Wear Leveling

NAND Flash devices can only undergo a limited number of program/erase cycles, and in most cases, the flash media are not used evenly. If some area get updated more frequently than others, the lifetime of the device would be reduced significantly. Thus, Global Wear Leveling technique is applied to extend the lifespan of NAND Flash by evenly distributing writes and erase cycles across the media.

Apacer provides Global Wear Leveling algorithm, which can efficiently spread out the flash usage through the whole flash media area. Moreover, by implementing Global Wear Leveling algorithm, the life expectancy of the NAND Flash is greatly improved.

### 1.2.4. Power Failure Management

Power Failure Management plays a crucial role when power supply becomes unstable. Power disruption may occur when users are storing data into the microSD card, leading to instability in the drive. However, with Power Failure Management, a firmware protection mechanism will be activated to scan pages and blocks once power is resumed. Valid data will be transferred to new blocks for merging and the mapping table will be rebuilt. Therefore, data reliability can be reinforced, preventing damage to data stored in the NAND Flash.

### 1.2.5 S.M.A.R.T.

SMART, an acronym for Self-Monitoring, Analysis and Reporting Technology, is a special function that allows a memory device to automatically monitor its health. Apacer provides a program named SmartInfo Tool to observe Apacer’s SD and microSD cards. Note that this tool can only support Apacer’s industrial SD and microSD cards. This tool will display firmware version, endurance life ratio, good block ratio, and so forth.

### 1.2.6 SMART Read Refresh™

Apacer’s SMART Read Refresh plays a proactive role in avoiding read disturb errors from occurring to ensure health status of all blocks of NAND flash. Developed for read-intensive applications in particular, SMART Read Refresh is employed to make sure that during read operations, when the read operation threshold is reached, the data is refreshed by re-writing it to a different block for subsequent use.

## 1.2.7 Flash Translation Layer – Page Mapping

Page mapping is an advanced flash management technology whose essence lies in the ability to gather data, distribute the data into flash pages automatically, and then schedule the data to be evenly written. Page-level mapping uses one page as the unit of mapping. The most important characteristic is that each logical page can be mapped to any physical page on the flash memory device. This mapping algorithm allows different sizes of data to be written to a block as if the data is written to a data pool and it does not need to take extra operations to process a write command. Thus, page mapping is adopted to increase random access speed and improve microSD lifespan, reduce block erase frequency, and achieve optimized performance and lifespan.

## 1.2.8 SLC-liteX

SLC-liteX is based on 3D NAND technology. The firmware is carefully tweaked by our engineering team so as to offer the greatest number of P/E cycles in this format – 30,000, which is 10 times more than MLC or industrial 3D TLC. The longest lifespans are therefore available at reasonable cost.

## 2. Product Specifications

### 2.1 Card Architecture

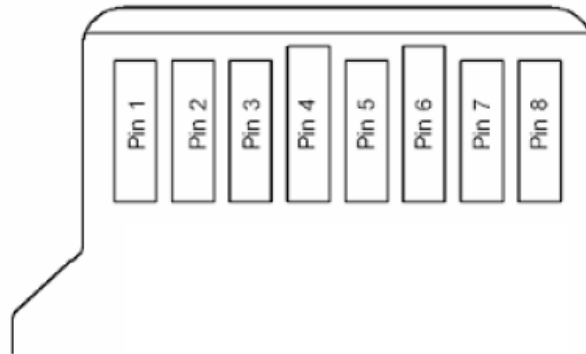

Figure 2-1 Card Architecture

### 2.2 Pin Assignment

Table 2-1 Pin Descriptions

Pin	SD Mode		SPI Mode	
	Name	Description	Name	Description
1	DAT2	Data line[bit 2]	Reserved	
2	CD/DAT3	Card Detect/Data line [bit 3]	CS	Chip select
3	CMD	Command/Response	DI	Data in
4	VDD	Supply voltage	VDD	Supply voltage
5	CLK	Clock	SCLK	Clock
6	VSS	Supply voltage ground	VSS	Supply voltage ground
7	DAT0	Data line[bit 0]	DO	Data out
8	DAT1	Data line[bit 1]	Reserved	

## 2.3 Capacity

The following table shows the specific capacity for the SD 6.1 card.

**Table 2-2** Capacity Specifications

Capacity	Total bytes*
16 GB	16,009,658,368
32 GB	32,099,975,744
64 GB	64,183,336,960

Note: Total bytes are viewed under Windows operating system and were measured by SD format too.

## 2.4 Performance

Performances of the SD 6.1 card are shown in the table below.

**Table 2-3** Performance Specifications

Capacity	16 GB	32 GB	64 GB
<b>Performance</b>			
<b>Sequential Read* (MB/s)</b>	85	90	90
<b>Sequential Write* (MB/s)</b>	48	70	70
<b>Random Read IOPS** (4K)</b>	1,300	1,300	1,200
<b>Random Write IOPS** (4K)</b>	200	300	200

Note:

Results may differ from various flash configurations or host system setting.

\*Sequential performance is based on CrystalDiskMark 5.2.1 with file size 1,000MB.

\*\*Random performance measured using IOMeter with Queue Depth 32.

\*\*\*Performance results are measured based on USB 3.0 card reader.

## 2.5 Electrical

**Table 2-4** Operating Voltages

Symbol	Parameter	Min.	Max.	Unit
V <sub>DD</sub>	Power Supply Voltage	2.7	3.6	V

**Table 2-5** Power Consumption

Capacity	16 GB	32 GB	64 GB
<b>Mode</b>			
<b>Operating (mA)</b>	70	70	70
<b>Standby (µA)</b>	245	230	260

Note:

\*All values are typical and may vary depending on flash configurations or host system settings.

\*\*Active power is an average power measurement performed using CrystalDiskMark with 128KB sequential read/write transfers.

\*\*\*Power is measured based on USB 3.0 card reader.

## 2.6 Endurance

The endurance of a storage device is predicted by TeraBytes Written based on several factors related to usage, such as the amount of data written into the drive, block management conditions, and daily workload for the drive. Thus, key factors, such as Write Amplifications and the number of P/E cycles, can influence the lifespan of the drive.

**Table 2-6** Endurance Specifications

Capacity	TeraBytes Written
16 GB	195
32 GB	382
64 GB	713

Note:

- This estimation complies with Apacer internal workload.
- Flash vendor guaranteed SLC-liteX P/E cycle: 30K
- WAF may vary from capacity, flash configurations and writing behavior on each platform.
- 1 Terabyte = 1,024GB

### 3. Physical Characteristics

#### 3.1 Physical Dimensions

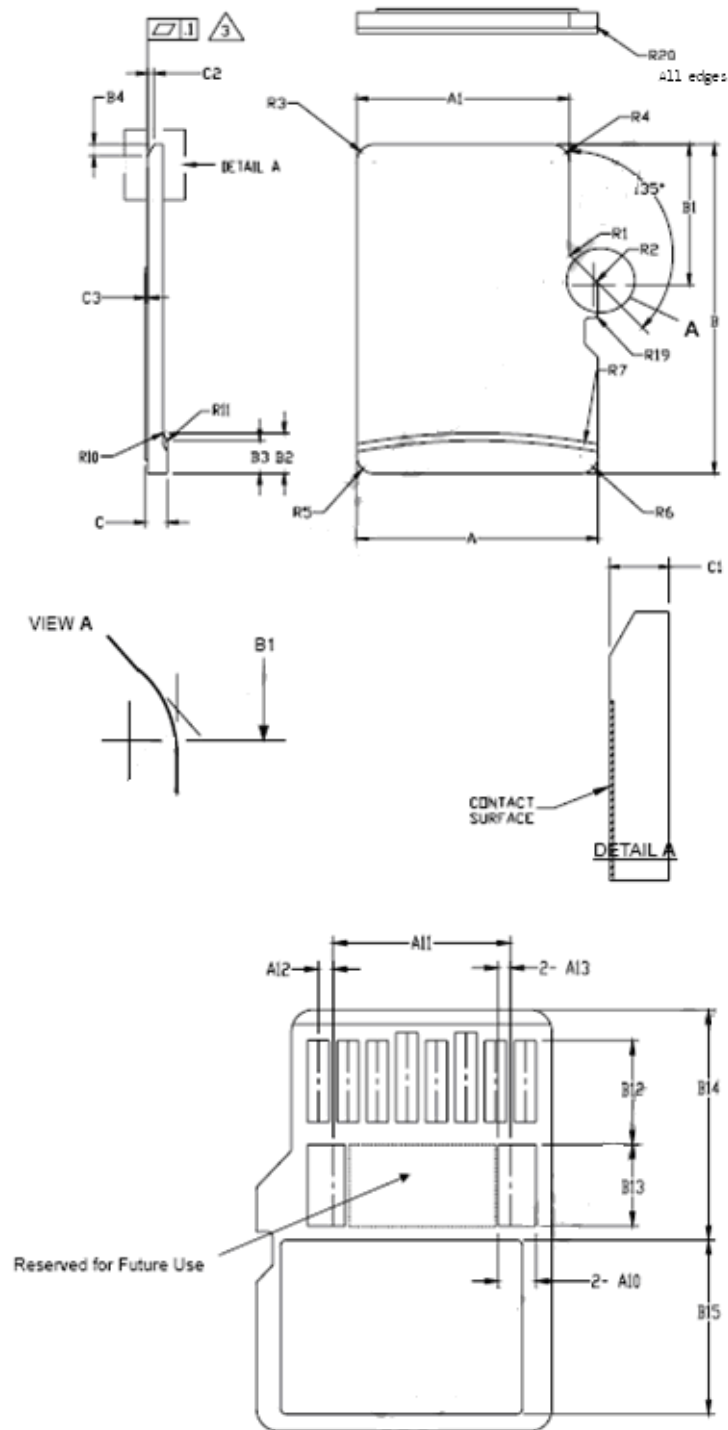

SYMBOL	COMMON DIMENSIONS			NOTE
	MIN	NOM	MAX	
A	10.90	11.00	11.10	
A1	9.60	9.70	9.80	
A2	-	3.85	-	BASIC
A3	7.60	7.70	7.80	
A4	-	1.10	-	BASIC
A5	0.75	0.80	0.85	
A6	-	-	8.50	
A7	0.90	-	-	
A8	0.60	0.70	0.80	
A9	0.80	-	-	
A10	1.35	1.40	1.45	
A11	6.50	6.60	6.70	
A12	0.50	0.55	0.60	
A13	0.40	0.45	0.50	
B	14.90	15.00	15.10	
B1	6.30	6.40	6.50	
B2	1.64	1.84	2.04	
B3	1.30	1.50	1.70	
B4	0.42	0.52	0.62	
B5	2.80	2.90	3.00	
B6	5.50	-	-	
B7	0.20	0.30	0.40	
B8	1.00	1.10	1.20	
B9	-	-	9.00	
B10	7.80	7.90	8.00	
B11	1.10	1.20	1.30	
B12	3.60	3.70	3.80	
B13	2.80	2.90	3.00	
B14	8.20	-	-	
B15	-	-	6.20	
C	0.90	1.00	1.10	
C1	0.60	0.70	0.80	
C2	0.20	0.30	0.40	
C3	0.00	-	0.15	
D1	1.00	-	-	
D2	1.00	-	-	
D3	1.00	-	-	
R1	0.20	0.40	0.60	
R2	0.20	0.40	0.60	
R3	0.70	0.80	0.90	
R4	0.70	0.80	0.90	
R5	0.70	0.80	0.90	
R6	0.70	0.80	0.90	
R7	29.50	30.00	30.50	
R10	-	0.20	-	
R11	-	0.20	-	
R17	0.10	0.20	0.30	
R18	0.20	0.40	0.60	
R19	0.05	-	0.20	
R20	0.02	-	0.15	

Notes:

1. DIMENSIONING AND TOLERANCING PER ASME Y14.5M-1994.
2. DIMENSIONS ARE IN MILLIMETERS.
3.  COPLANARITY IS ADDITIVE TO C1 MAX THICKNESS.

### 3.2 Durability Specifications

**Table 3-1** Durability Specifications

Item	Specifications
Temperature	-25°C to 85°C (Operating)
	-40°C to 85°C (Storage)
Shock	1,500G, 0.5ms
Vibration	20Hz~80Hz/1.52mm (frequency/displacement) 80Hz~2000Hz/20G (frequency/displacement) X, Y, Z axis/60mins each
Drop	150cm free fall, 6 face of each
Bending	≥ 10N, hold 1min/5times
Torque	0.1N-m or 2.5deg, hold 5min/5times
Salt Spray	Concentration: 3% NaCl at 35°C (storage for 24 hours)
Waterproof	JIS IPX7 compliance Water temperature 25°C Water depth: the lowest point of unit is locating 1000mm below surface (storage for 30 mins)
X-Ray Exposure	0.1 Gy of medium-energy radiation (70 KeV to 140 KeV, cumulative dose per year) to both sides of the card (storage for 30 mins)
Durability	10,000 times mating cycle
ESD	Pass

## 4. AC Characteristics

### 4.1 microSD Interface Timing (Default)

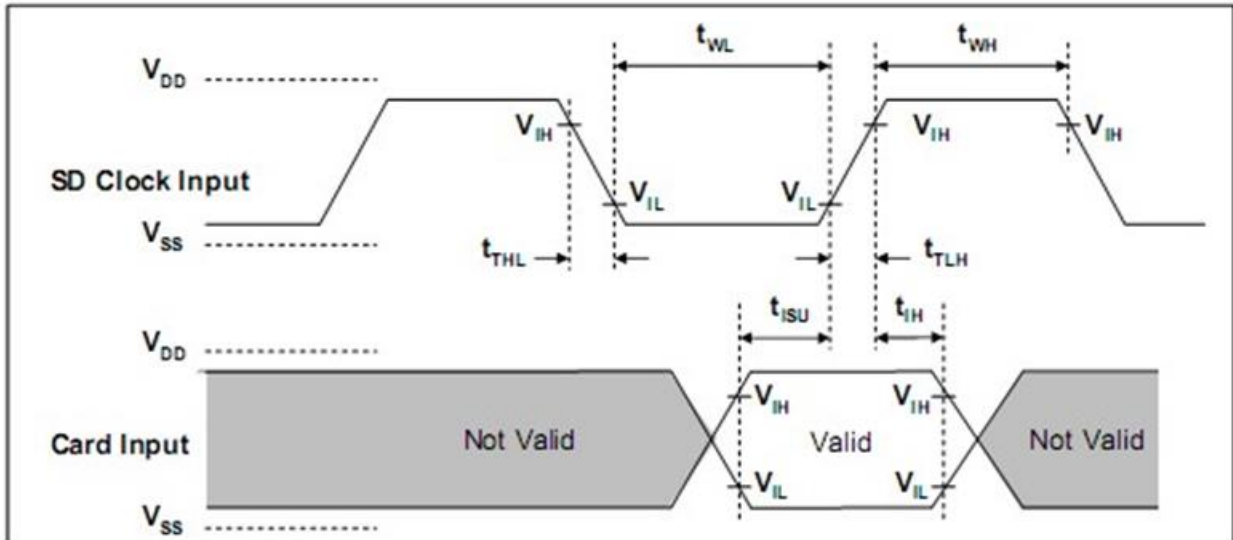

Card input Timing (Default Speed Card)

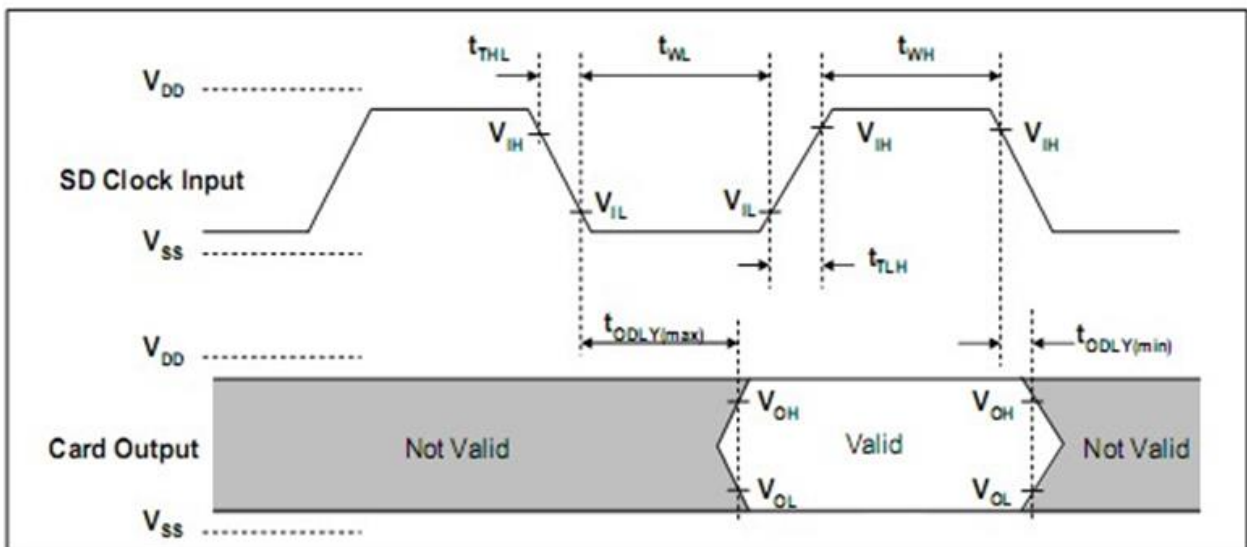

Card Output Timing (Default Speed Mode)

SYMBOL	PARAMETER	MIN	MAX	UNIT	REMARK
<b>Clock CLK (All values are referred to min(V<sub>IH</sub>) and max(V<sub>IL</sub>))</b>					
f <sub>PP</sub>	Clock frequency data transfer	0	25	MHz	C <sub>card</sub> ≤ 10 pF (1 card)
f <sub>OD</sub>	Clock frequency identification	0 <sup>(1)</sup> /100	400	KHz	C <sub>card</sub> ≤ 10 pF (1 card)
t <sub>WL</sub>	Clock low time	10	-	ns	C <sub>card</sub> ≤ 10 pF (1 card)
t <sub>WH</sub>	Clock high time	10	-	ns	C <sub>card</sub> ≤ 10 pF (1 card)
t <sub>TLH</sub>	Clock rise time	-	10	ns	C <sub>card</sub> ≤ 10 pF (1 card)
t <sub>THL</sub>	Clock fall time	-	10	ns	C <sub>card</sub> ≤ 10 pF (1 card)
<b>Inputs CMD, DAT (Referenced to CLK)</b>					
t <sub>ISU</sub>	Input setup time	5	-	ns	C <sub>card</sub> ≤ 10 pF (1 card)
t <sub>IH</sub>	Input hold time	5	-	ns	C <sub>card</sub> ≤ 10 pF (1 card)
<b>Outputs CMD, DAT (Referenced to CLK)</b>					
t <sub>ODLY</sub>	Output delay time during data transfer mode	0	14	ns	C <sub>L</sub> ≤ 40 pF (1 card)
t <sub>OH</sub>	Output hold time	0	50	ns	C <sub>L</sub> ≤ 40 pF (1 card)

(1)0Hz means to stop the clock. The given minimum frequency range is for cases that require the clock to be continued.

## 4.2 microSD Interface Timing (High Speed Mode)

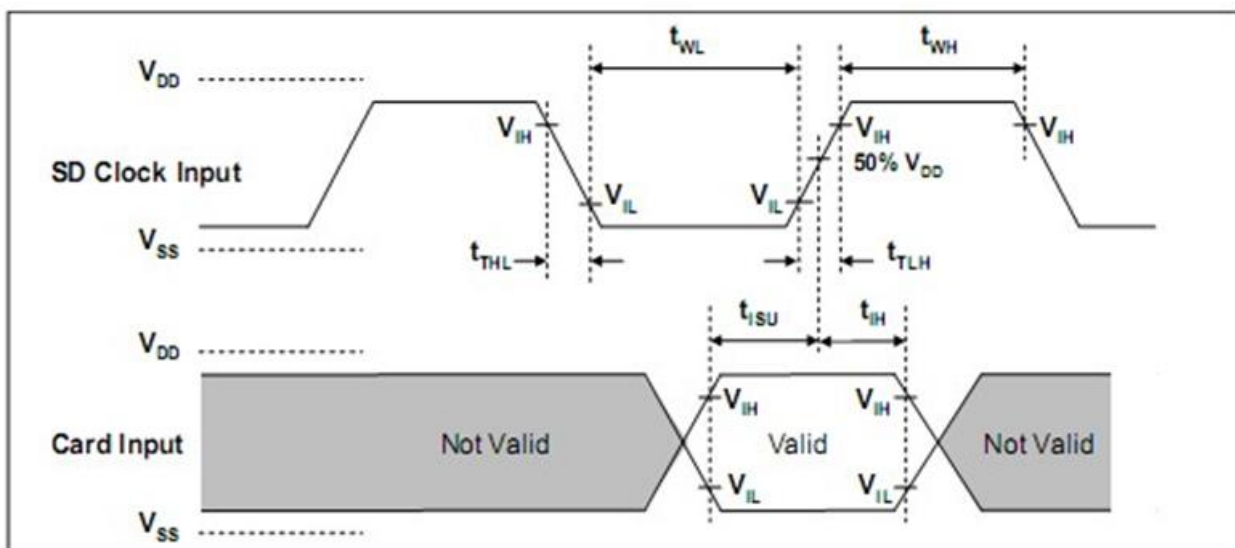

**Card Input Timing (High Speed Card)**

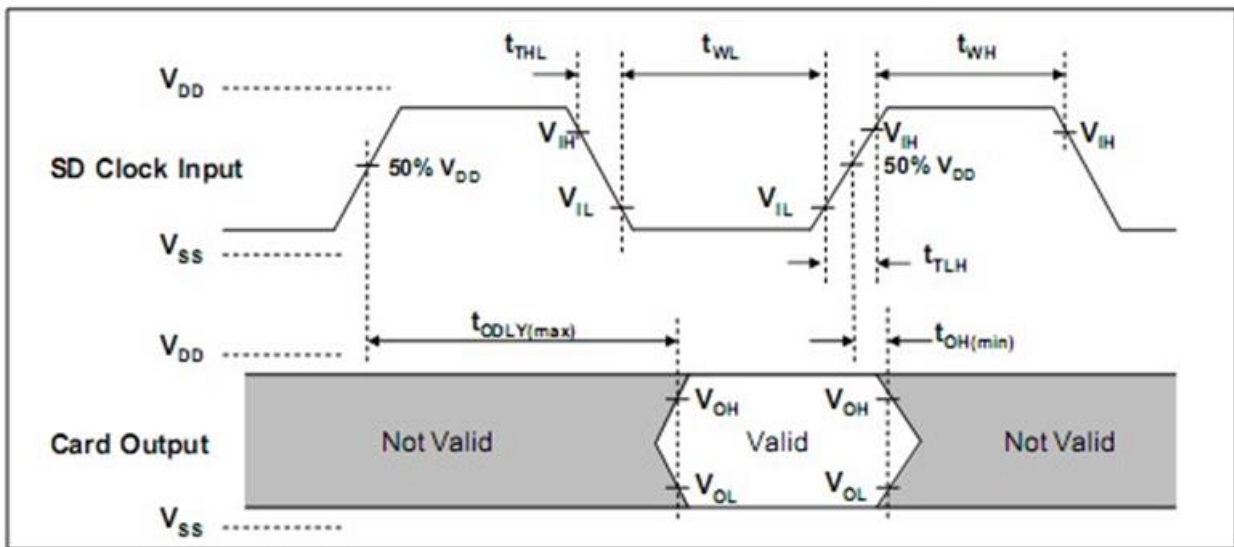

**Card Output Timing (High Speed Mode)**

SYMBOL	PARAMETER	MIN	MAX	UNIT	REMARK
<b>Clock CLK (All values are referred to min(V<sub>IH</sub>) and max(V<sub>IL</sub>))</b>					
f <sub>PP</sub>	Clock frequency data transfer	0	50	MHz	C <sub>card</sub> ≤ 10 pF (1 card)
t <sub>WL</sub>	Clock low time	7	-	ns	C <sub>card</sub> ≤ 10 pF (1 card)
t <sub>WH</sub>	Clock high time	7	-	ns	C <sub>card</sub> ≤ 10 pF (1 card)
t <sub>TLH</sub>	Clock rise time	-	3	ns	C <sub>card</sub> ≤ 10 pF (1 card)
t <sub>THL</sub>	Clock fall time	-	3	ns	C <sub>card</sub> ≤ 10 pF (1 card)
<b>Inputs CMD, DAT (Referenced to CLK)</b>					
t <sub>ISU</sub>	Input setup time	6	-	ns	C <sub>card</sub> ≤ 10 pF (1 card)
t <sub>IH</sub>	Input hold time	2	-	ns	C <sub>card</sub> ≤ 10 pF (1 card)
<b>Outputs CMD, DAT (Referenced to CLK)</b>					
t <sub>ODLY</sub>	Output delay time during data transfer made	-	14	ns	CL ≤ 40 pF (1 card)
t <sub>OH</sub>	Output hold time	2.5	-	ns	CL ≥ 15 pF (1 card)
CL	Total system capacitance for each line*	-	40	pF	1 card

\*In order to satisfy severe timing, host shall run on only one card

### 4.3 microSD Interface Timing (SDR12, SDR25, SDR50 and SDR104 Modes)

#### 4.3.1 Clock Timing

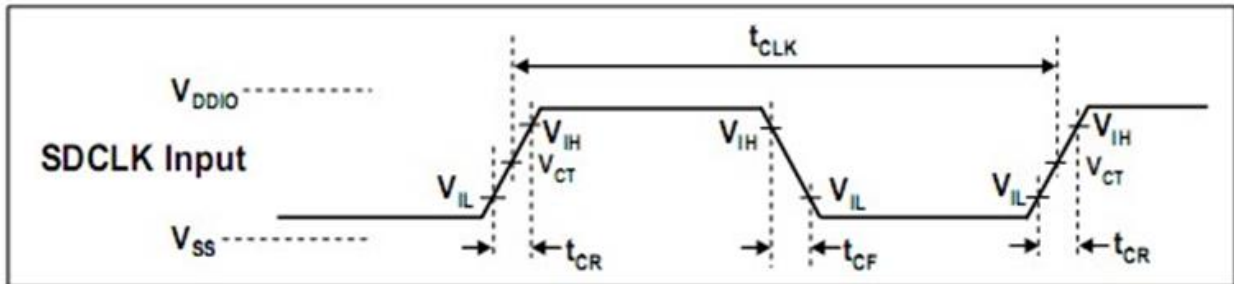

**Clock Signal Timing**

SYMBOL	MIN	MAX	UNIT	REMARK
$t_{CLK}$	4.8	-	ns	208MHz (Max.), Between rising edge, $V_{CT} = 0.975V$
$t_{CR}, t_{CF}$	-	$0.2 * t_{CLK}$	ns	$t_{CR}, t_{CF} < 2.00ns$ (max.) at 208MHz, $C_{CARD}=10pF$ $t_{CR}, t_{CF} < 2.00ns$ (max.) at 100MHz, $C_{CARD}=10pF$ The absolute maximum value of $t_{CR}, t_{CF}$ is 10ns regardless of clock frequency.
Clock Duty	30	70	%	

#### 4.3.2 Card Input Timing

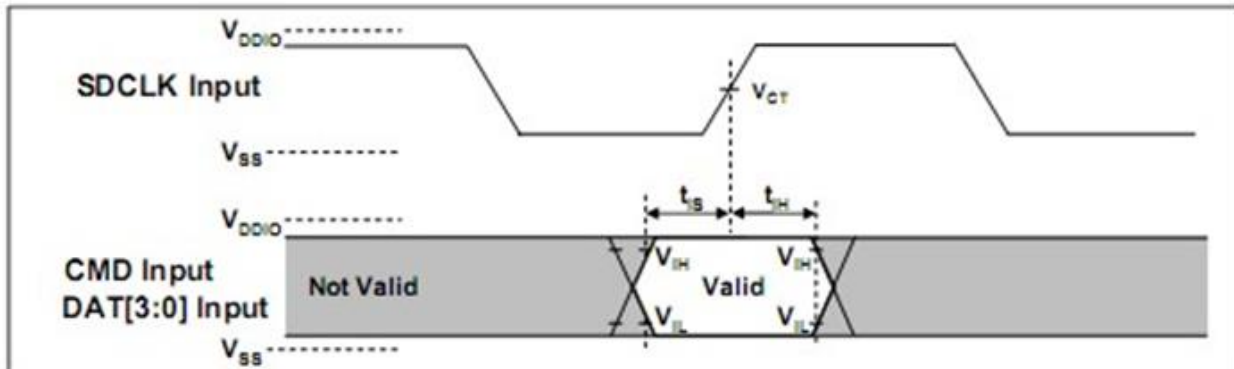

**Card Input Timing**

SYMBOL	MIN	MAX	UNIT	SDR104 MODE
$t_{IS}$	1.40	-	ns	$C_{CARD} = 10pF, V_{CT} = 0.975V$
$t_{IH}$	0.80	-	ns	$C_{CARD} = 5pF, V_{CT} = 0.975V$
SYMBOL	MIN	MAX	UNIT	SDR12, SDR25 and SDR50 MODES
$t_{IS}$	3.00	-	ns	$C_{CARD} = 10pF, V_{CT} = 0.975V$
$t_{IH}$	0.80	-	ns	$C_{CARD} = 5pF, V_{CT} = 0.975V$

### 4.3.3 Card Output Timing of Fixed Data Window (SDR12, SDR25 and SDR50)

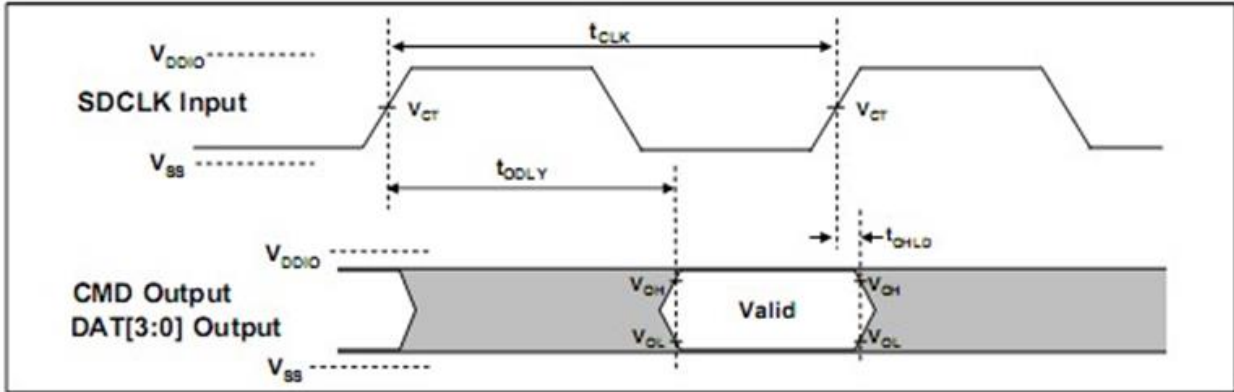

Output Timing of Fixed Date Window<sup>+</sup>

SYMBOL	MIN	MAX	UNIT	REMARK
$t_{ODLY}$	-	7.5	ns	$t_{CLK} \geq 10.0ns$ , $CL=30pF$ , using driver Type B, for SDR50.
$t_{ODLY}$		14	ns	$t_{CLK} \geq 20.0ns$ , $CL=40pF$ , using driver Type B, for SDR25 and SDR12.
$t_{OH}$	1.5	-	ns	Hold time at the $t_{ODLY}$ (min.). $CL=15pF$

### 4.3.4 Output Timing of Variable Window (SDR104)

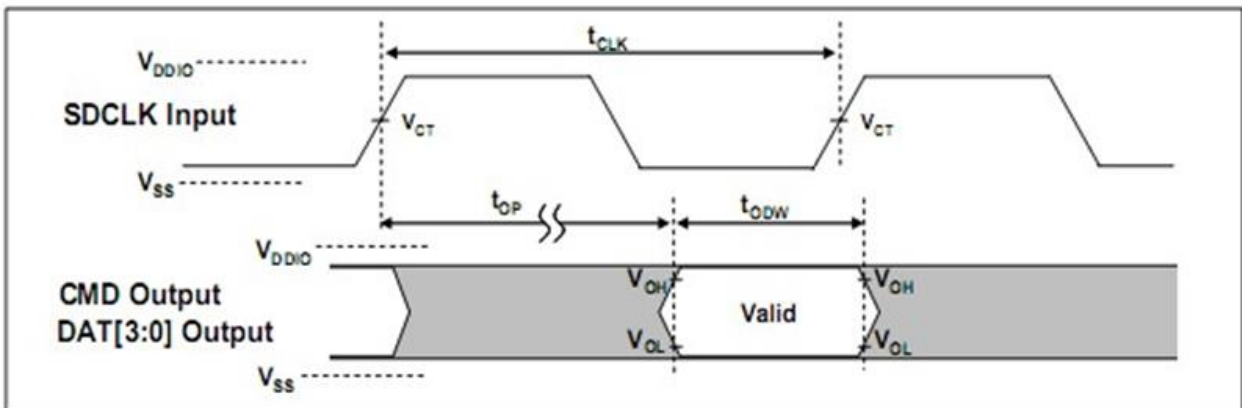

Output Timing of Variable Data Window<sup>+</sup>

SYMBOL	MIN	MAX	UNIT	REMARK
$t_{OP}$	-	2	UI	Card Output Phase
$\Delta t_{OP}$	-350	+1550	ps	Delay variation due to temperature change after tuning
$t_{ODW}$	0.60	-	UI	$t_{ODW} = 2.88ns$ at 208MHz

### 4.3.5 SD Interface Timing (DDR50 Mode)

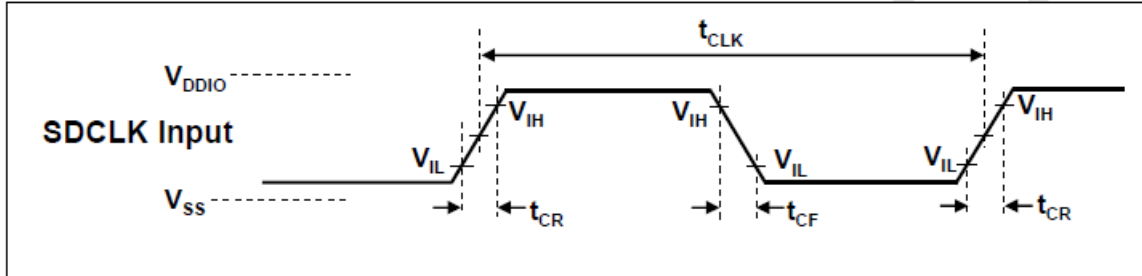

#### Clock Signal Timing

SYMBOL	MIN	MAX	UNIT	REMARK
$t_{CLK}$	20	-	ns	50MHz (Max.), Between rising edge
$t_{CR}, t_{CF}$	-	$0.2 \cdot t_{CLK}$	ns	$t_{CR}, t_{CF} < 4.00\text{ns (max.)}$ at 50MHz, CCARD=10pF
Clock Duty	45	55	%	

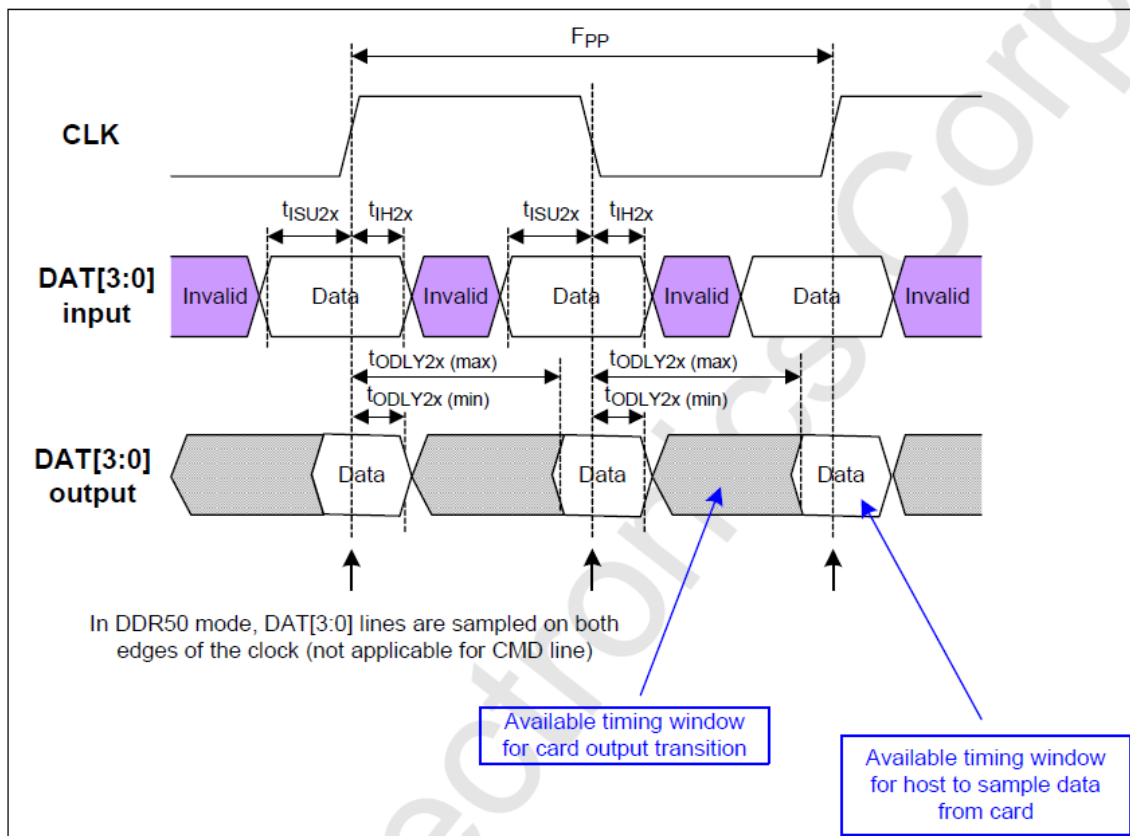

Timing Diagram DAT Inputs/Outputs Referenced to CLK in DDR50 Mode

### 4.3.6 Bus Timings – Parameters Values (DDR50 Mode)

Symbol	Parameters	Min	Max	Unit	Remark
<b>Input CMD</b> (referenced to CLK rising edge)					
t <sub>ISU</sub>	Input set-up time	6	-	ns	C <sub>card</sub> ≤ 10 pF (1 card)
t <sub>IH</sub>	Input hold time	0.8	-	ns	C <sub>card</sub> ≤ 10 pF (1 card)
<b>Output CMD</b> (referenced to CLK rising edge)					
t <sub>ODLY</sub>	Output Delay time during Data Transfer Mode	-	13.7	ns	C <sub>L</sub> ≤ 30 pF (1 card)
T <sub>OH</sub>	Output Hold time	1.5	-	ns	C <sub>L</sub> ≥ 15 pF (1 card)
<b>Inputs DAT</b> (referenced to CLK rising and falling edges)					
t <sub>ISU2x</sub>	Input set-up time	3	-	ns	C <sub>card</sub> ≤ 10 pF (1 card)
t <sub>IH2x</sub>	Input hold time	0.8	-	ns	C <sub>card</sub> ≤ 10 pF (1 card)
<b>Outputs DAT</b> (referenced to CLK rising and falling edges)					
t <sub>ODLY2x</sub>	Output Delay time during Data Transfer Mode	-	7.0	ns	C <sub>L</sub> ≤ 25 pF (1 card)
T <sub>OH2x</sub>	Output Hold time	1.5	-	ns	C <sub>L</sub> ≥ 15 pF (1 card)

## 5. Product Ordering Information

### 5.1 Product Code Designations

Code	1	2	3	4	5	6	7	8	9	10	11	12	13	14	15	16
	A	K	6	.	8	4	8	X	S	A	.	0	0	1	0	1

<b>Code 1-3 (Product Line &amp; form factor)</b>	CV210-MSD
<b>Code 5-6 (Model/Solution)</b>	CV210
<b>Code 7-8 (Product Capacity)</b>	8G:16GB 8H:32GB 8J:64GB
<b>Code 9 (Flash Type &amp; Product Temp)</b>	S: 3D SLC-liteX Standard Temperature
<b>Code 10 (Product Spec)</b>	A: microSD Card
<b>Code 12-14 (Version Number)</b>	Random numbers generated by system
<b>Code 15-16 (Firmware Version)</b>	01: Firmware page mode

## 5.2 Valid Combinations

Capacity	Part Number
16GB	AK6.848GSA.00101
32GB	AK6.848HSA.00101
64GB	AK6.848JSA.00101

**Note:** Valid combinations are those products in mass production or will be in mass production. Consult your Apacer sales representative to confirm availability of valid combinations and to determine availability of new combinations.

## Revision History

Revision	Description	Date
1.0	Initial release	6/9/2021

## Global Presence

### Taiwan (Headquarters)

#### Apacer Technology Inc.

1F., No.32, Zhongcheng Rd., Tucheng Dist.,  
New Taipei City 236, Taiwan R.O.C.  
Tel: 886-2-2267-8000  
Fax: 886-2-2267-2261  
[amtsales@apacer.com](mailto:amtsales@apacer.com)

### Japan

#### Apacer Technology Corp.

6F, Daiyontamachi Bldg., 2-17-12, Shibaura, Minato-Ku,  
Tokyo, 108-0023, Japan  
Tel: 81-3-5419-2668  
Fax: 81-3-5419-0018  
[jpservices@apacer.com](mailto:jpservices@apacer.com)

### China

#### Apacer Electronic (Shanghai) Co., Ltd

Room D, 22/FL, No.2, Lane 600, JieyunPlaza,  
Tianshan RD, Shanghai, 200051, China  
Tel: 86-21-6228-9939  
Fax: 86-21-6228-9936  
[sales@apacer.com.cn](mailto:sales@apacer.com.cn)

### U.S.A.

#### Apacer Memory America, Inc.

46732 Lakeview Blvd., Fremont, CA 94538  
Tel: 1-408-518-8699  
Fax: 1-510-249-9551  
[sa@apacerus.com](mailto:sa@apacerus.com)

### Europe

#### Apacer Technology B.V.

Science Park Eindhoven 5051 5692 EB Son,  
The Netherlands  
Tel: 31-40-267-0000  
Fax: 31-40-290-0686  
[sales@apacer.nl](mailto:sales@apacer.nl)

### India

#### Apacer Technologies Pvt Ltd,

1874, South End C Cross, 9<sup>th</sup> Block Jayanagar,  
Bangalore-560069, India  
Tel: 91-80-4152-9061/62  
Fax: 91-80-4170-0215  
[sales\\_india@apacer.com](mailto:sales_india@apacer.com)