

*RoHS Recast Compliant*

# **Industrial MicroSD 3.0**

*H1 Product Specifications*

**October 3, 2016**

*Version 1.1*



**Apacer Technology Inc.**

1F, No.32, Zhongcheng Rd., Tucheng Dist., New Taipei City, Taiwan, R.O.C

Tel: +886-2-2267-8000 Fax: +886-2-2267-2261

[www.apacer.com](http://www.apacer.com)

## FEATURES:

- **Fully Compatible with SD Card Specifications 3.0, 2.0 and 1.1**
  - Part 1, Physical Layer Specification, Ver 3.01 Final
  - Part 2, File System Specification, Ver 3.00
  - Part 3, Security Specification, Ver 3.00 Final
- **Capacity**
  - 256 MB, 512 MB, 1 GB, 2 GB
- **Performance\***
  - Sustained Read: Up to 20 MB/sec
  - Sustained Write: Up to 16 MB/sec
- **Non-UHS Bus Speed Mode**
- **SD-Protocol Compatible**
- **Supports SD SPI Mode**
- **NAND Flash Type: SLC**
- **Flash Management**
  - Bad block management
  - Built-in advanced ECC algorithms
  - S.M.A.R.T.
  - Wear-leveling algorithms
  - Auto-read refresh
  - Power failure management
- **Temperature Range**
  - Operating temperature:  
Standard: -25°C to 85°C  
Extended: -40°C to 85°C
  - Storage temperature: -40°C to 85°C
- **Operating Voltage: 2.7V ~ 3.6V**
- **Power Consumption\***
  - Operating: 60 mA
  - Standby: 100  $\mu$ A
- **Dimensions: 15mm(L) x 11mm(W) x 1mm(H)**
- **RoHS Recast Compliant (2011/65/EU)**

\*Performance values presented here are typical and may vary depending on settings and platforms.

## TABLE OF CONTENTS

<b>1. General Description</b> .....	<b>3</b>
1.1 Product Function Block .....	3
1.2 Functional Description .....	4
1.2.1 Bad Block Management .....	4
1.2.2 ECC Algorithms .....	4
1.2.3 S.M.A.R.T. ....	4
1.2.4 Wear Leveling .....	4
1.2.5 Auto-Read Refresh .....	5
1.2.6 Power Failure Management .....	5
<b>2. Electrical Characteristics</b> .....	<b>6</b>
2.1 Card Architecture .....	6
2.2 Pin Assignment .....	6
2.3 Capacity Specifications .....	7
2.4 Performance Specifications .....	7
2.5 Electrical Specifications .....	7
<b>3. Physical Characteristics</b> .....	<b>8</b>
3.1 Physical Dimensions .....	8
3.2 Durability Specifications .....	10
<b>4. AC Characteristics</b> .....	<b>11</b>
4.1 MicroSD Interface Timing (Default) .....	11
4.2 MicroSD Interface Timing (High Speed Mode) .....	12
4.3 MicroSD Interface Timing (SDR12, SDR25, SDR50 and SDR104 Modes) Input .....	14
4.3.1 Clock Timing .....	14
4.3.2 Card Input Timing .....	14
4.3.3 Card Output Timing of Fixed Data Window (SDR12, SDR25 and SDR50) .....	15
4.3.4 Output Timing of Variable Window (SDR104) .....	15
4.3.5 SD Interface Timing (DDR50 Mode) .....	16
4.3.6 Bus Timings – Parameters Values (DDR50 Mode) .....	17
<b>5. Product Ordering Information</b> .....	<b>18</b>
5.1 Product Code Designations .....	18
5.2 Valid Combinations .....	19

# 1. General Description

The Micro Secure Digital (MicroSD) card is fully compliant to the specification released by SD Card Association. The Command List supports [Part 1 Physical Layer Specification Ver3.01 Final] definitions. Card Capacity of Non-secure Area, Secure Area Supports [Part 3 Security Specification Ver3.00 Final] Specifications.

The MicroSD card comes with 8-pin interface, designed to operate at optimal performance. It can alternate communication protocol between the SD mode and SPI mode. It performs data error detection and correction with very low power consumption.

Apacer Industrial Micro Secure Digital card is ideal for its high performance, good reliability and wide compatibility. Not to mention that it's well adapted for hand-held applications in semi-industrial/medical markets already. The new MicroSD card is capable of delivering better performance and P/E cycles.

## 1.1 Product Function Block

The MicroSD contains a card controller and a memory core for the SD standard interface.

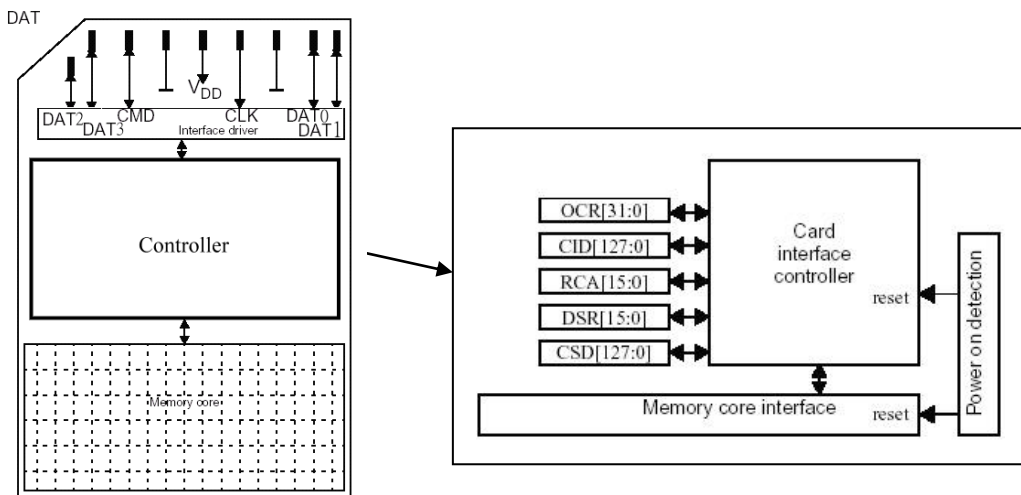

---

## 1.2 Functional Description

---

The MicroSD device contains a high level, intelligent flash management that provides many capabilities including:

- Bad block management
- ECC algorithms
- S.M.A.R.T.
- Wear leveling algorithms
- Auto-read refresh

### 1.2.1 Bad Block Management

The SD controller contains logic/physical flash block mapping and bad block management system. It will manage all flash block including user data space and spare block.

The MicroSD also contains a sophisticated defect and error management system. It does a read after write under margin conditions to verify that the data is written correctly (except in the case of write pre-erased sectors). In case that a bit is found to be defective, the SD will replace this bad bit with a spare bit within the sector header. If necessary, the MicroSD will even replace the entire sector with a spare sector. This is completely transparent to the master (host device) and does not consume any user data space.

### 1.2.2 ECC Algorithms

The powerful ECC algorithms will enhance flash block use rate and whole device life. The SD controller supports up to 68bits ECC circuits to protect data transfer.

### 1.2.3 S.M.A.R.T.

S.M.A.R.T. (SMART), an acronym stands for Self-Monitoring, Analysis and Reporting Technology, is an open standard allowing an individual disk drive in the ATA/IDE or SCSI interface to automatically monitor its own health and report potential problems in order to prevent data loss. This failure warning technology provides predictions from unscheduled downtime by observing and storing critical drive performance and calibration parameters. Ideally, this should allow taking hands-on actions to keep from impending drive failure.

Failures are divided into two categories: those that can be predicted and those that cannot. Predictable failures occur gradually over time, and the decline in performance can be detected; on the other hand, unpredictable failures happen very sudden without any warning. These failures may be caused by power surges or related to electronic components. The purpose of the SMART implementation is to predict near-term failures of each individual disk drive and generate a warning to prevent unfortunate loss.

### 1.2.4 Wear Leveling

NAND Flash devices can only undergo a limited number of program/erase cycles, and in most cases, the flash media are not used evenly. If some area get updated more frequently than others, the lifetime of the device would be reduced significantly. Thus, Wear Leveling technique is applied to extend the lifespan of NAND Flash by evenly distributing write and erase cycles across the media.

Apacer provides wear leveling algorithm, which can efficiently spread out the flash usage through the whole flash media area. Moreover, by implementing both dynamic and static Wear Leveling algorithms, the life expectancy of the NAND Flash is greatly improved.

---

### **1.2.5 Auto-Read Refresh**

When continuously being read, NAND flash memory cannot engage wear leveling since this applies while writing data. Subsequently, errors aggregated over time and become uncorrectable. To keep errors from going beyond ECC's capability to recover and memory blocks in good hands, Apacer's Auto-Read Refresh will spontaneously refresh the bit errors when the threshold is triggered by the error count in a block.

### **1.2.6 Power Failure Management**

Apacer industrial SD and MicroSD cards provide complete data protection mechanism during every abnormal power shutdown situation, such as power failure at programming data, updating system tables, erasing blocks, etc. Apacer Power-Loss Protection mechanism includes:

- Maintaining data correctness and increasing the reliability of the data stored in the NAND Flash memory.
- Protecting F/W table and the data written to flash from data loss in the event of power off.
- The data written at the exact moment power off will be lost, and the max data loss is 16 sectors.

## 2. Electrical Characteristics

### 2.1 Card Architecture

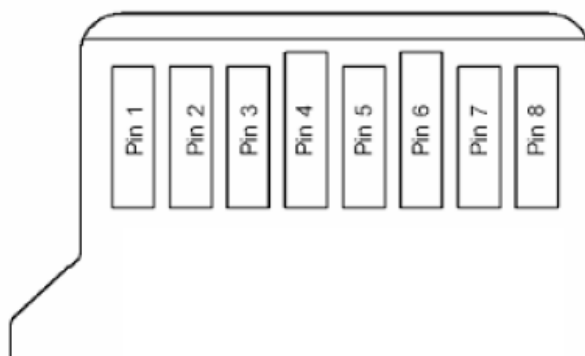

### 2.2 Pin Assignment

Pin	SD Mode		SPI Mode	
	Name	Description	Name	Description
1	DAT2	Data Line[Bit 2]	RSV	Reserved
2	CD/DAT3	Card Detect/Data Line[Bit 3]	CS	Chip Select (neg true)
3	CMD	Command/Response	DI	Data In
4	VDD	Supply Voltage	VDD	Supply Voltage
5	CLK	Clock	SCLK	Clock
6	VSS	Supply Voltage Ground	VSS	Supply Voltage Ground
7	DAT0	Data Line[Bit 0]	DO	Data Out
8	DAT1	Data Line[Bit 1]	RSV	Reserved

## 2.3 Capacity Specifications

The following table shows the specific capacity for the SD card.

Capacity	Total Bytes
256 MB	248,643,584
512 MB	497,287,168
1 GB	996,868,096
2 GB	1,980,432,384

Note: Total bytes are viewed under Windows operating system and were measured by SD format too.

## 2.4 Performance Specifications

Performance of the SD card is shown in the table below.

Modes \ Capacity	256 MB	512 MB	1 GB	2 GB
	Read (MB/s)	15	20	19
Write (MB/s)	9	15	16	15

Note: Results may vary depending on settings and platforms.

## 2.5 Electrical Specifications

### Operating Voltage

Symbol	Parameter	Min.	Max.	Unit
$V_{DD}$	Power Supply Voltage	2.7	3.6	V

### Power Consumption

Modes \ Capacity	256 MB	512 MB	1 GB	2 GB
	Operating (mA)	50	55	60
Standby ( $\mu$ A)	80	85	90	100

Note: Results may vary depending on settings and platforms.

### 3. Physical Characteristics

#### 3.1 Physical Dimensions

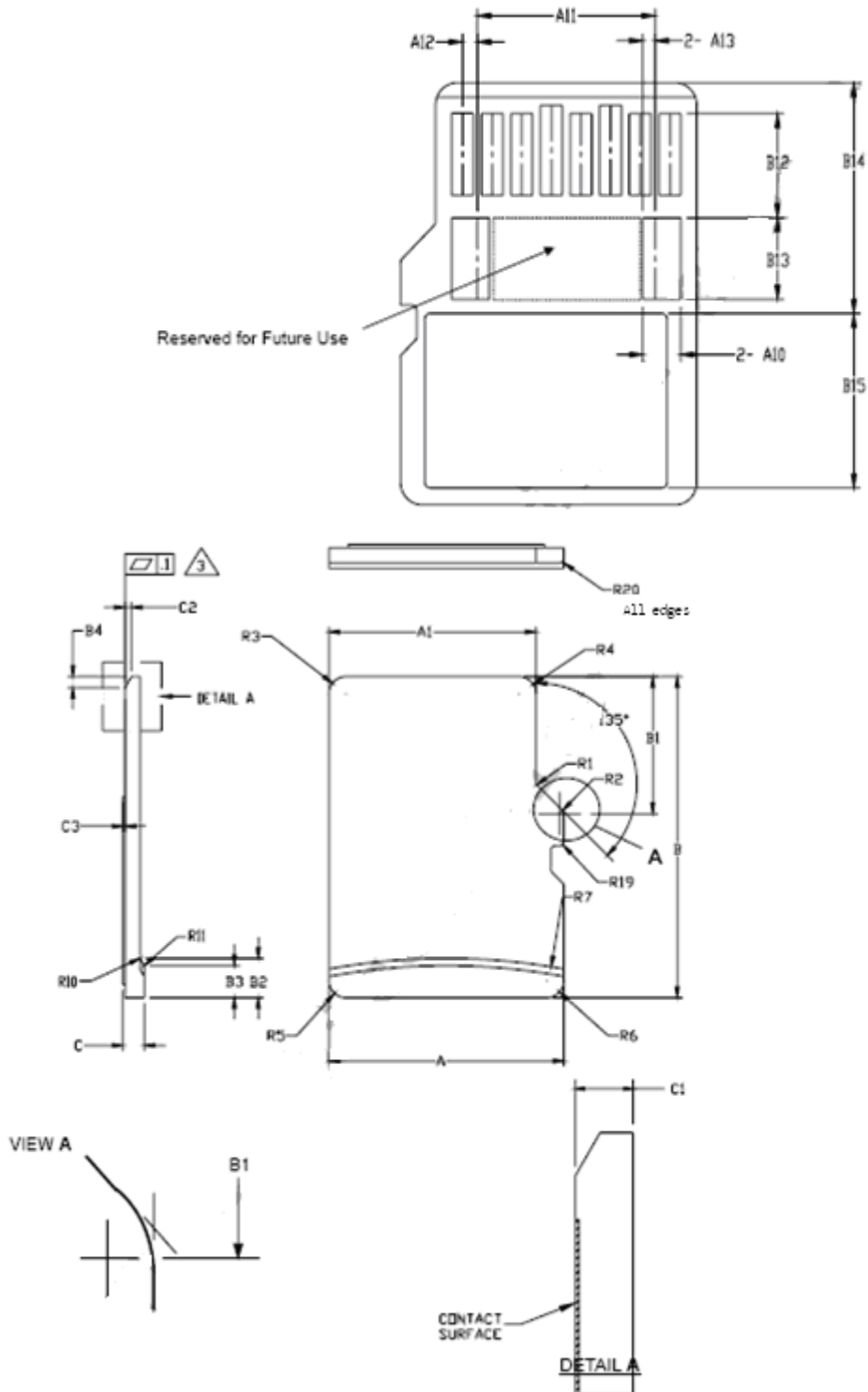

# Industrial MicroSD 3.0 AP-MSDxxxXB-1BT

SYMBOL	COMMON DIMENSIONS			NOTE
	MIN	NOM	MAX	
A	10.90	11.00	11.10	
A1	9.60	9.70	9.80	
A2	-	3.85	-	BASIC
A3	7.60	7.70	7.80	
A4	-	1.10	-	BASIC
A5	0.75	0.80	0.85	
A6	-	-	8.50	
A7	0.90	-	-	
A8	0.60	0.70	0.80	
A9	0.80	-	-	
A10	1.35	1.40	1.45	
A11	6.50	6.60	6.70	
A12	0.50	0.55	0.60	
A13	0.40	0.45	0.50	
B	14.90	15.00	15.10	
B1	6.30	6.40	6.50	
B2	1.64	1.84	2.04	
B3	1.30	1.50	1.70	
B4	0.42	0.52	0.62	
B5	2.80	2.90	3.00	
B6	5.50	-	-	
B7	0.20	0.30	0.40	
B8	1.00	1.10	1.20	
B9	-	-	9.00	
B10	7.80	7.90	8.00	
B11	1.10	1.20	1.30	
B12	3.60	3.70	3.80	
B13	2.80	2.90	3.00	
B14	8.20	-	-	
B15	-	-	6.20	
C	0.90	1.00	1.10	
C1	0.60	0.70	0.80	
C2	0.20	0.30	0.40	
C3	0.00	-	0.15	
D1	1.00	-	-	
D2	1.00	-	-	
D3	1.00	-	-	
R1	0.20	0.40	0.60	
R2	0.20	0.40	0.60	
R3	0.70	0.80	0.90	
R4	0.70	0.80	0.90	
R5	0.70	0.80	0.90	
R6	0.70	0.80	0.90	
R7	29.50	30.00	30.50	
R10	-	0.20	-	
R11	-	0.20	-	
R17	0.10	0.20	0.30	
R18	0.20	0.40	0.60	
R19	0.05	-	0.20	
R20	0.02	-	0.15	

Notes:

1. DIMENSIONING AND TOLERANCING PER ASME Y14.5M-1994.
2. DIMENSIONS ARE IN MILLIMETERS.
3.  COPLANARITY IS ADDITIVE TO C1 MAX THICKNESS.

## 3.2 Durability Specifications

Item	Specifications
Temperature	-25°C to 85°C (Standard) -40°C to 85°C (Extended)
	-40°C to 85°C (Storage)
Shock	1,500G, 0.5ms
Vibration	20Hz~80Hz/1.52mm (frequency/displacement) 80Hz~2000Hz/20G (frequency/displacement) X, Y, Z axis/60mins each
Drop	150cm free fall, 6 face of each
Bending	≥ 10N, hold 1min/5times
Torque	0.1N-m or 2.5deg, hold 5min/5times
Salt spray	Concentration: 3% NaCl at 35°C (storage for 24 hours)
Waterproof	JIS IPX7 compliance Water temperature 25°C Water depth: the lowest point of unit is locating 1000mm below surface (storage for 30 mins)
X-Ray Exposure	0.1 Gy of medium-energy radiation (70 KeV to 140 KeV, cumulative dose per year) to both sides of the card (storage for 30 mins)
Durability	10,000 times mating cycle
ESD	Pass

## 4. AC Characteristics

### 4.1 MicroSD Interface Timing (Default)

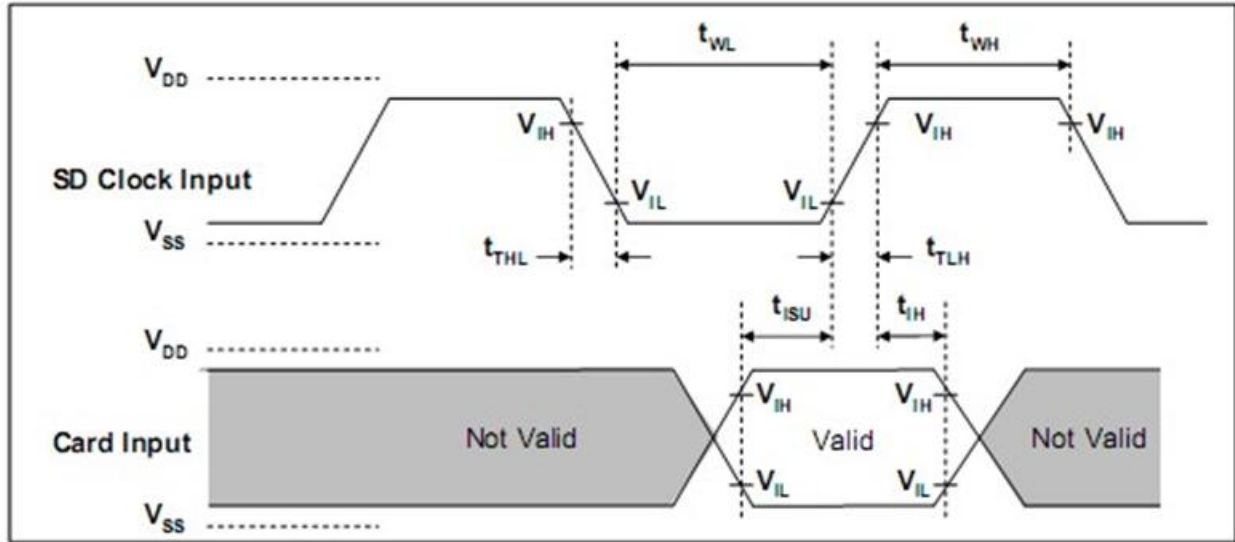

Card input Timing (Default Speed Card)

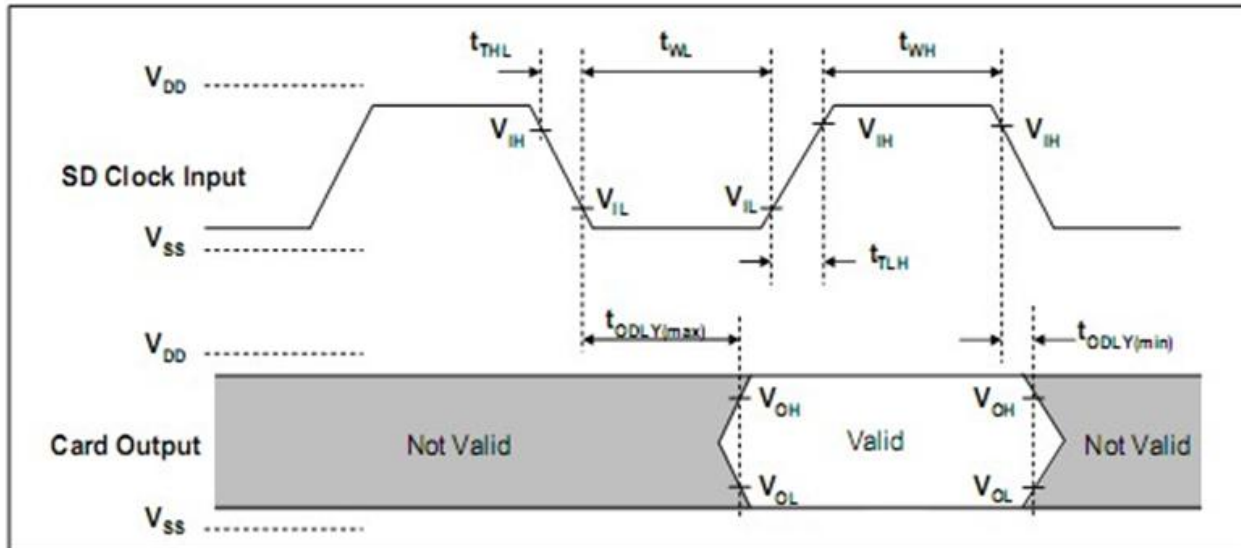

Card Output Timing (Default Speed Mode)

SYMBOL	PARAMETER	MIN	MAX	UNIT	REMARK
<b>Clock CLK (All values are referred to min(V<sub>IH</sub>) and max(V<sub>IL</sub>))</b>					
f <sub>PP</sub>	Clock frequency data transfer	0	25	MHz	C <sub>card</sub> ≤ 10 pF (1 card)
f <sub>OD</sub>	Clock frequency identification	0 <sup>(1)</sup> /100	400	KHz	C <sub>card</sub> ≤ 10 pF (1 card)
t <sub>WL</sub>	Clock low time	10	-	ns	C <sub>card</sub> ≤ 10 pF (1 card)
t <sub>WH</sub>	Clock high time	10	-	ns	C <sub>card</sub> ≤ 10 pF (1 card)
t <sub>TLH</sub>	Clock rise time	-	10	ns	C <sub>card</sub> ≤ 10 pF (1 card)
t <sub>THL</sub>	Clock fall time	-	10	ns	C <sub>card</sub> ≤ 10 pF (1 card)
<b>Inputs CMD, DAT (Referenced to CLK)</b>					
t <sub>ISU</sub>	Input setup time	5	-	ns	C <sub>card</sub> ≤ 10 pF (1 card)
t <sub>IH</sub>	Input hold time	5	-	ns	C <sub>card</sub> ≤ 10 pF (1 card)
<b>Outputs CMD, DAT (Referenced to CLK)</b>					
t <sub>ODLY</sub>	Output delay time during data transfer mode	0	14	ns	C <sub>L</sub> ≤ 40 pF (1 card)
t <sub>OH</sub>	Output hold time	0	50	ns	C <sub>L</sub> ≤ 40 pF (1 card)

(1)0Hz means to stop the clock. The given minimum frequency range is for cases that require the clock to be continued.

## 4.2 MicroSD Interface Timing (High Speed Mode)

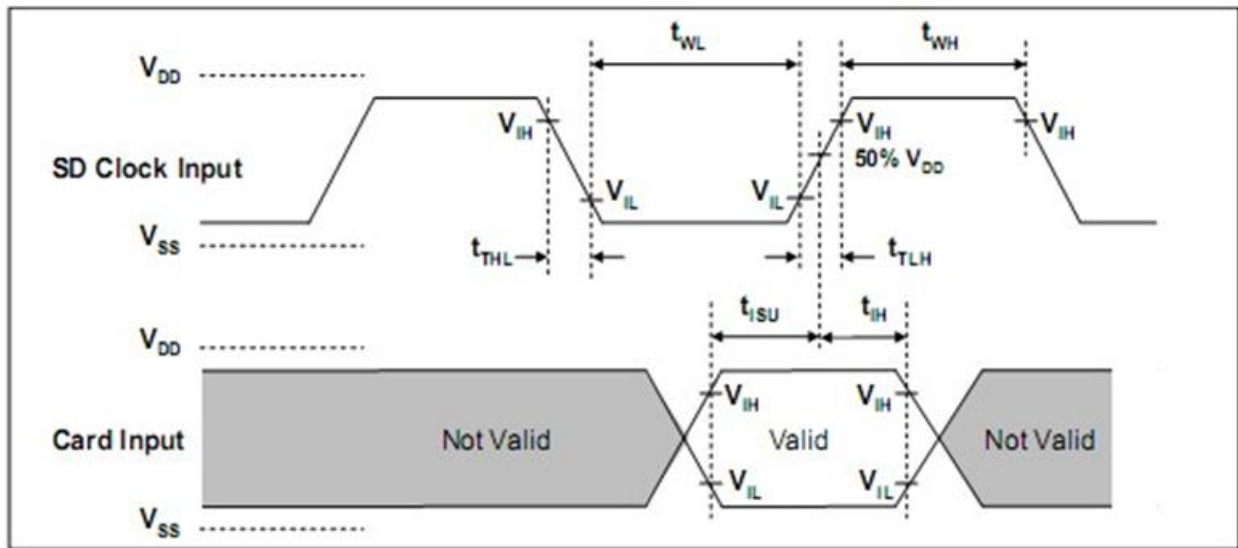

**Card Input Timing (High Speed Card)**

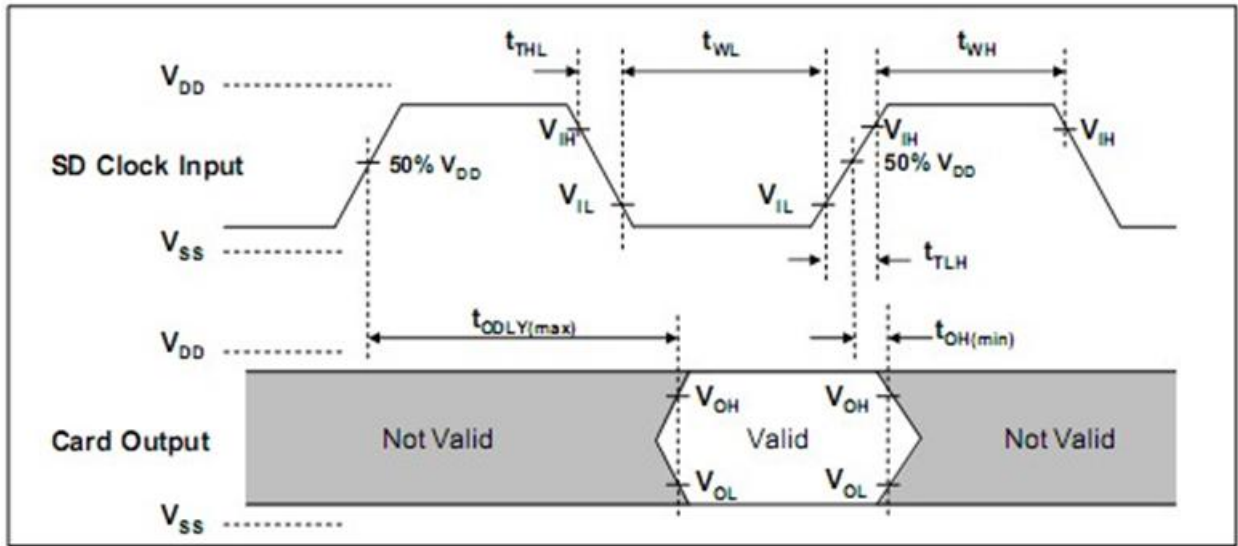

**Card Output Timing (High Speed Mode)**

SYMBOL	PARAMETER	MIN	MAX	UNIT	REMARK
<b>Clock CLK (All values are referred to min(V<sub>IH</sub>) and max(V<sub>IL</sub>))</b>					
f <sub>PP</sub>	Clock frequency data transfer	0	50	MHz	C <sub>card</sub> ≤ 10 pF (1 card)
t <sub>WL</sub>	Clock low time	7	-	ns	C <sub>card</sub> ≤ 10 pF (1 card)
t <sub>WH</sub>	Clock high time	7	-	ns	C <sub>card</sub> ≤ 10 pF (1 card)
t <sub>TLH</sub>	Clock rise time	-	3	ns	C <sub>card</sub> ≤ 10 pF (1 card)
t <sub>THL</sub>	Clock fall time	-	3	ns	C <sub>card</sub> ≤ 10 pF (1 card)
<b>Inputs CMD, DAT (Referenced to CLK)</b>					
t <sub>ISU</sub>	Input setup time	6	-	ns	C <sub>card</sub> ≤ 10 pF (1 card)
t <sub>TH</sub>	Input hold time	2	-	ns	C <sub>card</sub> ≤ 10 pF (1 card)
<b>Outputs CMD, DAT (Referenced to CLK)</b>					
t <sub>ODLY</sub>	Output delay time during data transfer made	-	14	ns	CL ≤ 40 pF (1 card)
t <sub>OH</sub>	Output hold time	2.5	-	ns	CL ≥ 15 pF (1 card)
C <sub>L</sub>	Total system capacitance for each line*	-	40	pF	1 card

\*In order to satisfy severe timing, host shall run on only one card

### 4.3 MicroSD Interface Timing (SDR12, SDR25, SDR50 and SDR104 Modes) Input

#### 4.3.1 Clock Timing

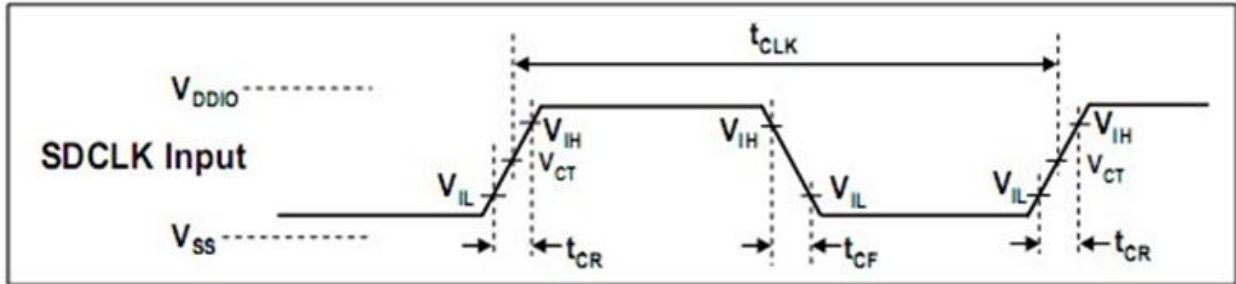

**Clock Signal Timing**

SYMBOL	MIN	MAX	UNIT	REMARK
t <sub>CLK</sub>	4.8	-	ns	208MHz (Max.), Between rising edge, V <sub>CT</sub> = 0.975V
t <sub>CR</sub> , t <sub>CF</sub>	-	0.2* t <sub>CLK</sub>	ns	t <sub>CR</sub> , t <sub>CF</sub> < 2.00ns (max.) at 208MHz, C <sub>CARD</sub> =10pF t <sub>CR</sub> , t <sub>CF</sub> < 2.00ns (max.) at 100MHz, C <sub>CARD</sub> =10pF The absolute maximum value of t <sub>CR</sub> , t <sub>CF</sub> is 10ns regardless of clock frequency.
Clock Duty	30	70	%	

#### 4.3.2 Card Input Timing

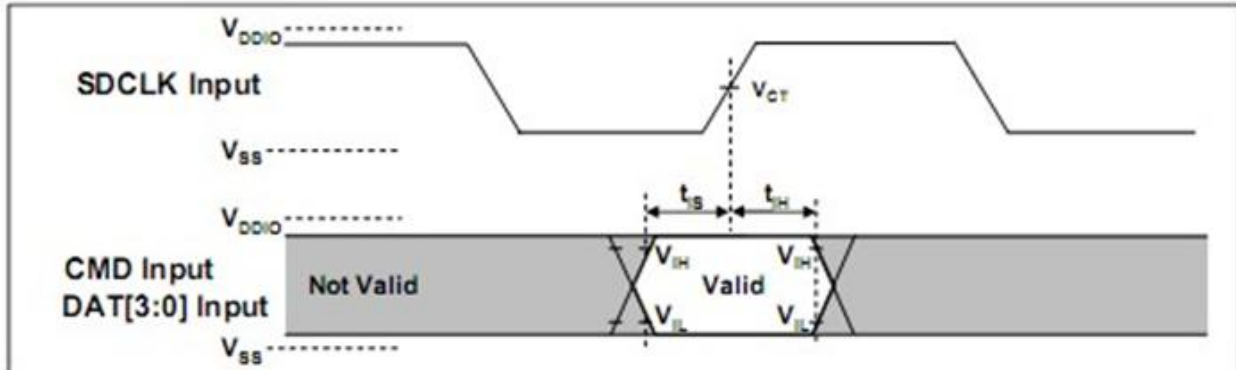

**Card Input Timing**

SYMBOL	MIN	MAX	UNIT	SDR104 MODE
t <sub>IS</sub>	1.40	-	ns	C <sub>CARD</sub> = 10pF, V <sub>CT</sub> = 0.975V
t <sub>IH</sub>	0.80	-	ns	C <sub>CARD</sub> = 5pF, V <sub>CT</sub> = 0.975V
SYMBOL	MIN	MAX	UNIT	SDR12, SDR25 and SDR50 MODES
t <sub>IS</sub>	3.00	-	ns	C <sub>CARD</sub> = 10pF, V <sub>CT</sub> = 0.975V
t <sub>IH</sub>	0.80	-	ns	C <sub>CARD</sub> = 5pF, V <sub>CT</sub> = 0.975V

### 4.3.3 Card Output Timing of Fixed Data Window (SDR12, SDR25 and SDR50)

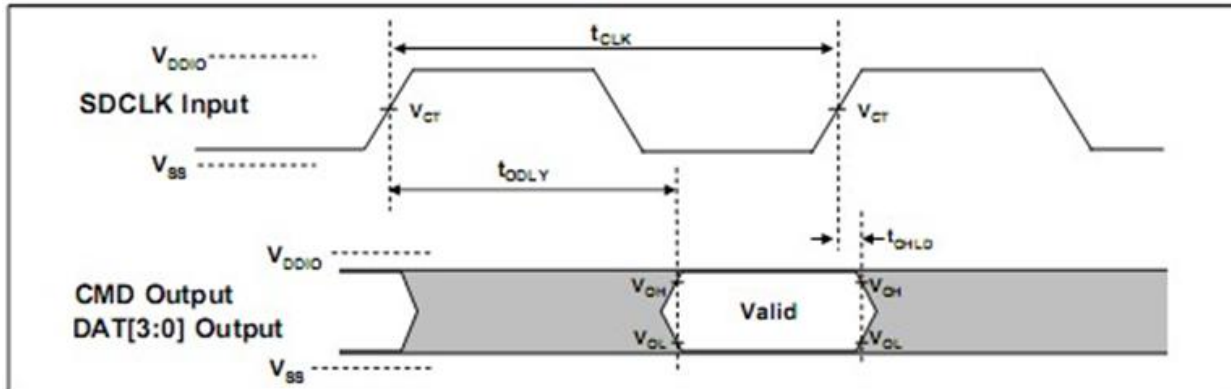

Output Timing of Fixed Date Window

SYMBOL	MIN	MAX	UNIT	REMARK
$t_{ODLY}$	-	7.5	ns	$t_{CLK} \geq 10.0ns$ , $CL=30pF$ , using driver Type B, for SDR50.
$t_{ODLY}$	-	14	ns	$t_{CLK} \geq 20.0ns$ , $CL=40pF$ , using driver Type B, for SDR25 and SDR12.
$t_{OH}$	1.5	-	ns	Hold time at the $t_{ODLY}$ (min.). $CL=15pF$

### 4.3.4 Output Timing of Variable Window (SDR104)

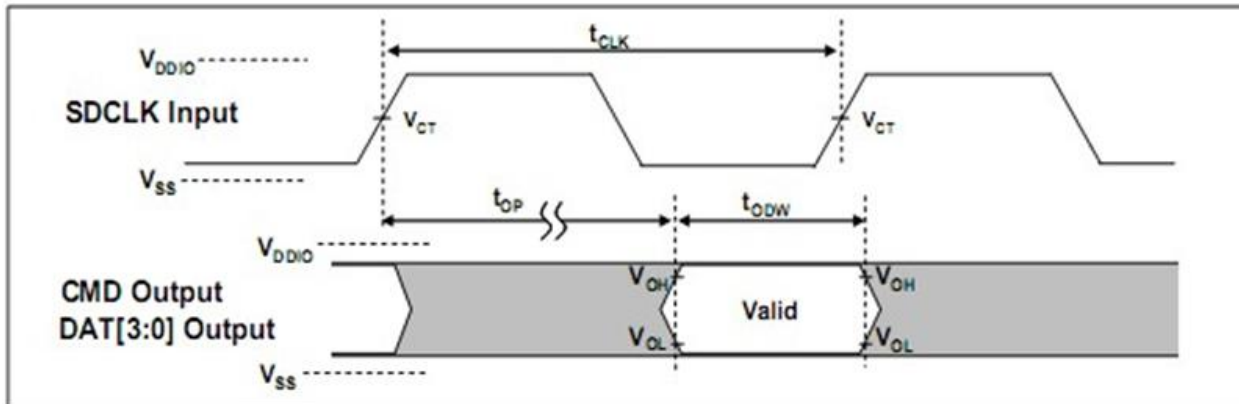

Output Timing of Variable Data Window

SYMBOL	MIN	MAX	UNIT	REMARK
$t_{OP}$	-	2	UI	Card Output Phase
$\Delta t_{OP}$	-350	+1550	ps	Delay variation due to temperature change after tuning
$t_{ODW}$	0.60	-	UI	$t_{ODW} = 2.88ns$ at 208MHz

4.3.5 SD Interface Timing (DDR50 Mode)

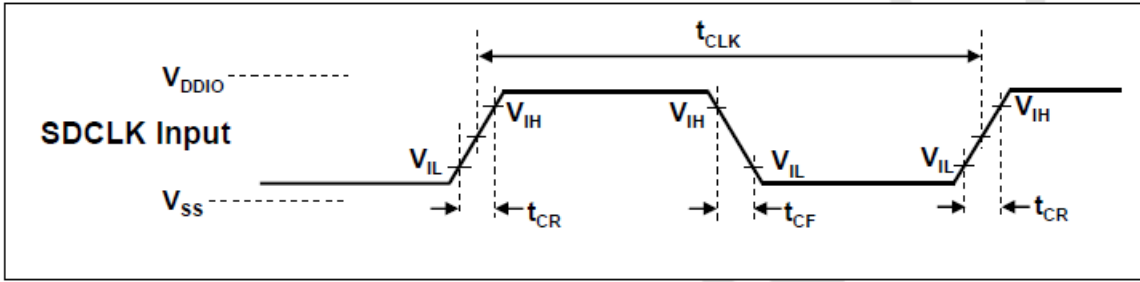

Clock Signal Timing

SYMBOL	MIN	MAX	UNIT	REMARK
$t_{CLK}$	20	-	ns	50MHz (Max.), Between rising edge
$t_{CR}, t_{CF}$	-	$0.2 * t_{CLK}$	ns	$t_{CR}, t_{CF} < 4.00ns$ (max.) at 50MHz, CCARD=10pF
Clock Duty	45	55	%	

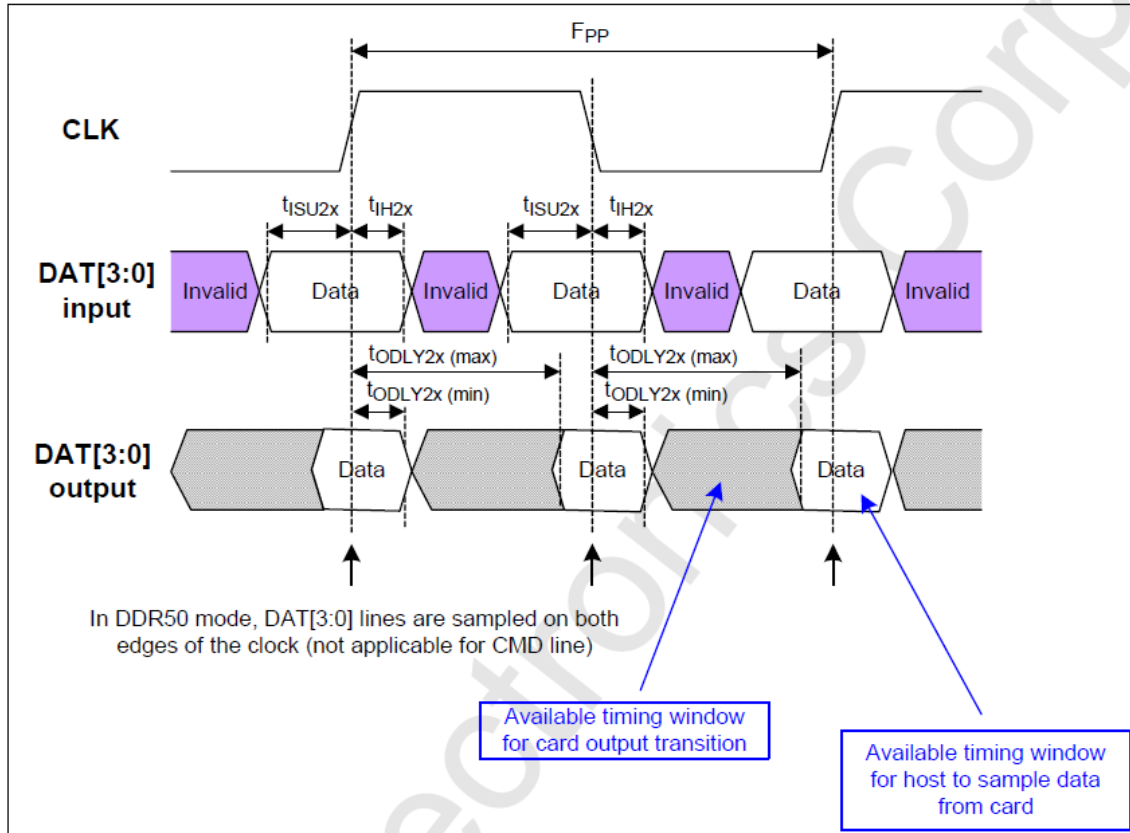

Timing Diagram DAT Inputs/Outputs Referenced to CLK in DDR50 Mode

### 4.3.6 Bus Timings – Parameters Values (DDR50 Mode)

Symbol	Parameters	Min	Max	Unit	Remark
<b>Input CMD</b> (referenced to CLK rising edge)					
t <sub>ISU</sub>	Input set-up time	6	-	ns	C <sub>card</sub> ≤ 10 pF (1 card)
t <sub>IH</sub>	Input hold time	0.8	-	ns	C <sub>card</sub> ≤ 10 pF (1 card)
<b>Output CMD</b> (referenced to CLK rising edge)					
t <sub>ODLY</sub>	Output Delay time during Data Transfer Mode	-	13.7	ns	C <sub>L</sub> ≤ 30 pF (1 card)
T <sub>OH</sub>	Output Hold time	1.5	-	ns	C <sub>L</sub> ≥ 15 pF (1 card)
<b>Inputs DAT</b> (referenced to CLK rising and falling edges)					
t <sub>ISU2x</sub>	Input set-up time	3	-	ns	C <sub>card</sub> ≤ 10 pF (1 card)
t <sub>IH2x</sub>	Input hold time	0.8	-	ns	C <sub>card</sub> ≤ 10 pF (1 card)
<b>Outputs DAT</b> (referenced to CLK rising and falling edges)					
t <sub>ODLY2x</sub>	Output Delay time during Data Transfer Mode	-	7.0	ns	C <sub>L</sub> ≤ 25 pF (1 card)
T <sub>OH2x</sub>	Output Hold time	1.5	-	ns	C <sub>L</sub> ≥ 15 pF (1 card)

## 5. Product Ordering Information

### 5.1 Product Code Designations

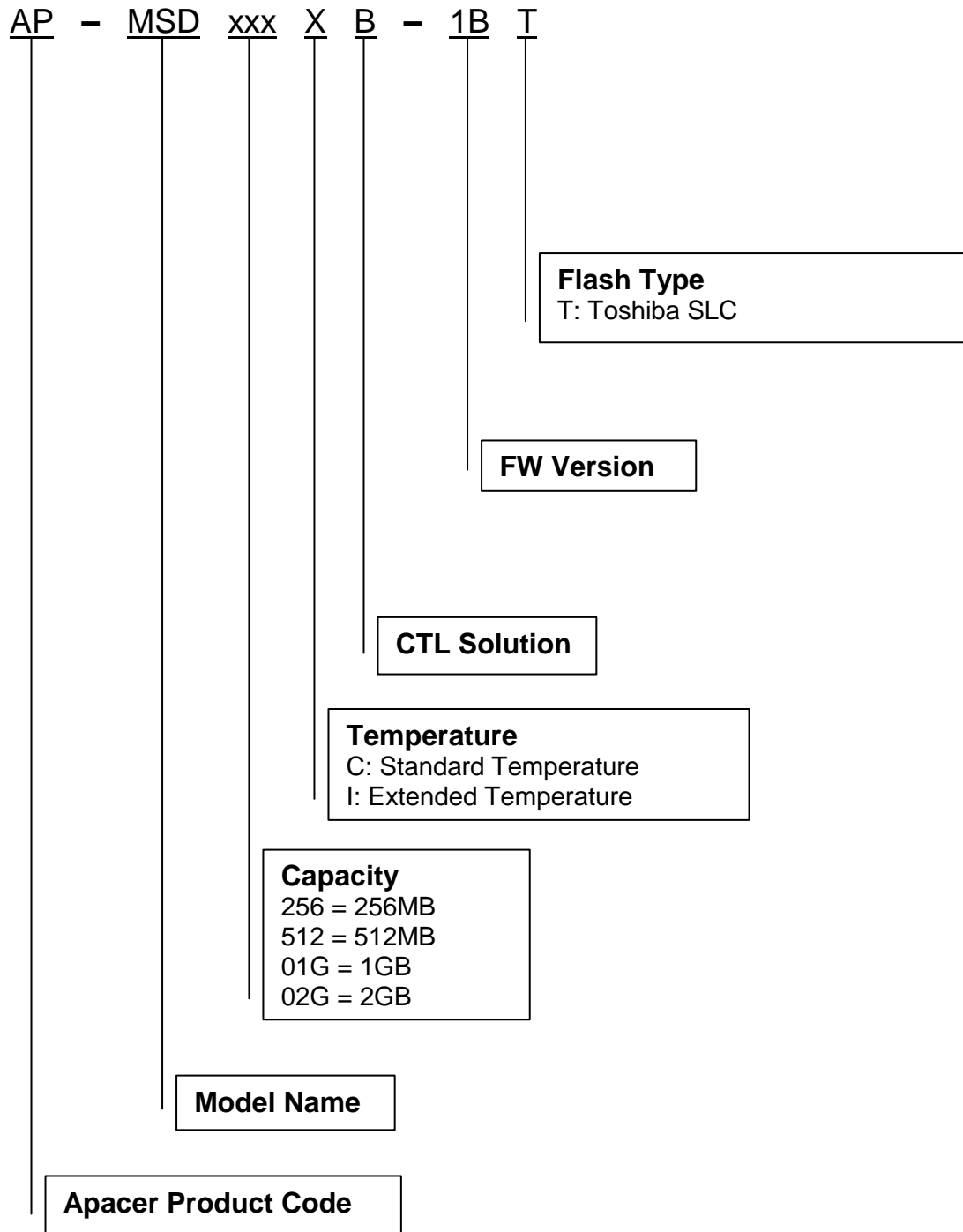

---

## 5.2 Valid Combinations

---

### 5.2.1 Standard Temperature

Capacity	AP/N
256MB	AP-MSD256CB-1BT
512MB	AP-MSD512CB-1BT
1GB	AP-MSD01GCB-1BT
2GB	AP-MSD02GCB-1BT

### 5.2.2 Extended Temperature

Capacity	AP/N
256MB	AP-MSD256IB-1BT
512MB	AP-MSD512IB-1BT
1GB	AP-MSD01GIB-1BT
2GB	AP-MSD02GIB-1BT

**Note:** Valid combinations are those products in mass production or will be in mass production. Consult your Apacer sales representative to confirm availability of valid combinations and to determine availability of new combinations.

---

## Revision History

Revision	Description	Date
1.0	Official release	1/26/2016
1.1	Added Power Failure Management to Features and General Description	10/3/2016

---

## Global Presence

<b>Taiwan (Headquarters)</b>	<b>Apacer Technology Inc.</b> 1F., No.32, Zhongcheng Rd., Tucheng Dist., New Taipei City 236, Taiwan R.O.C. Tel: 886-2-2267-8000 Fax: 886-2-2267-2261 <a href="mailto:amtsales@apacer.com">amtsales@apacer.com</a>
<b>U.S.A.</b>	<b>Apacer Memory America, Inc.</b> 46732 Lakeview Blvd., Fremont, CA 94538 Tel: 1-408-518-8699 Fax: 1-510-249-9551 <a href="mailto:sa@apacerus.com">sa@apacerus.com</a>
<b>Japan</b>	<b>Apacer Technology Corp.</b> 5F, Matsura Bldg., Shiba, Minato-Ku Tokyo, 105-0014, Japan Tel: 81-3-5419-2668 Fax: 81-3-5419-0018 <a href="mailto:jpservices@apacer.com">jpservices@apacer.com</a>
<b>Europe</b>	<b>Apacer Technology B.V.</b> Science Park Eindhoven 5051 5692 EB Son, The Netherlands Tel: 31-40-267-0000 Fax: 31-40-267-0000#6199 <a href="mailto:sales@apacer.nl">sales@apacer.nl</a>
<b>China</b>	<b>Apacer Electronic (Shanghai) Co., Ltd</b> Room D, 22/FL, No.2, Lane 600, JieyunPlaza, Tianshan RD, Shanghai, 200051, China Tel: 86-21-6228-9939 Fax: 86-21-6228-9936 <a href="mailto:sales@apacer.com.cn">sales@apacer.com.cn</a>
<b>India</b>	<b>Apacer Technologies Pvt Ltd,</b> Unit No.201, "Brigade Corner", 7 <sup>th</sup> Block Jayanagar, Yediyur Circle, Bangalore – 560082, India Tel: 91-80-4152-9061 Fax: 91-80-4170-0215 <a href="mailto:sales_india@apacer.com">sales_india@apacer.com</a>