

**RoHS Recast Compliant**

## **Industrial SDHC/XC 5.0**

**CH110-SD Product Specifications**

(Kioxia TLC BiCS3 64 Layers)

**April 19, 2022**

**Version 1.5**



**Apacer Technology Inc.**

1F, No.32, Zhongcheng Rd., Tucheng Dist., New Taipei City, Taiwan, R.O.C

Tel: +886-2-2267-8000 Fax: +886-2-2267-2261

[www.apacer.com](http://www.apacer.com)

## Specifications Overview:

- **Fully Compatible with SD Card Association Specifications**
  - Physical Layer Specification Ver6.1
  - Security Specification Ver4.0
- **Capacity**
  - 8, 16, 32, 64 GB
- **Performance<sup>1</sup>**
  - Sequential read: Up to 95 MB/sec
  - Sequential write: Up to 80 MB/sec
  - Random read (4K): Up to 1,700 IOPS
  - Random write (4K): Up to 600 IOPS
- **Flash Management**
  - Built-in advanced ECC algorithm
  - Global Wear Leveling
  - Flash bad-block management
  - Power Failure Management
  - Flash Translation Layer: Page Mapping
  - S.M.A.R.T.
  - SMART Read Refresh™
- **NAND Flash Type:** Kioxia TLC BiCS3 64 Layers
- **Firmware Version:** SLC-liteX
- **SD-Protocol Compatible**
- **Backward Compatible with 3.0 and 2.0**
- **Endurance (in Terabytes Written: TBW)**
  - 8 GB: 82 TBW
  - 16 GB: 191 TBW
  - 32 GB: 328 TBW
  - 64 GB: 543 TBW
- **Temperature Range**
  - Operating:
    - Standard: -25°C to 85°C
    - Wide: -40°C to 85°C
  - Storage: -40°C to 85°C
- **Operating Voltage: 2.7V ~ 3.6V**
- **Power Consumption<sup>1</sup>**
  - Operating: 80 mA
  - Standby: 135 µA
- **Bus Speed Mode:** Supports Class 10 with U3 and UHS-I<sup>2</sup>
  - SDR12: SDR up to 25MHz 1.8V signaling
  - SDR25: SDR up to 50MHz 1.8V signaling
  - SDR50: 1.8V signaling, frequency up to 100MHz, up to 50 MB/sec
  - SDR104: 1.8V signaling, frequency up to 208MHz, up to 104MB/sec
  - DDR50: 1.8V signaling, frequency up to 50MHz, sampled on both clock edges, up to 50 MB/sec
- **Supports SD SPI Mode**
- **Physical Dimensions**
  - 32mm (L) x 24mm (W) x 2.1mm (H)
- **Supported Speed Class:** C10, U3 and V30
- **RoHS Recast Compliant**

Notes:

1. Varies from capacities. Performance values presented here are typical and measured based on USB 3.0 card reader. The results may vary depending on settings and platforms.
2. Timing in 1.8V signaling is different from that of 3.3V signaling. Operation mode selection command is compliant with SD 3.0, referring to SDA's Part 1, Physical Layer Specification, Ver 3.01 (Section 3.9).

## Table of Contents

<b>1. General Description .....</b>	<b>4</b>
1.1 Functional Block.....	4
1.2 Flash Management .....	5
1.2.1 Bad Block Management.....	5
1.2.2 Powerful ECC Algorithms .....	5
1.2.3 S.M.A.R.T. ....	5
1.2.4 Global Wear Leveling .....	5
1.2.5 Power Failure Management.....	5
1.2.6 SMART Read Refresh™.....	5
1.2.7 Flash Translation Layer – Page Mapping.....	6
1.2.8 SLC-liteX.....	6
<b>2. Product Specifications.....</b>	<b>7</b>
2.1 Card Architecture .....	7
2.2 Pin Assignments .....	7
2.3 Capacity.....	8
2.4 Performance.....	8
2.5 Electrical.....	8
2.6 Endurance .....	9
<b>3. Physical Characteristics.....</b>	<b>10</b>
3.1 Physical Dimensions.....	10
3.2 Durability Specifications.....	11
<b>4. DC Characteristics .....</b>	<b>12</b>
4.1 SD Interface Timing (Default) .....	12
4.2 SD Interface Timing (High-Speed Mode).....	13
4.3 SD Interface Timing (SDR12, SDR25, SDR50 and SDR104 Modes).....	15
4.3.1 Input.....	15
4.3.2 Output .....	16
4.4 SD Interface Timing (DDR50 Mode) .....	17
<b>5. S.M.A.R.T. ....</b>	<b>19</b>
5.1 Direct Host Access to SMART Data via SD General Command (CMD56).....	19
5.2 Process for Retrieving SMART Data .....	19
<b>6. Product Ordering Information.....</b>	<b>22</b>

<b>6.1 Product Code Designations .....</b>	<b>22</b>
<b>6.2 Valid Combinations .....</b>	<b>23</b>

# 1. General Description

Apacer SD CH110-SD is compatible with the SD card version 5.0. The command list supports [Physical Layer Specification Ver6.10 Final] definitions. Card Capacity of Non-secure Area, Secure Area Supports [Part 3 Security Specification Ver4.00 Final] Specifications.

The SD 5.0 card comes with 9-pin interface designed to operate at a maximum operating frequency of 208MHz. It can alternate communication protocol between the SD mode and SPI mode. It performs data error detection and correction with very low power consumption. It supports capacity up to 64GB with exFAT SDXC.

Apacer SD CH110-SD Secure Digital 5.0 card with high performance, good reliability and wide compatibility is nowadays one of the most popular cards well adapted for hand-held applications with customized firmware techniques in semi-industrial/medical markets already.

## 1.1 Functional Block

The SD contains a flash controller and flash media with SD standard interface.

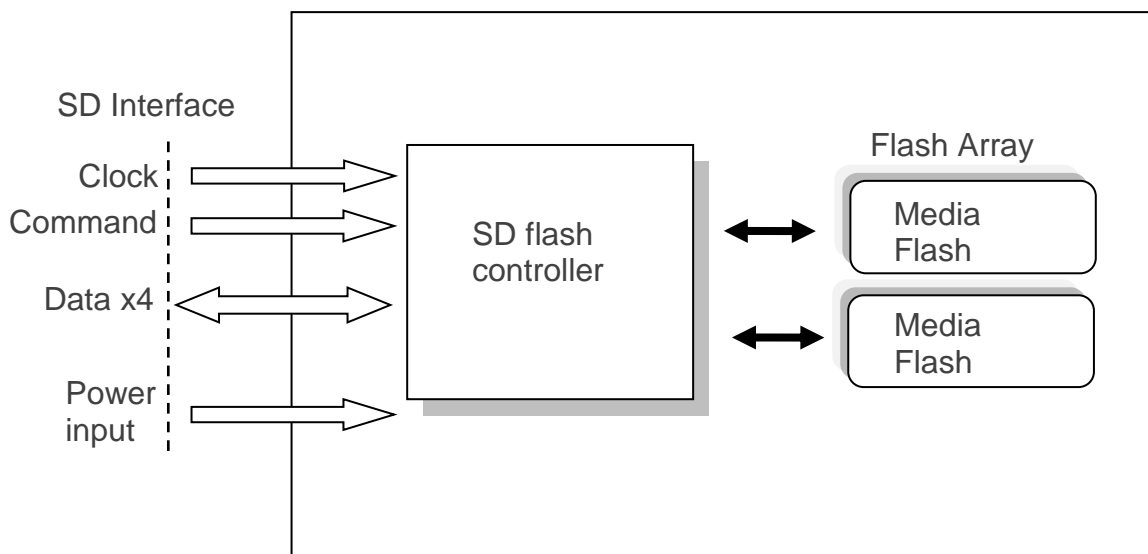

Figure 1-1 Functional Block Diagram

## 1.2 Flash Management

### 1.2.1 Bad Block Management

The SD controller contains logical/physical flash block mapping and bad block management system. It will manage all flash block include user data space and spare block.

The SD also contains a sophisticated defect and error management system. It does a read after write under margin conditions to verify that the data is written correctly (except in the case of write pre-erased sectors). In case that a bit is found to be defective, the SD replaces this bad bit with a spare bit within the sector header. If necessary, the SD will even replace the entire sector with a spare sector. This is completely transparent to the master (host device) and does not consume any user data space.

### 1.2.2 Powerful ECC Algorithms

Flash memory cells will deteriorate with use, which might generate random bit errors in the stored data. Thus, the SD card applies the advanced ECC Algorithm, which can detect and correct errors occur during read process, ensure data been read correctly, as well as protect data from corruption.

### 1.2.3 S.M.A.R.T.

SMART, an acronym for Self-Monitoring, Analysis and Reporting Technology, is a special function that allows a memory device to automatically monitor its health. Apacer provides a program named SmartInfo Tool to observe Apacer's SD and MicroSD cards. Note that this tool can only support Apacer's industrial SD and MicroSD cards. This tool will display firmware version, endurance life ratio, good block ratio, and so forth.

### 1.2.4 Global Wear Leveling

NAND Flash devices can only undergo a limited number of program/erase cycles, and in most cases, the flash media are not used evenly. If some area get updated more frequently than others, the lifetime of the device would be reduced significantly. Thus, Global Wear Leveling technique is applied to extend the lifespan of NAND Flash by evenly distributing writes and erase cycles across the media.

Apacer provides Global Wear Leveling algorithm, which can efficiently spread out the flash usage through the whole flash media area. Moreover, by implementing Global Wear Leveling algorithm, the life expectancy of the NAND Flash is greatly improved.

### 1.2.5 Power Failure Management

Power Failure Management plays a crucial role when power supply becomes unstable. Power disruption may occur when users are storing data into the SSD, leading to instability in the drive. However, with Power Failure Management, a firmware protection mechanism will be activated to scan pages and blocks once power is resumed. Valid data will be transferred to new blocks for merging and the mapping table will be rebuilt. Therefore, data reliability can be reinforced, preventing damage to data stored in the NAND Flash.

### 1.2.6 SMART Read Refresh™

Apacer's SMART Read Refresh plays a proactive role in avoiding read disturb errors from occurring to ensure health status of all blocks of NAND flash. Developed for read-intensive applications in particular, SMART Read Refresh is employed to make sure that during read operations, when the read operation threshold is reached, the data is refreshed by re-writing it to a different block for subsequent use.

## 1.2.7 Flash Translation Layer – Page Mapping

Page mapping is an advanced flash management technology whose essence lies in the ability to gather data, distribute the data into flash pages automatically, and then schedule the data to be evenly written. Page-level mapping uses one page as the unit of mapping. The most important characteristic is that each logical page can be mapped to any physical page on the flash memory device. This mapping algorithm allows different sizes of data to be written to a block as if the data is written to a data pool and it does not need to take extra operations to process a write command. Thus, page mapping is adopted to increase random access speed and improve SD lifespan, reduce block erase frequency, and achieve optimized performance and lifespan.

## 1.2.8 SLC-liteX

SLC-liteX is based on 3D NAND technology. The firmware is carefully tweaked by our engineering team so as to offer the greatest number of P/E cycles in this format – 30,000, which is 10 times more than MLC or industrial 3D TLC. The longest lifespans are therefore available at reasonable cost.



## 2.3 Capacity

The following table shows the specific capacity for the SD 5.0 card.

**Table 2-2 Capacity Specifications**

Capacity	Total bytes
8 GB	8,027,897,856
16 GB	16,064,184,320
32 GB	32,132,562,944
64 GB	64,223,182,848

Note: Total bytes are viewed under Windows operating system and were measured by SD format too.

## 2.4 Performance

Performances of the SD 5.0 card are shown in the table below.

**Table 2-3 Performance Specifications**

Capacity	8 GB	16 GB	32 GB	64 GB
<b>Sequential Read (MB/s)</b>	85	85	95	90
<b>Sequential Write (MB/s)</b>	65	75	80	80
<b>Random Read IOPS (4K)</b>	1,700	1,600	1,700	1,600
<b>Random Write IOPS (4K)</b>	500	600	400	600

Notes:

- Results may differ from various flash configurations or host system setting.
- Sequential read/write is based on CrystalDiskMark 5.2.1 with file size 1,000MB.
- Random read/write is measured using IOMeter with Queue Depth 32.
- Performance results are measured based on USB 3.0 card reader.

## 2.5 Electrical

**Table 2-4 Operating Voltages**

Symbol	Parameter	Min.	Max.	Unit
V <sub>DD</sub>	Power Supply Voltage	2.7	3.6	V

**Table 2-5 Power Consumption**

Mode	Capacity	8 GB	16 GB	32 GB	64 GB
<b>Operating (mA)</b>		70	70	75	80
<b>Standby (µA)</b>		85	90	130	135

Notes:

- All values are typical and may vary depending on flash configurations or host system settings.
- Active power is an average power measurement performed using CrystalDiskMark with 128KB sequential read/write transfers.
- Power is measured based on USB 3.0 card reader.

## 2.6 Endurance

The endurance of a storage device is predicted by TeraBytes Written based on several factors related to usage, such as the amount of data written into the drive, block management conditions, and daily workload for the drive. Thus, key factors, such as Write Amplifications and the number of P/E cycles, can influence the lifespan of the drive.

**Table 2-6 Endurance Specifications**

Capacity	TeraBytes Written
8 GB	82
16 GB	191
32 GB	328
64 GB	543

Notes:

- This estimation complies with Apacer internal workload.
- Flash vendor guaranteed 3D SLC-liteX P/E cycle: 30K
- WAF may vary from capacity, flash configurations and writing behavior on each platform.
- 1 Terabyte = 1,024GB



### 3.2 Durability Specifications

Table 3-1 Durability Specifications

Item	Specifications
Temperature	-25°C to 85°C (Standard) -40°C to 85°C (Wide)
	-40°C to 85°C (Storage)
Shock	1,500G, 0.5ms
Vibration	20Hz~80Hz/1.52mm (frequency/displacement) 80Hz~2000Hz/20G (frequency/displacement) X, Y, Z axis/60mins each
Drop	1.5m free fall, 6 surfaces of each
Bending	≥ 10N, hold 1min/5times
Torque	0.15N-m or 2.5deg, hold 30 seconds/ 5 times
Salt spray	Concentration: 3% NaCl at 35°C (storage for 24 hours)
Waterproof	JIS IPX7 compliance, Water temperature 25°C Water depth: the lowest point of unit is locating 1000mm below surface (storage for 30 mins)
X-Ray Exposure	0.1 Gy of medium-energy radiation (70 KeV to 140 KeV, cumulative dose per year) to both sides of the card ;storage for 30 mins)
Switch cycle	0.4~0.5N, 1000 times
Durability	10,000 times mating cycle
ESD	Contact: +/-4KV each item 25 times Air: +/-8KV 10 times

## 4. DC Characteristics

### 4.1 SD Interface Timing (Default)

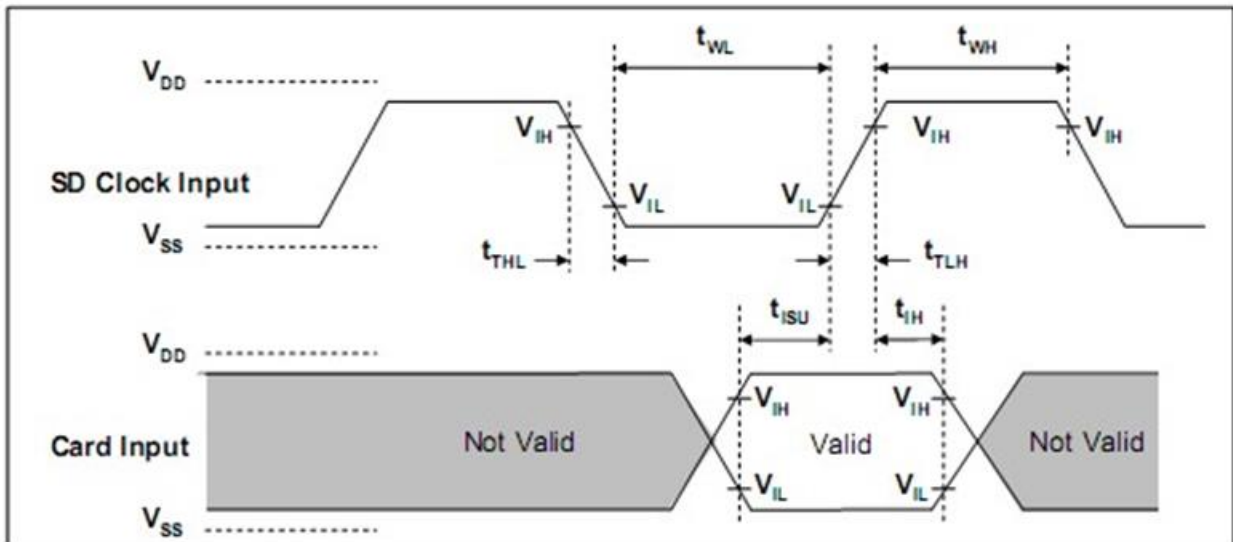

Card input Timing (Default Speed Card)

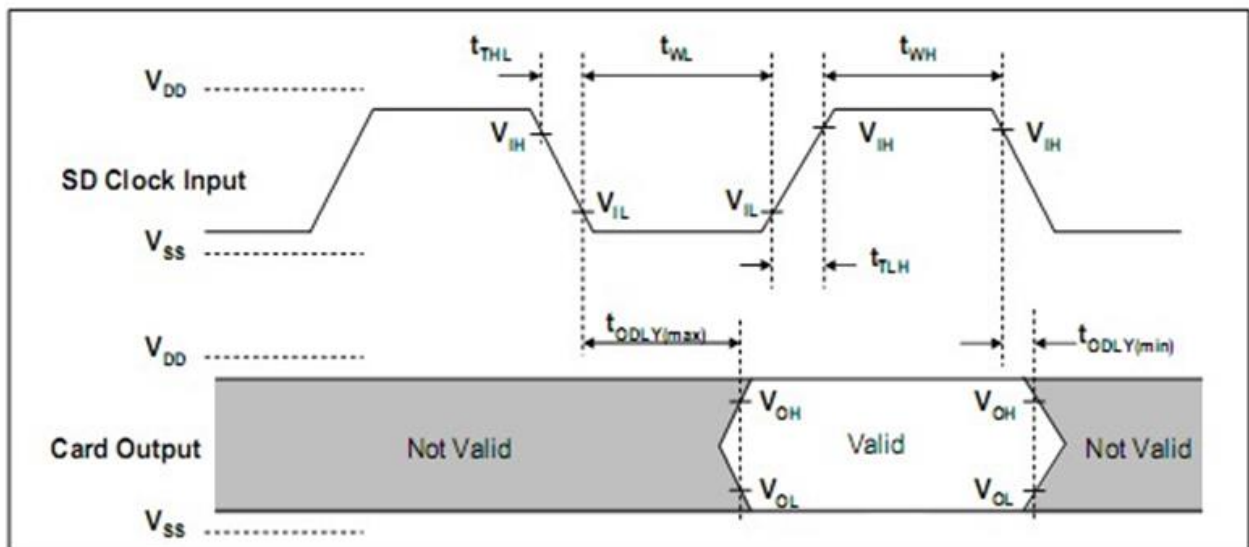

Card Output Timing (Default Speed Mode)

Symbol	Parameter	Min	Max	Unit	Remark
<b>Clock CLK (All values are referred to min(V<sub>IH</sub>) and max(V<sub>IL</sub>))</b>					
f <sub>PP</sub>	Clock frequency Data Transfer Mode	0	25	MHz	C <sub>card</sub> ≤ 10 pF (1 card)
f <sub>OD</sub>	Clock frequency Identification Mode	0*/100	400	kHz	C <sub>card</sub> ≤ 10 pF (1 card)
t <sub>WL</sub>	Clock low time	10		ns	C <sub>card</sub> ≤ 10 pF (1 card)
t <sub>WH</sub>	Clock high time	10		ns	C <sub>card</sub> ≤ 10 pF (1 card)
t <sub>TLH</sub>	Clock rise time		10	ns	C <sub>card</sub> ≤ 10 pF (1 card)
t <sub>THL</sub>	Clock fall time		10	ns	C <sub>card</sub> ≤ 10 pF (1 card)
<b>Inputs CMD, DAT (referenced to CLK)</b>					
t <sub>ISU</sub>	Input setup time	5		ns	C <sub>card</sub> ≤ 10 pF (1 card)
t <sub>IH</sub>	Input hold time	5		ns	C <sub>card</sub> ≤ 10 pF (1 card)
<b>Outputs CMD, DAT (referenced to CLK)</b>					
t <sub>ODLY</sub>	Output Delay time during Data Transfer Mode	0	14	ns	C <sub>L</sub> ≤ 40 pF (1 card)
t <sub>ODLY</sub>	Output Delay time during Identification Mode	0	50	ns	C <sub>L</sub> ≤ 40 pF (1 card)

\*0Hz means to stop the clock. The given minimum frequency range is for cases that require the clock to be continued.

## 4.2 SD Interface Timing (High-Speed Mode)

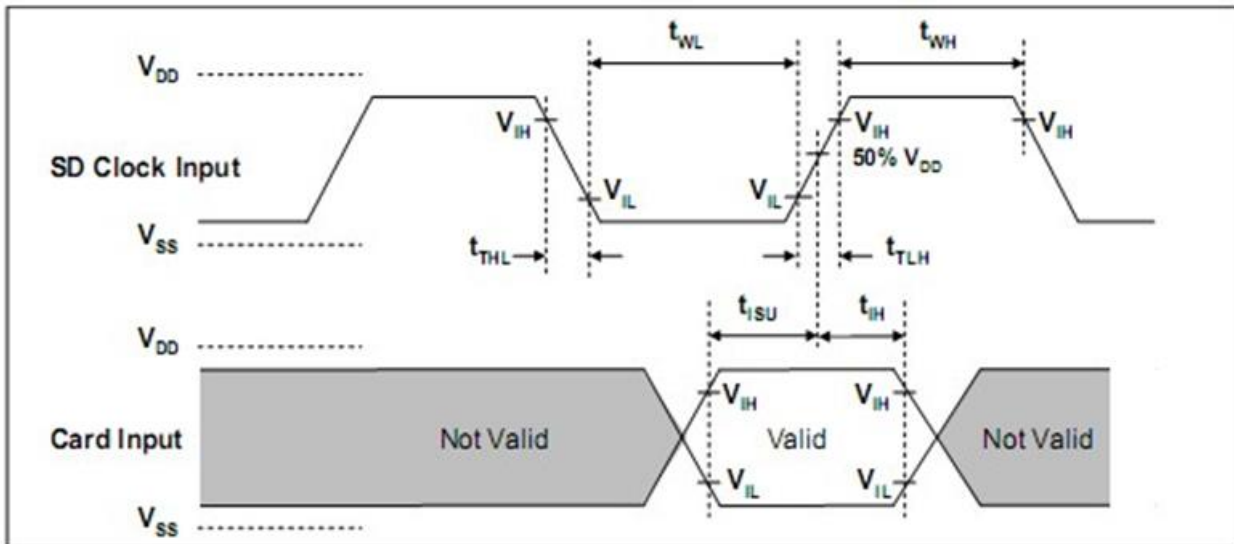

Card Input Timing (High Speed Card)

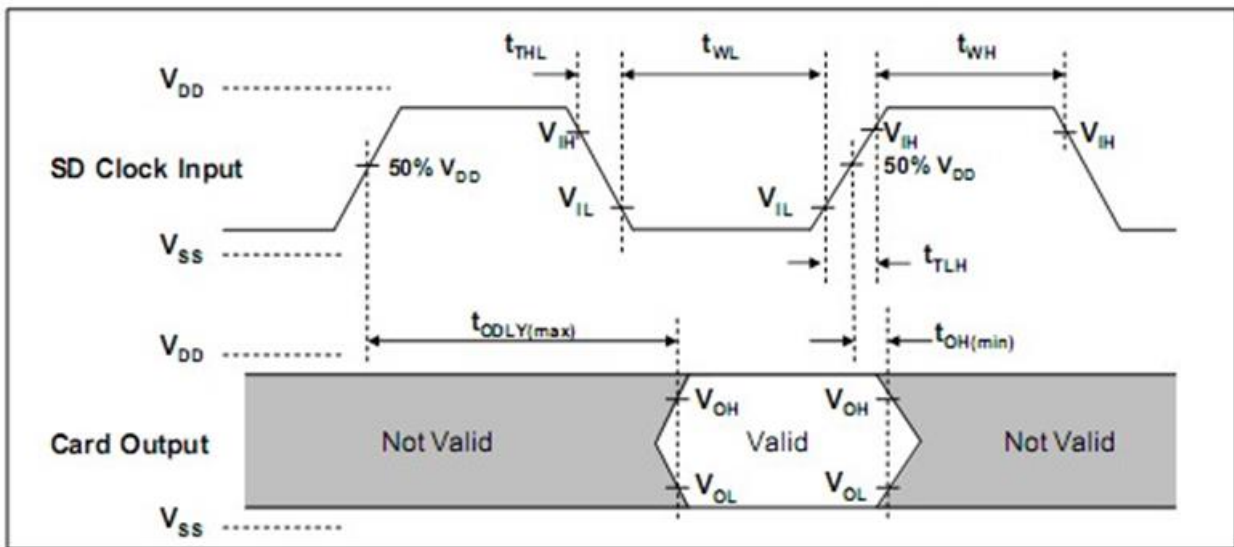

**Card Output Timing (High Speed Mode)**

Symbol	Parameter	Min	Max	Unit	Remark
<b>Clock CLK (All values are referred to min(<math>V_{IH}</math>) and max(<math>V_{IL}</math>))</b>					
$f_{PP}$	Clock frequency data transfer	0	50	MHz	$C_{card} \leq 10 \text{ pF}$ (1 card)
$t_{WL}$	Clock low time	7	-	ns	$C_{card} \leq 10 \text{ pF}$ (1 card)
$t_{WH}$	Clock high time	7	-	ns	$C_{card} \leq 10 \text{ pF}$ (1 card)
$t_{TLH}$	Clock rise time	-	3	ns	$C_{card} \leq 10 \text{ pF}$ (1 card)
$t_{THL}$	Clock fall time	-	3	ns	$C_{card} \leq 10 \text{ pF}$ (1 card)
<b>Inputs CMD, DAT (Referenced to CLK)</b>					
$t_{ISU}$	Input setup time	6	-	ns	$C_{card} \leq 10 \text{ pF}$ (1 card)
$t_{IH}$	Input hold time	2	-	ns	$C_{card} \leq 10 \text{ pF}$ (1 card)
<b>Outputs CMD, DAT (Referenced to CLK)</b>					
$t_{ODLY}$	Output delay time during data transfer made	-	14	ns	$CL \leq 40 \text{ pF}$ (1 card)
$t_{OH}$	Output hold time	2.5	-	ns	$CL \geq 15 \text{ pF}$ (1 card)
$CL$	Total system capacitance for each line*	-	40	pF	1 card

\*In order to satisfy severe timing, host shall run on only one card

### 4.3 SD Interface Timing (SDR12, SDR25, SDR50 and SDR104 Modes)

#### 4.3.1 Input

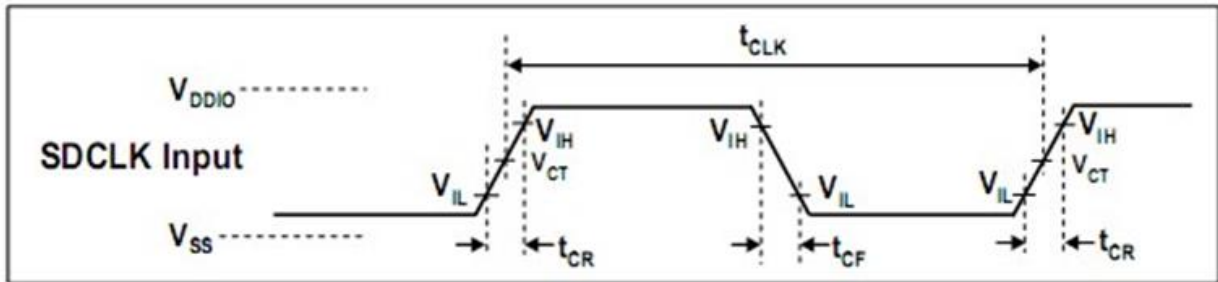

Clock Signal Timing

Symbol	Min	Max	Unit	Remark
$t_{CLK}$	4.8	-	ns	208MHz (Max.), Between rising edge, $V_{CT} = 0.975V$
$t_{CR}, t_{CF}$	-	$0.2 * t_{CLK}$	ns	$t_{CR}, t_{CF} < 2.00ns$ (max.) at 208MHz, $C_{CARD}=10pF$ $t_{CR}, t_{CF} < 2.00ns$ (max.) at 100MHz, $C_{CARD}=10pF$ The absolute maximum value of $t_{CR}, t_{CF}$ is 10ns regardless of clock frequency.
Clock Duty	30	70	%	

#### SDR12, SDR25, SDR50 and SDR104 Input Timing

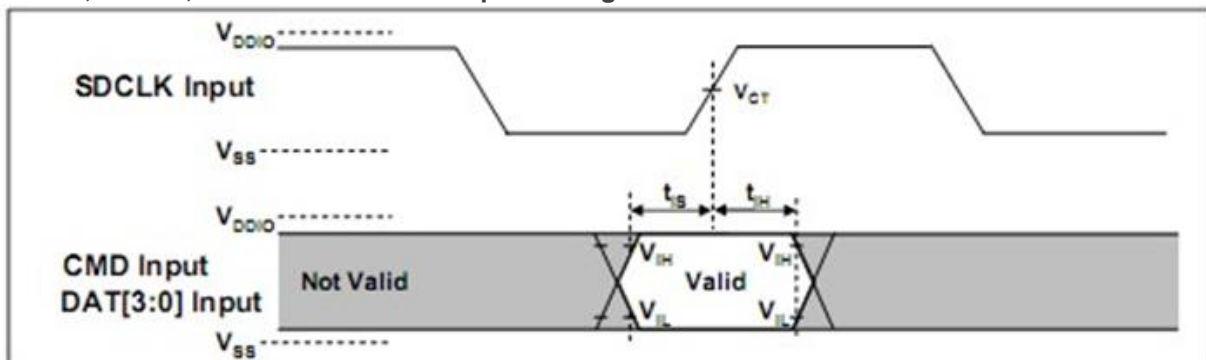

Card Input Timing

Symbol	Min	Max	Unit	SDR104 Mode
$t_S$	1.40	-	ns	$C_{CARD} = 10pF, V_{CT} = 0.975V$
$t_H$	0.80	-	ns	$C_{CARD} = 5pF, V_{CT} = 0.975V$
Symbol	Min	Max	Unit	SDR12, SDR25 and SDR50 Modes
$t_S$	3.00	-	ns	$C_{CARD} = 10pF, V_{CT} = 0.975V$
$t_H$	0.80	-	ns	$C_{CARD} = 5pF, V_{CT} = 0.975V$

### 4.3.2 Output

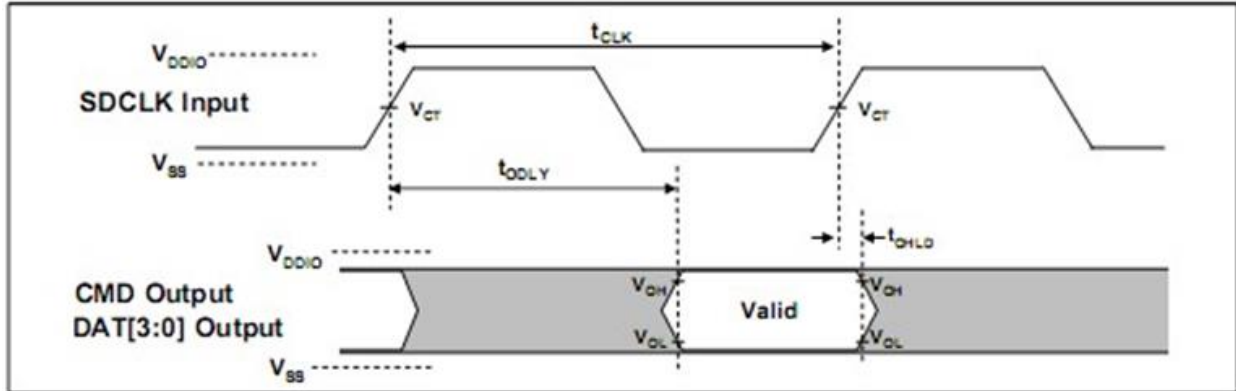

Output Timing of Fixed Data Window

Symbol	Min	Max	Unit	Remark
$t_{ODLY}$	-	7.5	ns	$t_{CLK} \geq 10.0\text{ns}$ , $C_L=30\text{pF}$ , using driver Type B, for SDR50.
$t_{ODLY}$	-	14	ns	$t_{CLK} \geq 20.0\text{ns}$ , $C_L=40\text{pF}$ , using driver Type B, for SDR25 and SDR12
$T_{OH}$	1.5	-	ns	Hold time at the $t_{ODLY}$ (min.). $C_L=15\text{pF}$

#### Output (SDR104 mode)

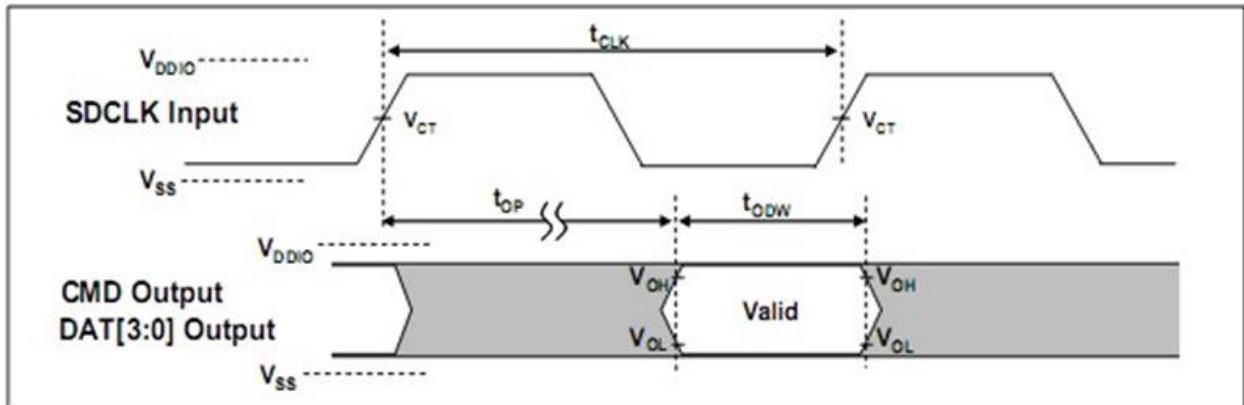

Symbol	Min	Max	Unit	Remark
$t_{OP}$	0	2	UI	Card Output Phase
$\Delta t_{OP}$	-350	+1550	ps	Delay variable due to temperature change after tuning
$t_{ODW}$	0.60	-	UI	$t_{ODW} = 2.88\text{ns}$ at 208MHz

### 4.4 SD Interface Timing (DDR50 Mode)

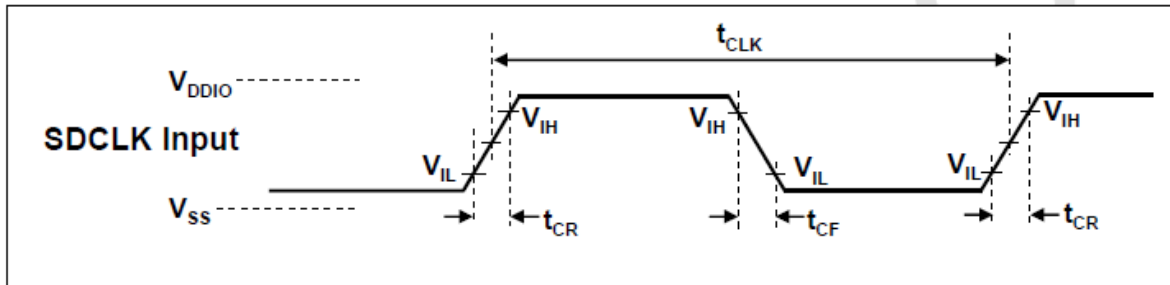

Clock Signal Timing

Symbol	Min	Max	Unit	Remark
$t_{CLK}$	20	-	ns	50MHz (Max.), Between rising edge
$t_{CR}, t_{CF}$	-	0.2 $t_{CLK}$	ns	$t_{CR}, t_{CF} < 4.00ns$ (max.) at 50MHz, $C_{CARD}=10pF$
Clock Duty	45	55	%	

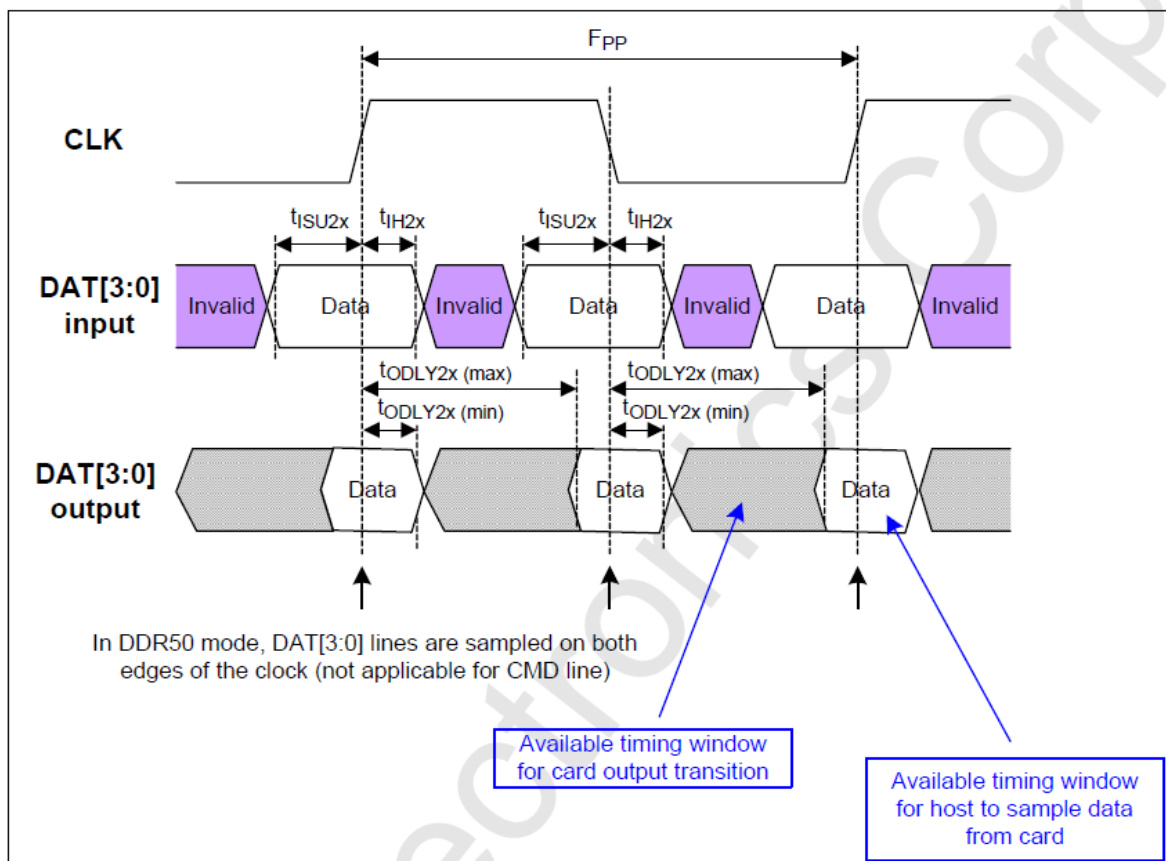

Timing Diagram DAT Inputs/Outputs Referenced to CLK in DDR50 Mode

**Bus Timings – Parameters Values (DDR50 Mode)**

Symbol	Parameter	Min	Max	Unit	Remark
<b>Input CMD (referenced to CLK rising edge)</b>					
t <sub>ISU</sub>	Input setup time	6	-	ns	C <sub>card</sub> ≤ 10 pF (1 card)
t <sub>IH</sub>	Input hold time	0.8	-	ns	C <sub>card</sub> ≤ 10 pF (1 card)
<b>Output CMD (referenced to CLK rising edge)</b>					
t <sub>ODLY</sub>	Output Delay time during Data Transfer Mode	-	13.7	ns	C <sub>L</sub> ≤ 30 pF (1 card)
T <sub>OH</sub>	Output Hold time	1.5	-	ns	C <sub>L</sub> ≥ 15 pF (1 card)
<b>Inputs DAT (referenced to CLK rising and falling edges)</b>					
t <sub>ISU2x</sub>	Input setup time	3	-	ns	C <sub>card</sub> ≤ 10 pF (1 card)
t <sub>IH2x</sub>	Input hold time	0.8	-	ns	C <sub>card</sub> ≤ 10 pF (1 card)
<b>Outputs DAT (referenced to CLK rising and falling edges)</b>					
t <sub>ODLY2x</sub>	Output Delay time during Data Transfer Mode	-	7.0	ns	C <sub>L</sub> ≤ 25 pF (1 card)
T <sub>OH2x</sub>	Output Hold time	1.5	-	ns	C <sub>L</sub> ≥ 15 pF (1 card)

## 5. S.M.A.R.T.

### 5.1 Direct Host Access to SMART Data via SD General Command (CMD56)

CMD 56 is structured as a 32-bit argument. The implementation of the general purpose functions will arrange the CMD56 argument into the following format:

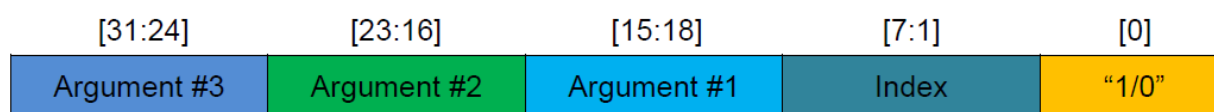

- Bit [0]: Indicates Read Mode when bit is set to [1] or Write Mode when bit is cleared [0]. Depending on the function, either Read Mode or Write Mode can be used.
- Bit [7:1]: Indicates the index of the function to be executed:
  - Read Mode: Index = 0x10 Get SMART Command Information
  - Write Mode: Index = 0x08 Pre-Load SMART Command Information
- Bit [15:8]: Function argument #1 (1-byte)
- Bit [23:16]: Function argument #2 (1-byte)
- Bit [31:24]: Function argument #3 (1-byte)

### 5.2 Process for Retrieving SMART Data

Retrieving SMART data requires the following two commands executed in sequence and in accordance with the SD Association standard flowchart for CMD56 (see below).

#### Step 1: Write Mode – [0x08] Pre-Load SMART Command Information

Sequence	Command	Argument	Expected Data
Pre-Load SMART Command Information	CMD56	[0] "0" (Write Mode) [1:7] "0001 000" (Index = 0x08) [8:511] All '0' (Reserved)	No expected data

## Step 2: Read Mode – [0x10] Get SMART Command Information

Sequence	Command	Argument	Expected Data
Get SMART Command Information	CMD56	[0] "1" (Read Mode) [1:7] "0010 000" (Index = 0x10) [8:31] All '0' (Reserved)	1 sector (512 bytes) of response data  byte[0-8] Flash ID byte[9-10] IC Version byte[11-12] FW Version byte[13] Reserved byte[14] CE Number byte[15] Reserved byte[16-17] Bad Block Replace Maximum byte[18] Reserved byte[32-63] Bad Block count per Die byte[64-65] Good Block Rate(%) byte[66-79] Reserved byte[80-83] Total Erase Count byte[84-95] Reserved byte[96-97] Endurance (Remain Life) (%) byte[98-99] Average Erase Count – L* byte[100-101] Minimum Erase Count – L* byte[102-103] Maximum Erase Count – L* byte[104-105] Average Erase Count – H* byte[106-107] Minimum Erase Count – H* byte[108-109] Maximum Erase Count – H* byte[110-111] Reserved byte[112-115] Power Up Count byte[116-127] Reserved byte[128-129] Abnormal Power Off Count byte[130-159] Reserved byte[160-161] Total Refresh Count byte[176-183] Product "Marker" byte[184-215] Bad Block count per Die byte[216-511] Reserved

\*Please refer to technical note for High/Low byte definition.

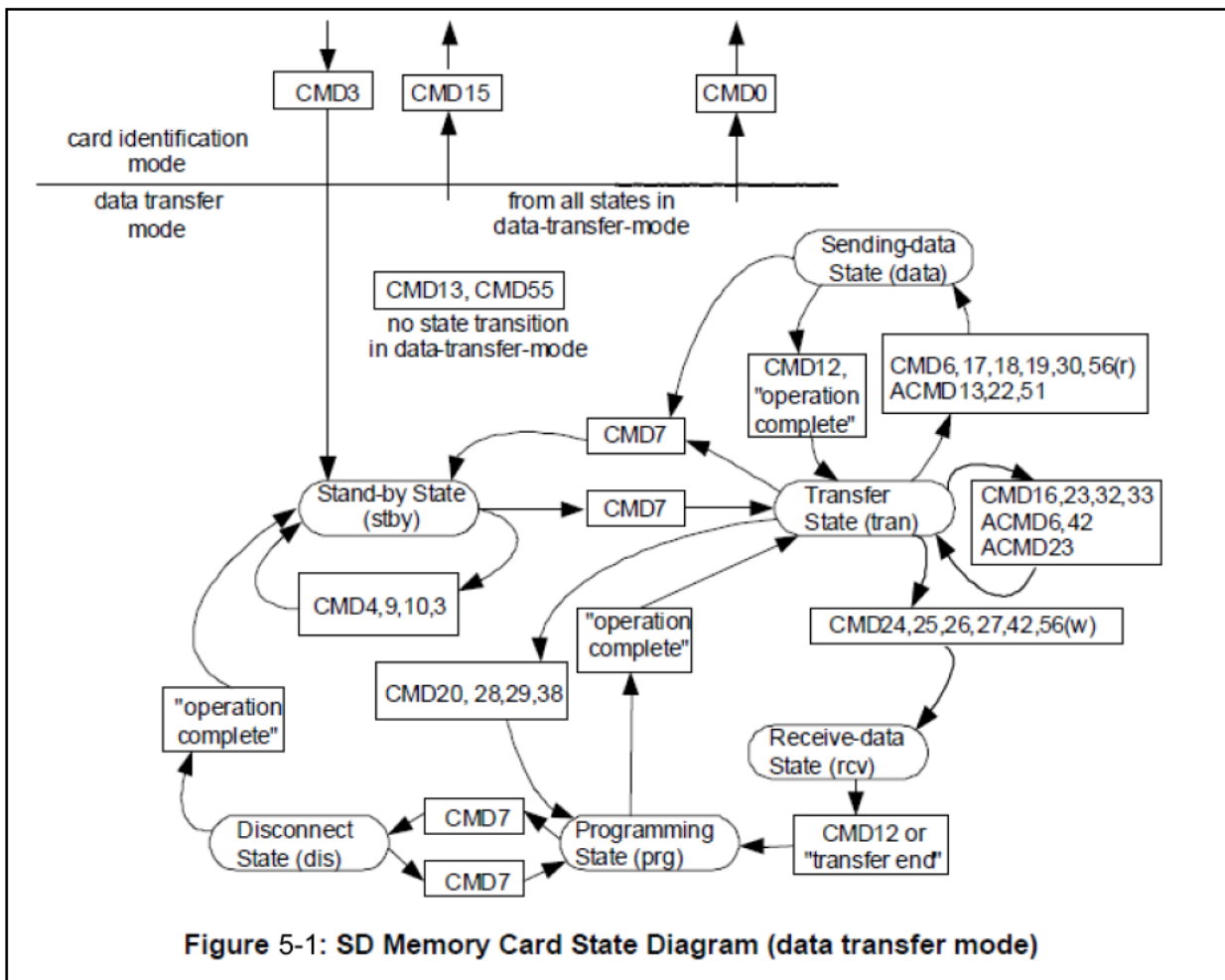

Figure 5-1: SD Memory Card State Diagram (data transfer mode)

Extracted from the SD Specifications Part 1 Physical Layer Simplified Specification Version 3.01.

## 6. Product Ordering Information

### 6.1 Product Code Designations

Apacer's CH110-SD is available in different configurations and densities. See the chart below for a comprehensive list of options for the CH110-SD series devices.

Code	1	2	3	4	5	6	7	8	9	10	11	12	13	14	15	16
	A	J	6	.	1	1	8	X	X	A	.	X	X	X	0	7

<b>Code 1-3 (Product Line &amp; Form Factor)</b>	CH110-SD
<b>Code 5-6 (Model/Solution)</b>	CH110
<b>Code 7-8 (Product Capacity)</b>	8F: 8GB 8G: 16GB 8H: 32GB 8J: 64GB
<b>Code 9 (Flash Type &amp; Product Temp)</b>	S: 3D SLC lite-X standard temperature T: 3D SLC lite-X wide temperature
<b>Code 10 (Product Spec)</b>	SD Card
<b>Code 12-14 (Version Number)</b>	Random number generated by system
<b>Code 15-16 (Firmware Version)</b>	Firmware page mode

## 6.2 Valid Combinations

The following table lists the available models of the CH110-SD series which are in mass production or will be in mass production. Consult your Apacer sales representative to confirm availability of valid combinations and to determine availability of new combinations.

Capacity	Standard Temperature	Wide Temperature
8GB	AJ6.118FSA.00107	AJ6.118FTA.00107
16GB	AJ6.118GSA.00107	AJ6.118GTA.00107
32GB	AJ6.118HSA.00107	AJ6.118HTA.00107
64GB	AJ6.118JSA.00107	AJ6.118JTA.00107

## Revision History

Revision	Description	Date
1.0	Initial release	2/24/2020
1.1	Updated supported bus mode from UHS-I to Class 10 with U3 and UHS-I at Bus Speed Mode on Specifications Overview	3/31/2020
1.2	Modified code 9 and the description of code 9-10 at 6.1 Product Code Designations	10/22/2020
1.3	Updated endurance rating for 8GB at 2.6 Endurance	11/17/2020
1.4	- Removed DataRAID support - Updated NAND flash type on the cover page and Specifications Overview page from Toshiba to Kioxia	6/9/2021
1.5	Modified SD card version from 6.1 to 5.0	4/19/2022

## Global Presence

### Taiwan (Headquarters)

#### Apacer Technology Inc.

1F., No.32, Zhongcheng Rd., Tucheng Dist.,  
New Taipei City 236, Taiwan R.O.C.

Tel: 886-2-2267-8000

Fax: 886-2-2267-2261

[amtsales@apacer.com](mailto:amtsales@apacer.com)

### U.S.A.

#### Apacer Memory America, Inc.

46732 Lakeview Blvd., Fremont, CA 94538

Tel: 1-408-518-8699

Fax: 1-510-249-9551

[sa@apacerus.com](mailto:sa@apacerus.com)

### Japan

#### Apacer Technology Corp.

6F, Daiyontamachi Bldg., 2-17-12, Shibaura, Minato-Ku,  
Tokyo, 108-0023, Japan

Tel: 81-3-5419-2668

Fax: 81-3-5419-0018

[jpservices@apacer.com](mailto:jpservices@apacer.com)

### Europe

#### Apacer Technology B.V.

Science Park Eindhoven 5051 5692 EB Son,  
The Netherlands

Tel: 31-40-267-0000

Fax: 31-40-290-0686

[sales@apacer.nl](mailto:sales@apacer.nl)

### China

#### Apacer Electronic (Shanghai) Co., Ltd

Room D, 22/FL, No.2, Lane 600, JieyunPlaza,  
Tianshan RD, Shanghai, 200051, China

Tel: 86-21-6228-9939

Fax: 86-21-6228-9936

[sales@apacer.com.cn](mailto:sales@apacer.com.cn)

### India

#### Apacer Technologies Pvt Ltd,

1874, South End C Cross, 9<sup>th</sup> Block Jayanagar,  
Bangalore-560069, India

Tel: 91-80-4152-9061/62

Fax: 91-80-4170-0215

[sales\\_india@apacer.com](mailto:sales_india@apacer.com)