

*Halogen-free*

## **CompactFlash Series 6**

*Specifications for Industrial CompactFlash Card*

**November 8<sup>th</sup>, 2012**

*Version 1.0*

**Apacer**  
*Access the best*

**Apacer Technology Inc.**

4<sup>th</sup> Fl., 75 Hsin Tai Wu Rd., Sec.1, Xizhi, Taipei Hsien 221, Taiwan

Tel: +886-2-2698-2888 Fax: +886-2-2698-2889

[www.apacer.com](http://www.apacer.com)

## Features:

- **CompactFlash Association Specification Revision 6.0 Standard Interface**
  - ATA command set compatible
  - ATA transfer mode supports:
    - PIO Mode 6
    - Multiword DMA Mode 4
    - Ultra DMA Mode 6
    - PCMCIA UDMA Mode 5
- **Capacities**
  - 16, 32, 64 GB
- **Performance\***
  - Sustained read: Up to 115 MB/sec
  - Sustained write: Up to 80 MB/sec
- **Intelligent ATA/IDE module**
  - Wear-leveling algorithms to substantially increase longevity of flash media
  - Built-in BCH ECC capable of correcting up to 72 bits in 1KB data
  - Supports S.M.A.R.T commands
- **NAND Flash Type: SLC**
- **Power Management**
- **Power Smart Design**
  - Built-in 1.2V Power-On-Reset
  - Built-in 2.7V Voltage detector for power fail protection
- **Temperature ranges**
  - 0°C to 70°C for operation (Standard)
  - -40°C to 85°C (extended temperature)
  - -40°C to 100°C for storage
- **Operating voltage for read and write**
  - 3.3 V
  - 5.0 V
- **Power consumption (typical)\***
  - Active mode: 255 mA
  - Standby mode: 2 mA
- **Connector Type**
  - 50 pins female
- **Physical Dimensions**
  - 36.4mm x 42.8mm x 3.3mm
- **Halogen free**

\*Performance and power consumption may vary depending on capacities, flash configuration or host system settings.

---

## Table of Contents

<b>1. GENERAL DESCRIPTION</b>	<b>3</b>
1.1 PERFORMANCE-OPTIMIZED CONTROLLER	3
1.1.1 Power Management	3
1.1.2 RAM	3
1.1.3 Error Correction Code (ECC)	3
1.2 INTELLIGENT ENDURANCE DESIGN	3
1.2.1 Wear-leveling algorithms	3
1.2.2 S.M.A.R.T. Technology	4
1.2.3 Flash Block Management	4
1.2.4 Power Failure Management	4
<b>2. FUNCTIONAL BLOCK</b>	<b>5</b>
<b>3. PIN ASSIGNMENTS</b>	<b>6</b>
<b>4. PRODUCT SPECIFICATION</b>	<b>8</b>
4.1 CAPACITY	8
4.2 PERFORMANCE	8
4.3 ENVIRONMENTAL SPECIFICATIONS	8
4.4 CERTIFICATION & COMPLIANCE	9
<b>5. SOFTWARE INTERFACE</b>	<b>10</b>
5.1 CF-ATA COMMAND SET	10
<b>6. OPERATING CONDITIONS</b>	<b>12</b>
<b>7. PHYSICAL CHARACTERISTICS</b>	<b>13</b>
7.1 DIMENSION	13
<b>8. PRODUCT ORDERING INFORMATION</b>	<b>14</b>
8.1 PRODUCT CODE DESIGNATIONS	14

---

## 1. General Description

Apacer's value-added Industrial CompactFlash Card offers high performance, high reliability and power-efficient storage. Regarding standard compliance, this CompactFlash Card complies with CompactFlash specification revision 6.0, supporting transfer modes up to Programmed Input Output (PIO) Mode 6, Multi-word Direct Memory Access (DMA) Mode 4, Ultra DMA Mode 6, and PCMCIA Ultra DMA Mode 5.

For power efficiency, this industrial CompactFlash card supports some power smart design mechanisms such as Power-On-Reset, voltage regulator for output voltage adjustments and power failure protection, as well as the automatic sleep and wake-up feature.

Apacer's value-added CFC provides complete PCMCIA – ATA functionality and compatibility. Apacer's CompactFlash technology is designed for applications in Point of Sale (POS) terminals, telecom, IP-STB, medical instruments, surveillance systems, industrial PCs and handheld applications such as the new generation of Digital Single Lens Reflex (DSLR) cameras.

### 1.1 Performance-Optimized Controller

---

The CompactFlash Card Controller translates standard CF signals into flash media data and control signals.

#### 1.1.1 Power Management

The controller unit of this CompactFlash is built with power management design that optimizes power utilization and voltage flow. It enhances the power efficiency of CompactFlash Card Controller by employing advanced circuit regulator technology.

#### 1.1.2 RAM

The controller is implemented with RAM as a data process to optimize data transfer between the host and the flash media.

#### 1.1.3 Error Correction Code (ECC)

The CompactFlash card is programmed with BCH Error Detection Code (EDC) and Error Correction Code (ECC) algorithms capable of correcting up to 72 random bits in 1KB bytes data.

High performance is achieved through hardware-based error detection and correction.

## 1.2 Intelligent Endurance Design

---

### 1.2.1 Wear-leveling algorithms

Flash memory devices differ from Hard Disk Drives (HDDs) in terms of how blocks are utilized. For HDDs, when a change is made to stored data, like erase or update, the controller mechanism on HDDs will perform overwrites on blocks. Unlike HDDs, flash blocks cannot be overwritten and each P/E cycle wears down the lifespan of blocks gradually. Repeatedly program/erase cycles performed on the same memory cells will eventually cause some blocks to age faster than others. This would bring flash storages to their end of service term sooner. Wear leveling is an important mechanism that level out the wearing of blocks so that the wearing-down of blocks can be almost evenly distributed. This will increase the lifespan of SSDs. Commonly used wear leveling types are Static and Dynamic.

---

### **1.2.2 S.M.A.R.T. Technology**

S.M.A.R.T. is an acronym for Self-Monitoring, Analysis and Reporting Technology, an open standard allowing disk drives to automatically monitor their own health and report potential problems. It protects the user from unscheduled downtime by monitoring and storing critical drive performance and calibration parameters. Ideally, this should allow taking proactive actions to prevent impending drive failure. Apacer SMART feature adopts the standard SMART command B0h to read data from the drive. When the Apacer SMART Utility running on the host, it analyzes and reports the disk status to the host before the device is in critical condition.

### **1.2.3 Flash Block Management**

Current production technology is unable to guarantee total reliability of NAND flash memory array. When a flash memory device leaves factory, it comes with a minimal number of initial bad blocks during production or out-of-factory as there is no currently known technology that produce flash chips free of bad blocks. In addition, bad blocks may develop during program/erase cycles. When host performs program/erase command on a block, bad block may appear in Status Register. Since bad blocks are inevitable, the solution is to keep them in control. Apacer flash devices are programmed with ECC, block mapping technique and S.M.A.R.T to reduce invalidity or error. Once bad blocks are detected, data in those blocks will be transferred to free blocks and error will be corrected by designated algorithms.

### **1.2.4 Power Failure Management**

Power Failure Management ensures data transmission when experiencing unstable power supply. When power disruption takes places, NAND Flash will have to cache multiple write-to-flash cycles to ensure that no data is lost. This urgent operation requires about several milliseconds to get it done. When the supplied voltage is below a certain percentage of the required, the flash controller will be signaled by a detector IC component with low power detection signal and then the firmware will communicate the controller to flush all the data into the cache of Flash storage area. This can prevent incomplete data transmission.

## 2. Functional Block

The CompactFlash Card (CFC) includes a controller and flash media, as well as the CompactFlash standard interface. Figure 2-1 shows the functional block diagram.

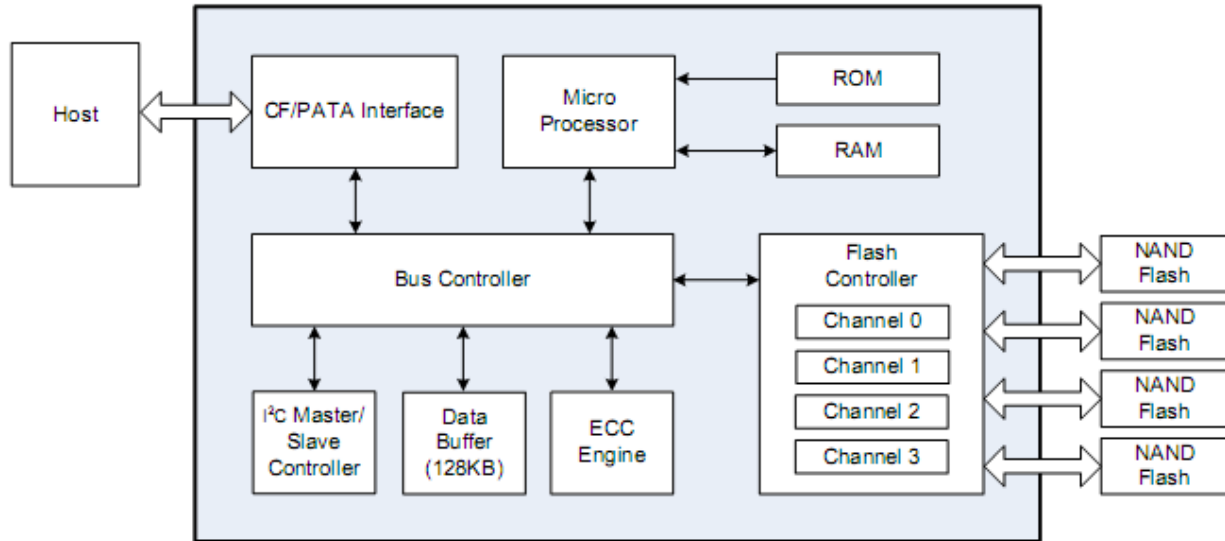

Figure 2-1: Functional block diagram

For Internal Use

### 3. Pin Assignments

Table 3-1 lists the pin assignments with respective signal names for the 50-pin configuration. A “#” suffix indicates the active low signal. The pin type can be input, output or input/output.

**Table 3-1:** Pin assignments (1 of 2)

Pin No.	Memory card mode		I/O card mode		True IDE mode	
	Signal name	Pin I/O type	Signal name	Pin I/O type	Signal name	Pin I/O type
1	GND	-	GND	-	GND	-
2	D3	I/O	D3	I/O	D3	I/O
3	D4	I/O	D4	I/O	D4	I/O
4	D5	I/O	D5	I/O	D5	I/O
5	D6	I/O	D6	I/O	D6	I/O
6	D7	I/O	D7	I/O	D7	I/O
7	#CE1	I	#CE1	I	#CS0	I
8	A10	I	A10	I	A10 <sup>1</sup>	I
9	#OE	I	#OE	I	#ATA SEL	I
10	A9	I	A9	I	A9 <sup>1</sup>	I
11	A8	I	A8	I	A8 <sup>1</sup>	I
12	A7	I	A7	I	A7 <sup>1</sup>	I
13	VCC	-	VCC	-	VCC	-
14	A6	I	A6	I	A6 <sup>1</sup>	I
15	A5	I	A5	I	A5 <sup>1</sup>	I
16	A4	I	A4	I	A4 <sup>1</sup>	I
17	A3	I	A3	I	A3 <sup>1</sup>	I
18	A2	I	A2	I	A2	I
19	A1	I	A1	I	A1	I
20	A0	I	A0	I	A0	I
21	D0	I/O	D0	I/O	D0	I/O
22	D1	I/O	D1	I/O	D1	I/O
23	D2	I/O	D2	I/O	D2	I/O
24	WP	O	#IOIS16	O	#IOCS16	O
25	#CD2	O	#CD2	O	#CD2	O
26	#CD1	O	#CD1	O	#CD1	O
27	D11	I/O	D11	I/O	D11	I/O
28	D12	I/O	D12	I/O	D12	I/O
29	D13	I/O	D13	I/O	D13	I/O
30	D14	I/O	D14	I/O	D14	I/O
31	D15	I/O	D15	I/O	D15	I/O
32	#CE2	I	#CE2	I	#CS1	I
33	#VS1	O	#VS1	O	#VS1	O
34	#IORD	I	#IORD	I	#IORD	I
35	#IOWR	I	#IOWR	I	#IOWR	I
36	#WE	I	#WE	I	#WE	I
37	RDY/-BSY	O	#IREQ	O	INTRQ	O
38	VCC	-	VCC	-	VCC	-
39	#CSEL	I	#CSEL	I	#CSEL	I
40	#VS2	O	#VS2	O	#VS2	O
41	RESET	I	RESET	I	#RESET	I

**Table 3-1:** Pin assignments (2 of 2)

Pin No.	Memory card mode		I/O card mode		True IDE mode	
	Signal name	Pin I/O type	Signal name	Pin I/O type	Signal name	Pin I/O type
42	#WAIT	O	#WAIT	O	IORDY	O
43	#INPACK	O	#INPACK	O	DMARQ <sup>2</sup>	O
44	#REG	I	#REG	I	DMACK <sup>2</sup>	I
45	BVD2	O	#SPKR	O	#DASP	I/O
46	BVD1	O	#STSCHG	O	#PDIAG	I/O
47	D8	I/O	D8	I/O	D8	I/O
48	D9	I/O	D9	I/O	D9	I/O
49	D10	I/O	D10	I/O	D10	I/O
50	GND	-	GND	-	GND	-

1. The signal should be grounded by the host.
2. Connection required when UDMA is in use.

For Internal Evaluation

## 4. Product Specification

### 4.1 Capacity

Capacity specification of the Compact Flash Card series (CFC) is available as shown in Table 4-1. It lists the specific capacity and the default numbers of heads, sectors and cylinders for each product line.

**Table 4-1:** Capacity specifications

Capacity	Total bytes <sup>1</sup>	Cylinders	Heads	Sectors	Max LBA
16GB	16,391,340,032	16,383	16	63	32,014,336
32GB	32,019,316,736	16,383	16	63	62,537,728
64 GB	64,030,244,864	16,383	16	63	125,059,072

Notes:

Display of total bytes varies from operating systems.

Cylinders, heads or sectors are not applicable for these capacities. Only LBA addressing applies

Notes: 1 GB = 1,000,000,000 bytes; 1 sector = 512 bytes.

LBA count addressed in the table above indicates total user storage capacity and will remain the same throughout the lifespan of the device. However, the total usable capacity of the SSD is most likely to be less than the total physical capacity because a small portion of the capacity is reserved for device maintenance usages.

### 4.2 Performance

Performances of the CF cards are listed in Table 4-2

**Table 4-2:** Performance specifications

Capacity	16 GB	32 GB	64 GB
<b>Performance</b>			
<b>Sustained read (MB/s)</b>	110	110	115
<b>Sustained write (MB/s)</b>	55	75	80

Notes: performance may vary depending on flash configurations or host system settings.

### 4.3 Environmental Specifications

Environmental specification of the Compact Flash Card series (CFC) which follows the MIL-STD-810F standards is available as shown in Table 4-3.

**Table 4-3:** Environmental specifications

Environment	Specification
Temperature	Operation 0°C to 70°C; -40°C to 85°C (Extended Temperature)
	Storage -40°C to 100°C
Humidity	5% to 95% RH (Non-condensing)
Vibration (Non-Operating)	Sine wave : 10~2000Hz, 15G (X, Y, Z axes)
Shock (Non-Operating)	Half sine wave 1,500G (X, Y, Z ; All 6 axes)

---

## 4.4 Certification & Compliance

---

The CompactFlash card complies with the following global standards:

- CE
- FCC
- Halogen-free
- EMC

For Internal Evaluation

## 5. Software Interface

### 5.1 CF-ATA Command Set

Table 5-1 summarizes the CF-ATA command set with the paragraphs that follow describing the individual commands and the task file for each.

**Table 5-1:** CFC-ATA command set

Command Set	Command	Code	Protocol
CFA Feature Set	Request Sense	03h	Non-data
	Write Sectors Without Erase	38h	PIO data-out
	Erase Sectors	C0h	Non-data
	Write Multiple Without Erase	CDh	PIO data-out
	Translate Sector	87h	PIO data-in
	Set Features Enable/Disable 8-bit Transfer	EFh	Non-data
General Feature Set	Execute Drive Diagnostic	90h	Device diagnostic
	Flush Cache	E7h	Non-data
	Identify Device	ECh	PIO data-in
	Read DMA	C8h	DMA
	Read Multiple	C4h	PIO data-in
	Read Sector(s)	20h or 21h	PIO data-in
	Read Verify Sector(s)	40h or 41h	Non-data
	Set Feature	EFh	Non-data
	Set Multiple Mode	C6h	Non-data
	Write DMA	CAh	DMA
	Write Multiple	C5h	PIO data-out
	Write Sector(s)	30h or 31h	PIO data-out
	NOP	00h	Non-data
	Read Buffer	E4h	PIO data-in
	Write Buffer	E8h	PIO data-out
	Set Feature	EFh	Non-data
Power Management Feature Set	Check Power Mode	E5h or 98h	Non-data
	Idle	E3h or 97h	Non-data
	Idle Immediate	E1h or 95h	Non-data
	Sleep	E6h or 99h	Non-data
	Standby	E2h or 96h	Non-data
	Standby Immediate	E0h or 94h	Non-data

# Compact Flash 6 series

## AP-CFxxxxRAXS-XXXXXX



Security Mode Feature Set	Security Set Password	F1h	PIO data-out
	Security Unlock	F2h	PIO data-out
	Security Erase Prepare	F3h	Non-data
	Security Erase Unit	F4h	PIO data-out
	Security Freeze Lock	F5h	Non-data
	Security Disable Password	F6h	PIO data-out
SMART Feature Set	SMART Disable Operations	B0h	Non-data
	SMART Enable/Disable Autosave	B0h	Non-data
	SMART Enable Operations	B0h	Non-data
	SMART Return Status	B0h	Non-data
	SMART Execute Off-line Immediate	B0h	Non-data
	SMART Read Data	B0h	PIO data-in
Host Protected Area Feature Set	Read Native Max Address	F8h	Non-data
	Set Max Address	F9h	Non-data
	Set Max Set Password	F9h	PIO data-out
	Set Max Lock	F9h	Non-data
	Set Max Freeze Lock	F9h	Non-data
	Set Max Unlock	F9h	PIO data-out
Others	Format Track	50h	PIO data-out
	Initialize Drive Parameters	91h	Non-data
	Recalibrate	1Xh	Non-data
	Seek	7Xh	Non-data
	Wear Level	F5h	Non-data
	Write Verify	3Ch	PIO data-out
48-bit Address Feature Set	Read Sector Ext	24h	PIO data-in
	Read DMA Ext	25h	DMA
	Read Multiple Ext	29h	PIO data-in
	Write Sector Ext	34h	PIO data-out
	Write DMA Ext	35h	DMA
	Read Verify Sector Ext	42h	Non-data
	Write Multiple FUA Ext	CEh	PIO data-out
	Flush Cache Ext	EAh	Non-data

## 6. Operating Conditions

Table 6-1: Operating range

Parameters	Range
Ambient temperature	0°C to 70°C
Extended temperature	-40°C to 85°C
Supply voltage at 3.3V	3.135 ~ 3.465 V
Supply voltage at 5V	4.75 ~ 5.25 V

Table 6-2: Power consumption (typical)

Mode \ Capacity	16 GB	32 GB	64 GB
Active (mA)	240	245	255
Stand By (mA)	2	2	2

Note: Power consumptions may vary depending on settings and platforms

# 7. Physical Characteristics

## 7.1 Dimension

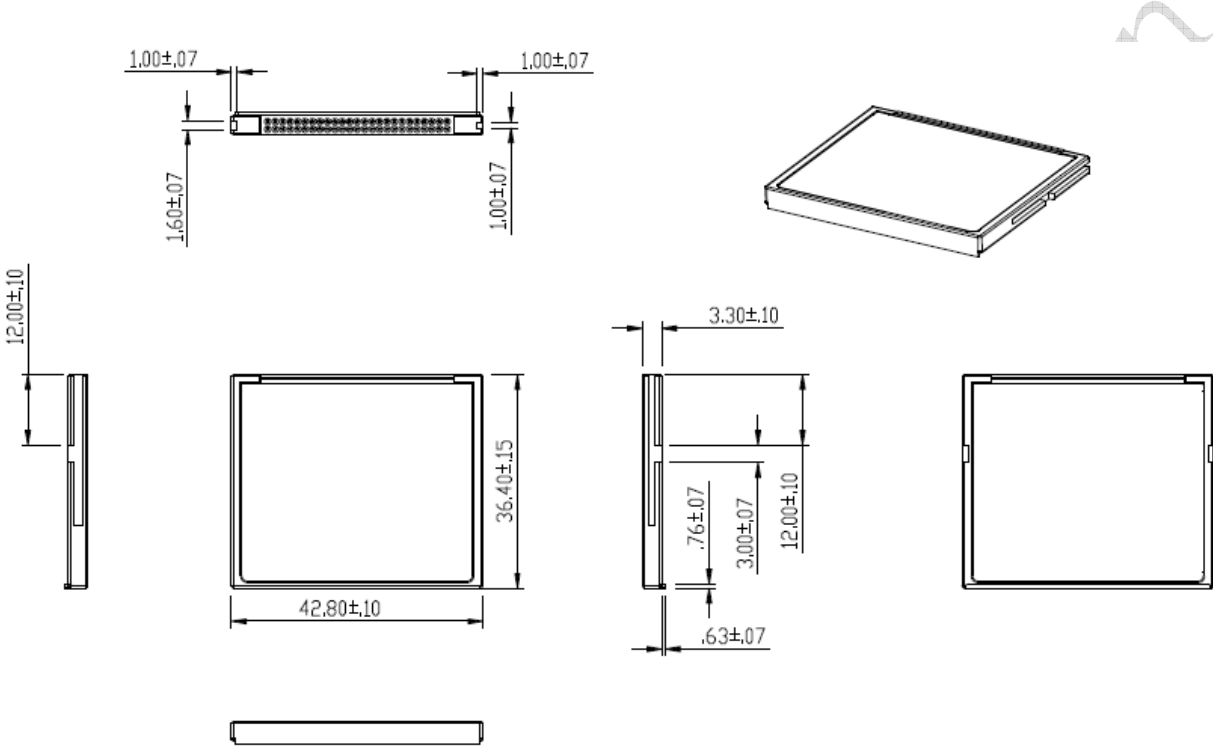

FIGURE 7-1: Physical dimension

Unit: mm

## 8. Product Ordering Information

### 8.1 Product Code Designations

**A P - C F x x x x R A X S - X X X X X X**

**Specification**

RM: Removable  
 NR: Non-Removable  
 ET: Extended Temperature  
 NDRM: Non-DMA + Removable  
 NDNR: Non-DMA + Non-Removable  
 ETRM: Ext. Temp. + Removable  
 ETNR: Ext. Temp. + Non-Removable  
 ETNDRM: Ext. Temp + Non-DMA + Removable  
 ETNDNR: Ext. Temp + Non-DMA + Non-Removable

**Halogen Free Compliant**

**Configuration**

E : Single Channel  
 F : Dual Channel

**CTL Type**

**CFC Type**

**Capacities:**

016G	16GB
032G	32GB
064G	64GB

**Model Name**

**Apacer Product Code**

---

## 8.2 Valid Combinations

---

### 8.2.1 Standard Temperature

#### 8.2.1.1 Non-Removable

<i>Capacity</i>	<i>AP/N</i>
16GB	AP-CF016GRAFS-NR
32GB	AP-CF032GRAFS-NR
64GB	AP-CF064GRAFS-NR

#### 8.2.1.2 Removable

<i>Capacity</i>	<i>AP/N</i>
16GB	AP-CF016GRAFS-RM
32GB	AP-CF032GRAFS-RM
64GB	AP-CF064GRAFS-RM

#### 8.2.1.3 Non-DMA + Removable

<i>Capacity</i>	<i>AP/N</i>
16GB	AP-CF016GRAFS-NDRM
32GB	AP-CF032GRAFS-NDRM
64GB	AP-CF064GRAFS-NDRM

#### 8.2.1.4 Non-DMA + Non-Removable

<i>Capacity</i>	<i>AP/N</i>
16GB	AP-CF016GRAFS-NDNR
32GB	AP-CF032GRAFS-NDNR
64GB	AP-CF064GRAFS-NDNR

---

## 8.2.2 Extended Temperature

### 8.2.2.1 Ext. Temp. + Non-Removable

<b>Capacity</b>	<b>AP/N</b>
16GB	AP-CF016GRAFS-ETNR
32GB	AP-CF032GRAFS-ETNR
64GB	AP-CF064GRAFS-ETNR

### 8.2.2.2 Ext. Temp. + Removable

<b>Capacity</b>	<b>AP/N</b>
16GB	AP-CF016GRAFS-ETRM
32GB	AP-CF032GRAFS-ETRM
64GB	AP-CF064GRAFS-ETRM

### 8.2.2.3 Non-DMA + Removable

<b>Capacity</b>	<b>AP/N</b>
16GB	AP-CF016GRAFS-ETNDRM
32GB	AP-CF032GRAFS-ETNDRM
64GB	AP-CF064GRAFS-ETNDRM

### 8.2.2.4 Non-DMA + Non-Removable

<b>Capacity</b>	<b>AP/N</b>
16GB	AP-CF016GRAFS-ETNDNR
32GB	AP-CF032GRAFS-ETNDNR
64GB	AP-CF064GRAFS-ETNDNR

**Note:** Please consult with Apacer sales representatives for availabilities.

---

## Revision History

Revision	Date	Description	Remark
1.0	11/08/2012	Official release	

For Internal Evaluation

---

## Global Presence

<b>Taiwan (Headquarters)</b>	<b>Apacer Technology Inc.</b> 4 <sup>th</sup> Fl., 75 Hsin Tai Wu Rd., Sec.1 Xizhi, 221 Taipei Hsien Taiwan, R.O.C. Tel: +886-2-2698-2888 Fax: +886-2-2698-2889 <a href="mailto:amtsales@apacer.com">amtsales@apacer.com</a>
<b>U.S.A.</b>	<b>Apacer Memory America, Inc.</b> 386 Fairview Way, Suite102, Milpitas, CA 95035 Tel: 1-408-518-8699 Fax: 1-408-935-9611 <a href="mailto:sa@apacerus.com">sa@apacerus.com</a>
<b>Japan</b>	<b>Apacer Technology Corp.</b> 5F, Matsura Bldg., Shiba, Minato-Ku Tokyo, 105-0014, Japan Tel: 81-3-5419-2668 Fax: 81-3-5419-0018 <a href="mailto:jpservices@apacer.com">jpservices@apacer.com</a>
<b>Europe</b>	<b>Apacer Technology B.V.</b> Science Park Eindhoven 5051 5692 EB Son, The Netherlands Tel: 31-40-267-0000 Fax: 31-40-267-0000#6199 <a href="mailto:sales@apacer.nl">sales@apacer.nl</a>
<b>China</b>	<b>Apacer Electronic (Shanghai) Co., Ltd</b> 1301, No.251, Xiaomuqiao Road, Shanghai, 200032, China Tel: 86-21-5529-0222 Fax: 86-21-5206-6939 <a href="mailto:sales@apacer.com.cn">sales@apacer.com.cn</a>
<b>India</b>	<b>Apacer Technologies Pvt. Ltd.</b> # 535, 1st Floor, 8th cross, JP Nagar 3rd Phase, Bangalore – 560078, India Tel: 91-80-4152-9061 <a href="mailto:sales_india@apacer.com">sales_india@apacer.com</a>