

Halogen-free & RoHS Recast Compliant **CH710-CF** Industrial CF Product Specifications



August 24, 2020

Version 1.2



Apacer Technology Inc.

1F, No.32, Zhongcheng Rd., Tucheng Dist., New Taipei City, Taiwan, R.O.C

Tel: +886-2-2267-8000 Fax: +886-2-2267-2261

www.apacer.com

Specifications Overview:

- **CompactFlash Association Specification Revision 6.1 Standard Interface**
 - ATA command set compatible
 - ATA transfer mode supports: PIO Mode 6, Multiword DMA Mode 4, Ultra DMA Mode 6 in True-IDE mode
- **Capacity**
 - 8, 16, 32, 64 GB
- **Performance***
 - Sequential read: Up to 115 MB/sec
 - Sequential write: Up to 80 MB/sec
 - Random read (4K): Up to 3,100 IOPS
 - Random write (4K): Up to 2,100 IOPS
- **Flash Management**
 - Global Wear Leveling
 - Built-in BCH ECC capable of correcting up to 96 bits in 1KB data
 - Supports S.M.A.R.T commands
 - Flash Block Management
 - Flash Translation Layer: Page Mapping
 - Power Failure Management
 - SLC-liteX
- **Reliability**
 - Supply voltage power-down detection for full power-down robustness
- **NAND Flash Type: 3D TLC (BiC3)**
- **MTBF: >1,000,000 hours**
- **Endurance (in drive writes per day: DWPD)**
 - 8 GB: 20.47 DWPD
 - 16 GB: 9.87 DWPD
 - 32 GB: 10.54 DWPD
 - 64 GB: 8.84 DWPD
- **Temperature Range**
 - Operating:
 - Standard: 0°C to 70°C
 - Wide: -40°C to 85°C
 - Storage: -40°C to 100°C
- **Supply Voltage**
 - 3.3V ± 5%
 - 5.0V ± 10%
- **Power Consumption***

Operating Voltage: 3.3V

 - Active mode: 185 mA
 - Standby mode: 10 mA

Operating Voltage: 5.0V

 - Active mode: 190 mA
 - Standby mode: 10 mA
- **Connector Type**
 - 50 pins female
- **Form Factor**
 - 36.4mm x 42.8mm x 3.3mm
 - Net Weight: 9.95 g ± 5%
- **Halogen Free**
- **RoHS Recast Compliant**
 - Complies with 2011/65/EU Standard

*Varies from capacities. The values for performances and power consumptions presented are typical and may vary depending on flash configurations or platform settings.

Table of Contents

1. General Descriptions	4
1.1 Intelligent Endurance Design	4
1.1.1 Error Correction Code (ECC).....	4
1.1.2 Global Wear Leveling	4
1.1.3 S.M.A.R.T. Technology.....	4
1.1.4 Flash Block Management	5
1.1.5 Flash Translation Layer – Page Mapping.....	5
1.1.6 Power Failure Management.....	6
1.1.7 SLC-liteX.....	6
2. Functional Block	7
3. Pin Assignments.....	8
4. Product Specifications.....	10
4.1 Capacity.....	10
4.2 Performance.....	10
4.3 Environmental Specifications	11
4.4 Mean Time Between Failures (MTBF).....	11
4.5 Certification and Compliance.....	11
4.6 Endurance	12
5. Software Interface	13
5.1 CF-ATA Command Set.....	13
6. Electrical Specifications.....	16
6.1 Operating Voltage.....	16
6.2 Power Consumption.....	16
6.3 AC/DC Characteristics	17
6.3.1 DC Characteristics	17
6.3.2 AC Characteristics	19
7. Physical Characteristics.....	23
7.1 Dimensions	23
7.2 Net Weight.....	23
8. Product Ordering Information.....	24

8.1 Product Code Designations	24
8.2 Valid Combinations	25

1. General Descriptions

Apacer's value-added Industrial CompactFlash Card offers high performance, high reliability and power-efficient storage. Regarding standard compliance, this CompactFlash Card complies with CompactFlash specification revision 6.1, supporting transfer modes up to Programmed Input Output (PIO) Mode 6, Multi-word Direct Memory Access (DMA) Mode 4, Ultra DMA Mode 6 in True-IDE Mode.

Apacer's value-added CFC provides complete PCMCIA – ATA functionality and compatibility. Apacer's CompactFlash technology is designed for applications in Point of Sale (POS) terminals, telecom, IP-STB, medical instruments, surveillance systems, industrial PCs and handheld applications such as the new generation of Digital Single Lens Reflex (DSLR) cameras.

1.1 Intelligent Endurance Design

1.1.1 Error Correction Code (ECC)

The CompactFlash card is programmed with BCH Error Detection Code (EDC) and Error Correction Code (ECC) algorithms capable of correcting up to 96 random bits in 1KB bytes data.

High performance is achieved through hardware-based error detection and correction.

1.1.2 Global Wear Leveling

Flash memory devices differ from Hard Disk Drives (HDDs) in terms of how blocks are utilized. For HDDs, when a change is made to stored data, like erase or update, the controller mechanism on HDDs will perform overwrites on blocks. Unlike HDDs, flash blocks cannot be overwritten and each P/E cycle wears down the lifespan of blocks gradually. Repeatedly program/erase cycles performed on the same memory cells will eventually cause some blocks to age faster than others. This would bring flash storages to their end of service term sooner. Global Wear leveling is an important mechanism that levels out the wearing of blocks so that the wearing-down of all blocks can be almost evenly distributed. This will increase the lifespan of SSDs.

1.1.3 S.M.A.R.T. Technology

S.M.A.R.T. is an acronym for Self-Monitoring, Analysis and Reporting Technology, an open standard allowing disk drives to automatically monitor their own health and report potential problems. It protects the user from unscheduled downtime by monitoring and storing critical drive performance and calibration parameters. Ideally, this should allow taking proactive actions to prevent impending drive failure. Apacer SMART feature adopts the standard SMART command B0h to read data from the drive. When the Apacer SMART Utility running on the host, it analyzes and reports the disk status to the host before the device is in critical condition.

Code	SMART Subcommand
D0h	READ DATA
D1h	READ ATTRIBUTE THRESHOLDS
D2h	ENABLE/DISABLE ATTRIBUTE AUTOSAVE
D4h	EXECUTE OFF-LINE IMMEDIATE
D5h	SMART READ LOG
D6h	SMART WRITE LOG
D8h	ENABLE OPERATIONS

Code	SMART Subcommand
D9h	DISABLE OPERATIONS
DAh	RETURN STATUS

General SMART attribute structure

Byte	Description
0	ID (Hex)
1 – 2	Status Flag
3	Value
4	Worst
5*-11	Raw Data

*Byte 5: LSB

SMART attribute ID list

ID (Hex)	Attribute Name
12 (0x0C)	Power Cycle Count
160 (0xA0)	Initial Bad Block Count
161 (0xA1)	Bad Block Count
162 (0xA2)	Spare Block Count
163 (0xA3)	Max. Erase Count
164 (0xA4)	Avg. Erase Count
241 (0xF1)	Total LBAs Written
242 (0xF2)	Total LBAs Read

1.1.4 Flash Block Management

Current production technology is unable to guarantee total reliability of NAND flash memory array. When a flash memory device leaves factory, it comes with a minimal number of initial bad blocks during production or out-of-factory as there is no currently known technology that produce flash chips free of bad blocks. In addition, bad blocks may develop during program/erase cycles. Since bad blocks are inevitable, the solution is to keep them in control. Apacer flash devices are programmed with ECC, block mapping technique and S.M.A.R.T to reduce invalidity or error. Once bad blocks are detected, data in those blocks will be transferred to free blocks and error will be corrected by designated algorithms.

1.1.5 Flash Translation Layer – Page Mapping

Page mapping is an advanced flash management technology whose essence lies in the ability to gather data, distribute the data into flash pages automatically, and then schedule the data to be evenly written. Page-level mapping uses one page as the unit of mapping. The most important characteristic is that each logical page can be mapped to any physical page on the flash memory device. This mapping algorithm allows different sizes of data to be written to a block as if the data is written to a data pool and it does not need to take extra operations to process a write command. Thus, page mapping is adopted to increase random access speed and improve SSD lifespan, reduce block erase frequency, and achieve optimized performance and lifespan.

1.1.6 Power Failure Management

Power Failure Management plays a crucial role when power supply becomes unstable. Power disruption may occur when users are storing data into the SSD, leading to instability in the drive. However, with Power Failure Management, a firmware protection mechanism will be activated to scan pages and blocks once power is resumed. Valid data will be transferred to new blocks for merging and the mapping table will be rebuilt. Therefore, data reliability can be reinforced, preventing damage to data stored in the NAND Flash.

1.1.7 SLC-liteX

SLC-liteX is based on 3D NAND technology. The firmware is carefully tweaked by our engineering team so as to offer the greatest number of P/E cycles in this format – 30,000, which is 10 times more than MLC or industrial 3D TLC. The longest lifespans are therefore available at reasonable cost.

2. Functional Block

The CompactFlash Card (CFC) includes a controller and flash media, as well as the CompactFlash standard interface. Figure 2-1 shows the functional block diagram.

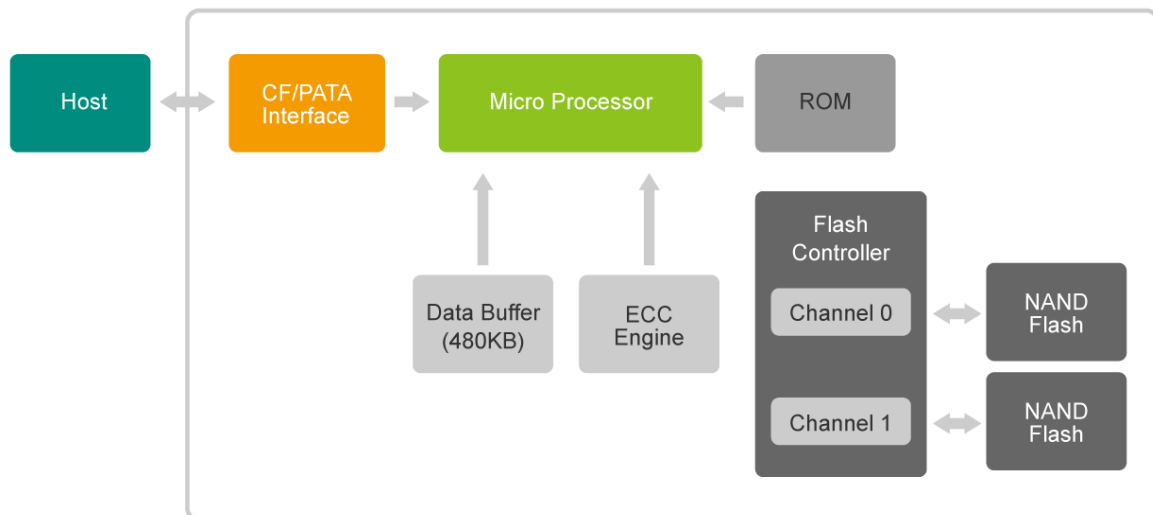

Figure 2-1 Functional Block Diagram

3. Pin Assignments

Table 3-1 lists the pin assignments with respective signal names for the 50-pin configuration. A “#” suffix indicates the active low signal. The pin type can be input, output or input/output.

Table 3-1 Pin Assignments

Pin No.	Memory card mode		I/O card mode		True IDE mode	
	Signal name	Pin I/O type	Signal name	Pin I/O type	Signal name	Pin I/O type
1	GND	-	GND	-	GND	-
2	D3	I/O	D3	I/O	D3	I/O
3	D4	I/O	D4	I/O	D4	I/O
4	D5	I/O	D5	I/O	D5	I/O
5	D6	I/O	D6	I/O	D6	I/O
6	D7	I/O	D7	I/O	D7	I/O
7	#CE1	I	#CE1	I	#CS0	I
8	A10	I	A10	I	A10 ¹	I
9	#OE	I	#OE	I	#ATA SEL	I
10	A9	I	A9	I	A9 ¹	I
11	A8	I	A8	I	A8 ¹	I
12	A7	I	A7	I	A7 ¹	I
13	VCC	-	VCC	-	VCC	-
14	A6	I	A6	I	A6 ¹	I
15	A5	I	A5	I	A5 ¹	I
16	A4	I	A4	I	A4 ¹	I
17	A3	I	A3	I	A3 ¹	I
18	A2	I	A2	I	A2	I
19	A1	I	A1	I	A1	I
20	A0	I	A0	I	A0	I
21	D0	I/O	D0	I/O	D0	I/O
22	D1	I/O	D1	I/O	D1	I/O
23	D2	I/O	D2	I/O	D2	I/O
24	WP	O	#IOIS16	O	#IOCS16	O
25	#CD2	O	#CD2	O	#CD2	O
26	#CD1	O	#CD1	O	#CD1	O
27	D11	I/O	D11	I/O	D11	I/O
28	D12	I/O	D12	I/O	D12	I/O
29	D13	I/O	D13	I/O	D13	I/O
30	D14	I/O	D14	I/O	D14	I/O
31	D15	I/O	D15	I/O	D15	I/O
32	#CE2	I	#CE2	I	#CS1	I
33	#VS1	O	#VS1	O	#VS1	O
34	#IORD	I	#IORD	I	#IORD	I
35	#IOWR	I	#IOWR	I	#IOWR	I
36	#WE	I	#WE	I	#WE	I
37	RDY/-BSY	O	#IREQ	O	INTRQ	O
38	VCC	-	VCC	-	VCC	-
39	#CSEL	I	#CSEL	I	#CSEL	I
40	#VS2	O	#VS2	O	#VS2	O
41	RESET	I	RESET	I	#RESET	I
42	#WAIT	O	#WAIT	O	IORDY	O
43	#INPACK	O	#INPACK	O	DMARQ ²	O
44	#REG	I	#REG	I	DMACK ²	I
45	BVD2	O	#SPKR	O	#DASP	I/O
46	BVD1	O	#STSCHG	O	#PDIAG	I/O

Pin No.	Memory card mode		I/O card mode		True IDE mode	
	Signal name	Pin I/O type	Signal name	Pin I/O type	Signal name	Pin I/O type
47	D8	I/O	D8	I/O	D8	I/O
48	D9	I/O	D9	I/O	D9	I/O
49	D10	I/O	D10	I/O	D10	I/O
50	GND	-	GND	-	GND	-

1. The signal should be grounded by the host.
2. Connection required when UDMA is in use.

4. Product Specifications

4.1 Capacity

Capacity specifications of the Compact Flash Card series (CFC) are available as shown in Table 4-1. It lists the specific capacity and the default numbers of heads, sectors and cylinders for each product line.

Table 4-1 Capacity Specifications

Capacity	Total bytes*	Cylinders	Heads	Sectors	Total LBA
8 GB	8,012,390,400	15,525	16	63	15,649,200
16 GB	16,013,942,784	16,383	16	63	31,277,232
32 GB	32,017,047,552	16,383	16	61	62,533,296
64 GB	64,023,257,088	16,383	16	63	125,045,424

Note:

Display of total bytes varies from operating systems.

Cylinders, heads or sectors are not applicable for these capacities. Only LBA addressing applies.

Notes: 1 GB = 1,000,000,000 bytes; 1 sector = 512 bytes.

LBA count addressed in the table above indicates total user storage capacity and will remain the same throughout the lifespan of the device. However, the total usable capacity of the SSD is most likely to be less than the total physical capacity because a small portion of the capacity is reserved for device maintenance usages.

4.2 Performance

Performance of the CF cards is listed in Table 4-2.

Table 4-2 Performance Specifications

Performance	Capacity	8 GB	16 GB	32 GB	64 GB
	Sequential Read* (MB/s)		90	115	115
Sequential Write* (MB/s)		38	75	80	80
Random Read IOPS** (4K)		3,100	3,100	3,100	3,000
Random Write IOPS** (4K)		1,300	1,900	2,000	2,100

Note:

Results may differ from various flash configurations or host system setting.

*Sequential performance is based on CrystalDiskMark 5.2.1 with file size 1,000MB.

**Random performance measured using IOMeter with Queue Depth 32.

4.3 Environmental Specifications

Environmental specifications of the Compact Flash Card series (CFC) are shown in Table 4-3.

Table 4-3 Environmental Specifications

Item	Specifications
Operating temp.	0°C to 70°C (Standard); -40°C to 85°C (Wide)
Non-operating temp.	-40°C to 100°C
Operating vibration	7.69 GRMS, 20~2000 Hz/random (compliant with MIL-STD-810G)
Non-operating vibration	4.02 GRMS, 15 ~ 2000 Hz/sine (compliant with MIL-STD-810G)
Operating shock	50G, 11ms, half-sine wave
Non-operating shock	1,500G, 0.5ms, half-sine wave

4.4 Mean Time Between Failures (MTBF)

MTBF, an acronym for Mean Time Between Failures, is a measure of a device’s reliability. Its value represents the average time between a repair and the next failure. The measure is typically in units of hours. The higher the MTBF value, the higher the reliability of the device. The predicted result of this CompactFlash Card is higher than 1,000,000 hours.

4.5 Certification and Compliance

The CompactFlash card complies with the following global standards:

- CE
- FCC
- Halogen-free
- EMC
- RoHS Recast (2011/65/EU)

4.6 Endurance

The endurance of a storage device is predicted by Drive Writes Per Day based on several factors related to usage, such as the amount of data written into the drive, block management conditions, and daily workload for the drive. Thus, key factors, such as Write Amplifications and the number of P/E cycles, can influence the lifespan of the drive.

Table 4-4 Drive Writes Per Day

Capacity	Drive Writes Per Day
8 GB	20.47
16 GB	9.87
32 GB	10.54
64 GB	8.84

Note:

- This estimation complies with JEDEC JESD-219, enterprise endurance workload of sequential data with payload size distribution.
- Flash vendor guaranteed 3D TLC SLC-liteX P/E cycle: 30K
- WAF may vary from capacity, flash configurations and writing behavior on each platform.
- 1 Terabyte = 1,024 GB
- DWPD (Drive Write Per Day) is calculated based on the number of times that user overwrites the entire capacity of an SSD per day of its lifetime during the warranty period. (SLC-liteX warranty: 5 years)

5. Software Interface

5.1 CF-ATA Command Set

Table 5-1 summarizes the CF-ATA command set with the paragraphs that follow describing the individual commands and the task file for each.

Table 5-1 CFC-ATA Command Set

Command Set	Command	Code	Protocol
CFA Feature Set	Request Sense	03h	Non-data
	Write Sectors Without Erase	38h	PIO data-out
	Erase Sectors	C0h	Non-data
	Write Multiple Without Erase	CDh	PIO data-out
	Translate Sector	87h	PIO data-in
	Write Multiple w/o erase	CDh	PIO
	Write sector(s) w/o erase	38h	PIO
General Feature Set	Execute Drive Diagnostic	90h	Device diagnostic
	Flush Cache	E7h	Non-data
	Identify Device	ECh	PIO data-in
	Read DMA	C8h	DMA
	Read Multiple	C4h	PIO data-in
	Read Sector(s)	20h or 21h	PIO data-in
	Read Verify Sector(s)	40h or 41h	Non-data
	Set Feature	EFh	Non-data
	Set Multiple Mode	C6h	Non-data
	Write DMA	CAh	DMA
	Write Multiple	C5h	PIO data-out
	Write Sector(s)	30h or 31h	PIO data-out
	NOP	00h	Non-data
	Read Buffer	E4h	PIO data-in
	Write Buffer	E8h	PIO data-out
	Set Feature	EFh	Non-data
Power Management Feature Set	Check Power Mode	E5h or 98h	Non-data
	Idle	E3h or 97h	Non-data
	Idle Immediate	E1h or 95h	Non-data
	Set sleep mode	E6h or 99h	Non-data
	Sleep	E6h or 99h	Non-data
	Standby	E2h or 96h	Non-data

Command Set	Command	Code	Protocol
	Standby Immediate	E0h or 94h	Non-data
Security Mode Feature Set	Security Set Password	F1h	PIO data-out
	Security Unlock	F2h	PIO data-out
	Security Erase Prepare	F3h	Non-data
	Security Erase Unit	F4h	PIO data-out
	Security Freeze Lock	F5h	Non-data
	Security Disable Password	F6h	PIO data-out
	Media Lock	DEh	Non-data
	Media Unlock	DFh	Non-data
SMART Feature Set	SMART Disable Operations	B0h	Non-data
	SMART Enable/Disable Autosave	B0h	Non-data
	SMART Enable Operations	B0h	Non-data
	SMART Return Status	B0h	Non-data
	SMART Execute Off-line Immediate	B0h	Non-data
	SMART Read Data	B0h	PIO data-in
Host Protected Area Feature Set	Data Set Management	06h	DMA
	Read Native Max Address	F8h	Non-data
	Read native max addr Ext	27h	Non-data
	Set Max Address	F9h	Non-data
Others	Format Track	50h	PIO data-out
	Initialize Drive Parameters	91h	Non-data
	Recalibrate	1Xh	Non-data
	Seek	7Xh	Non-data
	Write Verify	3Ch	PIO data-out
	Download Microcode	92h	PIO data-in
	Download Microcode DMA	93h	DMA
48-bit Address Feature Set	Read Sector Ext	24h	PIO data-in
	Read DMA Ext	25h	DMA
	Read Multiple Ext	29h	PIO data-in
	Write Sector Ext	34h	PIO data-out
	Write DMA Ext	35h	DMA
	Read Verify Sector Ext	42h	Non-data
	Write Multiple FUA Ext	CEh	PIO data-out
	Flush Cache Ext	EAh	Non-data
	Read Log Ext	2Fh	PIO
Read Log DMA Ext	57h	DMA	

Command Set	Command	Code	Protocol
	Write DMA FUA Ext	3Dh	DMA
	Write Log Ext	3Fh	PIO
	Write Log DMA Ext	57h	DMA
	Write Multiple Ext	39h	PIO
	Set max address Ext	37h	Non-data

6. Electrical Specifications

6.1 Operating Voltage

Table 6-1 lists the supply voltage for the CompactFlash card.

Table 6-1 Operating Range

Item	Range
Supply voltage at 3.3V	3.135 to 3.465 V
Supply voltage at 5V	4.75 to 5.25 V

6.2 Power Consumption

Table 6-2 and 6-3 list the power consumption for the CompactFlash card.

Table 6-2 Power Consumption @3.3V

Capacity Mode	8 GB	16 GB	32 GB	64 GB
Active (mA)	150	175	180	185
Standby (mA)	10	10	10	10

Table 6-3 Power Consumption @5V

Capacity Mode	8 GB	16 GB	32 GB	64 GB
Active (mA)	150	180	190	190
Standby (mA)	10	10	10	10

Note:

*All values are typical and may vary depending on flash configurations or host system settings.

**Active power is an average power measurement performed using CrystalDiskMark with 128KB sequential read/write transfers.

6.3 AC/DC Characteristics

The following section provides general AC/DC characteristics of this CompactFlash card.

6.3.1 DC Characteristics

- Absolute Maximum Ratings**

Parameter	Remark
Supply voltage on 3.3V supply pins	-0.5V to 3.63V
Supply voltage on 1.2V supply pins	-0.5V to 1.32V
Voltage on CF/PATA pins with respect to ground	-0.5V to 6.7V
Voltage on flash pins with respect to ground	-0.5V to VDDF + 0.5V
Voltage on GPIO8..15 pins with respect to ground	-0.5V to + 0.5V
Voltage on other pins with respect to ground	-0.5V to VCC + 0.5V
Storage temperature	-40°C to 125°C

- DC Parameters**

Parameter	Remark
Supply Voltage VCC, AVCC	3.30V ± 5%
Supply Voltage VDDF	3.30V ± 5%, 1.80V ± 5%
Supply Voltage VDDC, AVDDC	1.2V ± 5%
Temperature (ambient)	-40°C to 85°C (industrial)

- General DC characteristics**

Symbol	Parameter	Min	Max	Unit	Remark
V _{IL, H}	Input LOW Voltage	-0.3	0.8	V	CF/PATA host interface
V _{IH, H}	Input HIGH Voltage	2.0	5.5	V	
V _{IL}	Input LOW Voltage	-0.3	0.3*V _{DD}	V	V _{DD} is VDDF (flash IF) or VCC (other pins)
V _{IH}	Input HIGH Voltage	0.7*V _{DD}	*V _{DD} +0.3	V	
V _{OL}	Output LOW Voltage		0.4	V	at 4mA (12mA for DASP)
V _{OH, H}	Output HIGH Voltage	VCC-0.51		V	at 6mA, CF/PATA pins
V _{OH}	Output HIGH Voltage	V _{DD} -0.4		V	at 4mA, other pins
I _{LI}	Input Leakage Current	-5	5	µA	if not pull-up/pull-down
I _{LO}	Output Leakage Current	-5	5	µA	if not pull-up/pull-down
I _{PURB33}	Pull-Up Current	1.5	2.5	mA	F _n RB0..3 pins, at 3.3V
I _{PURB18}	Pull-Up Current	0.6	1.4	mA	F _n RB0..3 pins, at 1.8V
I _{PU}	Pull-Up Current	15	110	µA	other pins
I _{PD}	Pull-Down Current	20	160	µA	
C _{IO}	Input/Output Capacitance		10	pF	
ESD	ESD Protection	2		kV	HBM

• **Operating Currents**

Symbol	Parameter	Typ	Max	Unit	Remark
I _{VCC}	VCC current				
	Sleep mode	3.0	4.5	mA	
	Operating	15	85	mA	in UDMA6 mode
I _{VDDC}	VDDC current				at 25°C
	Sleep mode	1	6	mA	
	Operating	50	80	mA	at 160 MHz CPU clock
I _{VDDF}	VDDF current				at 80 MHz flash clock, typical CF card PCB
	at 1.8V	8	25	mA	
	at 3.3V	15	60	mA	
I _{AVCC}	AVCC current	0.4	0.6	mA	
I _{AVDDC}	AVDDC current				
	Sleep mode	20	200	μA	
	Operating	4.5	14.0	mA	typ for 400 MHz PLL

• **Voltage Regulator Parameters**

1.2V switching regulator (supply for VDDC)

Symbol	Parameter	Min	Typ	Max	Unit	Remark
V _I	Input voltage (CIN)	3.00	3.30	3.60	V	
V _O	Output voltage	1.15	1.20	1.25	V	
I _O	Average load current			600	mA	
V _{R20}	Output ripple 20 MHz BW			15	mV	
T _{on}	Startup time		50		μS	
L _O	Output filtering inductor		2.2		μH	
C _O	Output filtering capacitor		2x10		μF	2 capacitors
ESR	Output capacitor ESR	2		200	mΩ	
ESL	Output capacitor ESL			4	nH	

1.8V linear regulator (supply for VDDF)

Symbol	Parameter	Min	Typ	Max	Unit	Remark
V _I	Input voltage (FIN)	3.00	3.30	3.60	V	
V _O	Output voltage (FOUT)	1.72	1.80	1.88	V	
I _O	Average load current			150	mA	
T _{on}	Startup time		10		μS	
C _O	Output filtering capacitor		2.2		μF	
ESR	Output capacitor ESR	4		200	mΩ	
ESL	Output capacitor ESL			4	nH	

• **SLEVCC Switchable ISO7816 Power Supply Output Parameters**

Symbol	Parameter	Min	Typ	Max	Unit	Remark
V _{SLE}	SLEVCC Output Voltage	VCC -0.2		VCC	V	When enabled
I _{SLE}	SLEVCC Output Current			30	mA	
T _{SLE}	SLEVCC Ramp Up Time		10		μS	
C _{SLE}	SLEVCC Output Capacitor		0.1		μF	

● **Supply Voltage Monitor Parameters**

Symbol	Parameter	Min	Typ	Max	Unit	Remark
ReS _{1.2R}	1.2V Reset rising threshold		95		%	of 1.2V regulator output
ReS _{3.3R}	3.3V Reset rising threshold	2.23	2.35	2.47	V	at VCC pin
ReS _{3.3F}	3.3V Reset falling threshold	2.15	2.20	2.25	V	at VCC pin
S _{5VH}	5V sense high threshold	4.31	4.40	4.49	V	at SENSE5V pin
S _{5VL}	5V sense low threshold	3.01	3.07	3.13	V	at SENSE5V pin
S _{3V}	3.3V sense threshold	2.84	2.90	2.96	V	at SENSE3V pin

The ReS_{1.2R} and ReS_{3.3R} thresholds are used by the reset logic to release the internal reset signal on a system power-on. The ReS_{3.3L} threshold is used to assert the internal reset signal on a system power down.

The S_{3V} and S_{5V} threshold comparators generate interrupts to the firmware. The S_{3V} comparator normally monitors the 3.3V VCC supply, the S_{5V} comparator normally monitors the 5V or 3.3V module supply. The S_{3V} interrupt can be used to stop accesses to the flash memory early on a system power down event. The S_{5V} interrupt can be used to implement a supply hold-up functionality when a backup energy source is available.

In packages that do not have the SENSE3V pin, SENSE3V is internally connected to VCC.

6.3.2 AC Characteristics

The AC Characteristics reference the timing diagrams of the CompactFlash Specification Revision 4.1 and the symbols in these timing diagrams. The AC characteristics are valid for a supply voltage of 3.3V ± 5%.

● **Attribute Memory Read and Write Characteristics**

See figures 25 and 26 in the CF Specification Revision 4.1.

Symbol	Parameter	Min	Max	Unit
tc(R)	Read cycle time	250		ns
ta(A)	Address access time		250	ns
ta(CE)	Card Enable access time		250	ns
ta(OE)	Output Enable access time		125	ns
tdis(CE)	Output disable time from CE		100	ns
tdis(OE)	Output disable time from OE		100	ns
ten(CE)	Output enable time from CE	5		ns
ten(OE)	Output enable time from OE	5		ns
tv(A)	Data valid time from address change	0		ns
tsu(A)	Address setup time	30		ns
tc(W)	Write cycle time	250		ns
tw(WE)	Write pulse time	150		ns
trec(WE)	Address hold time from WE	30		ns
tsu(D-WEH)	Data setup time for WE	80		ns
th(D)	Data hold time	30		ns

● **Common Memory Read and Write Characteristics**

See figures 27 and 28 in the CF Specification Revision 4.1. The wait functionality is not used.

Symbol	Parameter	Min	Max	Unit
tc	Cycle time	80		ns
ta(OE)	Output Enable access time		45	ns
tdis(OE)	Output disable time from OE		45	ns
tsu(A)	Address setup time	10		ns
th(A)	Address hold time	10		ns
tsu(CE)	Card Enable setup time	0		ns
th(CE)	Card Enable hold time	10		ns
tw(WE)	Write pulse time	55		ns
tsu(A)	Address setup time for WE	10		ns
tsu(CE)	Card Enable setup time for WE	0		ns
tsu(D-WEH)	Data setup time for WE	30		ns
th(D)	Data hold time	10		ns
trec(WE)	Write recovery time	15		ns

● **I/O Access Read and Write Characteristics**

See figures 29 and 30 in the CF Specification Revision 4.1. The wait functionality is not used.

Symbol	Parameter	Min	Max	Unit
td(IORD)	Data delay after IORD		45	ns
th(IORD)	Data hold following IORD	5		ns
tw(IORD)	IORD pulse width	55		ns
tsuA(IORD)	Address setup time for IORD	15		ns
thA(IORD)	Address hold time from IORD	10		ns
tsuCE(IORD)	Card Enable setup time for IORD	5		ns
thCE(IORD)	Card Enable hold time from IORD	10		ns
tsuREG(IORD)	REG setup time for IORD	5		ns
thREG(IORD)	REG hold time from IORD	0		ns
tdfINPACK(IORD)	INPACK delay falling from IORD	0	45	ns
tdrINPACK(IORD)	INPACK delay rising from IORD		45	ns
tdfIOIS16(ADR)	IOIS16 delay falling from address		35	ns
tdrIOIS16(ADR)	IOIS16 delay rising from address		35	ns
tsu(IOWR)	Data setup time for IOWR	15		ns
th(IOWR)	Data hold time from IOWR	5		ns
tw(IOWR)	IOWR pulse width	55		ns
tsuA(IOWR)	Address setup time for IOWR	15		ns
thA(IOWR)	Address hold time from IOWR	10		ns
tsuCE(IOWR)	Card Enable setup time for IOWR	5		ns
thCE(IOWR)	Card Enable hold time from IOWR	10		ns
tsuREG(IOWR)	REG setup time for IOWR	5		ns
thREG(IOWR)	REG hold time from IOWR	0		ns

- **True-IDE PIO Mode Read and Write Characteristics**

See figure 31 in the CF Specification Revision 4.1. The IORDY functionality is not used.

Symbol	Parameter	Min	Max	Unit
t0	Cycle time	80		ns
t1	Address setup time for IORD/IOWR	10		ns
t9	Address hold time from IORD/IOWR	10		ns
t2	IORD/IOWR pulse width	55		ns
t2i	IORD/IOWR recovery time	20		ns
t5	Data setup time for IORD	10		ns
t6	Data hold following IORD	5		ns
t6z	Output disable time from IORD		20	ns
t3	Data setup time for IOWR	15		ns
t4	Data hold following IOWR	5		ns

- **True-IDE MDMA Mode Read and Write Characteristics**

See figure 32 in the CF Specification Revision 4.1.

Symbol	Parameter	Min	Max	Unit
tO	Cycle time	80		ns
tD	IORD/IOWR pulse width	55		ns
tE	IORD data access		45	ns
tF	Data hold following IORD	5		ns
tG	Data setup time for IORD/IOWR	10		ns
tH	Data hold following IOWR	5		ns
tI	DMACK setup time for IORD/IOWR	0		ns
tJ	DMACK hold following IORD/IOWR	5		ns
tKR, tKW	IORD/IOWR recovery time	20		ns
tLR, tLW	IORD/IOWR to DMARQ delay		35	ns
tM	CS0, CS1 setup for IORD/IOWR	5		ns
tN	CS0, CS1 hold following IORD/IOWR	10		ns
tZ	Output disable time from DMACK		25	ns

- **True-IDE UDMA Mode Read and Write Characteristics**

The interface timing in the True-IDE UDMA modes is not only depending on the interface hardware, but also on the correct setup of the UDMA registers in the firmware, according to the UDMA transfer mode selected by the host. With a correct register setup, the interface timing complies to the UDMA Mode 0 to Mode 7 timing specifications of the CF Specification Revision 6.1, and to the UDMA Mode 0 to Mode 6 timing specifications of the ATA/ATAPI-7 Standard.

- **Toggle Mode Flash Memory Interface Characteristics**

The AC Characteristics for the flash memory interface are based on the F9 flash interface clock cycle time. τ is $\frac{1}{2}$ of the flash interface clock cycle time configured in the preformat. In Toggle mode, the valid range for τ is 5ns to 10ns. The table lists the flash memory interface timing based on τ , valid for a load of not more than 45pF on the flash interfacepins.

Symbol	Parameter	Min	Typ	Max	Unit
t _{CALS}	CLE, ALE setup time	6 τ - 2			ns
t _{CALH}	CLE, ALE hold time	1.5 τ - 2			ns
t _{CS}	CE# setup time	6 τ - 2			ns
t _{CH}	CE# hold time	1.5 τ - 2			ns
t _{CAS}	Data (command/address) setup time	2.5 τ - 2			ns
t _{CAH}	Data (command/address) hold time	1.5 τ - 2			ns
t _{WC}	Write cycle time	7.5 τ			ns
t _{WP}	WE# low pulse width	4 τ - 2			ns
t _{WH}	WE# high pulse width	4 τ - 2			ns
t _{DSC}	DQS cycle time		2 τ		ns
t _{DQSH}	DQS high time	0.94 τ			ns
t _{DQSL}	DQS low time	0.94 τ			ns
t _{DS}	Data output setup time to DQS	0.5 τ - 1.5			ns
t _{DH}	Data output hold time from DQS	0.5 τ - 1.5			ns
t _{RC}	Read cycle time		2 τ		ns
t _{RP}	RE# low pulse width	0.94 τ			ns
t _{REH}	RE# high pulse width	0.94 τ			ns
t _{DQSQ}	DQS to input data skew			0.5 τ - 1.6	ns
t _{QH}	Input data hold from DQS	0.5 τ + 0.8			ns

● **ONFI-2 Mode Flash Memory Interface Characteristics**

The AC Characteristics for the flash memory interface are based on the F9 flash interface clock cycle time. τ is ½ of the flash interface clock cycle time configured in the preformat. In ONFI-2 mode, the valid range for τ is 5ns to 10ns. The table lists the flash memory binterface timing based on τ, valid for a load of not more than 45pF on the flash interface pins.

Symbol	Parameter	Min	Typ	Max	Unit
t _{CK}	Average clock cycle time		2 τ		ns
t _{CKH}	Clock high time	0.94 τ		1.06 τ	ns
t _{CKL}	Clock low time	0.94 τ		1.06 τ	ns
t _{CALS}	ALE, CLE, W/R# setup time to CLK	τ - 3			ns
t _{CALH}	ALE, CLE, W/R# hold time from CLK	τ - 3			ns
t _{CS}	CE# setup time to CLK	5 τ - 3			ns
t _{CH}	CE# hold time from CLK	τ - 3			ns
t _{CAS}	Data output setup time to CLK	τ - 3			ns
t _{CAH}	Data output hold time from CLK	τ - 3			ns
t _{DQSS}	DQS phase	2 τ - 2		2 τ + 2	ns
t _{DQSH}	DQS high time	0.94 τ		1.06 τ	ns
t _{DQSL}	DQS low time	0.94 τ		1.06 τ	ns
t _{DS}	Data output setup time to DQS	0.5 τ - 1.5			ns
t _{DH}	Data output hold time from DQS	0.5 τ - 1.5			ns
t _{DQSQ}	DQS to input data skew			0.5 τ - 1.6	ns
t _{QH}	Input data hold from DQS	0.5 τ + 0.8			ns

7. Physical Characteristics

7.1 Dimensions

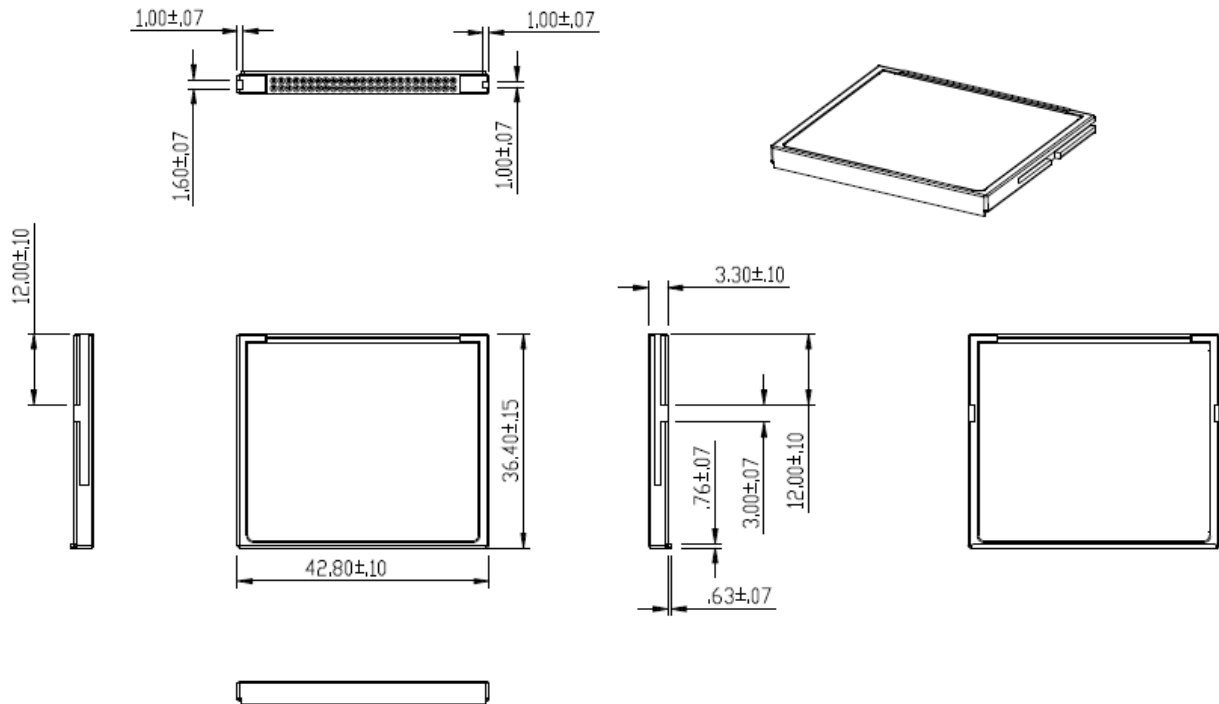

Figure 7-1 Physical Dimensions.

Unit: mm

7.2 Net Weight

Table 7-1 Net Weight

Capacity	Net Weight (g ± 5%)
8 GB	8.38
16 GB	8.92
32 GB	9.95
64 GB	9.95

8. Product Ordering Information

8.1 Product Code Designations

Code	1	2	3	4	5	6	7	8	9	10	11	12	13	14	15	16
	A	G	2	.	7	1	8	X	X	A	.	X	X	X	0	1

Code 1-3 (Product Line & Form Factor)	MDC+CF Card
Code 5-6 (Model/Solution)	HyperStone F9
Code 7-8 (Product Capacity)	8F: 8GB (SLC-liteX) 8G: 16GB (SLC-liteX) 8H: 32GB (SLC-liteX) 8J: 64GB (SLC-liteX)
Code 9 (Flash Type & Product Temp)	L: 3D SLC-liteX Standard temperature M: 3D SLC-liteX Wide temperature
Code 10 (Product Spec)	A: Non-Removable
Code 12-14 (Version Number)	Random numbers generated by system
Code 15-16 (Firmware Version)	01: CFHA001C

8.2 Valid Combinations

Capacity	Standard Temperature	Wide Temperature
8GB	AG2.718FLA.00101	AG2.718FMA.00101
16GB	AG2.718GLA.00101	AG2.718GMA.00101
32GB	AG2.718HLA.00101	AG2.718HMA.00101
64GB	AG2.718JLA.00101	AG2.718JMA.00101

Note: Valid combinations are those products in mass production or will be in mass production. Consult your Apacer sales representative to confirm availability of valid combinations and to determine availability of new combinations.

Revision History

Revision	Description	Date
1.0	Initial release	3/19/2020
1.1	Updated product photo on the cover page	3/26/2020
1.2	Removed VDDG from 6.3.1 DC Characteristics	8/24/2020

Global Presence

Taiwan (Headquarters)

Apacer Technology Inc.

1F., No.32, Zhongcheng Rd., Tucheng Dist.,
New Taipei City 236, Taiwan R.O.C.
Tel: 886-2-2267-8000
Fax: 886-2-2267-2261
amtsales@apacer.com

Japan

Apacer Technology Corp.

6F, Daiyontamachi Bldg., 2-17-12, Shibaura, Minato-Ku,
Tokyo, 108-0023, Japan
Tel: 81-3-5419-2668
Fax: 81-3-5419-0018
jpservices@apacer.com

China

Apacer Electronic (Shanghai) Co., Ltd

Room D, 22/FL, No.2, Lane 600, JieyunPlaza,
Tianshan RD, Shanghai, 200051, China
Tel: 86-21-6228-9939
Fax: 86-21-6228-9936
sales@apacer.com.cn

U.S.A.

Apacer Memory America, Inc.

46732 Lakeview Blvd., Fremont, CA 94538
Tel: 1-408-518-8699
Fax: 1-510-249-9551
sa@apacerus.com

Europe

Apacer Technology B.V.

Science Park Eindhoven 5051 5692 EB Son,
The Netherlands
Tel: 31-40-267-0000
Fax: 31-40-290-0686
sales@apacer.nl

India

Apacer Technologies Pvt Ltd,

1874, South End C Cross, 9th Block Jayanagar,
Bangalore-560069, India
Tel: 91-80-4152-9061/62
Fax: 91-80-4170-0215
sales_india@apacer.com