

RoHS Compliant

CFast

Product Specifications

June 25th, 2013

Version 1.2



Apacer Technology Inc.

4th Fl., 75 HsinTai Wu Rd., Sec.1, Xizhi, New Taipei City, Taiwan 221

Tel: +886-2-2698-2888 Fax: +886-2-2698-2889

www.apacer.com

Features:

- **Standard Serial ATA 2.6 (Gen. 2)**
 - SATA II, 3.0 Gbps
 - ATA-compatible command set
 - ATA modes support
- **Connector type**
 - 7 + 17 pin female connector
- **Power consumption (typical)****
 - Supply voltage: 3.3V
 - Active mode: 315 mA
 - Idle mode: 85 mA
- **Performance****
 - Sustained read: Up to 160 MB/sec
 - Sustained write: Up to 85 MB/sec
- **Capacity**
 - 8, 16, 32, 64, 128 GB
- **NAND Flash Type: MLC**
- **MTBF: >1,000,000 hours**
- **Temperature ranges**
 - Operation:
 - Standard: 0 °C to 70 °C
 - Extended*: -40 °C to 85 °C
 - Storage: -40 °C to 100 °C
- **Intelligent endurance design**
 - Built-in hardware ECC, enabling up to 16/24 bit correction per 1K bytes
 - Dynamic/Static wear-leveling scheme together with dynamical block allocation to significantly increase the lifetime of a flash device and optimize the disk performance
 - Flash bad-block management
 - S.M.A.R.T.
 - Power Failure Management
 - ATA Secure Erase
 - TRIM
- **RoHS Compliant**

*Extended temperature is available from 16 to 128GB capacities.

**Vary from capacities. The values presented in Power consumption and Performances are typical, and may vary depending on different settings and platforms.

Table of Contents

1. GENERAL DESCRIPTION	3
2. FUNCTIONAL BLOCK	3
3. PIN ASSIGNMENTS	4
4. PRODUCT SPECIFICATION	6
4.1 CAPACITY	6
4.2 PERFORMANCE	6
4.3 ENVIRONMENTAL SPECIFICATIONS	7
4.4 MEAN TIME BETWEEN FAILURES (MTBF)	7
4.5 CERTIFICATION AND COMPLIANCE	7
5. FLASH MANAGEMENT	8
5.1 ERROR CORRECTION/DETECTION	8
5.2 BAD BLOCK MANAGEMENT	8
5.3 WEAR LEVELING	8
5.4 POWER FAILURE MANAGEMENT	8
5.5 ATA SECURE ERASE	8
5.6 S.M.A.R.T.	9
5.7 TRIM	9
6. SOFTWARE INTERFACE	10
6.1 ATA COMMAND SET	10
7. ELECTRICAL SPECIFICATION	11
7.1 OPERATING VOLTAGE	11
7.2 POWER CONSUMPTION	11
8. PHYSICAL CHARACTERISTICS	12
8.1 DIMENSIONS	12
9. PRODUCT ORDERING INFORMATION	13
9.1 PRODUCT CODE DESIGNATIONS	13

1. General Description

CFast emerges as the evolution of the CompactFlash card, by adopting SATA transfer bus rather than PATA, which delivers a much higher data transfer rate required in industrial and enterprise storage usages. Although not backward compatible with its former CF form factor, CFast proves to be a more advanced embedded solution for cache, storage acceleration, communication and networking applications that require small physical fit.

Apacer CFast is designed with a powerful controller that easily breaks the performance limit for CompactFlash by delivering the transfer rate up to 160 MB/s while maintaining the reliability and power efficiency inherited from its former. Leveraging from CompactFlash form factor and SATA interface, CFast can be integrated into host computing system without excessive BIOS configurations and driver installations.

In addition to its performance, Apacer CFast is designed with reliability and data integrity. The CFast card adopts static wear-leveling to average the use of all flash blocks to prolong the lifetime and improve block efficiency of flash media. A built-in powerful ECC engine operates at hardware level for error correction and detection. With its well-organized architecture, CFast is an ideal storage device for industrial, enterprise and mobile applications.

2. Functional Block

Apacer CFast includes a single-chip SATA II Controller and the flash media. The controller integrates the flash management unit to support multi-channel, multi-bank flash arrays. Figure 2-1 shows the functional block diagram.

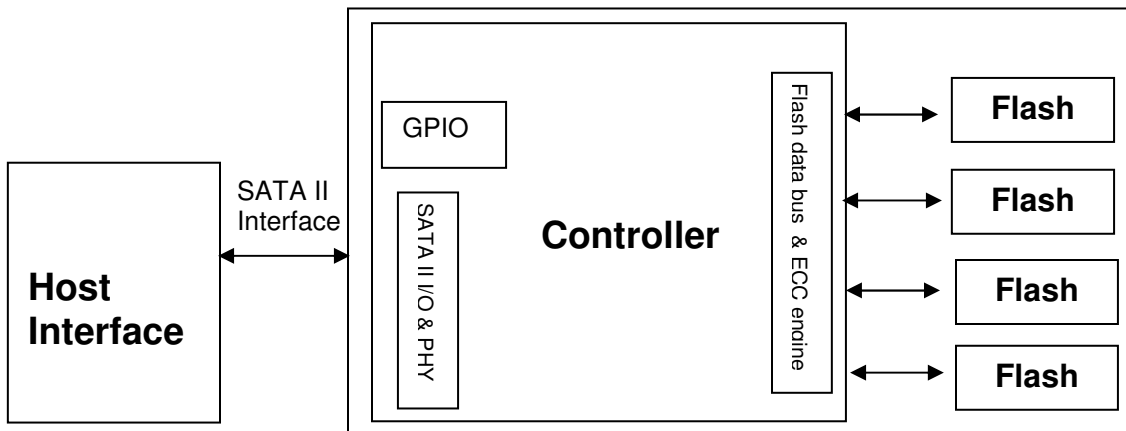

Figure 2-1 Apacer CFast block diagram

3. Pin Assignments

Table 3-1 describes CFAST signal segment, and Table 3-2, its power segment.

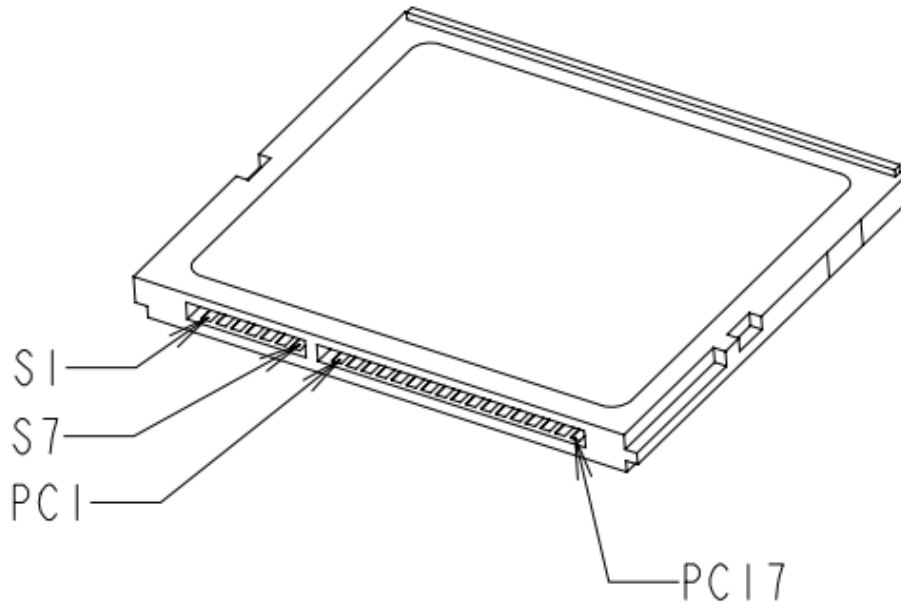

Figure 3-1 Pin Assignment

Table 3-1: Signal segment

PinC	Type	Description
S1	GND	
S2	A+	SATA Differential Signal Pair A
S3	A-	
S4	GND	
S5	B-	SATA Differential Signal Pair B
S6	B+	
S7	GND	

Table 3-2: Power segment

Pin	Name	Type	Description
PC1	CDI	CMOS Input	Card Detect In
PC2	GND	Device GND	
PC3	TBD	TBD	
PC4	TBD	TBD	
PC5	TBD	TBD	
PC6	TBD	TBD	
PC7	GND	Device GND	
PC8*	LED1	LED Output	Ready
PC9*	LED2	LED Output	Access
PC10	IO1	CMOS I/O	Reserved I/O
PC11	IO2	CMOS I/O	Write Protect**
PC12	IO3	CMOS I/O	Reserved I/O
PC13	PWR	3.3V	Device Power (3.3V)
PC14	PWR	3.3V	Device Power (3.3V)
PC15	PGND	Device GND	Device GND
PC16	PGND	Device GND	Device GND
PC17	CDO	CMOS Output	Card Detect Out

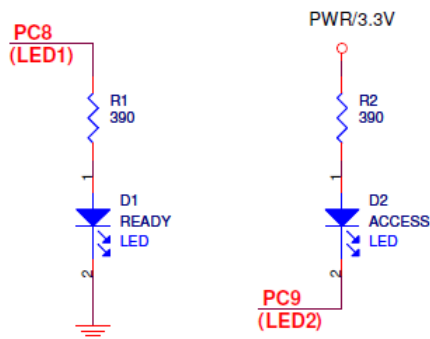

*Refer above for LED output design guide

**Enabled by adjusting the pin "PC11" from high to low active

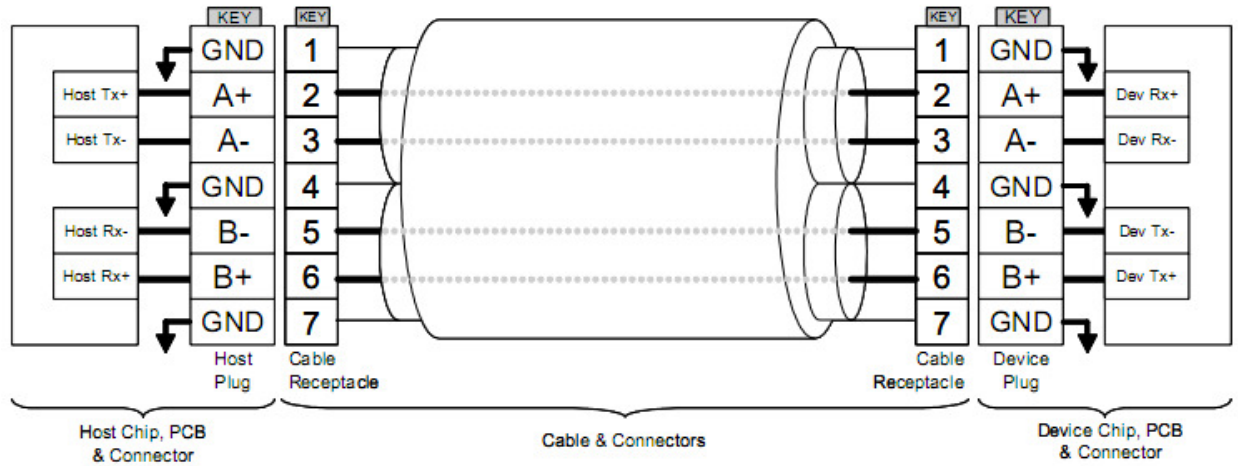

Figure 3-2 SATA Cable / Connector Connection Diagram

The connector on the left represents the Host with TX/RX differential pairs connected to a cable while the connector on the right shows the Device with TX/RX differential pairs also connected to the cable. Notice also the ground path connecting the shielding of the cable to the Cable Receptacle.

4. Product Specification

4.1 Capacity

Capacity specification table lists out unformatted, out-of-box capacities.

Table 4-1: Capacity specifications

Capacity	Total bytes*	Cylinders	Heads	Sectors	Max LBA
8 GB	8,012,390,400	15525	16	63	15,649,200
16 GB	16,013,942,784	16383	16	63	31,277,232
32 GB	32,017,047,552	16383	16	63	62,533,296
64 GB	64,023,257,088	16383	16	63	125,045,424
128 GB	126,718,694,912	16383	16	63	247,497,451

*Display of total bytes varies from file systems.

**Cylinders, heads or sectors are not applicable for these capacities. Only LBA addressing applies

LBA count addressed in the table above indicates total user storage capacity and will remain the same throughout the lifespan of the device. However, the total usable capacity of the CFast is most likely to be less than the total physical capacity because a small portion of the capacity is reserved for device maintenance usages.

4.2 Performance

Performance of CFast product family is available as shown in Table 4-2.

Table 4-2: Performance table

Capacity \ Performance	8 GB	16 GB	32 GB	64 GB	128 GB
Sustained Read (MB/s)	120	120	145	160	160
Sustained Write (MB/s)	25	25	40	85	85

Note: Performances results are measured by CrystalDiskMark under Windows XP SP3 and may vary from host system configurations.

4.3 Environmental Specifications

Environmental specification of the CFast follows the MIL-STD-810F testing standards, shown in Table 4-3.

Table 4-3 Environmental specification

Environment		Specification
Temperature	Operation	0°C to 70°C (Standard); -40°C to 85°C (Extended Temperature)
	Storage	-40°C to 100°C
Vibration*		Sine wave : 10~2000Hz, 15G (X, Y, Z axis)
Shock*		Half sine wave, 1500 G (X, Y, Z ; All 6 axis)

*Non-operating

Note:

-This Environmental Specification table indicates the conditions for testing the device. Real world usages may affect the results.

-Extended temperature is not available for 8GB model.

4.4 Mean Time Between Failures (MTBF)

Mean Time Between Failures (MTBF) is predicted based on reliability data for the individual components in CFast. Serving as statistical reference, the prediction result for CFast is more than 2,000,000 hours.

Notes about MTBF:

The prediction is based on Bellcore analysis method by assuming device failure rate can be generated by the sum of failure rates in each component.

4.5 Certification and Compliance

CFast complies with the following standards

- CE
- FCC
- RoHS
- MIL-STD

5. Flash Management

5.1 Error Correction/Detection

CFast implements a hardware ECC which is based on the BCH algorithm. It can detect and correct up to 16 bits or 24 bits error in 1K bytes depending on the NAND flash configuration used.

5.2 Bad Block Management

Current production technology is unable to guarantee total reliability of NAND flash memory array. When a flash memory device leaves factory, it comes with a minimal number of initial bad blocks during production or out-of-factory as there is no currently known technology that produce flash chips free of bad blocks. In addition, bad blocks may develop during program/erase cycles. When host performs program/erase command on a block, bad block may appear in Status Register. Since bad blocks are inevitable, the solution is to keep them in control. Apacer flash devices are programmed with ECC, block mapping technique and S.M.A.R.T to reduce invalidity or error. Once bad blocks are detected, data in those blocks will be transferred to free blocks and error will be corrected by designated algorithms.

5.3 Wear Leveling

Flash memory devices differ from Hard Disk Drives (HDDs) in terms of how blocks are utilized. For HDDs, when a change is made to stored data, like erase or update, the controller mechanism on HDDs will perform overwrites on blocks. Unlike HDDs, flash blocks cannot be overwritten and each P/E cycle wears down the lifespan of blocks gradually. Repeatedly program/erase cycles performed on the same memory cells will eventually cause some blocks to age faster than others. This would bring flash storages to their end of service term sooner. Wear leveling is an important mechanism that level out the wearing of blocks so that the wearing-down of blocks can be almost evenly distributed. This will increase the lifespan of SSDs. Commonly used wear leveling types are Static and Dynamic.

5.4 Power Failure Management

Power Failure Management plays a crucial role when experiencing unstable power supply. Power disruption may occur when users are storing data into the SSD. In this urgent situation, the controller would run multiple write-to-flash cycles to store the metadata for later block rebuilding. This urgent operation requires about several milliseconds to get it done. At the next power up, the firmware will perform a status tracking to retrieve the mapping table and resume previously programmed NAND blocks to check if there is any incompleteness of transmission.

5.5 ATA Secure Erase

ATA Secure Erase is an ATA disk purging command currently embedded in most of the storage drives. Defined in ATA specifications, (ATA) Secure Erase is part of Security Feature Set that allows storage drives to erase all user data areas. The erase process usually runs on the firmware level as most of the ATA-based storage media currently in the market are built-in with this command. ATA Secure Erase can securely wipe out the user data in the drive and protects it from malicious attack.

5.6 S.M.A.R.T.

S.M.A.R.T. is an abbreviation for Self-Monitoring, Analysis and Reporting Technology, a self-monitoring system that provides indicators of drive health as well as potential disk problems. It serves as a warning for users from unscheduled downtime by monitoring and displaying critical drive information. Ideally, this should allow taking proactive actions to prevent drive failure and make use of S.M.A.R.T. information for future product development reference.

Apacer devices use the standard SMART command B0h to read data out from the drive to activate our S.M.A.R.T. feature that complies with the ATA/ATAPI specifications. S.M.A.R.T. Attribute IDs shall include initial bad block count, total later bad block count, maximum erase count, average erase count, power on hours and power cycle. When the S.M.A.R.T. Utility running on the host, it analyzes and reports the disk status to the host before the device reaches in critical condition.

Note: attribute IDs may vary from product models due to various solution design and supporting capabilities.

5.7 TRIM

TRIM, though in capital letters usually, is a memory computation command rather than an abbreviation. It is mainly a SATA command that enables the operating system to inform the SSD (Solid State Drive) which blocks of previously stored data are no longer valid, due to erases by the host or operating system, such as file deletions or disk formatting. Once notified, SSD will begin the discard of the invalid LBAs and retain more space for itself, in fact, the discarded is no longer recoverable.

When an LBA is replaced by the operating system, as with overwrite of a file, the SSD is informed that the originally occupied LBA is determined as no longer in use or invalid. The SSD will not save those blocks in garbage collected sectors. Noticeably, a file deletion command by host or operating system never actually erases the actual content, rather, just the file is marked as deleted. This issue is even specifically noticeable for flash based memory devices, such as SSDs. In fact, an SSD will keep garbage collecting the invalid, previously occupied LBAs, if it is not informed that these LBAs can be erased. Thus, the SSD would experience a significant performance downfall.

6. Software Interface

6.1 ATA Command Set

Table 6-1 summarizes the ATA command set with the paragraphs that follow describing the individual commands and the task file for each.

Table 6-1: Command set

Code	Command	Code	Command
E5h	Check Power Mode	F3h	Security Erase Prepare
06h	Data Set Management	F4h	Security Erase Unit
90h	Execute Device Diagnostic	F5h	Security Freeze Lock
E7h	Flush Cache	F1h	Security Set Password
Eah	Flush Cache EXT	F2h	Security Unlock
Ech	Identify Device	70h	Seek
E3h	Idle	Efh	Set Features
E1h	Idle Immediate	C6h	Set Multiple Mode
91h	Initialize Device Parameters	E6h	Sleep
C8h	Read DMA	B0h	SMART
25h	Read DMA EXT	E2h	Standby
C4h	Read Multiple	E0h	Standby Immediate
29h	Read Multiple EXT	Cah	Write DMA
20h	Read Sector	35h	Write DMA EXT
24h	Read Sector EXT	C5h	Write Multiple
40h	Read Verify Sectors	39h	Write Multiple EXT
42h	Read Verify Sectors EXT	30h	Write Sector
10h	Recalibrate	34h	Write Sector EXT
F6h	Security Disable Password		

7. Electrical Specification

7.1 Operating Voltage

Table 7-1 lists operating voltage of CFast.

Table 7-1: Operating voltage

Parameter	Symbol	Min	Typ	Max	Units
Power Supply	Vcc	3.135	3.3	3.465	V

7.2 Power Consumption

Table 7-3 Power consumption (typical)

Mode \ Capacity	8 GB	16 GB	32 GB	64 GB	128 GB
Active (mA)	225	225	235	305	315
Standby (mA)	85	85	85	85	85

Note: Power consumption may vary from flash configurations and/or platform settings.

8. Physical Characteristics

8.1 Dimensions

TABLE 8-1: CFast physical specification

Length:	36.40 ±0.15 mm
Width:	42.80 ±0.10 mm
Thickness (Including Label Area):	3.6 mm (Max)

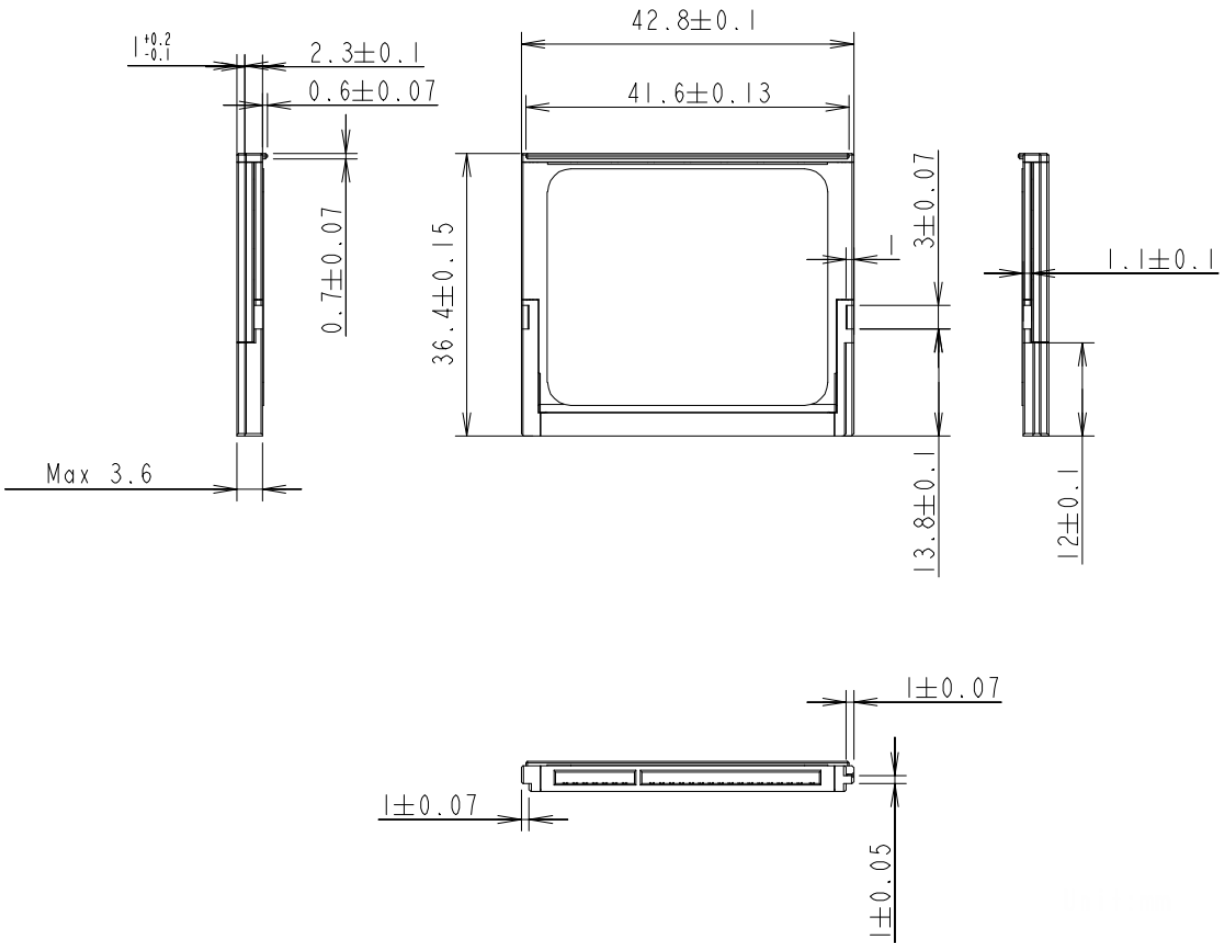

Unit: mm

FIGURE 8-1: Physical dimension

9. Product Ordering Information

9.1 Product Code Designations

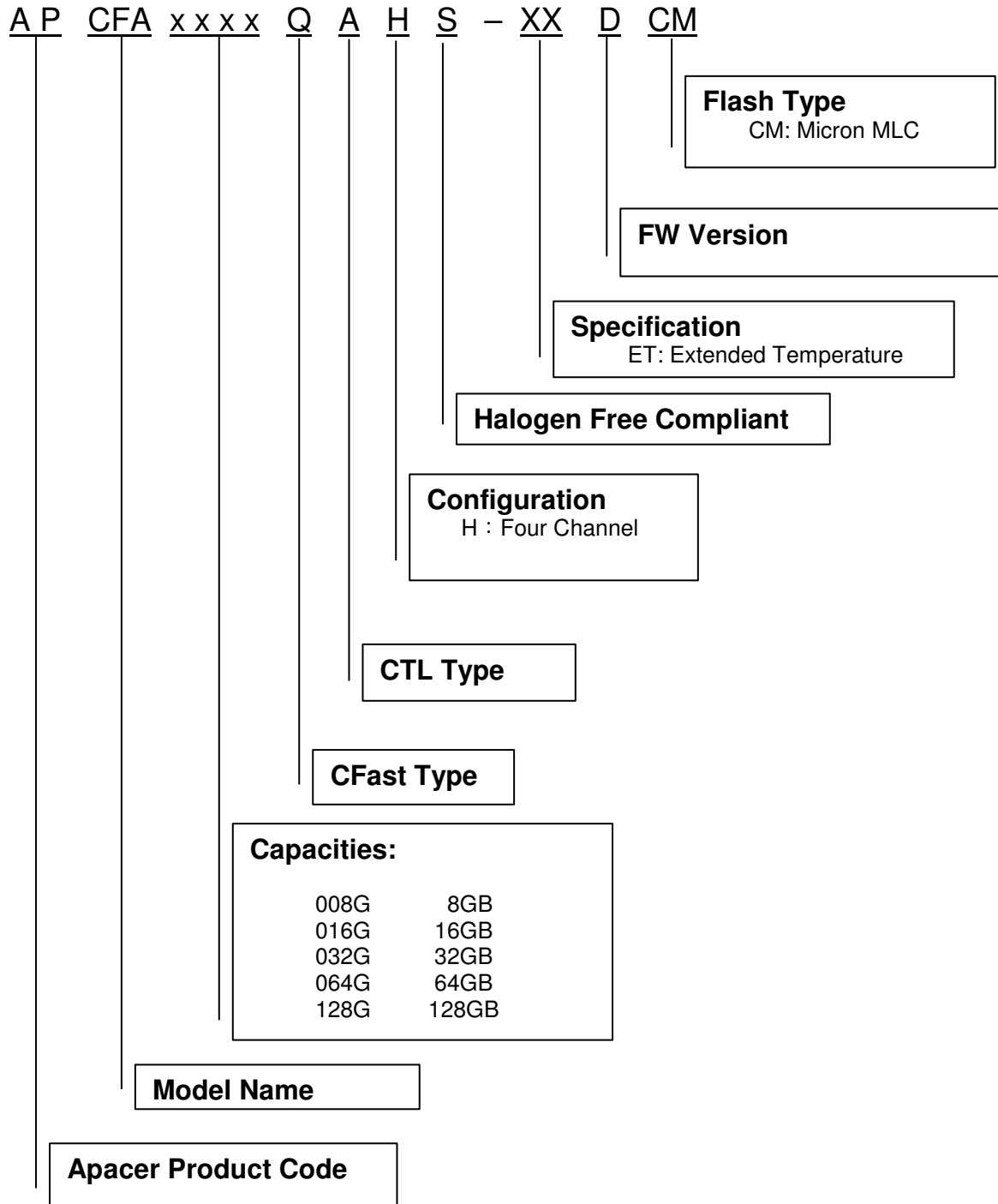

9.2 Valid Combinations

Capacity	AP/N	AP/N—Extended Temp.
8GB	APCFA008GQAHS-DCM	N/A
16GB	APCFA016GQAHS-DCM	APCFA016GQAHS-ETDCM
32GB	APCFA032GQAHS-DCM	APCFA032GQAHS-ETDCM
64GB	APCFA064GQAHS-DCM	APCFA064GQAHS-ETDCM
128GB	APCFA128GQAHS-DCM	APCFA128GQAHS-ETDCM

Note:

- Valid combinations list out the available models for mass production.
- Products are normally shipped in unformatted capacities unless required otherwise.
- For customization request, please consult with Apacer sales representatives.

Revision History

Revision	Date	Description	Remark
1.0	07/31/2012	Official release	
1.1	08/21/2012	Updated the address of Indian branch Updated Product Ordering Information (removed the wordings of "for Windows & Linux")	
1.2	06/25/2013	Updated Product Ordering Information due to firmware upgrade	

Global Presence

Taiwan (Headquarters)	Apacer Technology Inc. 4 th Fl, 75 Hsin Tai Wu Rd., Sec.1 Hsichih, New Taipei City Taiwan 221 R.O.C. Tel: +886-2-2698-2888 Fax: +886-2-2698-2889 amtsales@apacer.com
U.S.A.	Apacer Memory America, Inc. 386 Fairview Way, Suite102, Milpitas, CA 95035 Tel: 1-408-518-8699 Fax: 1-408-935-9611 sa@apacerus.com
Japan	Apacer Technology Corp. 5F, Matsura Bldg., Shiba, Minato-Ku Tokyo, 105-0014, Japan Tel: 81-3-5419-2668 Fax: 81-3-5419-0018 jpservices@apacer.com
Europe	Apacer Technology B.V. Science Park Eindhoven 5051 5692 EB Son, The Netherlands Tel: 31-40-267-0000 Fax: 31-40-267-0000#6199 sales@apacer.nl
China	Apacer Electronic (Shanghai) Co., Ltd 1301, No.251,Xiaomujiao Road, Shanghai, 200032, China Tel: 86-21-5529-0222 Fax: 86-21-5206-6939 sales@apacer.com.cn
India	Apacer Technologies Pvt Ltd, # 535, 1st Floor, 8th cross, JP Nagar 3rd Phase, Bangalore – 560078, India Tel: 91-80-4152-9061 sales_india@apacer.com