

**RoHS Compliant**

**CFast 2.0**

SM22P-CFast 2.0 Product Specifications  
CorePower Series

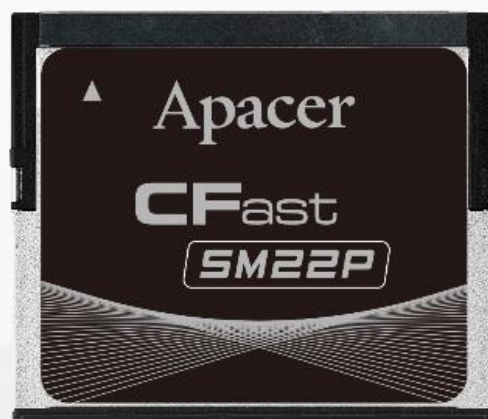

**March 19, 2020**

**Version 1.5**



**Apacer Technology Inc.**

1F, No.32, Zhongcheng Rd., Tucheng Dist., New Taipei City, Taiwan, R.O.C

Tel: +886-2-2267-8000 Fax: +886-2-2267-2261

[www.apacer.com](http://www.apacer.com)

## Specifications Overview:

- **Standard Serial ATA Interface**
  - SATA Revision 3.1 compliance
  - SATA 6 Gb/s interface speed
  - Backward compatible with SATA 1.5 and 3 Gb/s interfaces
  - ATA-compatible command set
- **Capacity**
  - 8, 16, 32, 64, 128 GB
- **Performance\***
  - Sequential read: Up to 475 MB/sec
  - Sequential write: Up to 85 MB/sec
  - Random read (4K): Up to 76,000 IOPS
  - Random write (4K): Up to 16,000 IOPS
- **Flash Management**
  - Built-in hardware ECC
  - Global Wear Leveling
  - Flash bad-block management
  - Flash Translation Layer: Page Mapping
  - S.M.A.R.T.
  - Power Failure Management
  - Device Sleep (optional)
  - ATA Secure Erase
  - TRIM
- **DRAM Cache for Enhanced Random Performance**
- **NAND Flash Type: MLC**
- **MTBF: >1,000,000 hours**
- **Temperature Range**
  - Operating:
    - Standard: 0°C to 70°C
    - Wide: -40°C to 85°C
  - Storage: -40°C to 100°C
- **Power Consumption\***
  - Supply voltage: 3.3V
  - Active mode: 610 mA
  - Idle mode: 140 mA
- **Connector Type**
  - 7 + 17 pin female connector
- **Shock & Vibration\*\***
  - Shock: 1,500 G
  - Vibration: 15 G
- **Apacer CorePower** – implementation of Tantalum Capacitors to serve as backup power supply, capable of withstanding extended ambient temperature
- **RoHS Compliant**

\*Varies from capacities. The values for performances and power consumptions presented are typical and may vary depending on flash configurations or platform settings.

\*\*Non-operating

## Table of Contents

<b>1. General Descriptions .....</b>	<b>3</b>
<b>2. Functional Block .....</b>	<b>3</b>
<b>3. Pin Assignments.....</b>	<b>4</b>
<b>4. Product Specifications.....</b>	<b>6</b>
4.1 Capacity.....	6
4.2 Performance .....	6
4.3 Environmental Specifications .....	7
4.4 Mean Time Between Failures (MTBF) .....	7
4.5 Certification and Compliance.....	7
<b>5. Flash Management .....</b>	<b>8</b>
5.1 Error Correction/Detection.....	8
5.2 Bad Block Management .....	8
5.3 Global Wear Leveling .....	8
5.4 Flash Translation Layer – Page Mapping.....	8
5.5 ATA Secure Erase.....	8
5.6 Power Failure Management .....	9
5.7 TRIM.....	9
5.8 SATA Power Management.....	9
5.9 DEVSLP (DevSleep or DEVSLP) Mode (optional).....	10
<b>6. Software Interface .....</b>	<b>11</b>
6.1 Command Set.....	11
6.2 S.M.A.R.T. ....	11
<b>7. Electrical Specifications.....</b>	<b>13</b>
7.1 Operating Voltage.....	13
7.2 Power Consumption .....	13
7.3 Apacer CorePower .....	14
<b>8. Physical Characteristics.....</b>	<b>15</b>
<b>9. Product Ordering Information.....</b>	<b>16</b>
9.1 Product Code Designations.....	16
9.2 Valid Combinations.....	17

## 1. General Descriptions

Featuring CorePower technology, Apacer SM22P-CFast has been proved capable of protecting data from sudden power loss after conducting comprehensive testing. With firmware routines and the design of intelligent hardware architecture, SM22P-CFast ensures that all data can be stored on the NAND flash in the event of power outage. CFast™ is a crossover between the CompactFlash™ (CF) card form factor and the Serial ATA (SATA) interface. Therefore, it can replace both roles of HDDs and CompactFlash™ cards in applications requiring small form factors and harsh environmental conditions. By implementing a backup power supply that lengthens the emergent hold-on time for the controller to move all the cached data into NAND flash, the internal controlling unit of the SM22P-CFast 2.0 is engineered with DRAM for enhanced random performance without any concern over data integrity.

## 2. Functional Block

Apacer SM22P-CFast 2.0 includes a single-chip SATA 6 Gb/s and the flash media. The controller integrates the flash management unit to support multi-channel, multi-bank flash arrays. Figure 2-1 shows the functional block diagram.

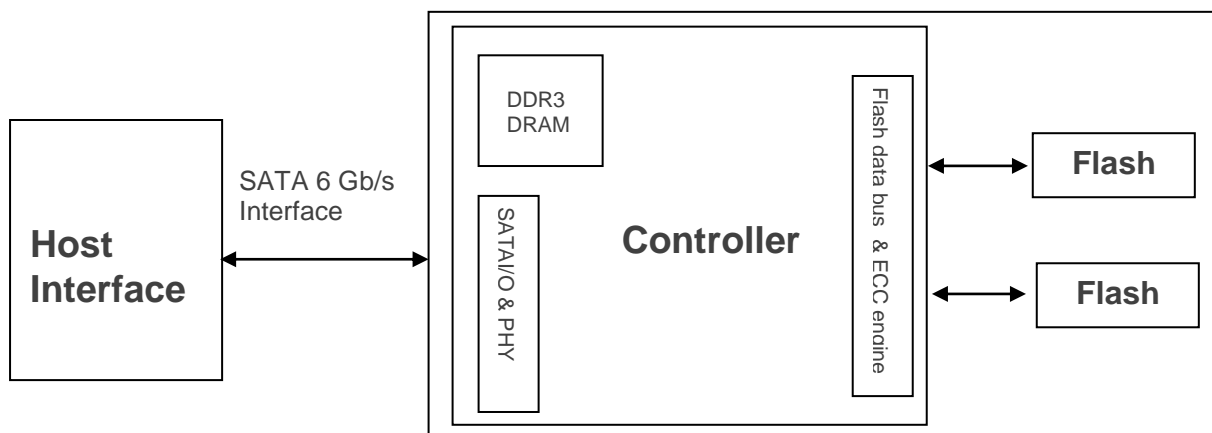

Figure 2-1 Functional Block Diagram

### 3. Pin Assignments

Table 3-1 describes SM22P-CFast 2.0 signal segment, and Table 3-2, its power segment.



**Figure 3-1** Pin Assignment

**Table 3-1** Signal Segment

Pin	Definition	Description
S1	GND	Ground
S2	A+	SATA Differential Signal Pair A
S3	A-	
S4	GND	Ground
S5	B-	SATA Differential Signal Pair B
S6	B+	
S7	GND	Ground

Table 3-2 Power Segment

Pin	Definition	Type	Description
PC1	CDI	Input	Card Detect In
PC2	PGND	Device GND	Device GND
PC3	DEVSLP*	DEVSLP card input	DEVSLP enable
PC4			Reserved
PC5			Reserved
PC6			Reserved
PC7	PGND	Device GND	Device GND
PC8	LED1	LED Output	Power indicator
PC9	LED2	LED Output	Access indicator
PC10			Reserved
PC11			Write Protect**
PC12	IFDet	GND	Card output, connect to PGND on card
PC13	PWR	3.3V	Device power (3.3V)
PC14	PWR	3.3V	Device power (3.3V)
PC15	PGND	Device GND	Device GND
PC16	PGND	Device GND	Device GND
PC17	CDO	Output	Card Detect Out

\*Optional

\*\*Enabled by adjusting the pin "PC11" from high to low active

Notes about Write Protect:

Apacer implements the Virtual Write scheme that allows write commands to go through the flash controller and data is temporarily stored, but no data has been actually written into the flash. Once the host resets or restarts the system, all the temporarily stored data will disappear and nowhere to be found in the drive. Since the Virtual Write scheme runs at device level, it requires no software or driver installation and is independent from the host OS.

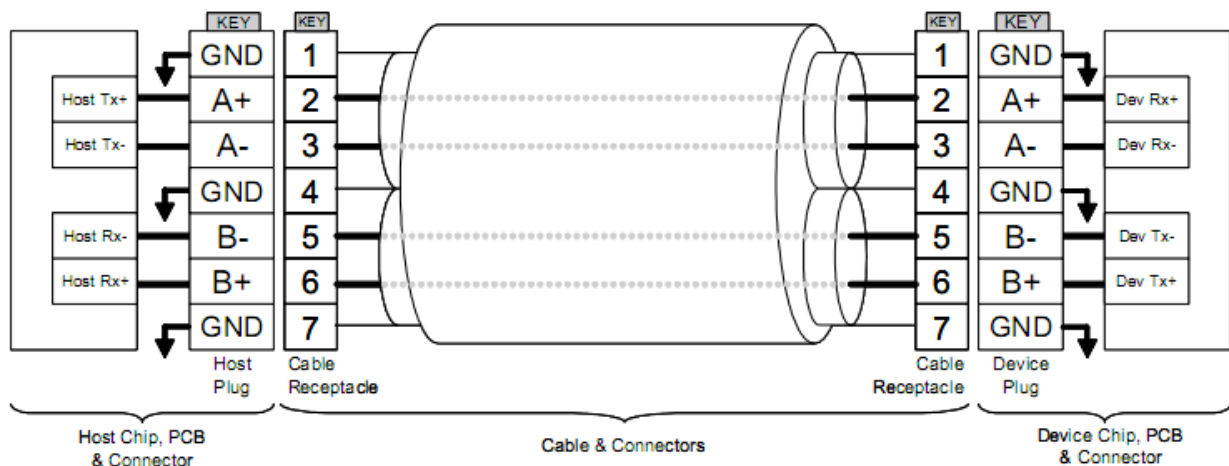

Figure 3-2 SATA Cable / Connector Connection Diagram

The connector on the left represents the Host with TX/RX differential pairs connected to a cable while the connector on the right shows the Device with TX/RX differential pairs also connected to the cable. Notice also the ground path connecting the shielding of the cable to the Cable Receptacle.

## 4. Product Specifications

### 4.1 Capacity

Capacity specifications of SM22P-CFast 2.0 are available as shown in Table 4-1. It lists the specific capacity and the default numbers of heads, sectors and cylinders for each product line.

**Table 4-1** Capacity Specifications

Capacity	Total bytes*	Cylinders	Heads	Sectors	Max LBA
8 GB	8,012,390,400	15,525	16	63	15,649,200
16 GB	16,013,942,784	16,383	16	63	31,277,232
32 GB	32,017,047,552	16,383	16	63	62,533,296
64 GB	64,023,257,088	16,383	16	63	125,045,424
128 GB	128,035,676,160	16,383	16	63	250,069,680

\*Display of total bytes varies from file systems, which means not all of the bytes can be used for storage.

\*\*Notes: 1 GB = 1,000,000,000 bytes; 1 sector = 512 bytes.

LBA count addressed in the table above indicates total user storage capacity and will remain the same throughout the lifespan of the device. However, the total usable capacity of the SSD is most likely to be less than the total physical capacity because a small portion of the capacity is reserved for device maintenance usages.

### 4.2 Performance

Performance of SM22P-CFast 2.0 is listed below in Table 4-2.

**Table 4-2** Performance Specifications

Performance	Capacity	8 GB	16 GB	32 GB	64 GB	128 GB
	<b>Sequential Read* (MB/s)</b>		120	215	400	390
<b>Sequential Write* (MB/s)</b>		13	48	85	75	75
<b>Random Read IOPS** (4K)</b>		16,000	26,000	48,000	45,000	76,000
<b>Random Write IOPS** (4K)</b>		3,000	7,000	13,000	12,000	16,000

Note:

Results may differ from various flash configurations or host system setting.

\*Sequential performance is based on CrystalDiskMark 5.2.1 with file size 1,000MB.

\*\*Random performance measured using IOMeter with Queue Depth 32.

### 4.3 Environmental Specifications

Environmental specifications of SM22P-CFast 2.0 product are shown in Table 4-3.

**Table 4-3** Environmental Specifications

Item	Specifications
Operating temp.	0°C to 70°C (Standard); -40°C to 85°C (Wide)
Non-operating temp.	-40°C to 100°C
Operating vibration	7.69 GRMS, 20~2000 Hz/random (compliant with MIL-STD-810G)
Non-operating vibration	4.02 GRMS, 15~2000 Hz/random (compliant with MIL-STD-810G)
Operating shock	50G, 11ms
Non-operating shock	1500G, 0.5ms (compliant with MIL-STD-883K)

Note: This Environmental Specification table indicates the conditions for testing the device. Real world usages may affect the results.

### 4.4 Mean Time Between Failures (MTBF)

Mean Time Between Failures (MTBF) is predicted based on reliability data for the individual components in SM22P-CFast 2.0. The prediction result for SM22P-CFast 2.0 is more than 1,000,000 hours.

Note: The MTBF is predicated and calculated based on “Telcordia Technologies Special Report, SR-332, Issue 2” method.

### 4.5 Certification and Compliance

SM22P-CFast 2.0 complies with the following standards:

- CE
- FCC
- RoHS
- MIL-STD-810G

## 5. Flash Management

### 5.1 Error Correction/Detection

Apacer implements a hardware ECC scheme, based on the BCH algorithm. It can detect and correct up to 72 bits error in 1K bytes.

### 5.2 Bad Block Management

Current production technology is unable to guarantee total reliability of NAND flash memory array. When a flash memory device leaves factory, it comes with a minimal number of initial bad blocks during production or out-of-factory as there is no currently known technology that produce flash chips free of bad blocks. In addition, bad blocks may develop during program/erase cycles. When host performs program/erase command on a block, bad block may appear in Status Register. Since bad blocks are inevitable, the solution is to keep them in control. Apacer flash devices are programmed with ECC, page mapping technique and S.M.A.R.T to reduce invalidity or error. Once bad blocks are detected, data in those blocks will be transferred to free blocks and error will be corrected by designated algorithms.

### 5.3 Global Wear Leveling

Flash memory devices differ from Hard Disk Drives (HDDs) in terms of how blocks are utilized. For HDDs, when a change is made to stored data, like erase or update, the controller mechanism on HDDs will perform overwrites on blocks. Unlike HDDs, flash blocks cannot be overwritten and each P/E cycle wears down the lifespan of blocks gradually. Repeatedly program/erase cycles performed on the same memory cells will eventually cause some blocks to age faster than others. This would bring flash storages to their end of service term sooner. Global wear leveling is an important mechanism that levels out the wearing of all blocks so that the wearing-down of all blocks can be almost evenly distributed. This will increase the lifespan of SSDs.

### 5.4 Flash Translation Layer – Page Mapping

Page mapping is an advanced flash management technology whose essence lies in the ability to gather data, distribute the data into flash pages automatically, and then schedule the data to be evenly written. Page-level mapping uses one page as the unit of mapping. The most important characteristic is that each logical page can be mapped to any physical page on the flash memory device. This mapping algorithm allows different sizes of data to be written to a block as if the data is written to a data pool and it does not need to take extra operations to process a write command. Thus, page mapping is adopted to increase random access speed and improve SSD lifespan, reduce block erase frequency, and achieve optimized performance and lifespan.

### 5.5 ATA Secure Erase

ATA Secure Erase is an ATA disk purging command currently embedded in most of the storage drives. Defined in ATA specifications, (ATA) Secure Erase is part of Security Feature Set that allows storage drives to erase all user data areas. The erase process usually runs on the firmware level as most of the ATA-based storage media currently in the market are built-in with this command. ATA Secure Erase can securely wipe out the user data in the drive and protects it from malicious attack.

## 5.6 Power Failure Management

Power Failure Management plays a crucial role when experiencing unstable power supply. Power disruption may occur when users are storing data into the SSD. In this urgent situation, the controller would run multiple write-to-flash cycles to store the metadata for later block rebuilding. This urgent operation requires about several milliseconds to get it done. At the next power up, the firmware will perform a status tracking to retrieve the mapping table and resume previously programmed NAND blocks to check if there is any incompleteness of transmission.

Note: The controller unit of this product model is designed with a DRAM as a write cache for improved performance and data efficiency. Though unlikely to happen in most cases, the data cached in the volatile DRAM might be potentially affected if a sudden power loss takes place before the cached data is flushed into non-volatile NAND flash memory.

## 5.7 TRIM

TRIM is a SATA command that helps improve the read/write performance and efficiency of solid-state drives (SSD). The command enables the host operating system to inform SSD controller which blocks contain invalid data, mostly because of the erase commands from host. The invalid will be discarded permanently and the SSD will retain more space for itself.

## 5.8 SATA Power Management

By complying with SATA 6 Gb/s specifications, the SSD supports the following SATA power saving modes:

- ACTIVE: PHY ready, full power, Tx & Rx operational
- PARTIAL: Reduces power, resumes in under 10  $\mu$ s (microseconds)
- SLUMBER: Reduces power, resumes in under 10 ms (milliseconds)
- HIPM: Host-Initiated Power Management
- DIPM: Device-Initiated Power Management
- AUTO-SLUMBER: Automatic transition from partial to slumber.
- Device Sleep (DevSleep or DEVSLP): PHY powered down; power consumption  $\leq$  5 mW; host assertion time  $\leq$  10 ms; exit timeout from this state  $\leq$  20 ms (unless specified otherwise in SATA Identify Device Log).

Note:

1. The behaviors of power management features would depend on host/device settings.
2. Device Sleep mode is optional depending on product ordering selections.

### 5.9 DEVSLP (DevSleep or DEVSLP) Mode (optional)

Device Sleep is a feature that allows SATA devices to enter a low power mode by designating a particular pin as DEVSLP signal with an aim to reducing power consumption.

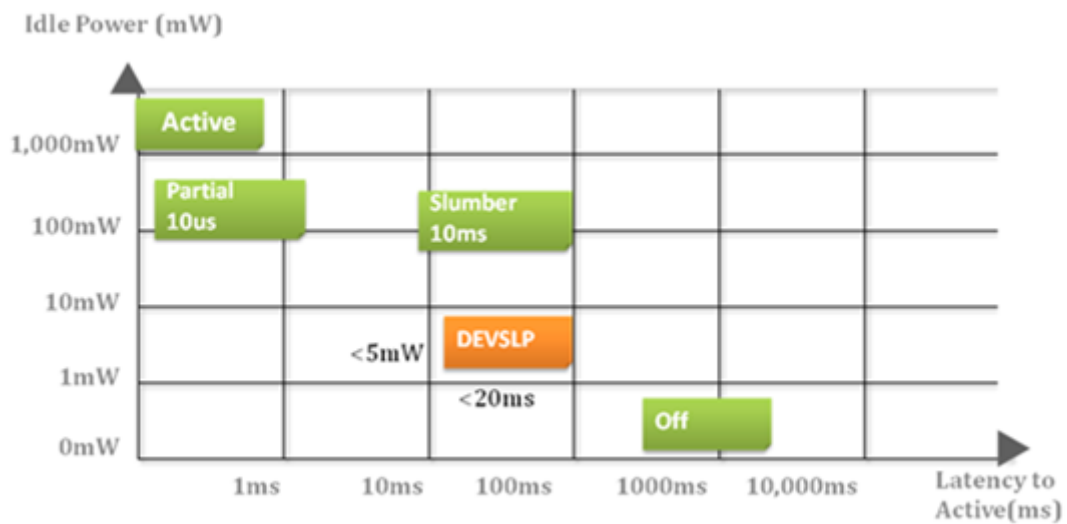

## 6. Software Interface

### 6.1 Command Set

Table 6-1 Command Set

Code	Command	Code	Command
E5h	CHECK POWER MODE	F6h	SECURITY DISABLE PASSWORD
90h	EXECUTE DIAGNOSTICS	F3h	SECURITY ERASE PREPARE
E7h	FLUSH CACHE	F4h	SECURITY ERASE UNIT
ECh	IDENTIFY DEVICE	F5h	SECURITY FREEZE LOCK
E3h	IDLE	F1h	SECURITY SET PASSWORD
E1h	IDLE IMMEDIATE	F2h	SECURITY UNLOCK
91h	INITIALIZE DEVICE PARAMETERS	7Xh	SEEK
C8h	READ DMA	EFh	SET FEATURES
25h	READ DMA EXT	C6h	SET MULTIPLE MODE
60h	READ FPDMA QUEUED	E6h	SLEEP
47h	READ LOG DMA EXT	B0h	S.M.A.R.T.
2Fh	READ LOG EXT	E2h	STANDBY
C4h	READ MULTIPLE	E0h	STANDBY IMMEDIATE
20 or 21h	READ SECTOR(S)	CAh	WRITE DMA
40 or 41h	READ VERIFY SECTOR(S)	35h	WRITE DMA EXT
10h	RECALIBRATE	61h	WRITE FPDMA QUEUED
57h	WRITE LOG DMA EXT	3Fh	WRITE LOG EXT
C5h	WRITE MULTIPLE	30h or 31h	WRITE SECTOR(S)

### 6.2 S.M.A.R.T.

S.M.A.R.T. is an abbreviation for Self-Monitoring, Analysis and Reporting Technology, a self-monitoring system that provides indicators of drive health as well as potential disk problems. It serves as a warning for users from unscheduled downtime by monitoring and displaying critical drive information. Ideally, this should allow taking proactive actions to prevent drive failure and make use of S.M.A.R.T. information for future product development reference.

Apacer devices use the standard SMART command B0h to read data out from the drive to activate our S.M.A.R.T. feature that complies with the ATA/ATAPI specifications. S.M.A.R.T. Attribute IDs shall include initial bad block count, total later bad block count, maximum erase count, average erase count, power on hours and power cycle. When the S.M.A.R.T. Utility running on the host, it analyzes and reports the disk status to the host before the device reaches in critical condition.

Note: Attribute IDs may vary from product models due to various solution design and supporting capabilities.

Apacer memory products come with S.M.A.R.T. commands and subcommands for users to obtain information of drive status and to predict potential drive failures. Users can take advantage of the following commands/subcommands to monitor the health of the drive.

Code	SMART Subcommand
D0h	READ DATA
D1h	READ ATTRIBUTE THRESHOLDS
D2h	ENABLE/DISABLE ATTRIBUTE AUTOSAVE
D4h	EXECUTE OFF-LINE IMMEDIATE
D5h	SMART READ LOG
D6h	SMART WRITE LOG
D8h	ENABLE OPERATIONS
D9h	DISABLE OPERATIONS
DAh	RETURN STATUS

### General SMART attribute structure

Byte	Description
0	ID (Hex)
1 – 2	Status Flag
3	Value
4	Worst
5*-11	Raw Data

\*Byte 5: LSB

### SMART attribute ID list

ID (Hex)	Attribute Name
9 (0x09)	Power-on Hours
12 (0x0C)	Power Cycle Count
163 (0xA3)	Max. Erase Count
164 (0xA4)	Avg. Erase Count
166 (0xA6)	Total Later Bad Block Count
167 (0xA7)	SSD Protect Mode (Vendor Specific)
168 (0xA8)	SATA PHY Error Count
171 (0xAB)	Program Fail Count
172 (0xAC)	Erase Fail Count
175 (0xAF)	Bad Cluster Table Count
192 (0xC0)	Unexpected Power Loss Count
194 (0xC2)	Temperature
231 (0xE7)	Lifetime Left
241 (0xF1)	Total Sectors of Write

## 7. Electrical Specifications

### 7.1 Operating Voltage

Table 7-1 lists the supply voltage for SM22P-CFast 2.0.

**Table 7-1** Operating Range

Parameter	Symbol	Min	Type	Max	Units
Power Supply	Vcc	3.135	3.3	3.465	V

### 7.2 Power Consumption

Table 7-2 lists the power consumption for SM22P-CFast 2.0.

**Table 7-2** Power Consumption

Capacity Mode	8 GB	16 GB	32 GB	64 GB	128 GB
<b>Active (mA)</b>	265	335	405	410	610
<b>Idle (mA)</b>	130	140	115	120	120

Note:

\*All values are typical and may vary depending on flash configurations or host system settings.

\*\*Active power is an average power measurement performed using CrystalDiskMark with 128KB sequential read/write transfers.

### 7.3 Apacer CorePower

If the voltage supply is cut, for instance, accidental power off or sudden blackout, the data would be shortly lost. To protect SSD data integrity from this disastrous scenario, Apacer has developed the hardware-based technology named Apacer CorePower. The CorePower equips SSDs with electrolytic capacitors that can deliver urgent power current so that the flash controller can take this extended moment to flush cached data and essential metadata into NAND Flash blocks.

In addition to electrolytic capacitors which guarantee SSD data integrity, an inbuilt IC detector also serves the same purpose as well as ensures the stability of data transmission. The detector is designed to take proactive measures for the aforementioned disastrous scenario. When supply voltage drops below a minimum threshold, the detector will send out signals to the flash controller notifying it to stop operating to prevent poor performance or erratic operation. In the meanwhile, signals will also be sent to DRAM to have cached data flushed into NAND Flash blocks so as to avoid data loss, similar to the function performed by electrolytic capacitors.

SM22P-CFast is equipped with Tantalum Capacitors which have lower power leakage, higher operating temperature and higher volume-efficiency (high capacitance in small volume) than many other types of capacitors. The compact size and the high reliability are ideal for embedded computing systems.

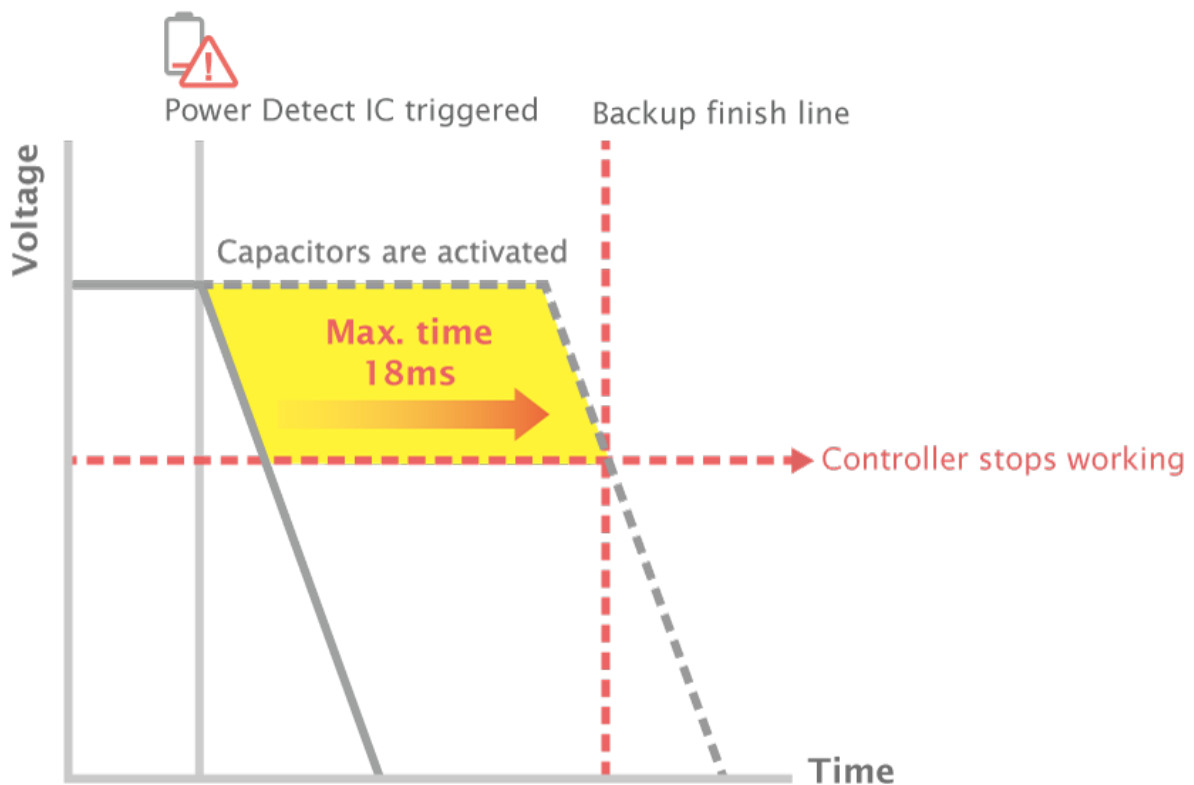
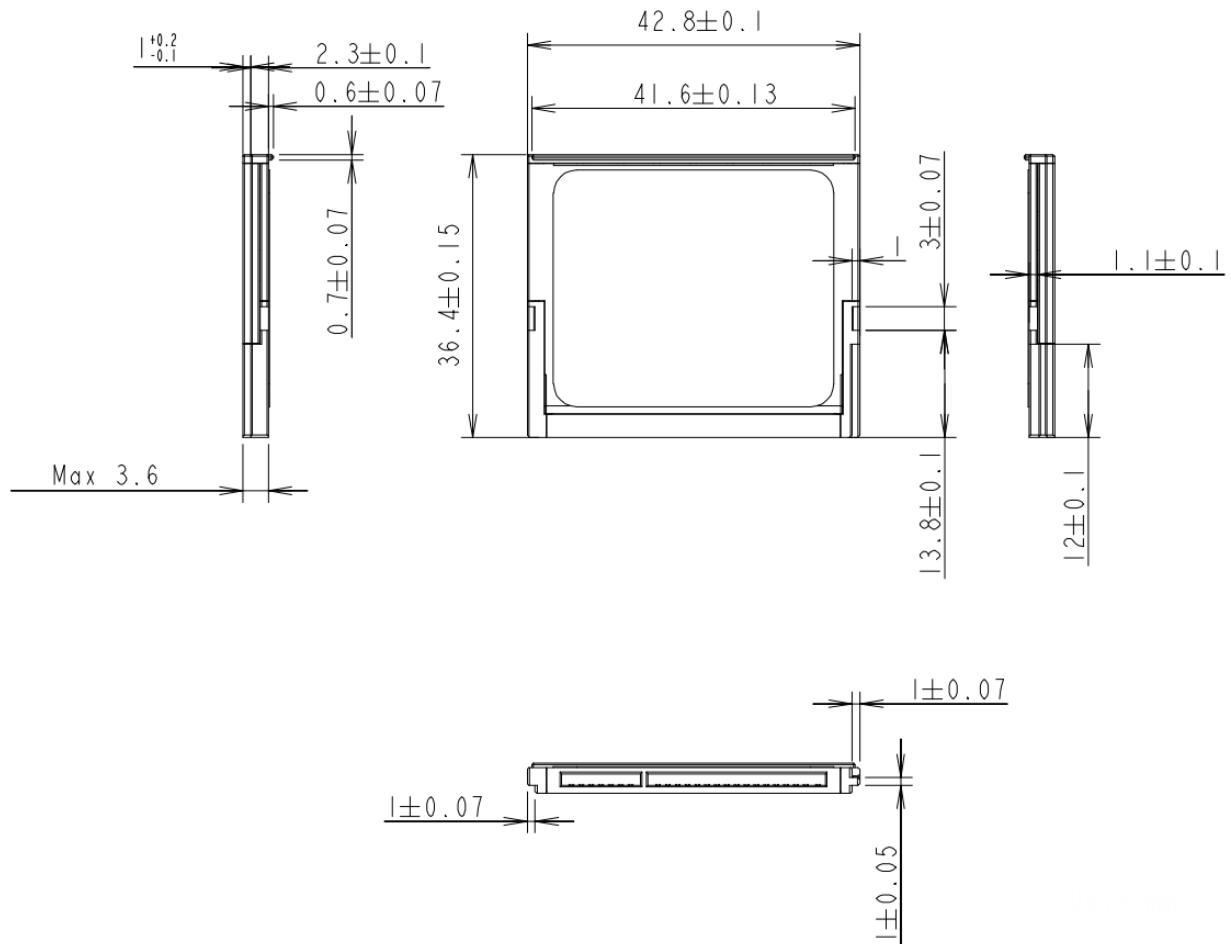

Figure 7-1 3.3V CorePower Technology Illustration

## 8. Physical Characteristics



Unit: mm

Figure 8-1 Physical Dimensions

## 9. Product Ordering Information

### 9.1 Product Code Designations

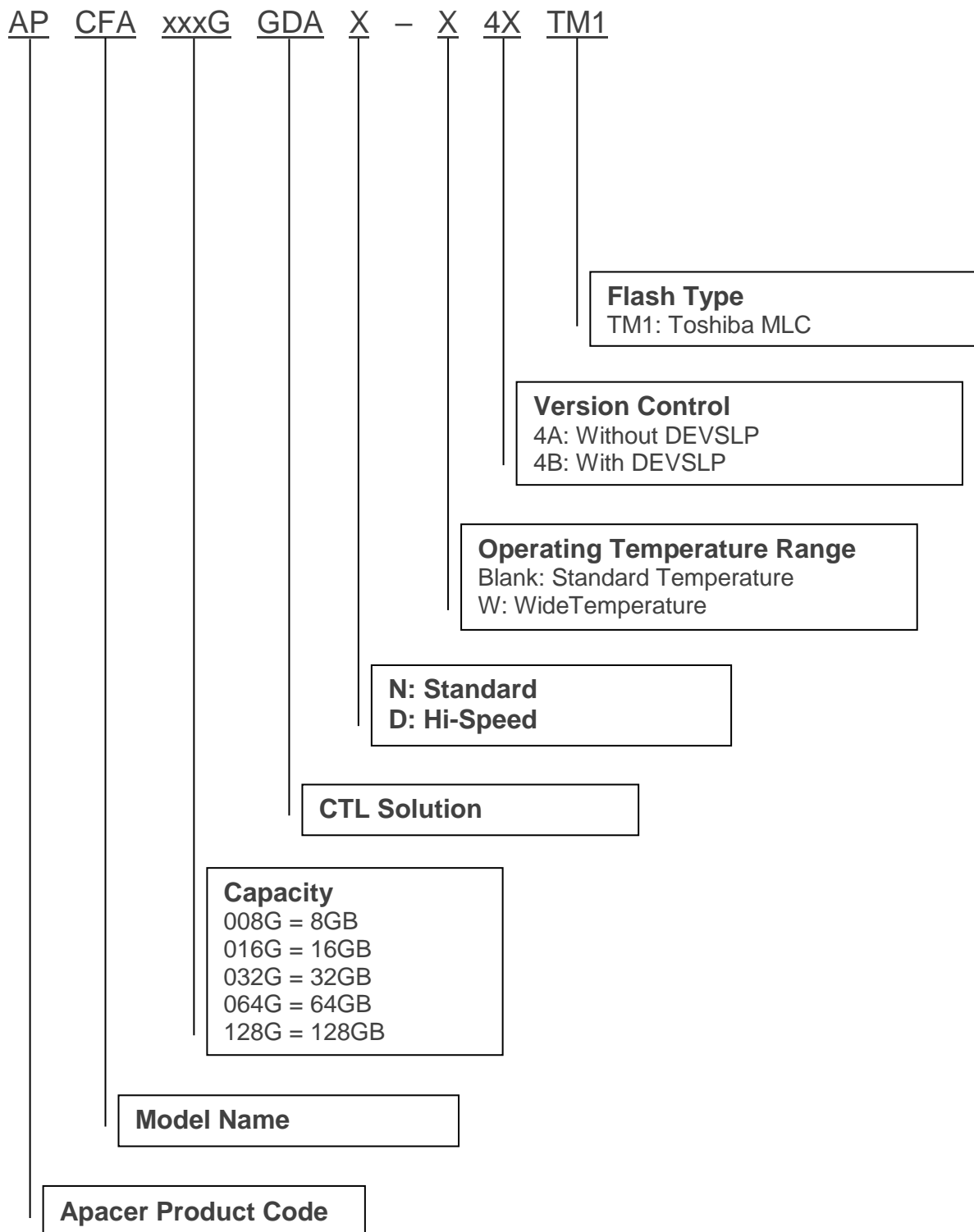

## 9.2 Valid Combinations

### 9.2.1 Standard Temperature (0°C to 70°C)

Capacity	Without DEVSLP	With DEVSLP
8GB	APCFA008GGDAN-4ATM1	APCFA008GGDAN-4BTM1
16GB	APCFA016GGDAN-4ATM1	APCFA016GGDAN-4BTM1
32GB	APCFA032GGDAD-4ATM1	APCFA032GGDAD-4BTM1
64GB	APCFA064GGDAD-4ATM1	APCFA064GGDAD-4BTM1
128GB	APCFA128GGDAD-4ATM1	APCFA128GGDAD-4BTM1

### 9.2.2 Wide Temperature (-40°C to 85°C)

Capacity	Without DEVSLP	With DEVSLP
8GB	APCFA008GGDAN-W4ATM1	APCFA008GGDAN-W4BTM1
16GB	APCFA016GGDAN-W4ATM1	APCFA016GGDAN-W4BTM1
32GB	APCFA032GGDAD-W4ATM1	APCFA032GGDAD-W4BTM1
64GB	APCFA064GGDAD-W4ATM1	APCFA064GGDAD-W4BTM1
128GB	APCFA128GGDAD-W4ATM1	APCFA128GGDAD-W4BTM1

**Note:** Valid combinations are those products in mass production or will be in mass production. Consult your Apacer sales representative to confirm availability of valid combinations and to determine availability of new combinations.

## Revision History

Revision	Description	Date
1.0	Official release	11/29/2016
1.1	- Added product photo on Features page - Added CorePower technology illustration	12/14/2016
1.2	Revised CorePower technology illustration	12/15/2016
1.3	Revised General Description	12/26/2016
1.4	- Added product photo to the cover page - Updated functional block diagram at 2. Functional Block - Changed static/dynamic wear-leveling to Global Wear Leveling for Flash Management on Features page - Changed 5.3 Wear Leveling to 5.3 Global Wear Leveling at 5. Flash Management - Added a note to explain that SM22P-CFast is designed with a DRAM as a write cache at 5.6 Power Failure Management - Updated 9. Product Ordering Information due to FW change	1/26/2018
1.5	- Changed extended temperature to wide temperature - Changed SATA 6.0 Gbps to SATA 6 Gb/s in accordance with SATA naming guidelines - Updated operating/non-operating vibration spec at Table 4-3 Environmental Specifications - Updated MIL compliance from MIL-STD-810F to MIL-STD-810G at 4.5 Certification and Compliance - Capitalized every letter for commands at 6.1 Command Set and SMART subcommand at 6.2 S.M.A.R.T.	3/19/2020

## Global Presence

### Taiwan (Headquarters)

#### Apacer Technology Inc.

1F., No.32, Zhongcheng Rd., Tucheng Dist.,  
New Taipei City 236, Taiwan R.O.C.  
Tel: 886-2-2267-8000  
Fax: 886-2-2267-2261  
[amtsales@apacer.com](mailto:amtsales@apacer.com)

### Japan

#### Apacer Technology Corp.

6F, Daiyontamachi Bldg., 2-17-12, Shibaura, Minato-Ku,  
Tokyo, 108-0023, Japan  
Tel: 81-3-5419-2668  
Fax: 81-3-5419-0018  
[jpservices@apacer.com](mailto:jpservices@apacer.com)

### China

#### Apacer Electronic (Shanghai) Co., Ltd

Room D, 22/FL, No.2, Lane 600, JieyunPlaza,  
Tianshan RD, Shanghai, 200051, China  
Tel: 86-21-6228-9939  
Fax: 86-21-6228-9936  
[sales@apacer.com.cn](mailto:sales@apacer.com.cn)

### U.S.A.

#### Apacer Memory America, Inc.

46732 Lakeview Blvd., Fremont, CA 94538  
Tel: 1-408-518-8699  
Fax: 1-510-249-9551  
[sa@apacerus.com](mailto:sa@apacerus.com)

### Europe

#### Apacer Technology B.V.

Science Park Eindhoven 5051 5692 EB Son,  
The Netherlands  
Tel: 31-40-267-0000  
Fax: 31-40-290-0686  
[sales@apacer.nl](mailto:sales@apacer.nl)

### India

#### Apacer Technologies Pvt Ltd,

1874, South End C Cross, 9<sup>th</sup> Block Jayanagar,  
Bangalore-560069, India  
Tel: 91-80-4152-9061/62  
Fax: 91-80-4170-0215  
[sales\\_india@apacer.com](mailto:sales_india@apacer.com)