

***RoHS Compliant***

## **CFast 2.0**

***SM220-CFast 2.0 Product Specifications***

***April 14, 2017***

***Version 1.2***



**Apacer**  
*Access the best*

***Apacer Technology Inc.***

1F, No.32, Zhongcheng Rd., Tucheng Dist., New Taipei City, Taiwan, R.O.C

Tel: +886-2-2267-8000 Fax: +886-2-2267-2261

[www.apacer.com](http://www.apacer.com)

## Features:

- **Standard Serial ATA Interface**
  - SATA Revision 3.1 compliance
  - SATA 6.0 Gbps interface speed
  - Backward compatible with SATA 1.5 and 3.0 Gbps interfaces
  - ATA-compatible command set
- **Capacity**
  - 8, 16, 32, 64, 128 GB
- **Flash Management**
  - Built-in hardware ECC
  - Static/dynamic wear-leveling
  - Flash bad-block management
  - Flash Translation Layer: Page Mapping
  - S.M.A.R.T.
  - Power Failure Management
  - ATA Secure Erase
  - TRIM
- **Performance\***
  - Sustained read: Up to 265 MB/sec
  - Sustained write: Up to 180 MB/sec
  - Random read (4K): up to 47,000 IOPS
  - Random write (4K): up to 44,000 IOPS
- **NAND Flash Type: MLC**
- **MTBF: >1,000,000 hours**
- **Temperature Range**
  - Operating:
    - Standard: 0°C to 70°C
    - Extended: -40°C to 85°C
  - Storage: -40°C to 100°C
- **Power Consumption\***
  - Supply voltage: 3.3V
  - Active mode: 440 mA
  - Idle mode: 75 mA
- **Connector Type**
  - 7 + 17 pin female connector
- **Hardware Write-Protection Switch Support**
- **Device Sleep Mode (optional)**
- **RoHS Compliant**

\*Varies from capacities. The values presented in Power consumption and Performances are typical, and may vary depending on different settings and platforms.

---

## Table of Contents

<b>1. GENERAL DESCRIPTION</b> .....	<b>3</b>
<b>2. FUNCTIONAL BLOCK</b> .....	<b>3</b>
<b>3. PIN ASSIGNMENTS</b> .....	<b>4</b>
<b>4. PRODUCT SPECIFICATIONS</b> .....	<b>6</b>
4.1 CAPACITY .....	6
4.2 PERFORMANCE .....	6
4.3 ENVIRONMENTAL SPECIFICATIONS .....	7
4.4 MEAN TIME BETWEEN FAILURES (MTBF) .....	7
4.5 CERTIFICATION AND COMPLIANCE .....	7
<b>5. FLASH MANAGEMENT</b> .....	<b>8</b>
5.1 ERROR CORRECTION/DETECTION .....	8
5.2 BAD BLOCK MANAGEMENT .....	8
5.3 WEAR LEVELING .....	8
5.4 FLASH TRANSLATION LAYER – PAGE MAPPING .....	8
5.5 POWER FAILURE MANAGEMENT .....	8
5.6 ATA SECURE ERASE .....	9
5.7 TRIM .....	9
5.8 SATA POWER MANAGEMENT MODES .....	9
5.9 DEVSLP (DEVSLP OR DEVSLP) MODE .....	10
<b>6. SOFTWARE INTERFACE</b> .....	<b>11</b>
<b>7. ELECTRICAL SPECIFICATIONS</b> .....	<b>13</b>
7.1 OPERATING VOLTAGE .....	13
7.2 POWER CONSUMPTION .....	13
<b>8. PHYSICAL CHARACTERISTICS</b> .....	<b>14</b>
8.1 DIMENSIONS .....	14
<b>9. PRODUCT ORDERING INFORMATION</b> .....	<b>15</b>
9.1 PRODUCT CODE DESIGNATIONS .....	15
9.2 VALID COMBINATIONS .....	16

## 1. General Description

Apacer SM220-CFast 2.0 is the latest enhancement of conventional CFast form factor that delivers various technological advantages. This new flash memory card comes with SATA 6.0 Gbps interface for higher performance and consists of SATA-based 7-pin signal segment and 17-pin for power and control purposes. For data efficiency, the internal controlling unit of the SM220-CFast 2.0 is engineered with DRAM for enhanced random performance which achieves data transfer rates up to 265 MB/s in sequential access and 47,000 IOPS in 4KB random access. In addition, Apacer CFast cards come with S.M.A.R.T. for lifetime monitoring and customization support if write protection is required. Apacer SM220-CFast 2.0 guarantees reliability of applications in harsh environments by implementing intelligent Flash Management algorithms and Error Correction.

## 2. Functional Block

Apacer SM220-CFast 2.0 includes a single-chip SATA 6.0 Gbps and the flash media. The controller integrates the flash management unit to support multi-channel, multi-bank flash arrays. Figure 2-1 shows the functional block diagram.

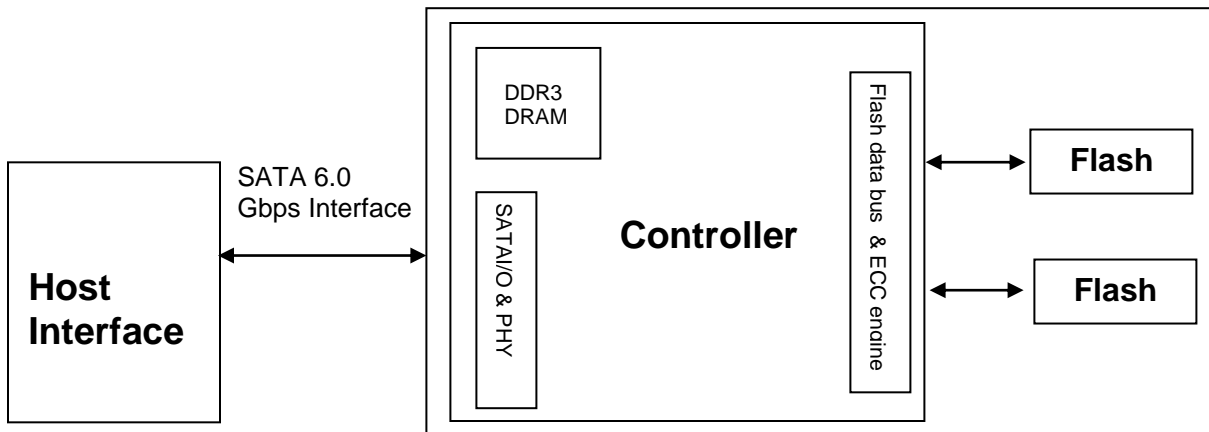
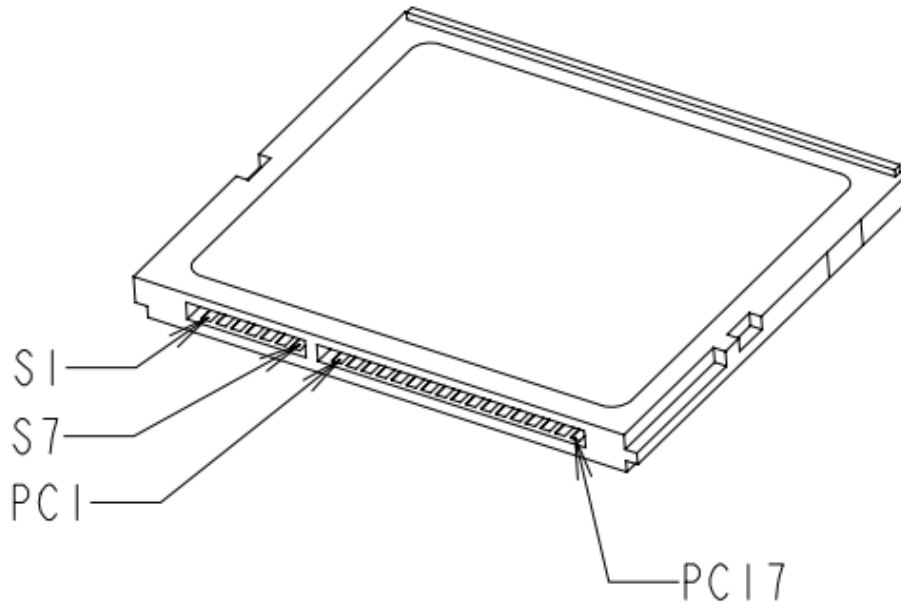

Figure 2-1 Block Diagram

### 3. Pin Assignments

Table 3-1 describes SM220-CFast 2.0 signal segment, and Table 3-2, its power segment.



**Figure 3-1** Pin Assignment

**Table 3-1** Signal Segment

Pin	Definition	Description
S1	GND	Ground
S2	A+	SATA Differential Signal Pair A
S3	A-	
S4	GND	Ground
S5	B-	SATA Differential Signal Pair B
S6	B+	
S7	GND	Ground

**Table 3-2 Power Segment**

Pin	Definition	Type	Description
PC1	CDI	Input	Card Detect In
PC2	PGND	Device GND	Device GND
PC3	DEVSLP*	DEVSLP card input	DEVSLP enable
PC4			Reserved
PC5			Reserved
PC6			Reserved
PC7	PGND	Device GND	Device GND
PC8	LED1	LED Output	Power indicator
PC9	LED2	LED Output	Access indicator
PC10			Reserved
PC11			Write Protect**
PC12	IFDet	GND	Card output, connect to PGND on card
PC13	PWR	3.3V	Device power (3.3V)
PC14	PWR	3.3V	Device power (3.3V)
PC15	PGND	Device GND	Device GND
PC16	PGND	Device GND	Device GND
PC17	CDO	Output	Card Detect Out

\*Optional

\*\*Enabled by adjusting the pin "PC11" from high to low active

Notes about Write Protect:

Apacer implements the Virtual Write scheme that allows write commands to go through the flash controller and data is temporarily stored, but no data has been actually written into the flash. Once the host resets or restarts the system, all the temporarily stored data will disappear and nowhere to be found in the drive. Since the Virtual Write scheme runs at device level, it requires no software or driver installation and is independent from the host OS.

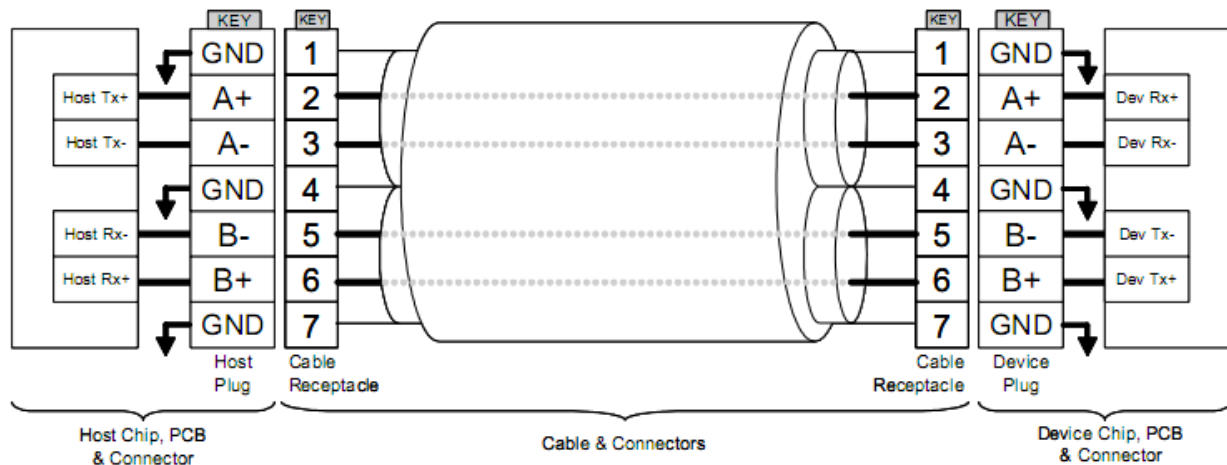

**Figure 3-2 SATA Cable / Connector Connection Diagram**

The connector on the left represents the Host with TX/RX differential pairs connected to a cable while the connector on the right shows the Device with TX/RX differential pairs also connected to the cable. Notice also the ground path connecting the shielding of the cable to the Cable Receptacle.

## 4. Product Specifications

### 4.1 Capacity

Capacity specifications of the SM220-CFast 2.0 are available as shown in Table 4-1. It lists the specific capacity and the default numbers of heads, sectors and cylinders for each product line.

**Table 4-1** Capacity Specifications

Capacity	Total bytes*	Cylinders	Heads	Sectors	Max LBA
8 GB	8,012,390,400	15,525	16	63	15,649,200
16 GB	16,013,942,784	16,383	16	63	31,277,232
32 GB	32,017,047,552	16,383	16	63	62,533,296
64 GB	64,023,257,088	16,383	16	63	125,045,424
128 GB	128,035,676,160	16,383	16	63	250,069,680

\*Display of total bytes varies from file systems.

\*\*Cylinders, heads or sectors are not applicable for these capacities. Only LBA addressing applies

LBA count addressed in the table above indicates total user storage capacity and will remain the same throughout the lifespan of the device. However, the total usable capacity of the SM220-CFast is most likely to be less than the total physical capacity because a small portion of the capacity is reserved for device maintenance usages.

### 4.2 Performance

Performance of SM220-CFast 2.0 product family is available as shown in Table 4-2.

**Table 4-2** Performance

Capacity Performance	8 GB	16 GB	32 GB	64 GB	128 GB
<b>Sustained Read (MB/s)</b>	120	220	220	280	265
<b>Sustained Write (MB/s)</b>	26	50	45	90	180
<b>Random Read IOPS (4K)</b>	15,000	26,000	25,000	46,000	47,000
<b>Random Write IOPS (4K)</b>	4,000	10,000	11,000	22,000	44,000

Note: Performance results are measured by CrystalDiskMark under Windows 7 and may vary from host system configurations.

---

### 4.3 Environmental Specifications

---

Environmental specifications of the SM220-CFast 2.0 follow the military standards, shown in Table 4-3.

**Table 4-3** Environmental Specifications

Environment	Specifications
Temperature	0°C to 70°C (Standard); -40°C to 85°C (Extended)
	-40°C to 100°C (Non-operating)
Vibration	Non-operating: Sine wave, 15(G), 10~2000(Hz), Operating: Random, 7.69(Grms), 20~2000(Hz)
Shock	Non-operating: Acceleration, 1,500 G, 0.5 ms Operating: Peak acceleration, 50 G, 11 ms

Note: This Environmental Specification table indicates the conditions for testing the device. Real world usages may affect the results.

---

### 4.4 Mean Time Between Failures (MTBF)

---

Mean Time Between Failures (MTBF) is predicted based on reliability data for the individual components in SM220-CFast 2.0. Serving as statistical reference, the prediction result for SM220-CFast is more than 1,000,000 hours.

Note: The MTBF is predicated and calculated based on “Telcordia Technologies Special Report, SR-332, Issue 2” method.

---

### 4.5 Certification and Compliance

---

SM220-CFast 2.0 complies with the following standards:

- CE
- FCC
- RoHS
- MIL-STD-810F

---

## **5. Flash Management**

### **5.1 Error Correction/Detection**

---

Apacer implements a hardware ECC scheme, based on the BCH algorithm. It can detect and correct up to 72 bits error in 1K bytes.

### **5.2 Bad Block Management**

---

Current production technology is unable to guarantee total reliability of NAND flash memory array. When a flash memory device leaves factory, it comes with a minimal number of initial bad blocks during production or out-of-factory as there is no currently known technology that produce flash chips free of bad blocks. In addition, bad blocks may develop during program/erase cycles. When host performs program/erase command on a block, bad block may appear in Status Register. Since bad blocks are inevitable, the solution is to keep them in control. Apacer flash devices are programmed with ECC, block mapping technique and S.M.A.R.T to reduce invalidity or error. Once bad blocks are detected, data in those blocks will be transferred to free blocks and error will be corrected by designated algorithms.

### **5.3 Wear Leveling**

---

Flash memory devices differ from Hard Disk Drives (HDDs) in terms of how blocks are utilized. For HDDs, when a change is made to stored data, like erase or update, the controller mechanism on HDDs will perform overwrites on blocks. Unlike HDDs, flash blocks cannot be overwritten and each P/E cycle wears down the lifespan of blocks gradually. Repeatedly program/erase cycles performed on the same memory cells will eventually cause some blocks to age faster than others. This would bring flash storages to their end of service term sooner. Wear leveling is an important mechanism that level out the wearing of blocks so that the wearing-down of blocks can be almost evenly distributed. This will increase the lifespan of SSDs. Commonly used wear leveling types are Static and Dynamic.

### **5.4 Flash Translation Layer – Page Mapping**

---

Page mapping is an advanced flash management technology whose essence lies in the ability to gather data, distribute the data into flash pages automatically, and then schedule the data to be evenly written. Page-level mapping uses one page as the unit of mapping. The most important characteristic is that each logical page can be mapped to any physical page on the flash memory device. This mapping algorithm allows different sizes of data to be written to a block as if the data is written to a data pool and it does not need to take extra operations to process a write command. Thus, page mapping is adopted to increase random access speed and improve SSD lifespan, reduce block erase frequency, and achieve optimized performance and lifespan.

### **5.5 Power Failure Management**

---

Power Failure Management plays a crucial role when experiencing unstable power supply. Power disruption may occur when users are storing data into the SSD. In this urgent situation, the controller would run multiple write-to-flash cycles to store the metadata for later block rebuilding. This urgent operation requires about several milliseconds to get it done. At the next power up, the firmware will perform a status tracking to retrieve the mapping table and resume previously programmed NAND blocks to check if there is any incompleteness of transmission.

---

## 5.6 ATA Secure Erase

---

ATA Secure Erase is an ATA disk purging command currently embedded in most of the storage drives. Defined in ATA specifications, (ATA) Secure Erase is part of Security Feature Set that allows storage drives to erase all user data areas. The erase process usually runs on the firmware level as most of the ATA-based storage media currently in the market are built-in with this command. ATA Secure Erase can securely wipe out the user data in the drive and protects it from malicious attack.

---

## 5.7 TRIM

---

TRIM is a SATA command that helps improve the read/write performance and efficiency of solid-state drives (SSD). The command enables the host operating system to inform SSD controller which blocks contain invalid data, mostly because of the erase commands from host. The invalid will be discarded permanently and the SSD will retain more space for itself.

---

## 5.8 SATA Power Management Modes

---

By complying with SATA 6.0 Gb/s specifications, the SSD supports the following SATA power saving modes:

- ACTIVE: PHY ready, full power, Tx & Rx operational
- PARTIAL: Reduces power, resumes in under 10  $\mu$ s (microseconds)
- SLUMBER: Reduces power, resumes in under 10 ms (milliseconds)
- HIPM: Host-Initiated Power Management
- DIPM: Device-Initiated Power Management
- AUTO-SLUMBER: Automatic transition from partial to slumber.
- Device Sleep (DevSleep or DEVSLP): PHY powered down; power consumption  $\leq$  5 mW; host assertion time  $\leq$  10 ms; exit timeout from this state  $\leq$  20 ms (unless specified otherwise in SATA Identify Device Log).

Note:

1. The behaviors of power management features would depend on host/device settings.
2. Device Sleep mode is optional depending on product ordering selections.

## 5.9 DEVSLP (DevSleep or DEVSLP) Mode

Device Sleep is a feature that allows SATA devices to enter a low power mode by designating pin 44 as DEVSLP signal with an aim to reducing power consumption.

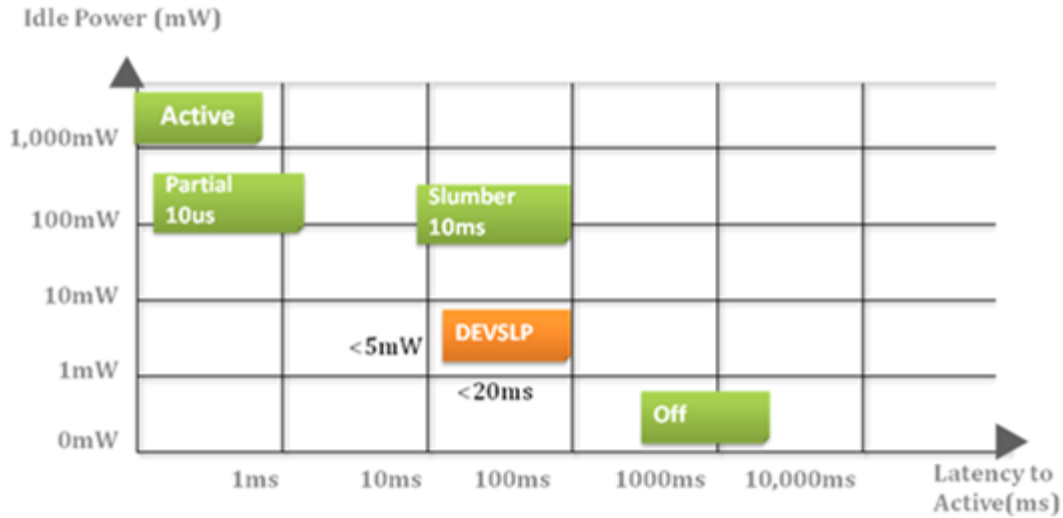

## 6. Software Interface

### 6.1 Command Set

**Table 6-1** Command Set

Code	Command	Code	Command
E5h	Check Power Mode	F6h	Security Disable Password
90h	Execute Diagnostics	F3h	Security Erase Prepare
E7h	Flush Cache	F4h	Security Erase Unit
ECh	Identify Device	F5h	Security Freeze Lock
E3h	Idle	F1h	Security Set Password
E1h	Idle Immediate	F2h	Security Unlock
91h	Initialize Device Parameters	7Xh	Seek
C8h	Read DMA	EFh	Set Features
25h	Read DMA EXT	C6h	Set Multiple Mode
60h	Read FPDMA Queued	E6h	Sleep
47h	Read Log DMA EXT	B0h	S.M.A.R.T.
2Fh	Read Log EXT	E2h	Standby
C4h	Read Multiple	E0h	Standby Immediate
20 or 21h	Read Sector(s)	CAh	Write DMA
40 or 41h	Read Verify Sector(s)	35h	Write DMA EXT
10h	Recalibrate	61h	Write FPDMA Queued
57h	Write Log DMA EXT	3Fh	Write Log EXT
C5h	Write Multiple	30h or 31h	Write Sector(s)

### 6.2 S.M.A.R.T.

S.M.A.R.T. is an abbreviation for Self-Monitoring, Analysis and Reporting Technology, a self-monitoring system that provides indicators of drive health as well as potential disk problems. It serves as a warning for users from unscheduled downtime by monitoring and displaying critical drive information. Ideally, this should allow taking proactive actions to prevent drive failure and make use of S.M.A.R.T. information for future product development reference.

Apacer devices use the standard SMART command B0h to read data out from the drive to activate our S.M.A.R.T. feature that complies with the ATA/ATAPI specifications. S.M.A.R.T. Attribute IDs shall include initial bad block count, total later bad block count, maximum erase count, average erase count, power on hours and power cycle. When the S.M.A.R.T. Utility running on the host, it analyzes and reports the disk status to the host before the device reaches in critical condition.

Note: Attribute IDs may vary from product models due to various solution design and supporting capabilities.

# SM220-CFast 2.0

## APCFxxxGGDWN-X4XTM1

Apacer memory products come with S.M.A.R.T. commands and subcommands for users to obtain information of drive status and to predict potential drive failures. Users can take advantage of the following commands/subcommands to monitor the health of the drive.

Code	SMART Subcommand
D0h	READ DATA
D1h	READ ATTRIBUTE THRESHOLDS
D2h	Enable/Disable Attribute Autosave
D4h	Execute Off-line Immediate
D5h	Read Log (optional)
D6h	Write Log (optional)
D8h	Enable Operations
D9h	Disable operations
DAh	Return Status

### General SMART attribute structure

Byte	Description
0	ID (Hex)
1 – 2	Status flag
3	Value
4	Worst
5*-11	Raw Data

\*Byte 5: LSB

### SMART attribute ID list

ID (Hex)	Attribute Name
9 (0x09)	Power-on hours
12 (0x0C)	Power cycle count
163 (0xA3)	Max. erase count
164 (0xA4)	Avg. erase count
166 (0xA6)	Total later bad block count
167 (0xA7)	SSD Protect Mode (vendor specific)
168 (0xA8)	SATA PHY Error Count
175 (0xAF)	Bad Cluster Table Count
192 (0xC0)	Unexpected Power Loss Count
194 (0xC2)	Temperature
241 (0xF1)	Total sectors of write

## 7. Electrical Specifications

### 7.1 Operating Voltage

Table 7-1 lists operating voltage of SM220-CFast 2.0.

**Table 7-1** Operating Voltage

Parameter	Symbol	Min	Type	Max	Units
Power Supply	Vcc	3.135	3.3	3.465	V

### 7.2 Power Consumption

Table 7-2 lists power consumption of SM220-CFast 2.0.

**Table 7-2** Power Consumption (typical)

Capacity Mode	8 GB	16 GB	32 GB	64 GB	128 GB
<b>Active (mA)</b>	195	225	230	295	440
<b>Idle (mA)</b>	75	75	75	75	75

Note: Power consumption may vary from flash configurations and/or platform settings.

## 8. Physical Characteristics

### 8.1 Dimensions

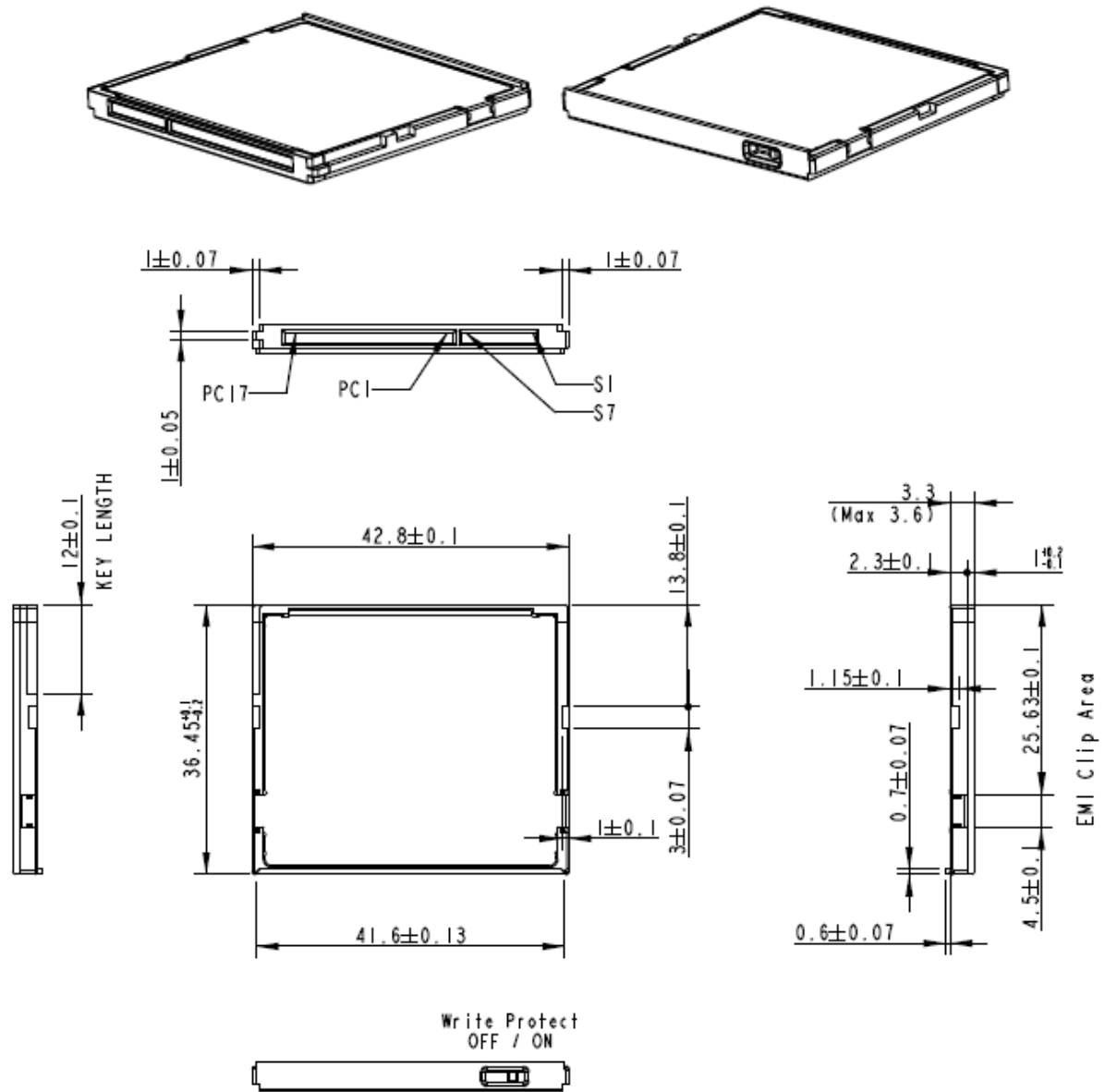
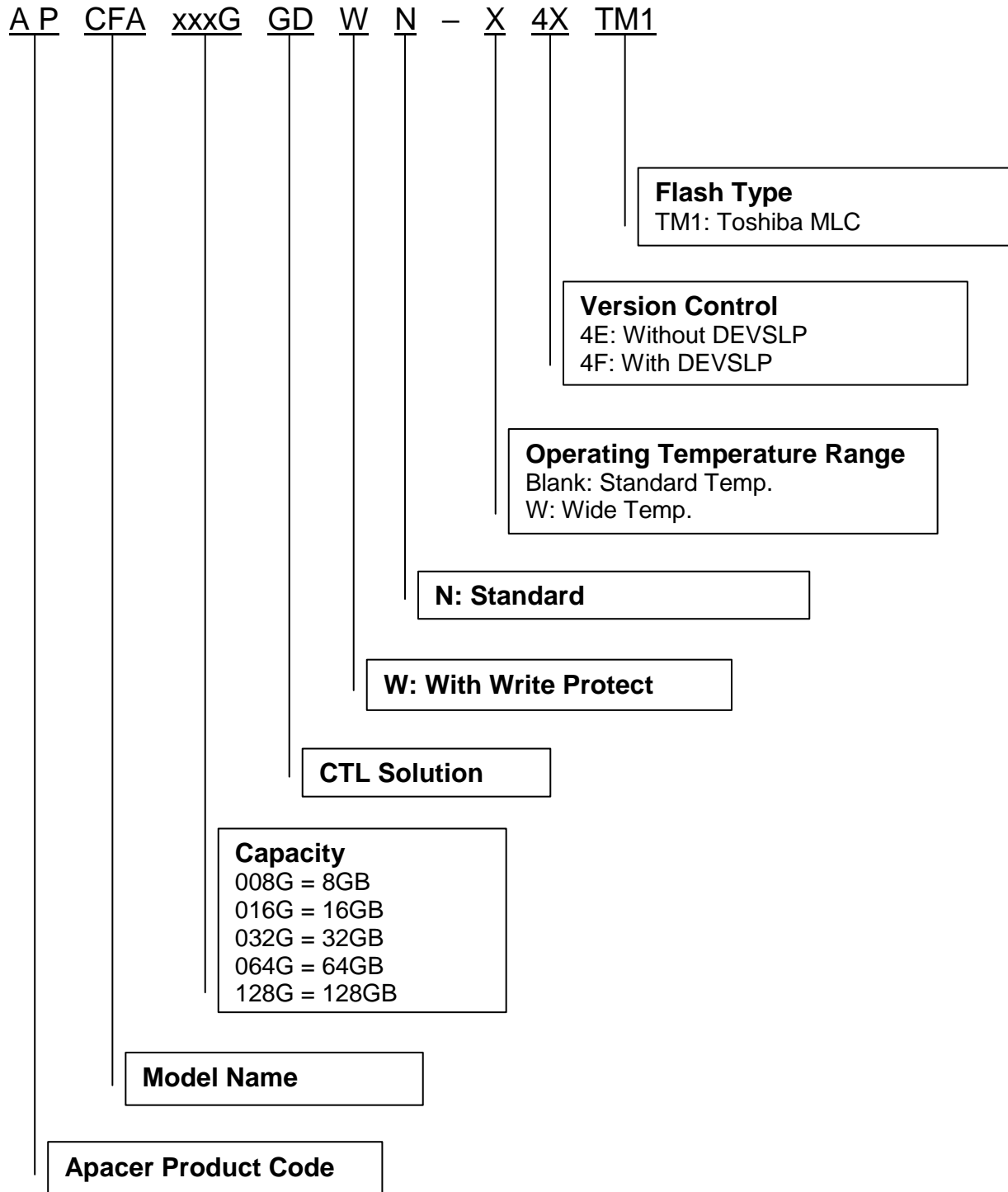

Figure 8-1 Physical Dimensions

## 9. Product Ordering Information

### 9.1 Product Code Designations



# SM220-CFast 2.0

## APCFAxxxGGDWN-X4XTM1



### 9.2 Valid Combinations

#### 9.2.1 Standard Temperature (0°C to 70°C)

Capacity	Without DEVSLP	With DEVSLP
8GB	APCFA008GGDWN-4ETM1	APCFA008GGDWN-4FTM1
16GB	APCFA016GGDWN-4ETM1	APCFA016GGDWN-4FTM1
32GB	APCFA032GGDWN-4ETM1	APCFA032GGDWN-4FTM1
64GB	APCFA064GGDWN-4ETM1	APCFA064GGDWN-4FTM1
128GB	APCFA128GGDWN-4ETM1	APCFA128GGDWN-4FTM1

#### 9.2.2 Wide Temperature (-40°C to 85°C)

Capacity	Without DEVSLP	With DEVSLP
8GB	APCFA008GGDWN-W4ETM1	APCFA008GGDWN-W4FTM1
16GB	APCFA016GGDWN-W4ETM1	APCFA016GGDWN-W4FTM1
32GB	APCFA032GGDWN-W4ETM1	APCFA032GGDWN-W4FTM1
64GB	APCFA064GGDWN-W4ETM1	APCFA064GGDWN-W4FTM1
128GB	APCFA128GGDWN-W4ETM1	APCFA128GGDWN-W4FTM1

**Note:** Valid combinations are those products in mass production or will be in mass production. Consult your Apacer sales representative to confirm availability of valid combinations and to determine availability of new combinations.

---

## Revision History

Revision	Date	Description	Remark
1.0	2/7/2017	Official release	
1.1	3/29/2017	- Updated functional block diagram - Removed the note from 5.5 Power Failure Management - Updated the description of 5.4 Flash Translation Layer – Page Mapping	
1.2	4/14/2017	Updated product ordering information	

---

## Global Presence

<b>Taiwan (Headquarters)</b>	<b>Apacer Technology Inc.</b> Apacer Technology Inc. 1F., No.32, Zhongcheng Rd., Tucheng Dist., New Taipei City 236, Taiwan R.O.C. Tel: 886-2-2267-8000 Fax: 886-2-2267-2261 <a href="mailto:amtsales@apacer.com">amtsales@apacer.com</a>
<b>U.S.A.</b>	<b>Apacer Memory America, Inc.</b> 46732 Lakeview Blvd., Fremont, CA 94538 Tel: 1-408-518-8699 Fax: 1-510-249-9551 <a href="mailto:sa@apacerus.com">sa@apacerus.com</a>
<b>Japan</b>	<b>Apacer Technology Corp.</b> 5F, Matsura Bldg., Shiba, Minato-Ku Tokyo, 105-0014, Japan Tel: 81-3-5419-2668 Fax: 81-3-5419-0018 <a href="mailto:jpservices@apacer.com">jpservices@apacer.com</a>
<b>Europe</b>	<b>Apacer Technology B.V.</b> Science Park Eindhoven 5051 5692 EB Son, The Netherlands Tel: 31-40-267-0000 Fax: 31-40-290-0686 <a href="mailto:sales@apacer.nl">sales@apacer.nl</a>
<b>China</b>	<b>Apacer Electronic (Shanghai) Co., Ltd</b> Room D, 22/FL, No.2, Lane 600, JieyunPlaza, Tianshan RD, Shanghai, 200051, China Tel: 86-21-6228-9939 Fax: 86-21-6228-9936 <a href="mailto:sales@apacer.com.cn">sales@apacer.com.cn</a>
<b>India</b>	<b>Apacer Technologies Pvt Ltd,</b> Unit No.201, "Brigade Corner", 7 <sup>th</sup> Block Jayanagar, Yediyur Circle, Bangalore – 560082, India Tel: 91-80-4152-9061 Fax: 91-80-4170-0215 <a href="mailto:sales_india@apacer.com">sales_india@apacer.com</a>